

# **BAXI**

## User's Operating Instructions



### **Baxi Combi Instant 80e & 105e**

Gas Fired Wall Mounted Combination  
Boiler

Please keep these instructions safe.  
Should you move house, please hand  
them over to the next occupier.

## Natural Gas

---

**Baxi Combi Instant 80e**  
G.C.N° 47 075 13

**Baxi Combi Instant 105e**  
G.C.N° 47 075 09

Baxi is one of the leading manufacturers of domestic heating products in the UK.

Our first priority is to give a high quality service to our customers. Quality is designed into every Baxi product - products which fulfil the demands and needs of customers, offering choice, efficiency and reliability.

To keep ahead of changing trends, we have made a commitment to develop new ideas using the latest technology - with the aim of continuing to make the products that customers want to buy.

Everyone who works at Baxi has a commitment to quality because we know that satisfied customers mean continued success.

We hope you get a satisfactory service from Baxi. If not, please let us know.

The boiler meets the requirements of Statutory Instrument "The Boiler (Efficiency) Regulations 1993 N° 3083" and is deemed to meet the requirements of Directive 92/42/EEC on the energy efficiency requirements for new hot water boilers fired with liquid or gaseous fuels:-

Type test for purpose of Regulation 5 certified by:  
Notified Body 0051.

Product/Production certified by:  
Notified Body 0051.

For GB/IE only.



Baxi is a BS-EN ISO 9001  
Accredited Company

## Legislation

### IMPORTANT - Installation, Commissioning, Service & Repair

This appliance must be installed in accordance with the manufacturer's instructions and the regulations in force. Read the instructions fully before installing or using the appliance.

In GB, this must be carried out by a competent person as stated in the Gas Safety (Installation & Use) Regulations.

Definition of competence: A person who works for a CORGI registered company and holding current certificates in the relevant ACS modules, or valid ACoP equivalents, is deemed competent.

In IE, this must be carried out by a competent person as stated in I.S. 813 "Domestic Gas Installations".

This product should be lifted and handled by two people. Stooping should be avoided and protective equipment worn where necessary. Carrying & lifting equipment should be used as required.

The addition of anything that may interfere with the normal operation of the appliance without express written permission from the manufacturer or his agent could invalidate the appliance warranty. In GB this could also infringe the Gas Safety (Installation and Use) Regulations.

**Warning** - Check the information on the data plate is compatible with local supply conditions.

### "Benchmark"

#### Installation, Commissioning and Service Record Log Book

Please ensure that your installer has completed the Installation and Commissioning sections of the Log Book and hands the Log Book over. The details of the Log Book will be required in the event of any warranty work. Keep the Log Book in a safe place and ensure that the relevant sections are completed at each subsequent regular service visit.

All CORGI registered installers carry a CORGI identification card and have a registration number. Both should be recorded in your boiler Log Book. You can check your installer is registered by telephoning +44 (0)1256 372300 or writing to:-

1 Elmwood,  
Chineham Business Park,  
Crockford Lane,  
Basingstoke. RG24 8WG

**Baxi declare that no substances harmful to health are contained in the appliance or used during appliance manufacture.**

**The appliance is suitable only for installation in GB and IE and should be installed in accordance with the rules in force, and only used in a suitably ventilated location.**

In GB, the installation must be carried out by a CORGI Registered Installer. It must be carried out in accordance with the relevant requirements of the:

- Gas Safety (Installation & Use) Regulations.
- The appropriate Building Regulations either The Building Regulations, The Building Regulations (Scotland), Building Regulations (Northern Ireland).
- The Water Fittings Regulations or Water Byelaws in Scotland.
- The Current I.E.E. Wiring Regulations.

Where no specific instructions are given, reference should be made to the relevant British Standard Code of Practice.

In IE, the installation must be carried out by a competent Person and installed in accordance with the current edition of I.S. 813 'Domestic Gas Installations', the current Building Regulations and reference should be made to the current ETCI rules for electrical installation.

**All systems must be thoroughly flushed and treated with inhibitor.**

**Codes of Practice**, most recent version should be used

**In GB the following Codes of Practice apply:**

Standard	Scope
BS 6891	Gas Installation.
BS 5546	Installation of hot water supplies for domestic purposes.
BS 5449	Forced circulation hot water systems.
BS 6798	Installation of gas fired hot water boilers.
BS 5440 Part 1	Flues.
BS 5440 Part 2	Ventilation.
BS 7074	Expansion vessels and ancillary equipment for sealed water systems.
BS 7593	Treatment of water in domestic hot water central heating systems.

**In IE the following Codes of Practice apply:**

Standard	Scope
I.S. 813	Domestic Gas Installations.
The following BS standards give valuable additional information;	
BS 5546	Installation of hot water supplies for domestic purposes.
BS 5449	Forced circulation hot water systems.
BS 7074	Expansion vessels and ancillary equipment for sealed water systems.
BS 7593	Treatment of water in domestic hot water central heating systems.

## 1.0 Warnings

### 1.1 In an Emergency

If a water or gas leak occurs or is suspected, the boiler can be isolated at the inlet valves as follows;

1. Turn off the electrical supply and turn the selector switch on the fascia box to the OFF position.
2. Using a suitable open ended spanner or screwdriver turn the square on the gas tap to the left to isolate the gas supply at the boiler (Fig. 1).
3. The isolating valves are positioned under the boiler and can be closed by turning their taps to the right towards the wall (Fig. 2).
4. Call your installer or Service Engineer as soon as possible.

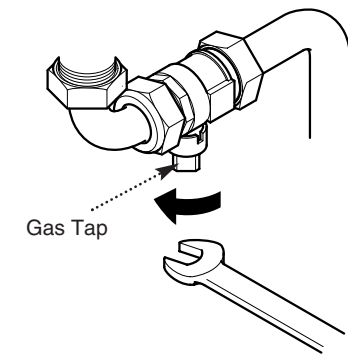

Fig. 1

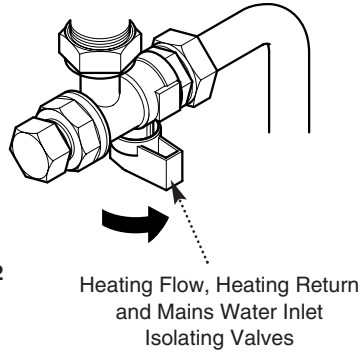

Fig. 2

### 1.2 In case of gas leaks

1. If a gas leak is found or suspected, turn off the gas supply at the meter immediately and at the isolating valve on the boiler if possible. Contact your Gas Supplier immediately.

### 1.3 Servicing your Appliance

1. For reasons of safety and economy your appliance should be serviced annually. Servicing must be performed by a competent person. Your installer or Service Engineer will be able to advise you.
2. Any purpose provided ventilation should be checked periodically to ensure that it is free from obstruction.

### 1.4 Electricity Supply

1. **THIS APPLIANCE MUST BE EARTHED.**
2. A standard 230V ~ 50Hz supply is required. The appliance must be protected by a 3 amp fuse.

**Never Hang Flammable Items Over The Appliance**

## 2.0 Introduction

### 2.1 Introduction

1. Your Baxi Combi Instant 80e or 105e is a gas fired, room sealed, powered flue combination boiler, providing central heating for your home and mains fed domestic hot water to taps and shower. It is fully automatic and does not have a pilot light.

2. Priority is given to the hot water mode - when a hot water tap is turned on the supply of heat to the central heating circuit is interrupted.

### 2.2 Instant Domestic Hot Water

1. The boiler expansion vessel incorporates a small volume of stored primary hot water.

2. When the boiler has been off and there is then a demand for domestic hot water the stored primary hot water ensures that domestic hot water is supplied instantly at temperature.

3. The stored hot water is part of the primary circuit. This is not supplied as domestic hot water, which is fresh mains water heated by a heat exchanger within the boiler.

4. The stored primary hot water temperature is maintained whilst the boiler is in operation. During a period when there is no demand for heating or hot water the temperature of the stored primary hot water will eventually fall. The boiler will operate occasionally in order to maintain the temperature. This is indicated by the domestic hot water mode neon flashing (item 13 of Fig. 3).

### 2.3 Facia Panel

1. The facia panel is behind the hinged lower door. As well as the on/off/reset selector switch, central heating temperature control knob, pre-heat control and pressure gauge, the facia incorporates ten neon indicator lights.

2. Neons 12 to 15 indicate the operational status of the boiler. Neons 6 to 11 have a dual function, indicating the temperature of the central heating water when constantly illuminated. If a fault develops the appropriate neon will begin to flash. Refer to Sections 3.3 to 3.7.

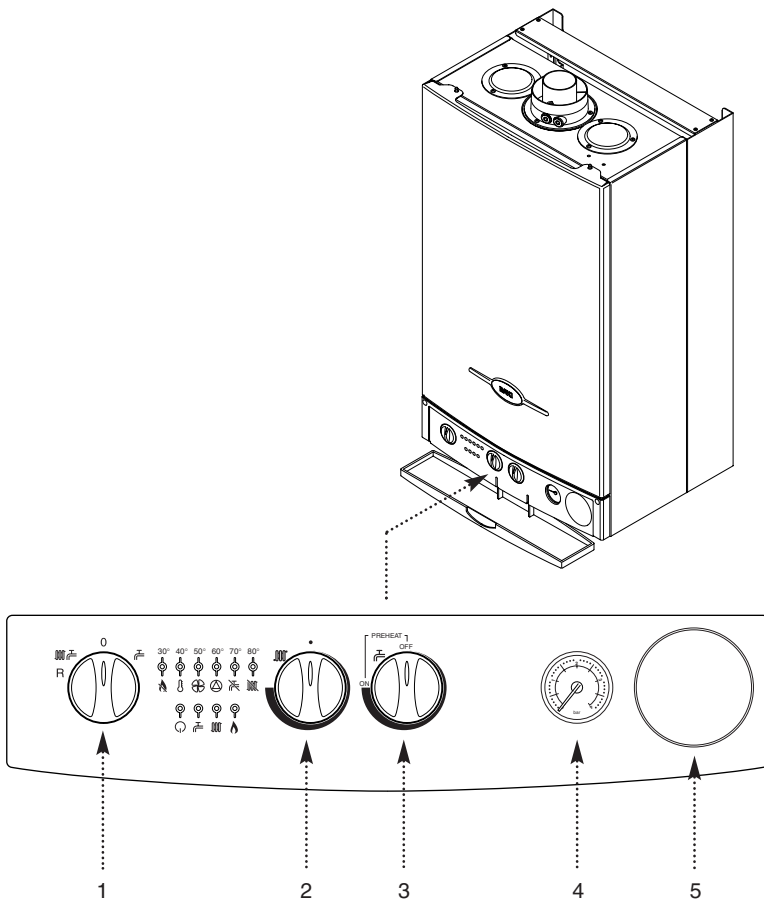
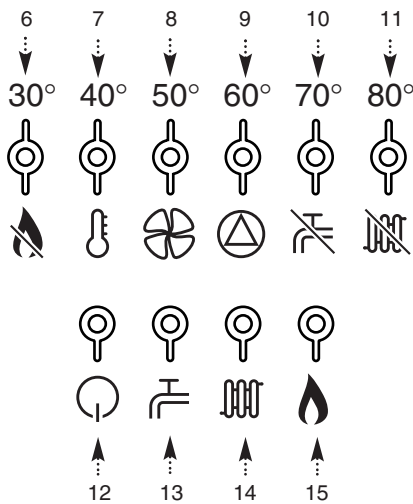

Fig. 3



#### KEY TO FACIA PANEL (Fig. 3)

1. On/Off/Reset Selector Switch
2. Central Heating Temperature Control
3. Pre-Heat Control
4. Central Heating System Pressure Gauge
5. Optional Integral Timer Position

#### Neon Indicators

6. Flame Failure
7. Safety Thermostat Activated
8. Fault on Fan or Flue
9. Fault on Pump or Low System Pressure
10. Fault on Hot Water Sensor
11. Fault on Central Heating Sensor
12. Power On
13. Domestic Hot Water Mode
14. Central Heating Mode
15. Burner On

When neons 6 to 11 are constantly illuminated, they indicate the temperature of the central heating water.

## 3.0 Operating the Boiler

### 3.1 Operating the Boiler

1. Ensure that the electricity and gas supplies are turned on. Check that the central heating pressure is between 0.5 and 1.0 bar (Fig. 4).

2. Turn the On/Off/Reset selector switch either anti-clockwise from the off position (Fig. 6) to both central heating and domestic hot water or clockwise to domestic hot water only.

3. In either position the green power on indicator (⊙) will illuminate (Fig. 5).

4. **Position (i)** In this position the central heating will operate according to demand or provide domestic hot water when a tap or shower is turned on (Fig. 7). Priority is given to domestic hot water. The central heating/hot water neon (⊞) will illuminate (Fig. 5). Neons 6 to 11 will illuminate as the temperature rises.

5. **Position (ii)** In this position hot water will be provided when a tap or shower is turned on (Fig. 8). The hot water neon (⊞) will illuminate (Fig. 5).

6. The boiler will light automatically on demand.

7. The orange burner on neon (⊞) will illuminate when the boiler is operating and the main burner is on (Fig. 5).

**IMPORTANT:** When the selector switch is in the '0' (Off) position the electrical supply to the boiler is isolated. The boiler will not operate and the integral timer (if fitted) will require resetting once the selector switch is set to either Position (i) or Position (ii).

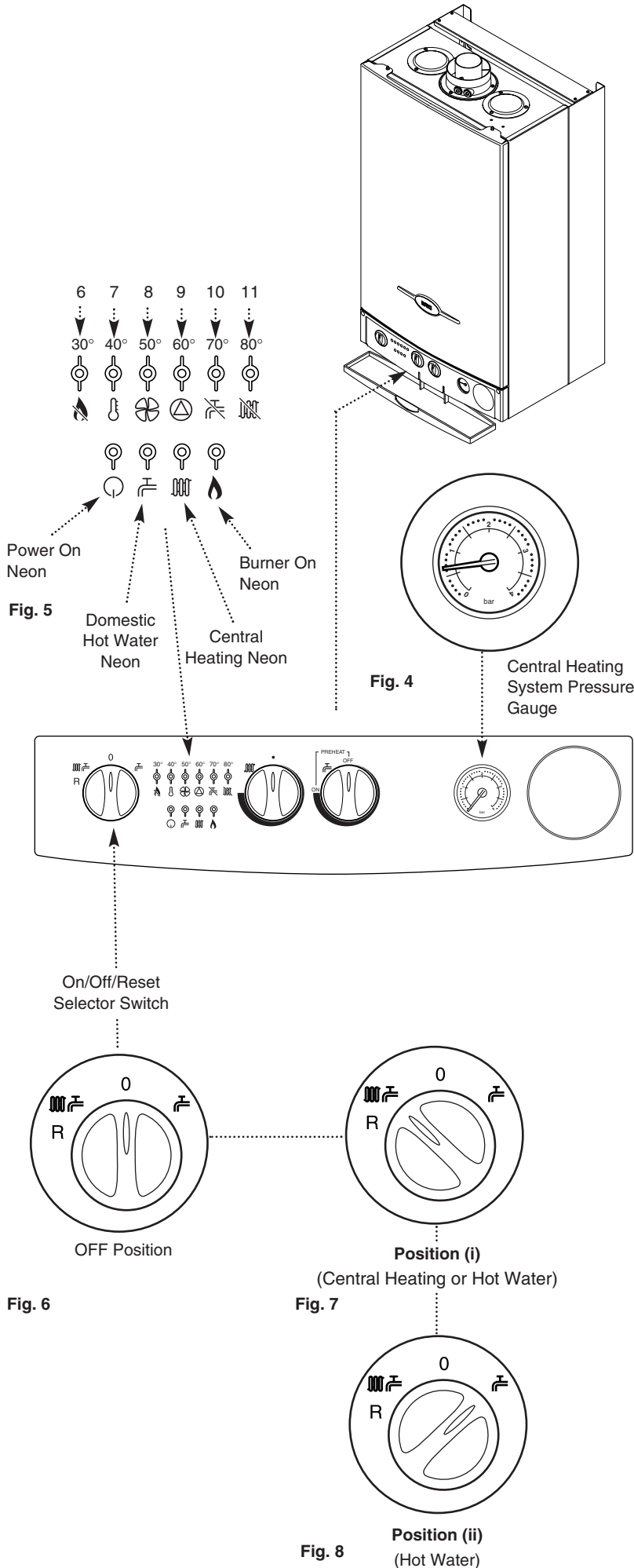

## 3.0 Operating the Boiler

### 3.2 Temperature Control

1. **Central Heating:** The central heating hot water flow temperature can be adjusted between 30° C ( $\pm 5^\circ$  C) minimum and 85° C ( $\pm 5^\circ$  C) maximum.

2. Turn the control knob clockwise to increase the temperature (Fig. 9).

3. In normal winter usage we recommend that the central heating temperature be set at maximum.

4. **Domestic Hot Water Pre-Heat:** To enjoy optimum performance of the boiler the pre-heat control should be set fully clockwise to the ON position (Fig. 10). When there is a demand for hot water it will be supplied at approximately 65° C instantaneously.

5. Turning the control 15° clockwise from the OFF position will activate the pre-heat feature. Hot water will be supplied at approximately 35° C instantaneously.

6. To increase the temperature turn the control further clockwise. For example, when set 90° clockwise the boiler will supply hot water at approximately 44° C instantaneously. At a position 180° from clockwise (i.e. straight down) the hot water will be supplied at 52° C instantaneously.

7. When the control is set anywhere between 15° clockwise from the OFF position and the ON position, the pre-heat feature will operate.

8. With the control in the OFF position (Fig. 11) the pre-heat feature will not operate. Hot water will be supplied at approximately 50° C.

9. The pre-heat feature will function with the selector switch in either operating position. This is indicated by the domestic hot water mode neon flashing (Fig. 12).

10. The flow rate can be reduced down to as low as 2.5 litre/min. The boiler will still recognise the need to heat the water.

### 3.3 Flame Failure Reset

1. The red flame failure neon (  ) will illuminate in the event of the burner failing to light, or when incomplete lighting of the burner occurs (Fig. 12).

2. Turn the selector switch fully anti-clockwise against the spring pressure to the reset position (R) and release (Fig. 13). Set the selector to the required position to light the boiler.

3. If the flame failure light illuminates repeatedly a fault is indicated. Your installer or Service Engineer should be called as soon as possible.

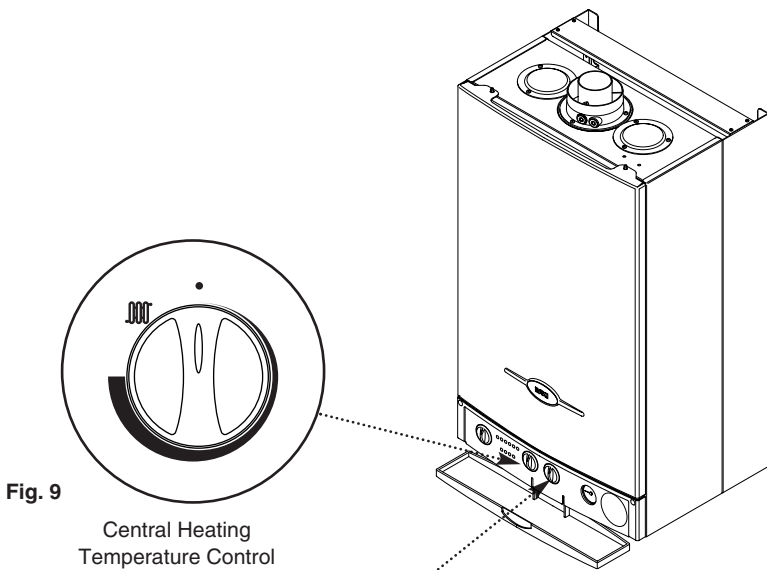

Fig. 9  
Central Heating  
Temperature Control

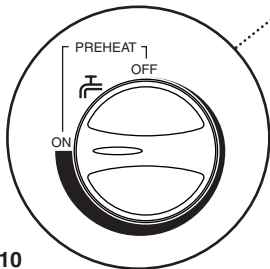

Fig. 10  
Domestic Hot Water  
Pre-Heat Control  
ON Position

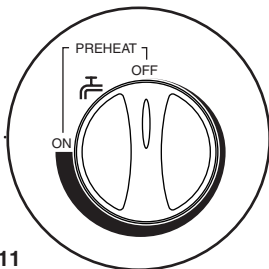

Fig. 11  
Domestic Hot Water  
Pre-Heat Control  
OFF Position

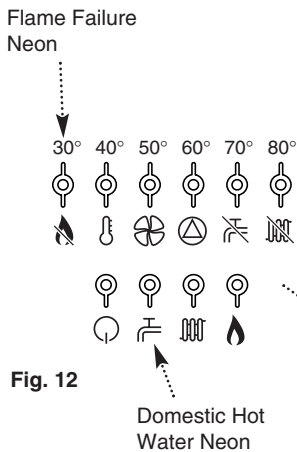
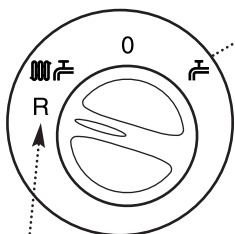

Fig. 12  
Domestic Hot  
Water Neon



Reset Position

Fig. 13



## 3.0 Operating the Boiler

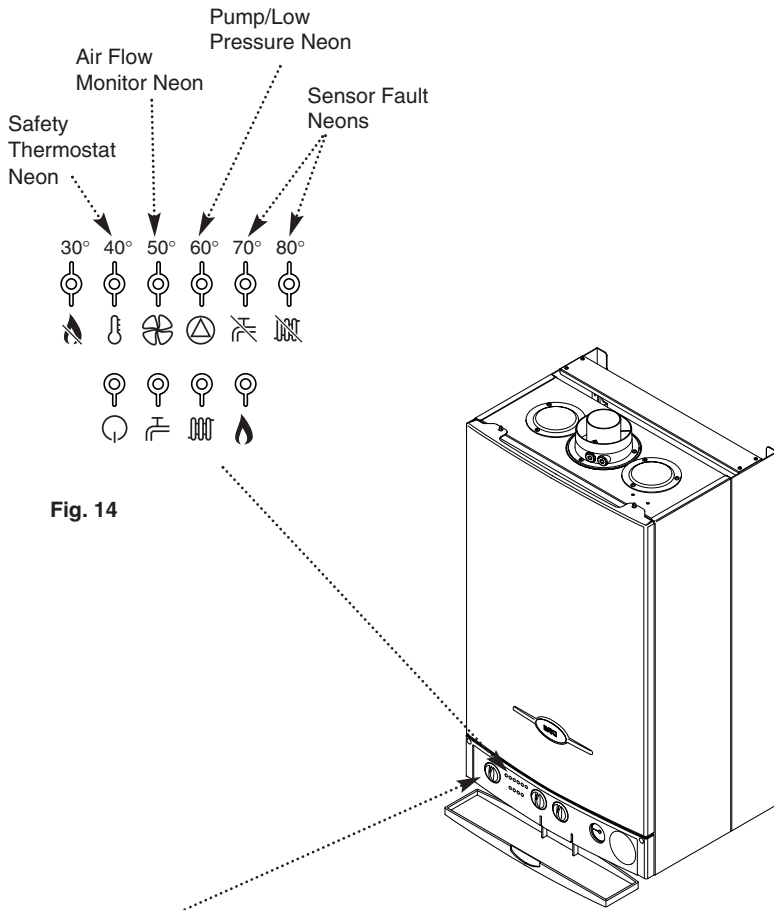
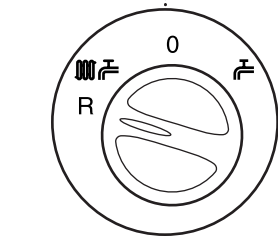

Fig. 14



Reset Position

Fig. 15

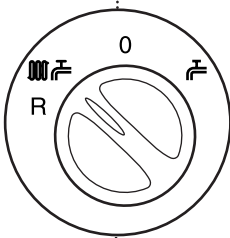

Fig. 16

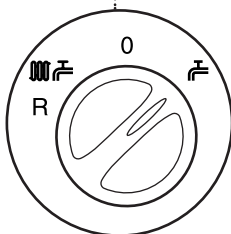



Fig. 17

### 3.4 Safety Thermostat

1. Your Baxi Combi Instant 80e or 105e is fitted with an additional safety device, which shuts down the boiler in the event of the system or the boiler overheating. The safety thermostat neon (  ) will light in this instance (Fig. 14).

2. **To reset:** Turn the selector fully anti-clockwise against the spring pressure to the reset position (R) and release (Fig. 15). Set the selector to the required position to light the boiler.

3. If the safety thermostat operates repeatedly, causing boiler shutdown, a fault is indicated. Your installer or Service Engineer should be contacted as soon as possible.

### 3.5 Air Flow Monitor

1. The boiler is fitted with an air pressure sensing device. This monitors the flue system.



2. If the neon illuminates (  ) it indicates that the flue or flue terminal is blocked or obstructed in some way, or that there is an internal fault. If there is no external blockage of the flue terminal that can be easily removed contact your installer or Service Engineer (Fig. 14).

### 3.6 Pump Fault or Low Pressure

1. The neon (  ) will illuminate if the circulating pump is faulty or the system pressure drops below the minimum requirement (Fig. 14).

2. Check the pressure gauge as described in Section 3.9. If the pressure is in the normal range, a pump fault is indicated. Contact your installer or Service Engineer to determine the nature of the fault.

### 3.7 Sensor Fault

1. When the (  ) or (  ) neon is illuminated a fault on the hot water or central heating temperature sensor is indicated (Fig. 14). Contact your installer or Service Engineer.

### 3.8 Pump Protection

1. With the selector switch in either Position (i) or Position (ii) (Figs. 16 & 17) the pump will automatically operate for 1 minute in every 24 hours to prevent sticking.



## 3.0 Operating the Boiler

### 3.9 Central Heating System Pressure

1. The water pressure in the central heating system is indicated by the pressure gauge.
2. With the system cold and the boiler not operating the pressure should be between 0.5 and 1.0 bar. During operation the pressure should not exceed 2.5 bar, and will normally be between 1.0 and 2.0 (Figs. 18 & 19).
3. A pressure of 3 or greater indicates a fault. The safety pressure relief valve will operate, at a pressure of 3 (Fig. 20). **It is important that your installer or Service Engineer is contacted as soon as possible.**
4. The MINIMUM pressure for correct operation is 0.5. If the pressure falls below 0.5, this may indicate a leak on the central heating system (Fig. 21).
5. The system must be re-pressurised by your installer or Service Engineer.

### 3.10 To Shut Off the Boiler

1. **For short periods:** Turn the selector switch to the OFF position (Fig. 22).
2. **For long periods:** Turn off the selector switch (Fig. 22), electricity and gas supplies.

If your home is to be left unoccupied for long periods during cold weather the boiler and whole system should be drained unless there is additional frost protection.

3. Your installer will advise you about frost protection and draining the system.

**IMPORTANT:** When the selector switch is in the '0' (Off) position the electrical supply to the boiler is isolated. The boiler will not operate and the integral timer (if fitted) will require resetting once the selector switch is set to either Position (i) or Position (ii).

### 3.11 Frost Protection Mode

1. The frost protection feature will operate when the selector switch is in the central heating and domestic hot water mode. The gas and electrical supplies to the boiler must be on and the system pressure must be within the range described in Section 3.9.
2. If the system temperature falls below 5°C, then the boiler will fire until the water temperature has been raised.
3. Further frost protection can be incorporated by using a frost thermostat to protect the whole system.

Pressure Gauge

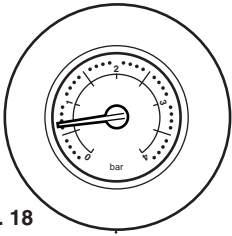

Fig. 18  
Normal Pressure (when cold)

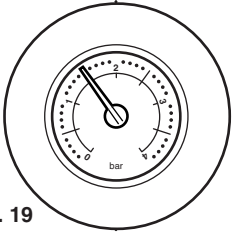

Fig. 19  
Normal Pressure (operating)

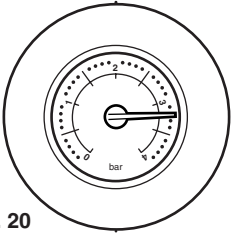

Fig. 20  
Fault

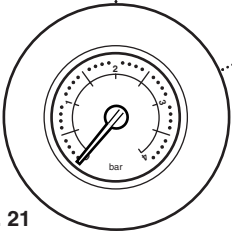
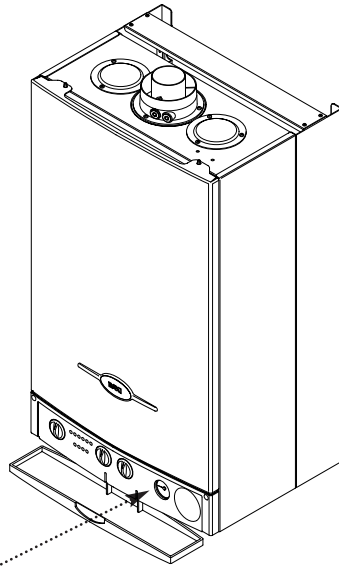

Fig. 21  
Below Minimum



ON/OFF  
Selector Switch

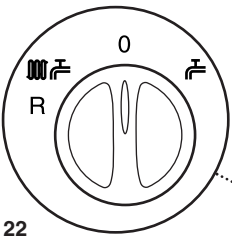
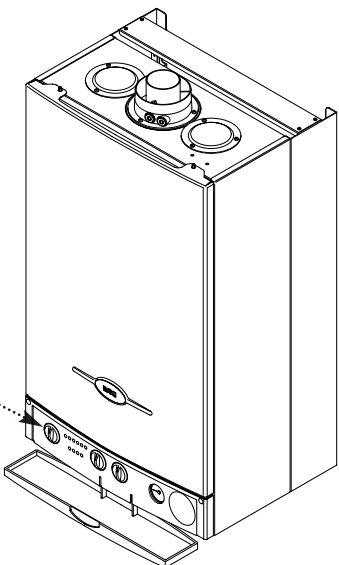

Fig. 22  
OFF Position



## 4.0 Clearances and Check List

### 4.1 Clearances around the Boiler

(Figs. 23 & 24)

1. The minimum clear spaces needed around the boiler measured from the casing are as follows:

Top	-	200mm	
Bottom	-	200mm	
Both sides	-	5mm	
Front	-	5mm	(In Operation)
	-	450mm	(For Servicing)

2. **These areas must not be obstructed in any way. Blocking the clearance spaces may result in the boiler overheating and damage may occur.**

3. The gas burning compartment of your boiler is completely sealed from the room in which it is fitted. Products from the combustion of gas are vented to the outside through the flue terminal which must be kept free from obstruction as this would interfere with the correct operation of the boiler.

4. The boiler may be installed in a cupboard if these minimum clearances are kept. The compartment should be large enough to house the boiler and ancillary equipment only.

**5. IT SHOULD NOT BE USED AS A STORAGE CUPBOARD.**

### 4.2 Check List

1. If a fault develops, or is suspected, call your installer or Service Engineer as soon as possible.

2. Go through the following check list before you make contact.

- a) Is the electricity supply on ?
- b) Is the selector switch on (giving a green "Power ON" neon) and set for both Central Heating and Domestic Hot Water ?
- c) Is the red "Flame Failure" neon lit ?  
Turn the On/Off/Reset selector fully anti-clockwise.
- d) Is the gas supply on ?
- e) Is the mains water supply turned on ?
- f) Is the system pressure correct ?
- g) Are the boiler temperature controls set high enough ?
- h) Is the time clock (if fitted) calling for central heating ?
- i) Is the room thermostat (if fitted) set high enough ?
- j) Are the radiator valves open ?

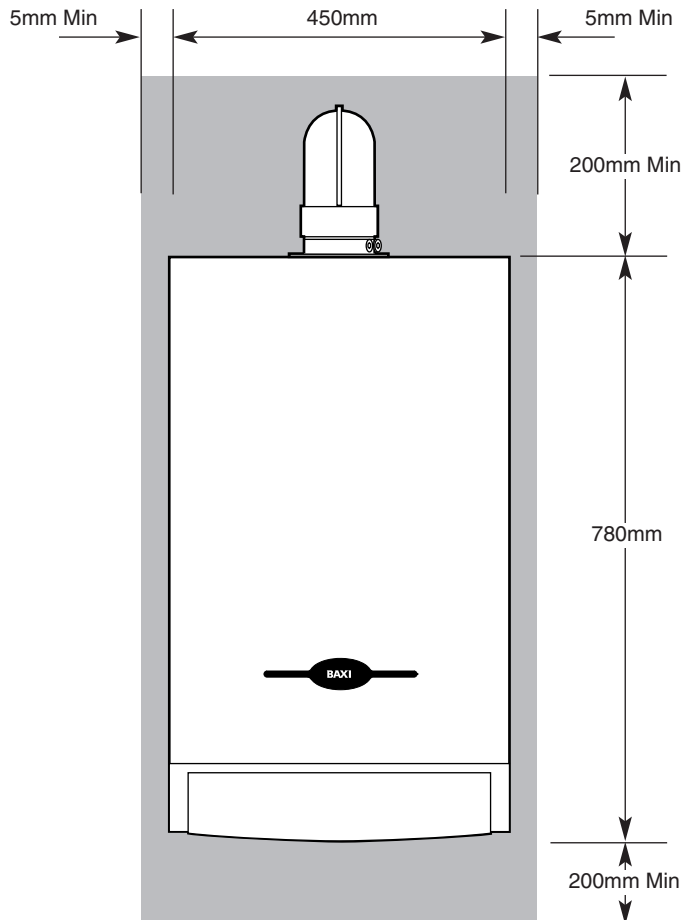

Fig. 23

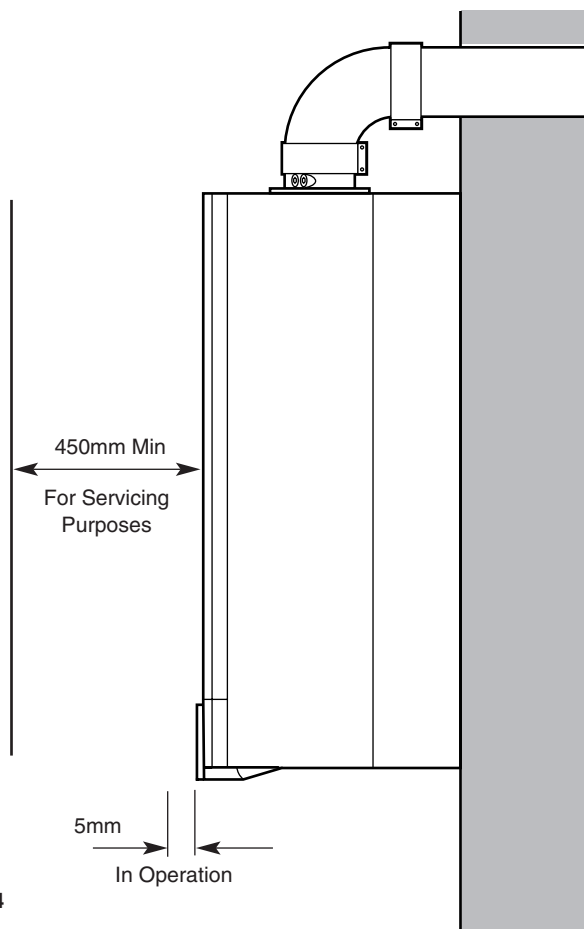

Fig. 24

## 5.0 Cleaning, Spares & Guarantee

---

### 5.1 Cleaning the Outercase

The painted panels should be wiped with a damp cloth and then dried completely. **DO NOT USE ABRASIVE CLEANING AGENTS.**

---

### 5.2 Spare Parts

**IMPORTANT** - Only a competent person should be used to service or repair this boiler.

1. Any repairs to the boiler will usually be the responsibility of the Installer during the guarantee period after which spare parts may be obtained through approved Baxi stockists if required.
  2. Quote the appliance name, model number and where possible the part number when ordering spares. A parts list is included in the Installation and Servicing Instructions.
  3. The name, model number and serial number can be found on the information label on the back of the hinged lower door.
- 

### 5.3 Guarantee

1. Your Baxi Combi Instant 80e or 105e is designed and produced to meet all the relevant Standards.
2. Baxi provide a 12 month guarantee on the boiler. The guarantee operates from the date installation is completed for the customer who is the original user.
3. To maximise the benefit from our guarantee we urge you to return the reply-paid guarantee registration.
4. This does not in any way prejudice your rights at Common Law. Such rights between the customer and the installer or supplier from whom the unit was purchased remain intact.

**Any component or part which becomes defective during the guarantee period as a result of faulty workmanship or material whilst in normal use will be repaired or replaced free of charge.**

---

When contacting Baxi Potterton please have the following information to hand:

Appliance Name  
Model Number  
Serial Number

A label giving these details is situated on the rear of the hinged lower door panel attached to the users operating instruction label.

