

Please keep these instructions safe.
Should you move house, please hand
them over to the next occupier.

Baxi Maxflow Combi WM

Gas Fired Wall Mounted Combination Boiler
with Unvented Hot Water Storage

User's Operating Instructions

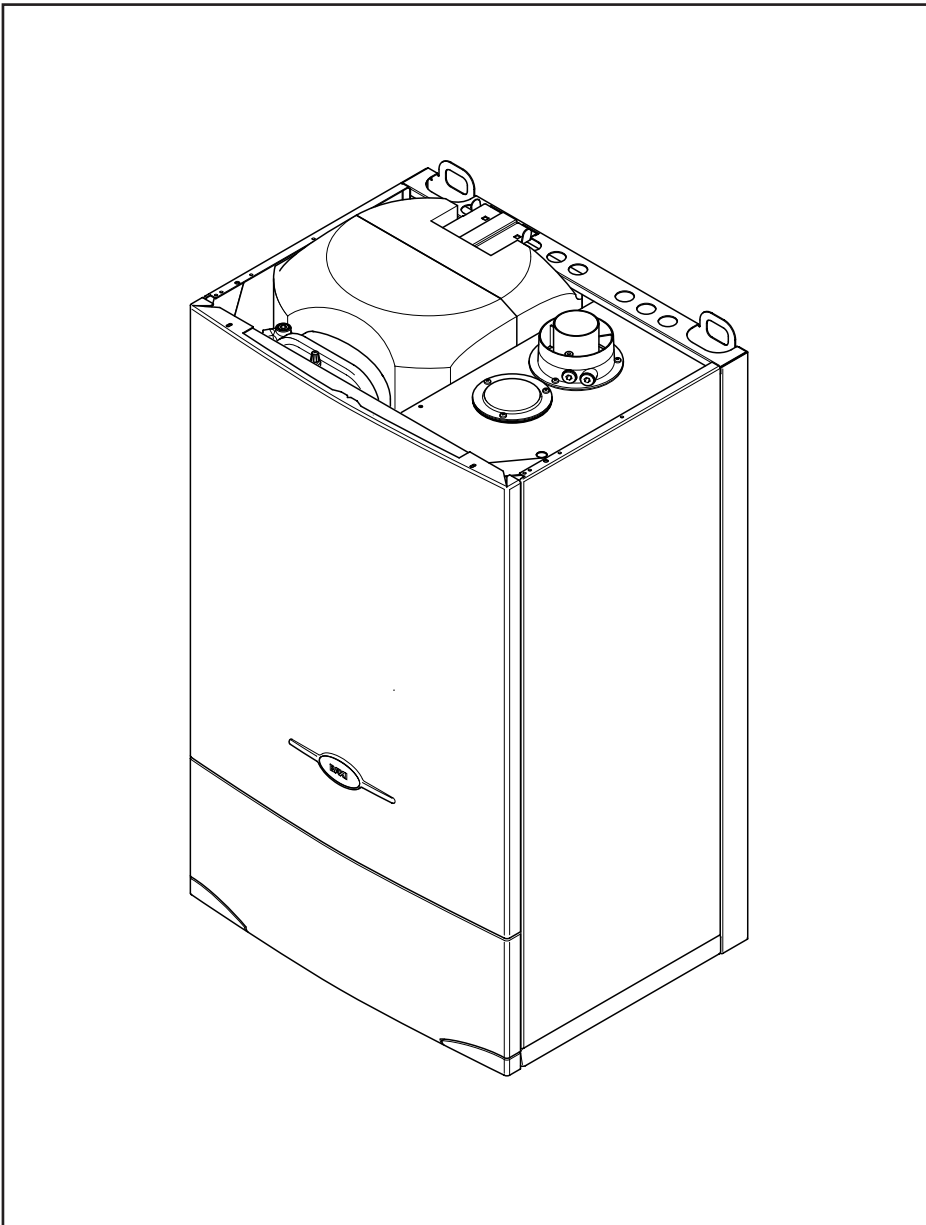

BAXI

Baxi Maxflow Combi WM
G.C.N° 47 075 03

Baxi UK Limited is one of the leading manufacturers of domestic heating products in the UK.

Our first priority is to give a high quality service to our customers. Quality is designed into every Baxi product - products which fulfil the demands and needs of customers, offering choice, efficiency and reliability.

To keep ahead of changing trends, we have made a commitment to develop new ideas using the latest technology - with the aim of continuing to make the products that customers want to buy.

Everyone who works at Baxi has a commitment to quality because we know that satisfied customers mean continued success.

We hope you get a satisfactory service from Baxi. If not, please let us know.

The boiler meets the requirements of Statutory Instrument "The Boiler (Efficiency) Regulations 1993 N° 3083" and is deemed to meet the requirements of Directive 92/42/EEC on the energy efficiency requirements for new hot water boilers fired with liquid or gaseous fuels:-

Type test for purpose of Regulation 5 certified by:
Notified Body 0051.

Product/Production certified by:
Notified Body 0051.

For GB/IE only.



Baxi is a BS-EN ISO 9001
Accredited Company

STANDARD	SCOPE
B.S. 6891	Gas Installation.
B.S. 5440: Pt 1	Flues.
B.S. 5440: Pt 2	Air Supply.
B.S. 5546	Installation of hot water supplies for domestic purposes.
B.S. 7074	Expansion vessels and ancillary equipment for sealed water systems.
B.S. 5449: Pt 1	Forced circulation hot water systems.
B.S. 6798	Installation of gas fired hot water boilers.

“Benchmark” Installation, Commissioning and Service Record Log Book

Please ensure that your installer has completed the Installation and Commissioning sections of the Log Book and hands the Log Book over. The details of the Log Book will be required in the event of any warranty work. Keep the Log Book in a safe place and ensure that the relevant sections are completed at each subsequent regular service visit. All CORGI registered installers carry a CORGI identification card and have a registration number. Both should be recorded in your boiler Log Book. You can check your installer is registered by telephoning 01256 372300 or writing to:-
1 Elmwood,
Chineham Business Park,
Crockford Lane,
Basingstoke
RG24 8WG

NOTE: Adjacent to the boiler at either the left or right hand side there will be fitted an expansion vessel, relief valve, tundish etc. These components must not be adjusted or interfered with in any way. They are part of the Unvented Hot Water Kit and are important safety items.

IN AN EMERGENCY

If a water or gas leak occurs or is suspected, the boiler can be isolated at the inlet valves as follows;

1. Turn off the electrical supply and turn the selector switch on the fascia to the OFF position (see 2.2).
2. The isolating valves are positioned under the boiler and can be closed using either a flat bladed screwdriver or an open ended spanner across the flats.
3. Turn the gas tap clockwise to the stop position to isolate the gas supply at the boiler.
4. To isolate the water system, close the three valves fully by turning clockwise.
5. Call your Service Engineer as soon as possible.

1.0 Warnings

1.1 Safe Installation

1. The appliance is suitable for installation only in G.B. and I.E. and should be installed in accordance with the rules in force. For Ireland install in accordance with I.S.813 “**INSTALLATION OF GAS APPLIANCES**”. The installation must be carried out by a CORGI Registered Installer or other registered competent person and be in accordance with the relevant requirements of current **GAS SAFETY** (Installation and Use) **REGULATIONS** most recent edition, the **BUILDING REGULATIONS** issued by the Department of the Environment, **BUILDING STANDARDS** (Scotland) (Consolidation) **REGULATIONS** issued by the Scottish Development Department and the **LOCAL BUILDING REGULATIONS**. Where no specific instructions are given, reference should be made to the relevant **BRITISH STANDARD CODES OF PRACTICE** and **INSTALLATION SPECIFICATIONS**.

2. **This appliance must be installed in accordance with the manufacturer’s instructions and the rules in force, and only used in a suitably ventilated location.**

3. **Read the instructions before installing or using this appliance.**

4. Any purpose provided ventilation should be checked periodically to ensure that it is free from obstruction.

IMPORTANT - The addition of anything that may interfere with the normal operation of the appliance without the express written permission of Baxi UK Limited could invalidate the appliance warranty and infringe the **GAS SAFETY** (Installation and Use) **REGULATIONS**.

1.2 In case of gas leaks

1. **If a gas leak is found or suspected**, turn off the gas supply at the meter immediately and at the isolating valve on the boiler if possible. Contact your Installer or Transco (under ‘Gas’ in the ‘phone directory).

1.3 Servicing your Appliance

1. For reasons of safety and economy your appliance should be serviced annually. Servicing must be performed by a competent person. Your Installer or British Gas Service will be able to advise you.

1.4 Electricity Supply

1. **THIS APPLIANCE MUST BE EARTHED.**

2. A standard 230V ~ 50Hz supply is required. The appliance must be protected by a 3 amp fuse.

Never Hang Flammable Items Over The Appliance

2.0 Operating the Boiler

2.1 Introduction

1. Your Baxi Maxflow Combi WM is a gas fired, room sealed, powered flue combination boiler, which provides central heating for your home and incorporates a 54 litre unvented hot water storage cylinder. It is fully automatic and does not have a pilot light. Frost and pump protection is an integral part of the appliance. The appliance will provide between 10.4 and 28.0 kW output.

2. Priority is given to the hot water mode - when a hot water tap is turned on the supply of heat to the radiators is interrupted. No reduction in room temperature should be apparent.

3. A shortened version of these operating instructions appears on the reverse of the lower door panel. A label gives details of the model, serial number, G.C.N° and the manufacturer's name and address.

2.2 Operating the Boiler

1. Ensure that the gas and electricity supplies are turned on and that all timers, thermostats etc. are calling for heat.

2. Hinge down the facia panel (Fig. 1). Check that the central heating pressure is in the green area on the gauge. The Power ON indicator will be lit (☉).

3. Turn the on-off selector switch either anti-clockwise from the off position (Fig. 3) to both central heating and domestic hot water or clockwise for domestic hot water only.

4. **Position (i)** In this position the boiler will heat the radiators according to demand or will heat the hot water storage cylinder as required (Fig. 4).

5. **Position (ii)** In this position the boiler will heat the hot water storage cylinder as required. (Fig. 5).

7. The boiler will light automatically on demand.

8. The Burner ON indicator (🔥) will light when the boiler is operating and the main burner has lit (Fig. 2).

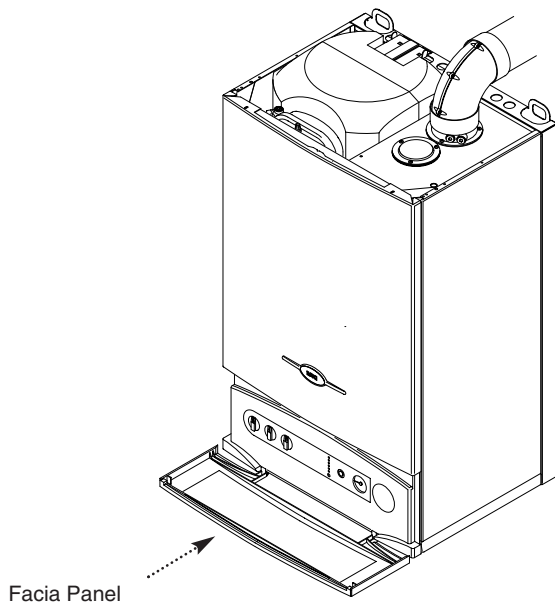

Fig. 1

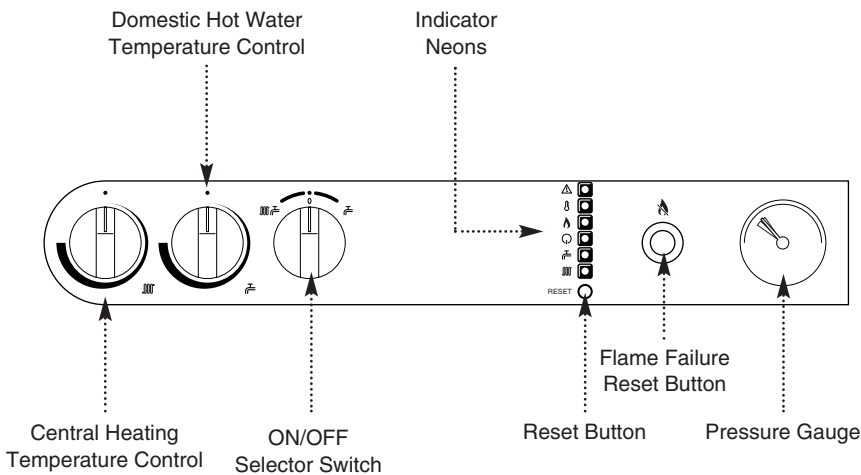

Fig. 2

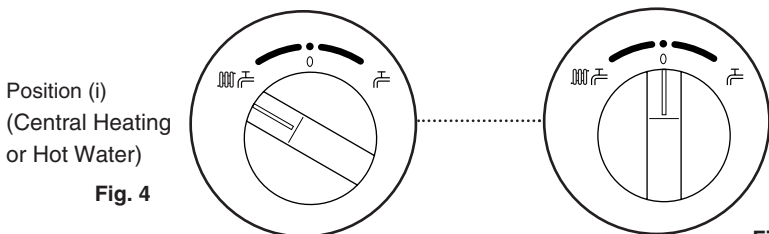

Fig. 3

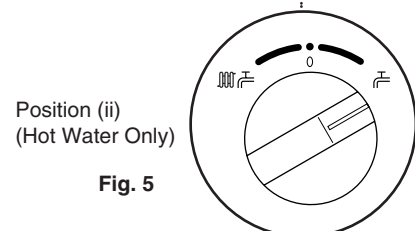

Fig. 4

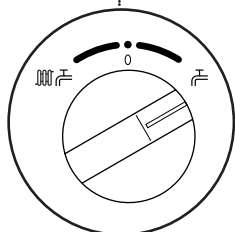

Fig. 5

IMPORTANT: When the selector switch is in the '0' (Off) position the electrical supply to the boiler is isolated. The boiler will not operate and the integral timer (if fitted) will require resetting once the selector switch is set to either the Position (i) or Position (ii).

2.0 Operating the Boiler

2.3 Temperature Control

1. **Central Heating:** The central heating hot water flow temperature can be adjusted between 30° C minimum and 82° C maximum.

2. Turn the control knob clockwise to increase the temperature (Fig. 6).

3. In normal winter usage we recommend that the central heating temperature be set at maximum.

4. **Domestic Hot Water:** The temperature of the domestic hot water can be adjusted up to a maximum of 65° C. Turn the control knob clockwise to increase the temperature (Fig. 7).

5. It may take a short while, and a degree of experimentation, to obtain the best performance from your Baxi Maxflow Combi as the appliance does not provide domestic hot water in the same manner as other combi or conventional boilers.

6. When the temperature control is set to maximum the domestic hot water as delivered will be too hot for bathing purposes without the addition of cold water. As a general recommendation, when the control knob is set between 90° and 180° clockwise from the OFF position the hot water will be delivered at a temperature suitable for most domestic requirements. This can be adjusted according to experience and personal requirements.

7. If the store has reached maximum selected temperature and a hot tap is turned on full to give a flow rate of approximately 16 litres/min., such as when filling a bath, it will take approximately 3 minutes to deplete the store. During this time the boiler will relight ( indicator neon will be illuminated). Unless the flow rate is reduced before the store is depleted the water temperature will not recover. By reducing the flow rate to around half (or less) approximately two minutes after first turning the tap on the temperature will be maintained.

8. If the tap is initially opened approximately half way to deliver a flow of 8 to 10 litres/min. the boiler will continue to provide hot water at the selected temperature.

9. As an example, with the temperature control set at maximum and the stored water fully heated a flow rate of 8 litres/min. will provide enough hot water for the average bath within 5 or 6 minutes. This would then require the addition of cold water for bathing comfort.

10. Other factors that will influence the performance are the temperature of the cold water supply to the boiler, the ambient air temperature both outside and in the room in which the hot water is being drawn off, the distance from the boiler to the point of draw off, pipe insulation etc.

11. When demand ceases, the boiler will quickly and automatically replenish the store of hot water to the selected temperature.

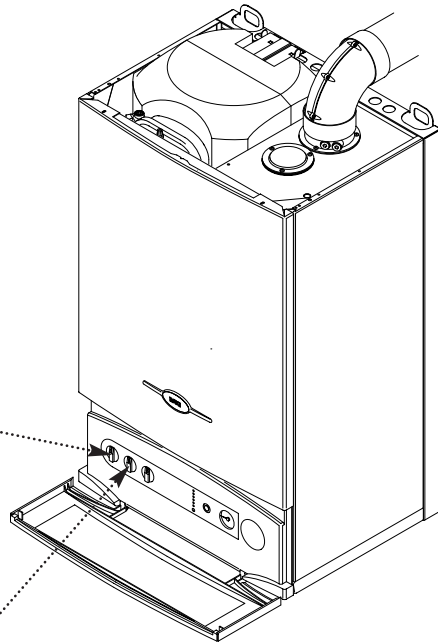

Fig. 6
Central Heating
Temperature Control

Fig. 7
Domestic Hot Water
Temperature Control

2.0 Operating the Boiler

2.4 Indicator Neons

1. The appliance is fitted with six vertically aligned status indicator neons, and one illuminated reset button. The indicators are:-

- △ Air Flow Monitor
- ⊗ Safety Thermostat
- 🔥 Burner On
- ⌚ Power To Boiler
- ⌚ Boiler Supplying DHW
- ⌚ Boiler Supplying CH

The illuminated reset button is below the 🔥 symbol.

2.5 Air Flow Monitor Indicator

1. The boiler is fitted with an air pressure sensing device. This monitors the flue system.

2. On starting the boiler the indicator (△) will be on while the sensor checks that the fan is functioning correctly (Fig. 8).

3. If the neon stays on permanently it indicates that the flue or flue terminal is blocked or obstructed in some way, or that there is an internal fault. If there is no external blockage of the flue terminal that can be easily removed contact your Service Engineer.

2.6 Safety Thermostat Indicator

1. Your Baxi Maxflow Combi WM is fitted with an additional safety device, which shuts down the boiler in the event of the system or the boiler overheating.

2. If the device operates, the safety thermostat indicator will light (⊗) and the boiler will shut down.

3. **To reset:** Press the white reset button (below the indicator lights) to relight the boiler (Fig. 8).

4. If the safety thermostat operates repeatedly, causing boiler shutdown, a fault is indicated. Your Service Engineer should be contacted as soon as possible.

2.7 Burner On Indicator

1. The indicator (🔥) will illuminate once the burner has ignited. When the burner goes out the indicator will be extinguished.

2.8 Supply Indicators

1. The supply indicators show whether the boiler is satisfying the Domestic Hot Water demand (⌚) or the Central Heating (⌚).

2.9 Flame Failure Reset Button

1. The reset button below the (🔥) symbol will illuminate in the event of the burner failing to light, or when incomplete lighting of the burner occurs.

2. Pressing the button will restart the ignition sequence. If the reset button illuminates repeatedly a fault is indicated. Your Service Engineer should be contacted as soon as possible.

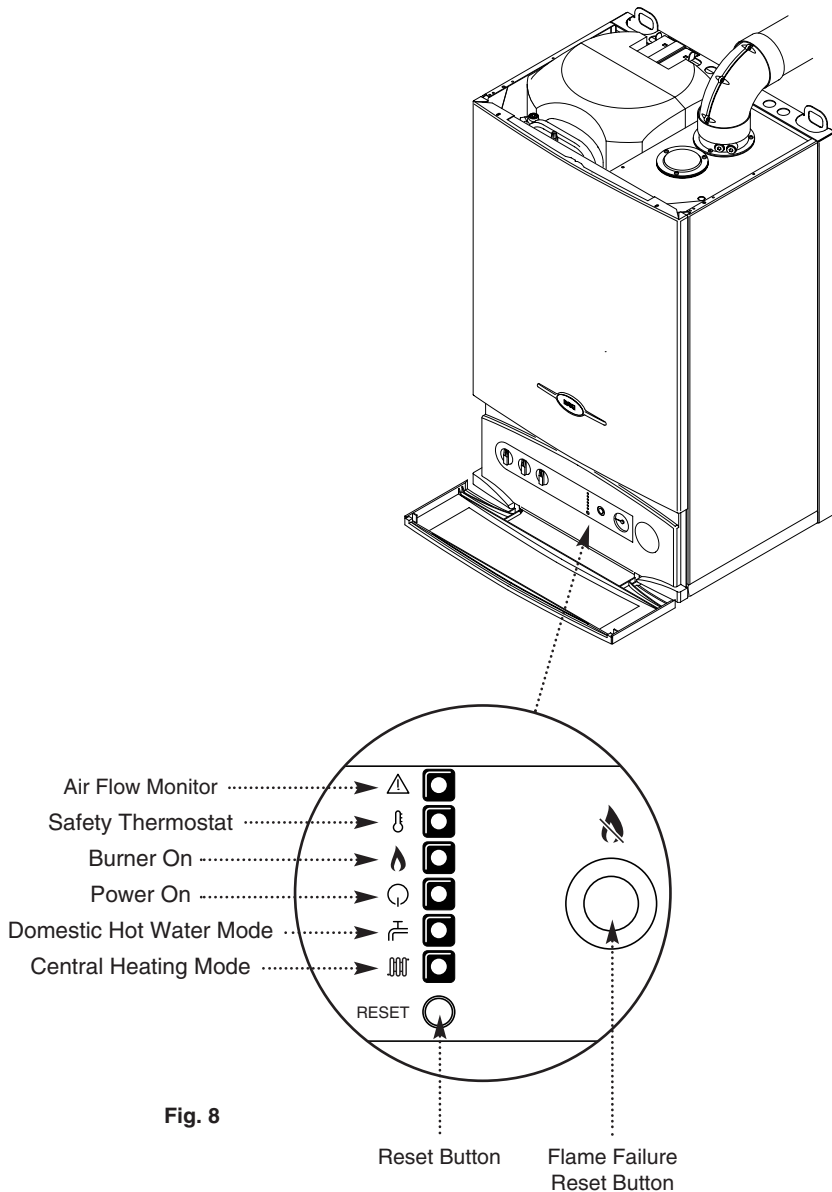
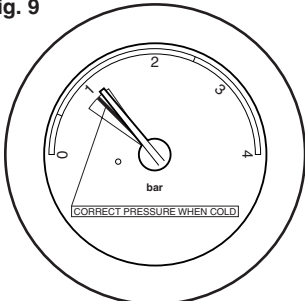

Fig. 8

2.0 Operating the Boiler

Fig. 9



Correct pressure when cold

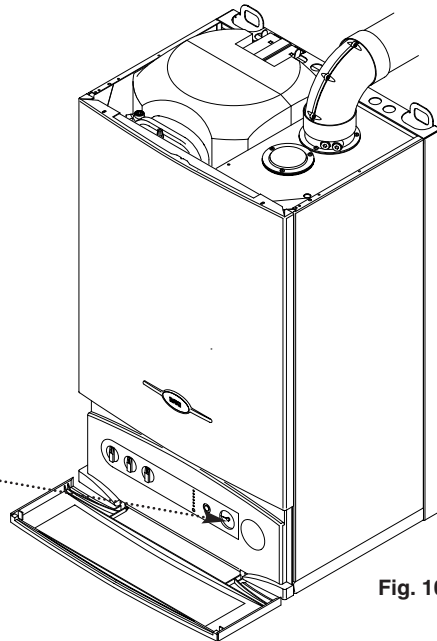



Fig. 10

2.10 Central Heating System Pressure

1. The water pressure in the central heating system is indicated by the pressure gauge.
2. The recommended system pressure when cold is 1.0 bar (Fig. 9). The minimum pressure is 0.5 bar (Fig. 11), the maximum is 2.5 bar (Fig. 12).
3. A pressure of 2.5 or greater indicates a fault. The safety pressure relief valve will operate at a pressure of 3. It is important that your Service Engineer is contacted as soon as possible in the event of over pressurisation of the system.
4. The MINIMUM pressure for correct operation is 0.5 (Fig. 11). If the pressure falls below 0.5, this may indicate a leak on the central heating system. Below 0.5 the boiler will not function.
5. The system must be checked and re-pressurised by your Service Engineer.

2.11 To Shut Off the Boiler

1. **For short periods:** Turn the selector switch to the DHW position ( , Fig. 14).
2. **For longer periods:** Turn the selector switch to the OFF position (Fig. 15) and turn off the electricity and gas supplies.

If your home is to be left unoccupied for long periods during cold weather the boiler and whole system should be drained unless there is additional frost protection.

3. Your installer will advise you about frost protection and draining the system.

IMPORTANT: When the selector switch is in the '0' (Off) position the electrical supply to the boiler is isolated. The boiler will not operate and the integral timer (if fitted) will require resetting once the selector switch is set to either the Position (i) or Position (ii).

Fig. 11

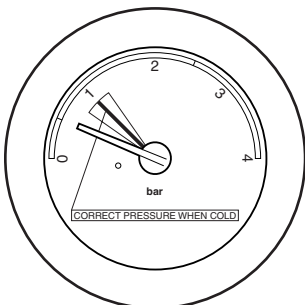

Minimum operating pressure

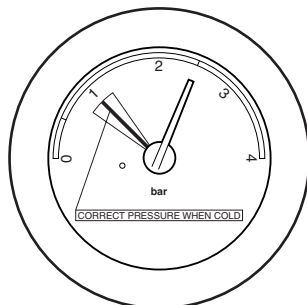

Maximum operating pressure

Fig. 12

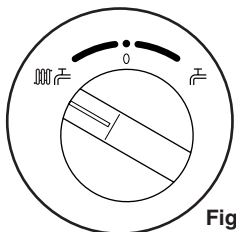

Fig. 13

Central Heating and Domestic Hot Water

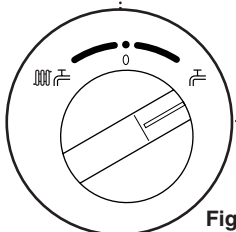

Fig. 14

Domestic Hot Water

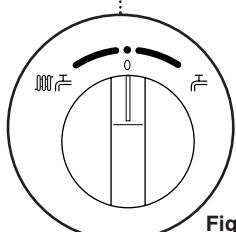

Fig. 15

OFF Position

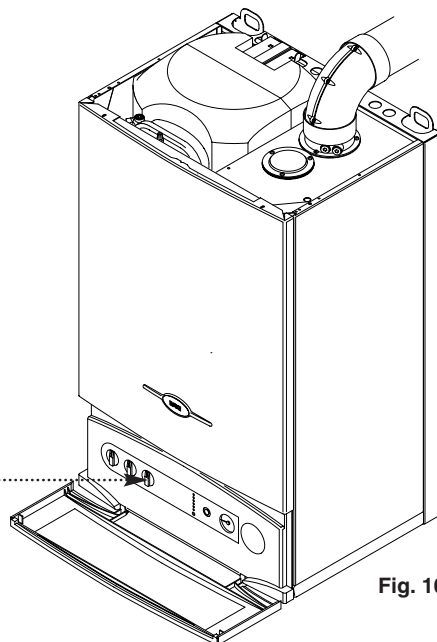

Fig. 16

2.12 Frost Protection Mode

1. The frost protection feature will operate when the selector switch is in the central heating and domestic hot water mode. The gas and electrical supplies to the boiler must be on and the system pressure must be within the range described in Section 2.10.
2. If the system temperature falls below 5° C, then the boiler will fire until the water temperature has been raised.
3. Further frost protection can be incorporated by using a frost thermostat to protect the whole system.

2.13 Pump Protection

1. With the selector switch in either operating position (Figs. 13 & 14) the pump will automatically operate for 1 minute in every 24 hours to prevent sticking.

3.0 Clearances

3.1 Clearances around the Boiler (Figs. 17 & 18)

1. The minimum clear spaces needed around the boiler measured from the casing are as follows:

Top	-	200mm
Bottom	-	250mm
Left hand side	-	20mm
Right hand side	-	5mm
Front	-	450mm (For Servicing) 5mm (In operation)

2. **These areas must not be obstructed in any way. Blocking the clearance spaces may result in the boiler overheating and damage may occur.**

3. The gas burning compartment of your boiler is completely sealed from the room in which it is fitted. Products from the combustion of gas are vented to the outside through the flue terminal which must be kept free from obstruction as this would interfere with the correct operation of the boiler.

4. The boiler may be installed in a cupboard or compartment if the following clearances are kept:-

Top	-	No clearances required
& Bottom	-	if non-combustible material is used between the boiler and compartment panels.
Both sides	-	45mm
Front	-	40mm

The compartment should be large enough to house the boiler and ancillary equipment only.

5. IT SHOULD NOT BE USED AS A STORAGE CUPBOARD.

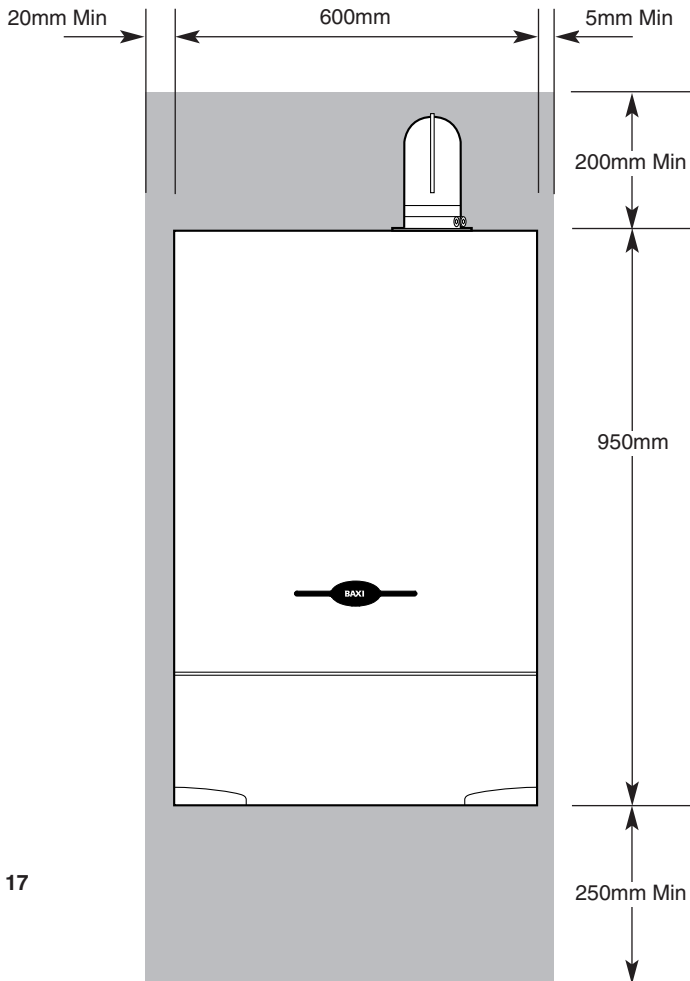

Fig. 17

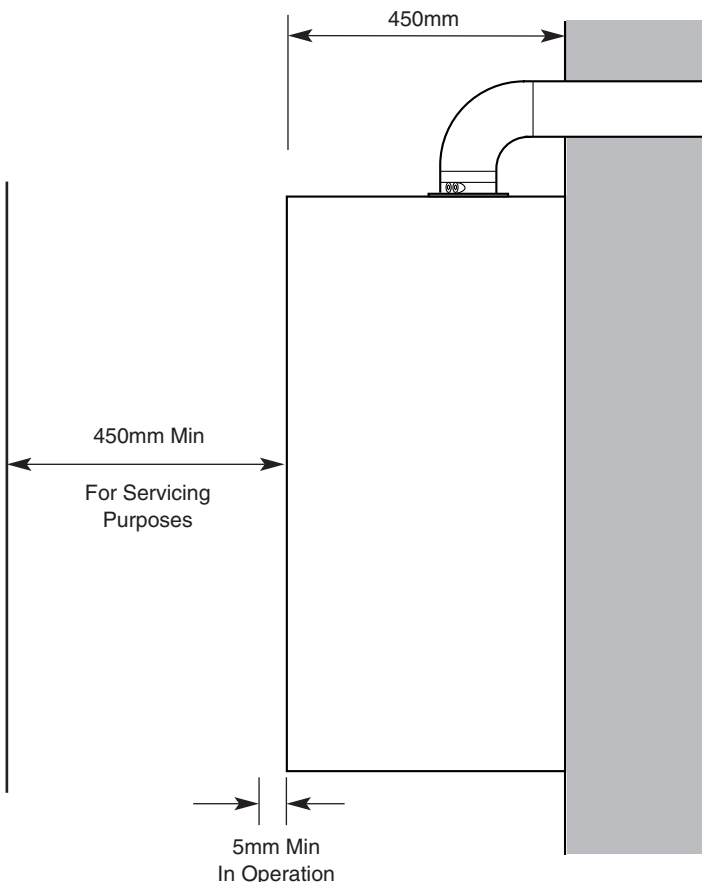

Fig. 18

4.0 Check List

4.1 Check List

1. If a fault develops, or is suspected, call your Service Engineer as soon as possible.

 2. Go through the following check list before you make contact.
 - a) Are the gas and electricity supplies on ?
 - b) Is the selector switch on and set for both Central Heating and Domestic Hot Water ?
 - c) Is the red "Flame Failure" reset button lit ?
If so, press the Reset Button.
 - d) Is the overheat indicator lit ?
If so, press the white Reset Button.
 - e) Is the mains water supply turned on ?
 - f) Are the boiler temperature controls set high enough ?
 - g) Are the time clock and room thermostat (where fitted) calling for heat ?
 - h) Are all the radiator valves open ?
-

5.0 Cleaning, Spares & Guarantee

5.1 Cleaning the Outercase

The painted panels should be wiped with a damp cloth and then dried completely. **DO NOT USE ABRASIVE CLEANING AGENTS.**

5.2 Spare Parts

IMPORTANT - Only a competent person should be used to service or repair this boiler

1. Any repairs to the boiler will usually be the responsibility of the Installer during the guarantee period after which spare parts may be obtained through approved Baxi stockists if required.

2. Quote the appliance name, model number and where possible the part number when ordering spares. A short parts list is included in the Installation and Servicing Instructions.

5.3 Guarantee

1. Your Baxi Maxflow Combi WM is designed and produced to meet all the relevant Standards.

2. Baxi UK Limited provide a 12 month guarantee on the boiler. The guarantee operates from the date installation is completed for the customer who is the original user.

3. To maximise the benefit from our guarantee we urge you to return the reply-paid guarantee registration.

4. This does not in any way prejudice your rights at Common Law. Such rights between the customer and the installer or supplier from whom the unit was purchased remain intact.

Any component or part which becomes defective during the guarantee period as a result of faulty workmanship or material whilst in normal use will be repaired or replaced free of charge.

Baxi UK Limited manufacture a comprehensive range of products for the domestic heating market.

**Gas Central Heating Boilers
(Wall, Floor and Fireside models).**

Independent Gas Fires.

Renewal Firefronts.

Gas Wall Heaters.

Solid Fuel Fires.

If you require information on any of these products, please write, telephone or fax to the Sales Department.

After Sales Service
08706 096 096

BAXI

Baxi UK Limited
Brownedge Road
Bamber Bridge Preston
Lancashire
PR5 6SN
www.baxi.com