



# *Riva 53DV, 67DV & 70DV*

## *Balanced Flue Convector Fire Range*

With upgradeable control valve

## **Instructions for Use, Installation and Servicing**

**For use in GB, IE (Great Britain and Eire)**

This appliance has been certified for use in countries other than those stated. To install this appliance in these countries, it is essential to obtain the translated instructions and in some cases the appliance will require modification. Contact Gazco for further information.

### **IMPORTANT**

**Do not attempt to burn rubbish in this appliance. This appliance must only be operated with the glass door secured firmly in position. The front casing of this appliance will become hot whilst in operation, it is therefore recommended that a suitable guard should be used for the protection of young children, the elderly or infirm.**

**Please read these Instructions carefully before installation or use.**

**Keep them in a safe place for future reference and when servicing the fire.**

**The commissioning sheet found at the end of the Users Sections of these instructions should be completed by the Installer.**

**LPG Models: The appliance is factory set to be run on Butane G30.**

**If it is intended to be used on Propane G31 the aeration plate supplied must be fitted.**

# CONTENTS

## COVERING THE FOLLOWING MODELS

53DV	67DV	70DV
8592	8595	8597
P8592	P8595	P8597

	<b>PAGE</b>
<b>APPLIANCE COMMISSIONING CHECKLIST</b>	<b>3</b>
<b>USER INSTRUCTIONS</b>	<b>4</b>
<b>INSTALLATION INSTRUCTIONS</b>	<b>9</b>
Technical Specifications	9
Site Requirements	11
Installation	17
Commissioning	24
<b>SERVICING INSTRUCTIONS</b>	<b>25</b>
Servicing Requirements	25
Fault Finding	26
How to replace parts	27
Basic spare parts list	31

# APPLIANCE COMMISSIONING CHECKLIST

## IMPORTANT NOTICE

Explain the operation of the appliance to the end user, hand the completed instructions to them for safe keeping, as the information will be required when making any guaranteed claims.

FLUE CHECK	PASS	FAIL	
1. Flue is correct for appliance			
2. Flue flow test N/A			
3. Spillage test N/A			
GAS CHECK			
1. Gas soundness & let by test			
2. Standing pressure test	mb		
3. Appliance working pressure (on High Setting) NB All other gas appliances must be operating on full	mb		
4. Gas rate	m <sup>3</sup> /h		
5. Does ventilation meet appliance requirements N/A			
6. Have controls been upgraded (Upgradeable models only)	8455 Standard	YES	NO
	8456 Programmable Thermostatic and Timer	YES	NO

## DEALER AND INSTALLER INFORMATION

Dealer.....

.....

.....

Contact No. ....

Date of Purchase.....

Model No.....

Serial No.....

Gas Type.....

Installation Company.....

.....

.....

Engineer .....

Contact No. ....

Corgi Reg No.....

Date of Installation.....

# USER INSTRUCTIONS

## 1. GENERAL

- 1.1 A competent person must carry out installation and servicing.
- 1.2 In all correspondence, please quote the appliance type and serial number, which can be found on the databadge located on a plate under the appliance.
- 1.3 Ensure that curtains are not positioned above the appliance and there is at least 300mm between the sides of the appliance and any curtains.
- 1.4 If any cracks appear in the glass panel do not use the appliance until the panel has been replaced.
- 1.5 If, for any reason, the flue has to be removed from the appliance, the seals must be replaced in the inner spigot.
- 1.6 Do not obstruct the flue terminal in any way, i.e. by planting flowers, trees, shrubs etc in the near vicinity, or by leaning objects up against the terminal guard.
- 1.7 Do not use a garden sprinkler or hose near the terminal.
- 1.8 Do not stand or place objects on the terminal guard as this will deform it.

This product is guaranteed for 12 months from the date of installation, as set out in the terms and conditions of sale between Gazco and your local Gazco dealer. Please consult with your local Gazco dealer if you have any questions. In all correspondence always quote the Model Number and Serial Number.

## 2. LIGHTING THE RIVA

- 2.1 Locate the control valve on the appliance. There are two control knobs on the valve, the right hand knob controls the pilot ignition and the left hand knob controls the main burner.

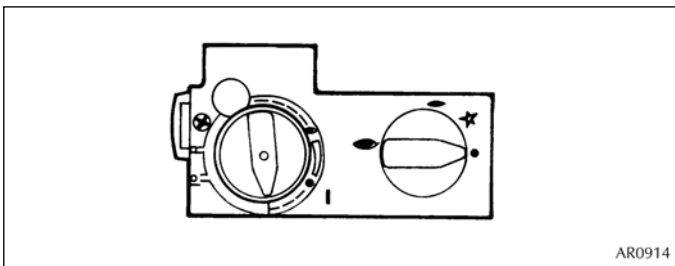

AR0914

- 2.2 If your appliance has already been upgraded to battery remote control, please refer to the instructions provided with the upgrade to operate the remote control. The following instructions will work for either situation.
- 2.3 Ensure that the left hand control knob is pointing to off (●).
- 2.4 Ensure that the right hand control knob is pointing to off (●).
- 2.5 Press in the right hand control knob and rotate it anti-clockwise until a click is heard (keep pressing in) and the knob is pointing to pilot (☛). The pilot should now light. If the pilot has not lit, repeat the procedure until it does.

- 2.6 Keep the control knob pressed for 10 seconds and then release it, the pilot should stay alight. If the pilot goes out, repeat the procedures until it does.
- 2.7 If the pilot will not light after repeated attempts, contact the retailer or installer from whom the appliance was purchased.
- 2.8 Turn the right hand control to point to main burner (☛). The appliance can now be controlled using the left hand control knob.
- 2.9 Turn the left hand control knob to point to low fire (☛), the main burner will light on low. The burner can now be controlled between low and high settings. Turn the control knob anticlockwise to increase the flame height and clockwise to decrease the flame height.

**THE YELLOW FLAMES WILL APPEAR WHEN THE FIRE HAS GAINED SUFFICIENT HEAT - TYPICALLY 10 TO 20 MINUTES.**

## 3. TURNING THE RIVA OFF

- 3.1 To turn the Riva off, locate the control valve, turn the left hand control knob until it points to off (●). The main burner will go out leaving the pilot burning.
- 3.2 To turn the pilot off, locate the control valve, turn the right hand control knob until it points to off (●), the pilot will go out.

**IF THE FIRE IS EXTINGUISHED OR GOES OUT IN USE, WAIT 3 MINUTES BEFORE ATTEMPTING TO RELIGHT THE FIRE. THE CONTROL VALVE HAS AN INTERLOCK DEVICE AND THEREFORE CANNOT BE LIT UNTIL THE 3 MINUTES HAVE ELAPSED.**

## 4. UPGRADING YOUR RIVA

- 4.1 Your Riva is fitted with a control valve that can easily be upgraded to battery powered remote control. This upgrade can be fitted by anyone capable of simple DIY jobs and requires no special training. There are two versions of this control which can be obtained through your local Gazco stockist.
- 4.2 **STANDARD REMOTE CONTROL** This remote control can control the gas appliance after the pilot has been lit. It can turn the main burner on and regulate it from low through to high and back again. It can turn the main burner off leaving the pilot burning. GAZCO PART NUMBER 8455.
- 4.3 **PROGRAMMABLE THERMOSTATIC AND TIMER REMOTE CONTROL** This remote control can control the gas appliance after the pilot has been lit. In 'MANUAL MODE' it can be used to turn the main burner on and manually regulate it from low through to high and back again. It can also be used to turn the main burner off leaving the pilot burning. In 'AUTO MODE' it will automatically regulate the room temperature to a pre-set temperature. In 'TIMER MODE' it will turn the fire on and off according to a pre-set programme and automatically regulate the room temperature during the two on periods. GAZCO PART NUMBER 8456.

# USER INSTRUCTIONS

RIVA 67DV & 70DV

## 5. CLEANING THE RIVA

**ENSURE THE APPLIANCE IS COLD BEFORE PROCEEDING.**

- 5.1 Remove the Profil frame from the appliance by removing the 2 concealed screws behind the lower access door. See diagram 1. Pull the frame forward at the bottom then lift clear of the top fixing lugs.

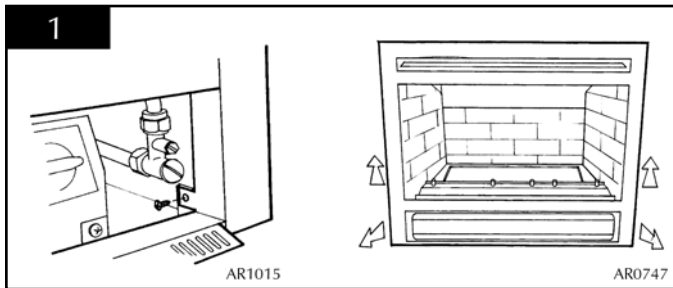

NOTE: If the appliance is fitted with an alternative Gazco Riva front, please refer to the separate leaflet supplied with the front.

- 5.2 Remove the glass door by unscrewing the nine screws. See diagram 2.

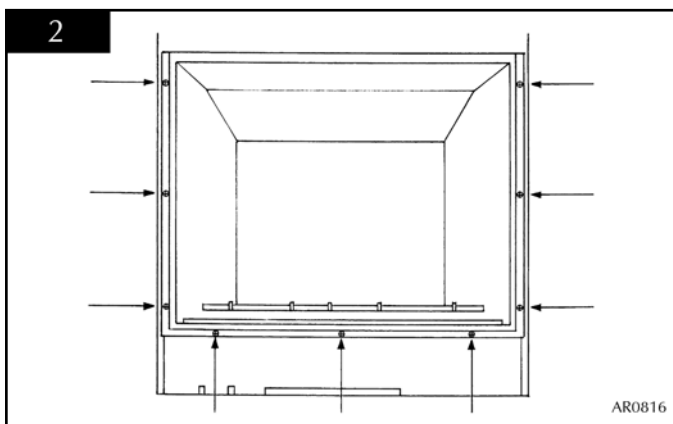

- 5.3 Remove the ceramic logs and place on a dry, clean surface. It is not essential to remove the vermiculite.
- 5.4 The logs should not require cleaning. Do not use a vacuum cleaner or brush to clean the logs, any large pieces of debris may be removed by hand.
- 5.5 Ensure any debris is removed from the burner ports.
- 5.6 Replace the ceramics and door by referring to section 5.
- 5.7 Use a damp cloth to clean the outer casing of the appliance.

## 6. ARRANGEMENT OF FUEL BED COMPONENTS

### RIVA 67DV & 70 DV

**THE BAG OF VERMICULITE CONTAINED IN THE LOG SET IS TO SIMULATE AN ASH EFFECT. THIS IS NOT TO BE PLACED ON THE BURNER.**

- 6.1 Fill the front compartment where the log location studs are attached. The vermiculite must only reach the top of the front and rear flanges. Place vermiculite around the rear and sides of the burner tray. **ENSURE NO VERMICULITE FALLS ON THE BURNER.** See diagram 3.

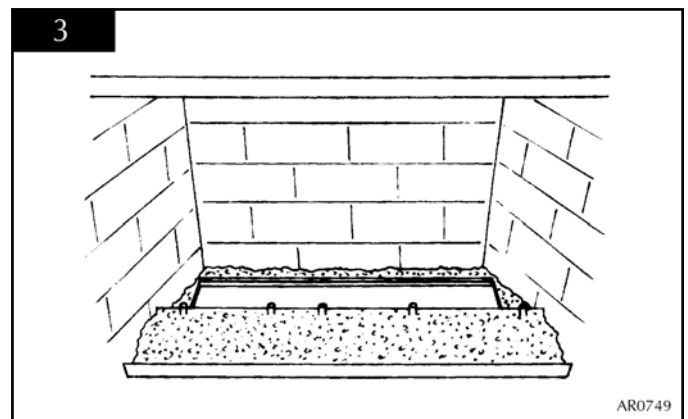

- 6.2 Place log 1 (large black log) on the burner. Ensure the rear of the log touches the rear of the burner. See diagram 4.

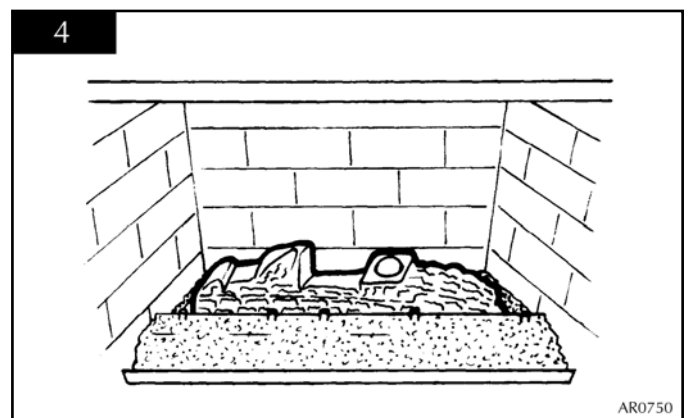

**CENTRALISE THE LOG BETWEEN THE BURNER PORTS AT EITHER END.**

**ALL THE REMAINING LOGS EXCEPT FOR THE SMALLEST ONE HAVE LOCATION HOLES ON THE UNDERSIDE, THESE LOCATE ON THE STUDS AT THE FRONT OF THE FIRE.**

# USER INSTRUCTION

## RIVA 67DV & 70DV

- 6.3 Place log 2 on the centre and locate the rear of the log on the large flat area of log 1. See diagram 5.

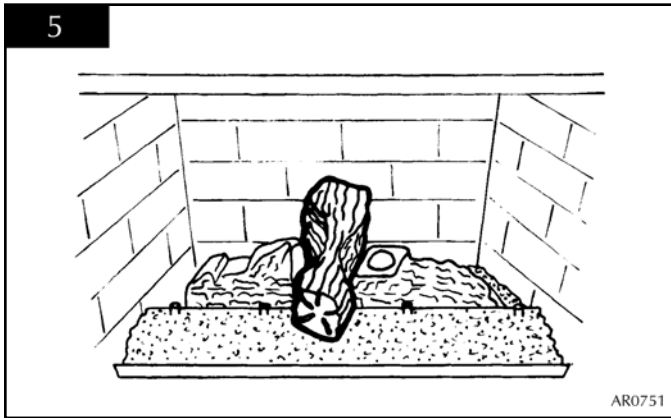

- 6.4 Place log 3 on the far left-hand stud. The recess on the underside of the log should locate on the top of log 1 on the far left-hand side. See diagram 6.

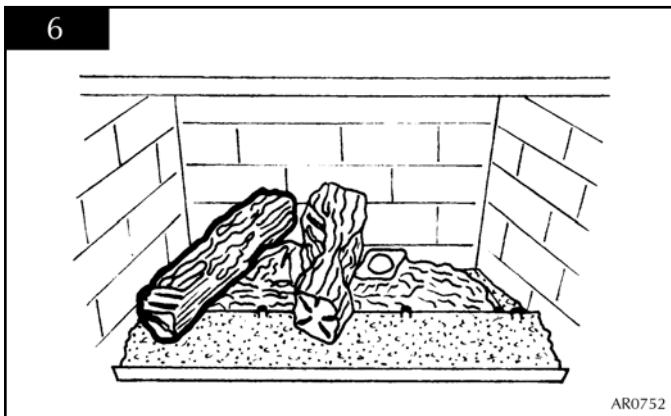

- 6.5 Place log 4 on the right hand side of the centre log. There is a large recess on the underside of the log, which locates on log 1. See diagram 7.

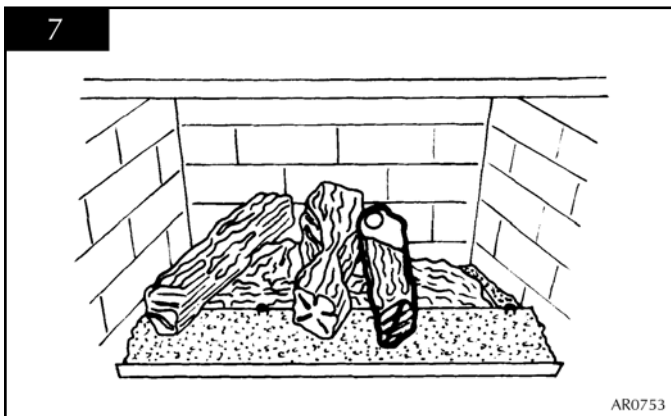

- 6.6 Place log 5 on top of log 4 and ensure the two large locations engage. Locate the front of the log on to the far right hand stud. See diagram 8.

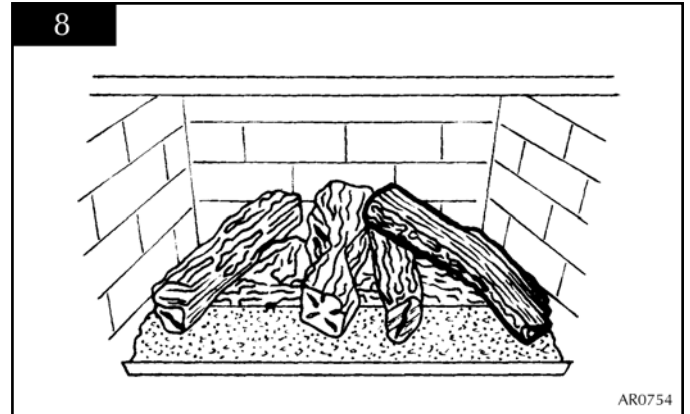

- 6.7 Place log 6 on the remaining stud and lean the log on to log 1 between logs 2 and 3. There is a notch to locate the log. See diagram 9.

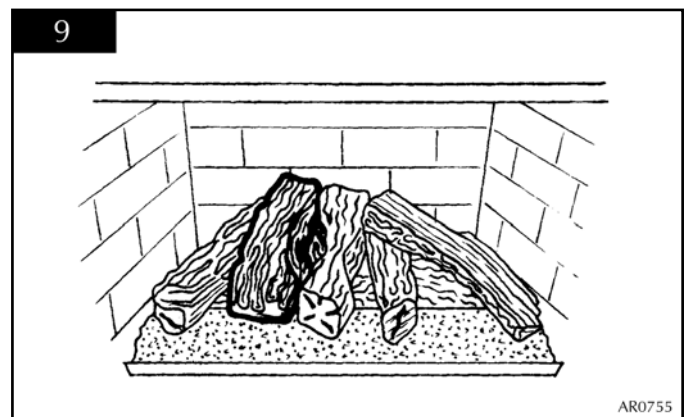

- 6.8 Place log 7 on the vermiculite at the front of the fire between logs 4 and 5. **DO NOT PLACE THIS LOG ON THE BURNER. IT IS ONLY TO FILL THE GAP BETWEEN LOGS 4 AND 5.** The charred effect should face the rear of the fire. See diagram 10.

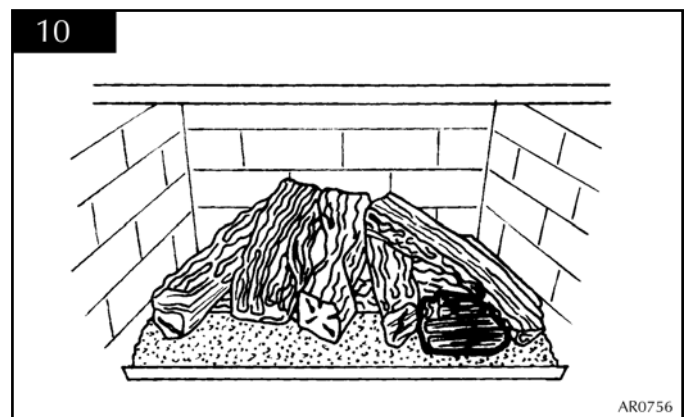

# USER INSTRUCTIONS

## RIVA 53DV

### RIVA 53DV

- 6.9 Place log A on to the burner. Ensure the rear of the log touches the rear of the burner. See diagram 11.

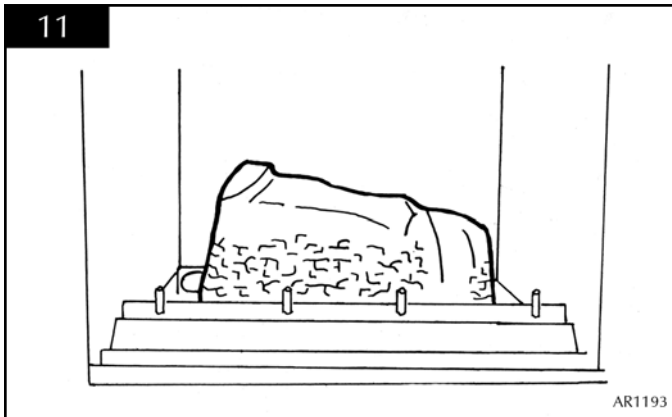

CENTRALISE THE LOG BETWEEN THE BURNERPORTS AT EITHER END.

Four of the remaining logs have location holes on the underside. These locate on the studs at the front of the fire.

- 6.10 Place log D on the third stud from the left and resting at the rear on log A. See diagram 12.

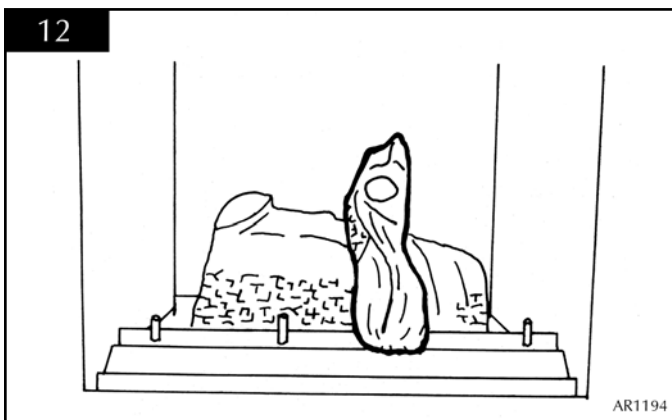

- 6.11 Place log C on the second stud and resting at the rear on log A. See diagram 13.

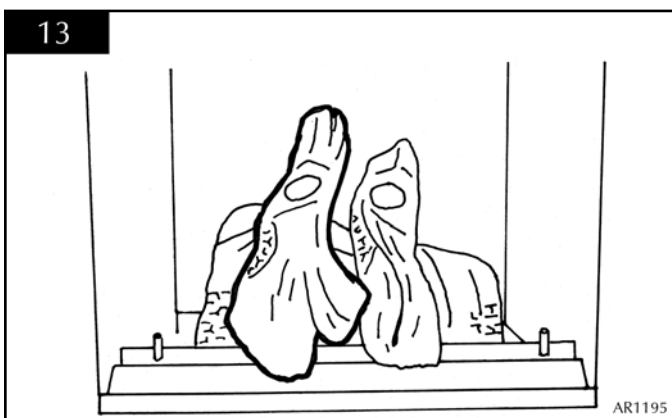

- 6.12 Place log B on the first stud. The recess on the underside of the log should locate on to the top of log C. See diagram 14.

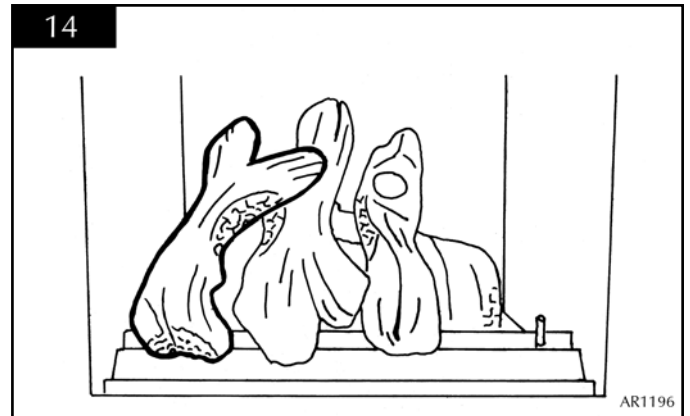

- 6.13 Place log E on to the last stud. The recess on the underside of the log should locate on to the top of log D. See diagram 15.

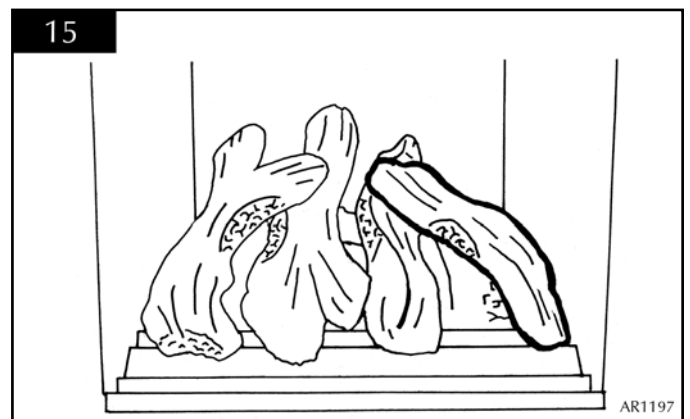

- 6.14 Place log F resting on the rear tray and leaning forward to locate in the recess in log E. See diagram 16.

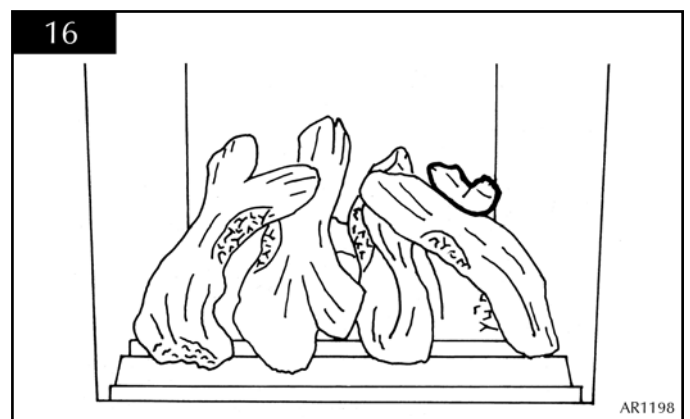

# USER INSTRUCTIONS

RIVA 53DV

ALL RIVA

- 6.15 Place log G at the front of the fire between logs D and E. **DO NOT PLACE THIS LOG ON THE BURNER. IT IS ONLY TO FILL THE GAP BETWEEN LOGS D AND E.** The charred effect should face the rear of the fire. See diagram 17.

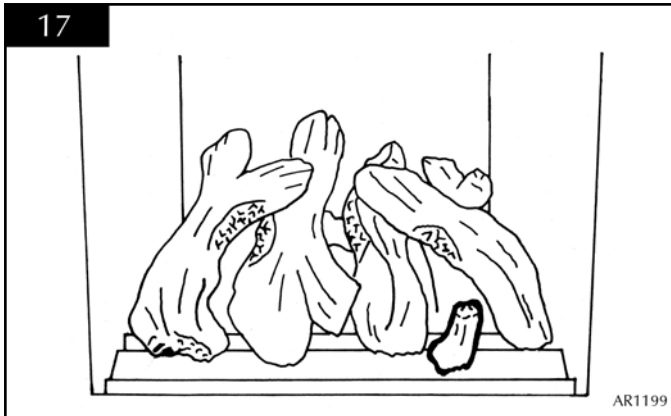

- 6.16 With the granules fill the front compartment around the logs evenly. **ENSURE NO GRANULES FALL ON THE BURNER.** See diagram 18.

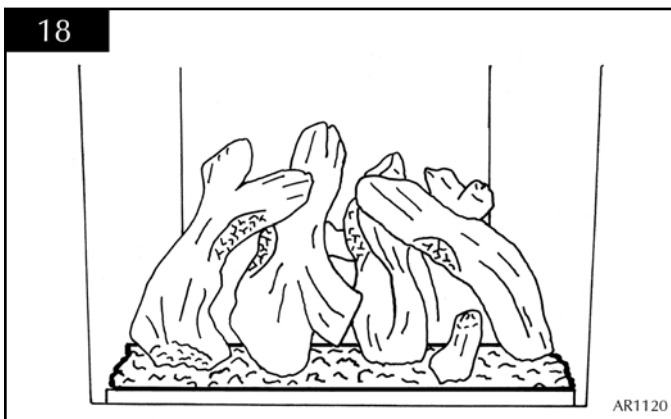

## RIVA 53DV, 67DV & 70 DV

- 6.17 Ensure that the fibreglass seal on the back of the glass frame is intact then hook the location tabs over the hooks on the top of the firebox. Replace the nine screws working from the top down. Tighten the screws evenly. **DO NOT OVER TIGHTEN.** See diagram 2, Section 5 'Cleaning the Riva'.  
**NEVER OPERATE THE APPLIANCE WHEN THE GLASS PANEL IS REMOVED OR BROKEN.**
- 6.18 Replace the decorative frame by hooking the top over the location lugs on top of the flanges, replace the two fixing screws, see diagram 1, Section 5 'Cleaning the Riva'.  
**NOTE:** If the appliance is fitted with an alternative Gazco Riva front, please refer to the separate leaflet supplied with the front.  
**NOTE:** ENSURE THAT THE LOGS ARE POSITIONED AS ABOVE. ONLY USE THE CORRECT AMOUNT OF LOGS AS SPECIFIED IN THE DIAGRAMS.

## 7. FLAME FAILURE DEVICE

- 7.1 This is a safety feature incorporated on this appliance which automatically switches off the gas supply if the pilot goes out and fails to heat the thermocouple.

## 8. RUNNING IN

- 8.1 The surface coating on the logs used in your GAZCO fire will "burn off" during the first few hours of use producing a harmless and temporary odour. This will disappear after a short period of use. If the odour persists, ask your installer for advice.

## 9. SERVICING

- 9.1 The fire must be serviced every 12 months by a qualified Gas Engineer. In all correspondence always quote the Model number and the Serial number which may be found on the databadge.

## 10. VENTILATION

- 10.1 Any purpose provided ventilation should be checked periodically to ensure that it is free from obstruction.

## 11. INSTALLATION DETAILS

- 11.1 To assist in any future correspondence, your installer should have completed the commissioning sheet at the front of this book, this records the essential installation details of the appliance. In all correspondence always quote the Model number and Serial number.

## 12. HOT SURFACES

- 12.1 Parts of this appliance become hot during normal use. It is therefore recommended that a suitable fire guard be used for protection of young children and the infirm. Indeed, all parts of the appliance should be treated as a 'working surface' except for the control access panel. If frames other than the Profil are being fitted, refer to their instructions.

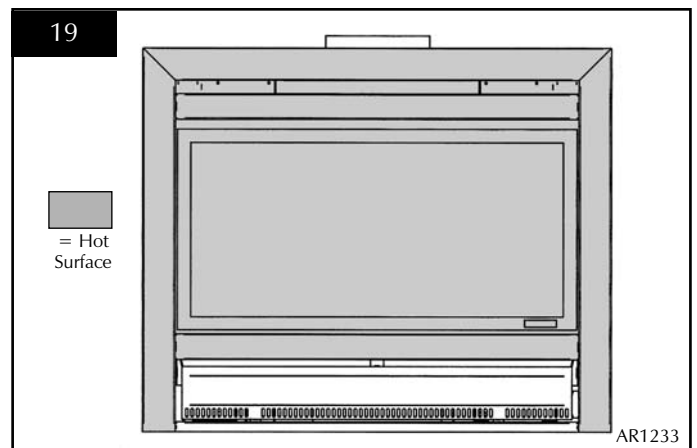



# INSTALLATION INSTRUCTIONS

## TECHNICAL SPECIFICATION

### COVERING THE FOLLOWING MODELS

53DV	67DV	70DV
8592	8595	8597
P8592	P8595	P8597

Model	Gas CAT.	Gas Type	Working Pressure	Aeration		Injector	Gas Rate m <sup>3</sup> /h	Input kW (Gross)		Country
								High	Low	
RIVA 53 DV	12H	Natural (G20)	20mbar	14mm x 16mm		530	0.648	6.8	3.25	GB, IE
RIVA 53 DV*	13+	Butane (G30)	29mbar	15 x 17	Open 1 side	200	0.180	6.3	3.25	GB, IE
		Propane (G31)	37mbar	BLANK			0.237			
RIVA 67 DV	12H	Natural (G20)	20mbar	15mm x 17mm		410	0.581	6.1	3.0	GB, IE
RIVA 67 DV*	13+	Butane (G30)	29mbar	14 x 16	Open 1 side	185	0.166	5.8	3.0	GB, IE
		Propane (G31)	37mbar	6 x 6			0.218			
RIVA 70 DV	12H	Natural (G20)	20mbar	16mm x 23mm		600	0.738	7.75	3.25	GB, IE
RIVA 70 DV*	13+	Butane (G30)	29mbar	16 x 23	Open 1 side	225	0.212	7.4	3.25	GB, IE
		Propane (G31)	37mbar	6 x 15			0.279			
*LPG models. The appliance is factory set to run on butane G30. If it is intended to be used on propane G31 the aeration plate supplied must be fitted. To change aeration plate refer to section replacing parts 9.						Efficiency RIVA 53DV & 67DV Class II - RIVA 70DV Class I				
						Flue Outlet Size 100 Ø / 152mm Ø				
						Gas Inlet Connection Size 8mm Ø				
<b>RESTRICTOR REQUIREMENT</b>										
<b>VERTICAL &amp; HORIZONTAL FLUE SPECIFICATION</b>										
Vertical flue height from top of appliance			Horizontal length				Restrictor size			
200mm x 500mm			Up to 500mm				No Restrictor			
500mm x 1000mm			Up to 1000mm				No Restrictor			
1000mm x 1490mm			Up to 1000mm				70mm Ø			
1500mm x 1990mm			Up to 5000mm				70mm Ø			
2000mm x 3000mm			Up to 5000mm				60mm Ø			
<b>TOP EXIT-VERTICAL ONLY INCLUDING OFFSET</b>										
Vertical flue height from top of appliance					Restrictor size					
3000mm x 4990mm					52mm Ø					
5000mm x 10000mm					47mm Ø					

# INSTALLATION INSTRUCTIONS

## TECHNICAL SPECIFICATION

This appliance has been certified for use in countries other than those stated. To install this appliance in these countries, it is essential to obtain the translated instructions and in some cases the appliance will require modification. Contact Gazco for further information.

### PACKING CHECKLIST

Qty	Description
1	Cassette and burner assembly
1	Decorative frame
1	Ceramic back panel *
1	Ceramic LH side panel *
1	Ceramic RH side panel *
1	Log set (7 logs)
1	Bag of vermiculite / Granules
1	Fixing kit containing:
1	Instruction manual
4	Woodscrews
4	Rawlplugs
1	Self adhesive foam strip
2	Frame retaining screws
*	Fitted in appliance

**NOTE:** All dimensions refer to the Riva 53DV, Riva 67DV & Riva 70DV when fitted with the Profil front.

Please refer to the separate Installation leaflet supplied with any alternative Gazco Riva front for applicable dimensions.

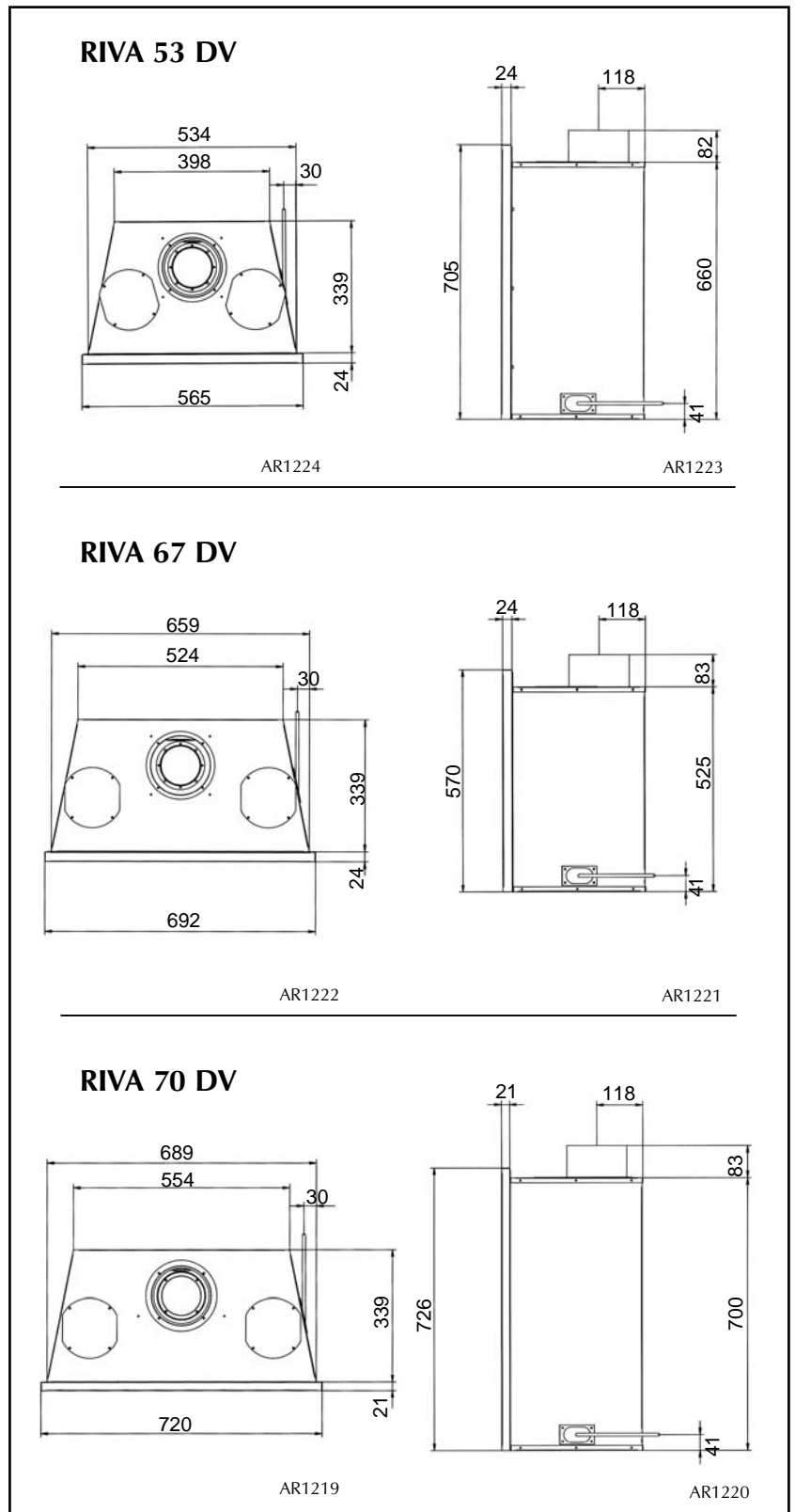

# INSTALLATION INSTRUCTIONS

## SITE REQUIREMENTS

### 1. FLUE AND CHIMNEY REQUIREMENTS

NOTE: This appliance can only be installed in conjunction with the flue supplied.

- 1.1 The flue must be sited in accordance with BS5440: Part 1 (latest edition). See diagram 1.
- 1.2 Any terminal which is less than 2 metres above any access (level ground, balcony or above a flat roof to which people have access) is to be fitted with a guard.
- 1.3 All vertical and horizontal flues must be securely fixed and fire precautions followed in accordance with local and national codes of practice.
- 1.4 A restrictor may be required. Refer to Technical Specifications on page 9.

- 1.5 Two types of flue terminals are available, horizontal and vertical. For a horizontal terminal, decide on the terminal position and measure the height from the top of the appliance to the centre of the required hole. For minimum and maximum flue dimensions see diagram 1A / 1B.
- 1.6 Access must be left either above or at the side of the installation to allow the flue to be assembled on top of the appliance. When a horizontal terminal is used, the vertical sections are assembled first, then the 90-degree elbow and finally the horizontal section including the terminal. If a masonry installation is to be built, a suitable lintel must be used to support the opening.
- 1.7 Only the horizontal terminal section can be reduced in size.

1

Dimension	Terminal position	Minimum Distance
A*	Directly below an opening, air brick, opening windows, etc.	600mm
B*	Above an opening, air brick opening windows, etc.	300mm
C*	Horizontally to an opening, air brick opening windows etc.	400mm
D	Below gutters, soil pipes or drain pipe	300mm
E	Below eaves	300mm
F	Below balconies or car port roof	600mm
G	From a vertical drain pipe or soil pipe	300mm
H	From an internal or external corner	600mm
I	Above group roof or balcony level	300mm
J	From a surface facing the terminal (also see 6.1.2)	600mm
K	From a terminal facing the terminal	600mm
L	From an opening in the car port (e.g. door, window) into the dwelling	1200mm
M	Vertically from a terminal on the same wall	1500mm
N	Horizontally from a terminal on the same wall	300mm
O	From the wall on which the terminal is mounted	N/A
P	From a vertical structure on the roof	600mm
Q	Above intersection with roof	300mm

\* In addition, the terminal should not be nearer than 300mm to an opening in the building fabric formed for the purpose of accommodating a built-in element such as a window frame

AR0602

# INSTALLATION INSTRUCTIONS

## SITE REQUIREMENTS

### 2. FLUE OPTIONS

#### RIVA 53, 67 AND 70 ONLY

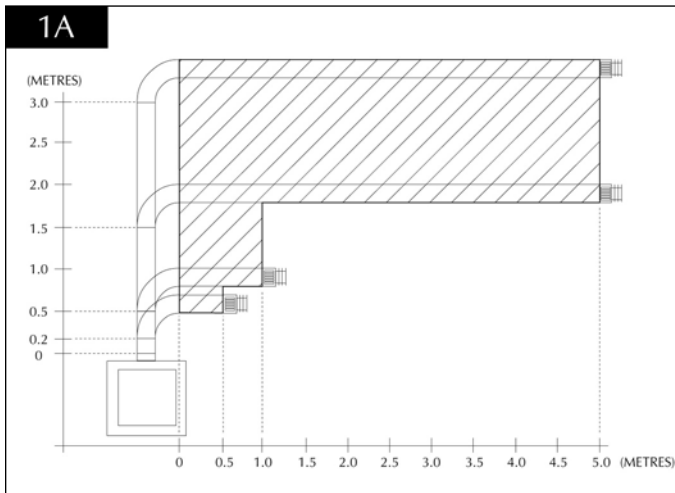

Start of bend to centreline of horizontal flue 170mm.  
Centreline of vertical flue to end of bend 220mm.

#### RIVA 53, 67 AND 70 ONLY

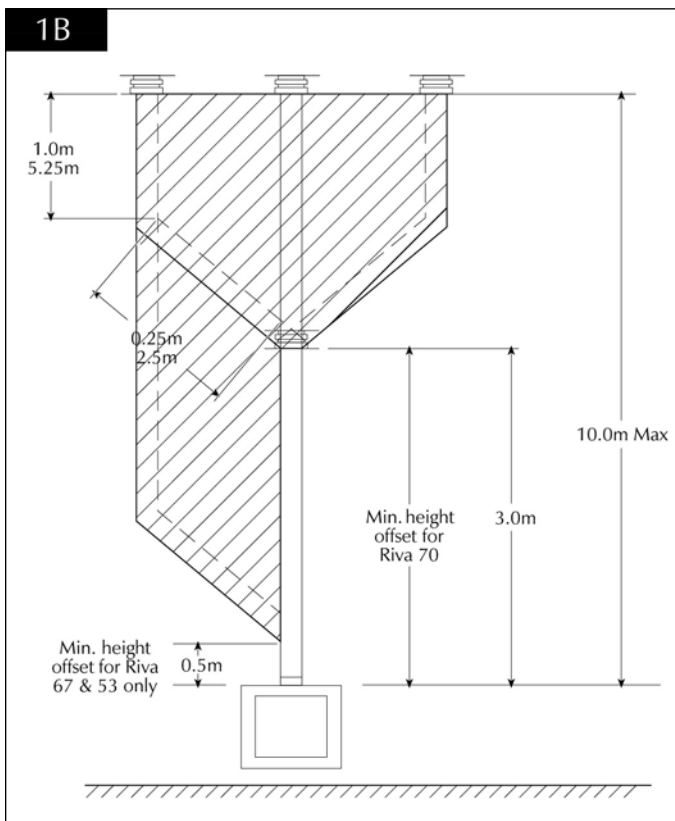

#### 2.1 TOP FLUE UP & OUT KIT (8534) - Riva 53, 67 and 70 only

Vertical from the top of the appliance then horizontally out. (See Diagram 1A)

The basic kit comprises:

- 1 x 200mm vertical length
- 1 x 500mm terminal length (cut to length on site)
- 1 x 90 degree elbow
- 1 x wall plate
- 1 x 70mm restrictor
- 1 x 60mm restrictor fixing screws

The kit may be used on its own. (Note - with a 200mm rise only the 500mm terminal length can be used). Extra lengths may be added to the vertical and horizontal from the list below.

#### 2.2 TOP FLUE VERTICAL KIT (8524) - Riva 53, 67 and Riva 70

Vertical from the top of the appliance (See Diagram 1B)

A minimum vertical rise 3m (9'10") to a maximum of 10m (32'10")

The basic kit comprises:

- 2 x 1m lengths
- 1 x 1m terminal length
- 1 x 52mm restrictor
- 1 x 47mm restrictor

Extra lengths may be added from the list below.

#### 2.3 TOP FLUE VERTICAL OFFSET KIT (8530) - Riva 53, 67 and Riva 70

Used with kit 8524 only.

A minimum rise of 500mm (19 1/2") is required to the first bend on Riva 53 & 67 and 3m (9'10") to the first bend on the Riva 70.

#### 2.4 EXTRA FLUE LENGTHS

All flue components are 150mm diameter (6")

- 8527 200mm nominal (140mm actual)
- 8528 500mm nominal (440mm actual)
- 8529 1000mm nominal (940mm actual)

#### 2.5 If a vertical only flue system has been purchased refer to diagram for minimum and maximum options. The following areas need careful consideration.

- a) Terminal positions
- b) Flue supports
- c) Weatherproofing
- d) Fire precautions

For all the above, local and national codes of practice must be adhered to.

# INSTALLATION INSTRUCTIONS

## SITE REQUIREMENTS

### 3. GAS SUPPLY

- 3.1 Before installation, ensure that the local distribution conditions (identification of the type of gas and pressure) and the adjustment of the appliance are compatible.
- 3.2 Ensure that the gas supply is capable of delivering the required amount of gas and is in accordance with the rules in force.
- 3.3 Soft copper tubing can be used to install the appliance. Soft soldered joints can be used externally of the appliance but must be restricted to the area shown in diagram 2.

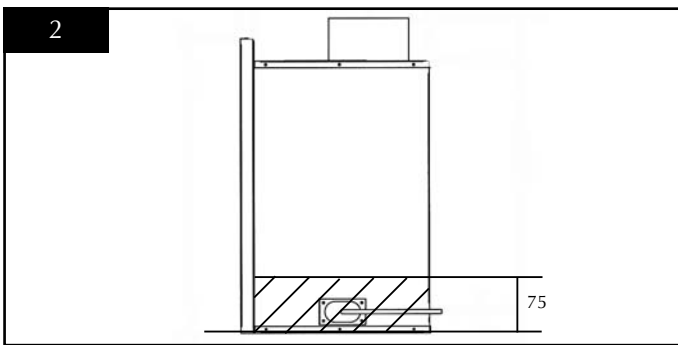

- 3.4 This appliance is supplied complete with a factory fitted isolation device incorporated into the inlet connection, no further isolation device is required.
- 3.5 All supply gas pipes must be purged of any debris that may have entered, prior to connection to the appliance.
- 3.6 The gas supply enters through the silicone panel located on the RH side of the outer box; this will need to be slit with a sharp knife prior to passing the supply pipe through.

### 4. VENTILATION

- 4.1 This appliance requires no additional ventilation.

### 5. APPLIANCE LOCATION

- 5.1 This appliance must stand on a non-combustible hearth that is at least 12mm thick; the minimum opening dimensions are shown in diagram 2A.

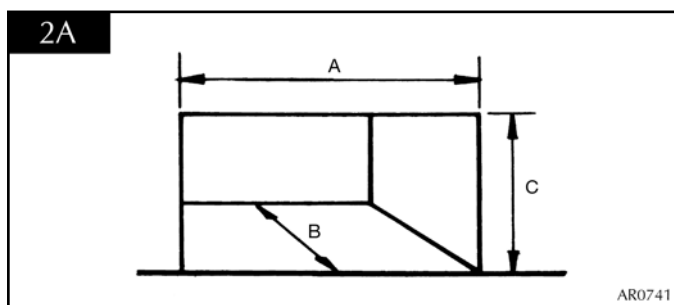

DIMENSION	RIVA 53 DV	RIVA 67 DV	RIVA 70 DV
A	540mm	668mm	700mm
B	350mm	350mm	350mm
C	665mm	530mm	705mm

- 5.2 This appliance can be installed on an external wall or with a roof terminal.
- 5.3 This appliance is not suitable for installation onto a combustible wall; all combustible materials must be removed from the area shown in diagrams 2B, 2C and 2D.

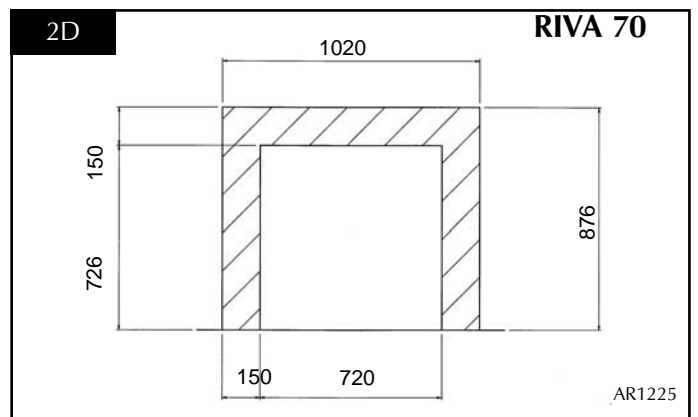
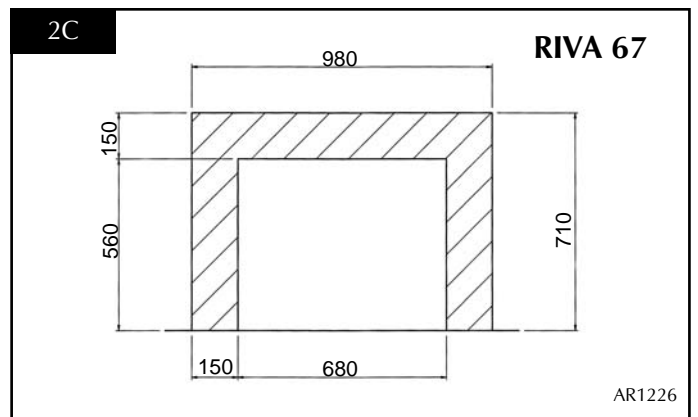
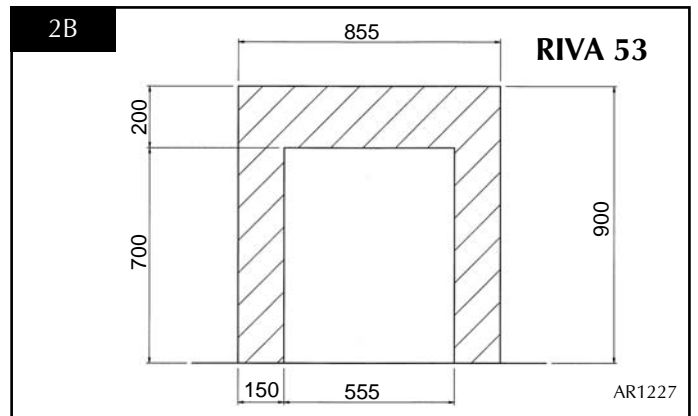

# INSTALLATION INSTRUCTIONS

## SITE REQUIREMENTS

### STUDWORK INSTALLATION

- 5.4 Combustible parts of the studwork must not be any closer than the minimum dimensions shown in diagrams 3a,b & c. These dimensions need to be maintained even if the framework is protected by non-combustible material.

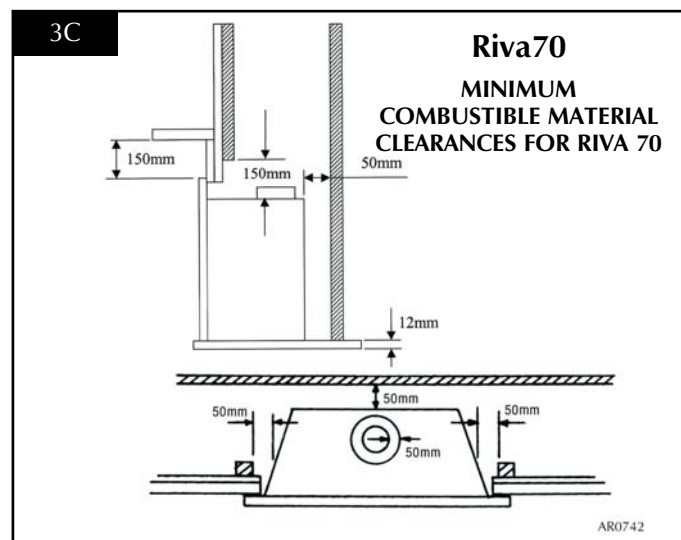
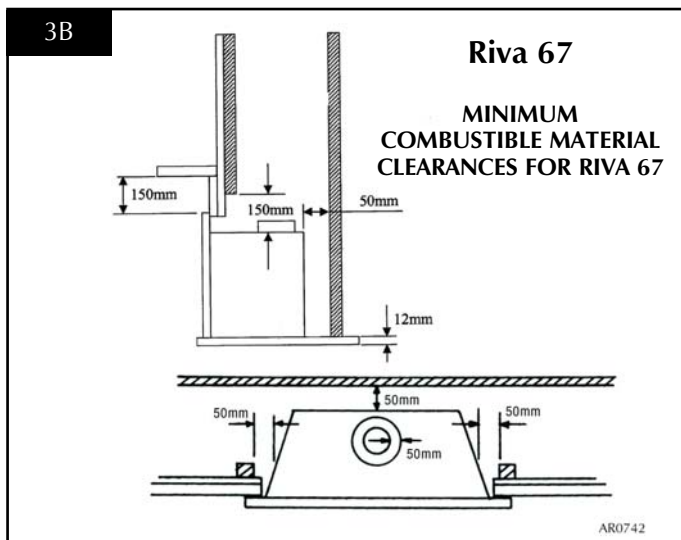
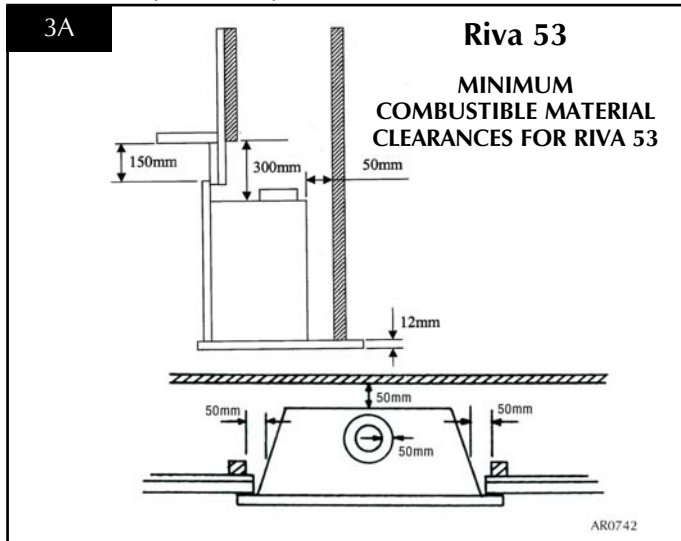

- 5.4.1 Do not pack the void around or above the appliance with insulation materials such as mineral wool.
- 5.4.2 The void into which the cassette is fitted must be ventilated to prevent a build up of heat. If the void is sealed then it will be necessary to fit vents at both low and high levels of approximately 50cm<sup>2</sup> each. These vents should take cold air from the room and return warm air back into the room.
- 5.4.3 A removable access hatch must be left in the side of the chimney breast for future servicing and inspection of the appliance.
- 5.4.4 Build the studwork chimney breast to the desired size. **Ensure that the clearances to combustibile materials is maintained**, decide upon and cut the hole for the flue exit - see section 17. It is recommended to line the aperture for the cassette with 12mm thick non-combustible material as shown. Provide gas and electric services (if required) into the enclosure. See diagram 4

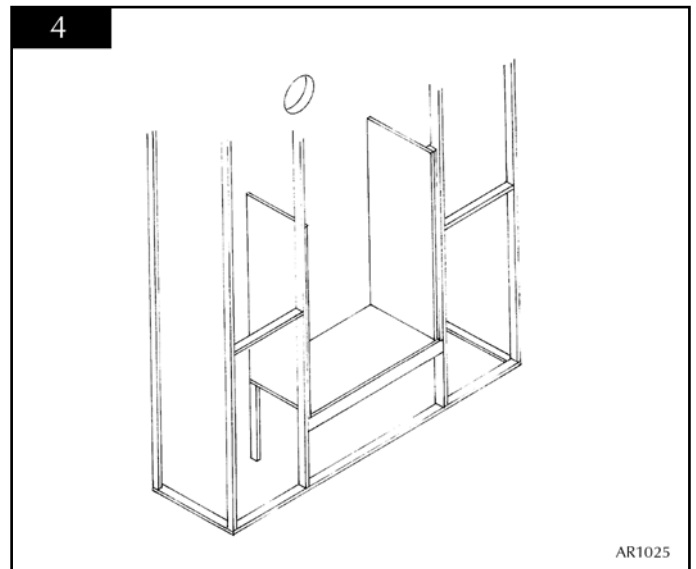

- 5.4.5 Place the cassette into position and fit a non-combustible panel above the cassette as shown. See diagram 5. Ensure the void is adequately ventilated.

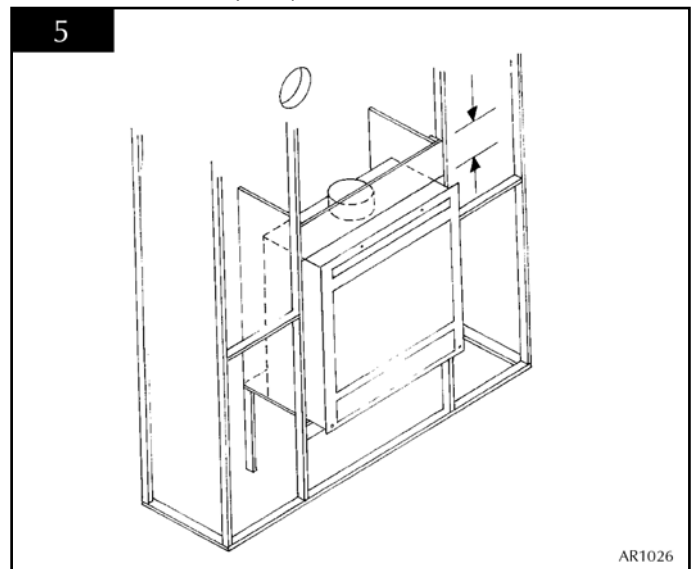

# INSTALLATION INSTRUCTIONS

## SITE REQUIREMENTS

5.4.6 With the cassette forward of its final position apply plasterboard to the front of the chimney breast and apply plaster finish. In order to prevent possible plaster cracks, it is recommended to cover the face of the wall immediately above the cassette with non-combustible material such as marble or granite. See diagram 6.

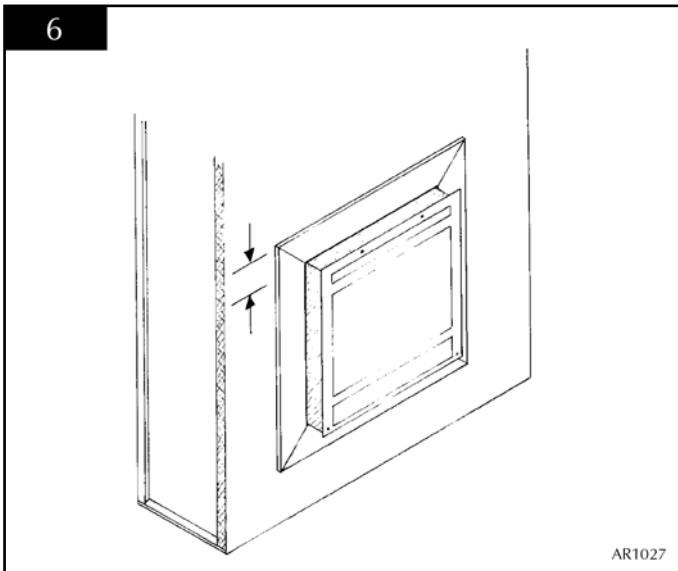

5.4.7 Push the cassette back into its final position and connect the flue system, gas and electric services using the openings in the side of the chimney breast for access. Following commissioning complete the sides of the chimney breast. See diagram 7.

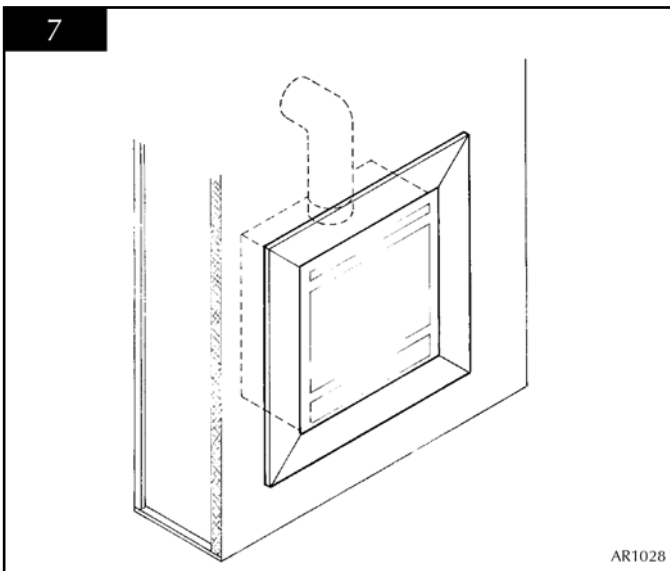

5.4.8 A removable access hatch must be left in the side of the chimney breast for future servicing and inspection of the appliance.

### 5.5 MASONRY INSTALLATION

5.5.1 If it is necessary to install this appliance into a non-combustible e.g. masonry or brickwork, minimal clearances are required, however due to the flue spigot protruding from the top of the appliance, the following method is recommended.

5.5.2 Mark out the following:

- A. Cassette position
- B. Extra room below the cassette
- C. Lintel position
- D. Flue installation access

NOTE: The position of the flue installation access will depend on the route and length of flue to be installed. A hole will be required to gain access to each joint and the exit through the wall. These holes are ideally in the side of the chimney breast. See diagram 8.

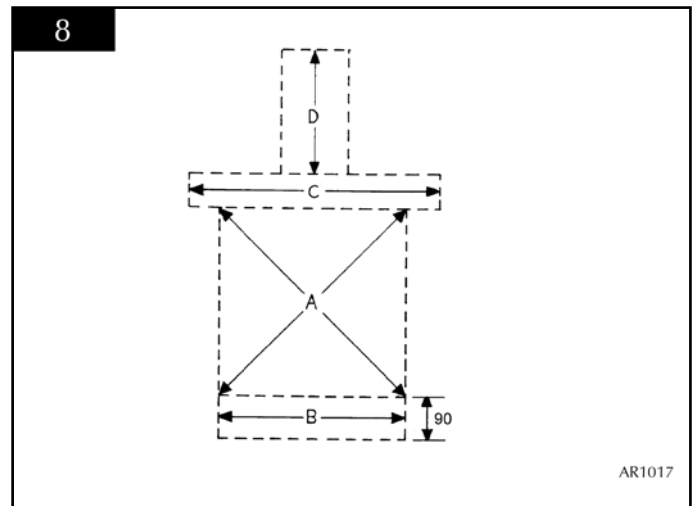

5.5.3 Cut out all holes and fit lintel. See diagram 9.

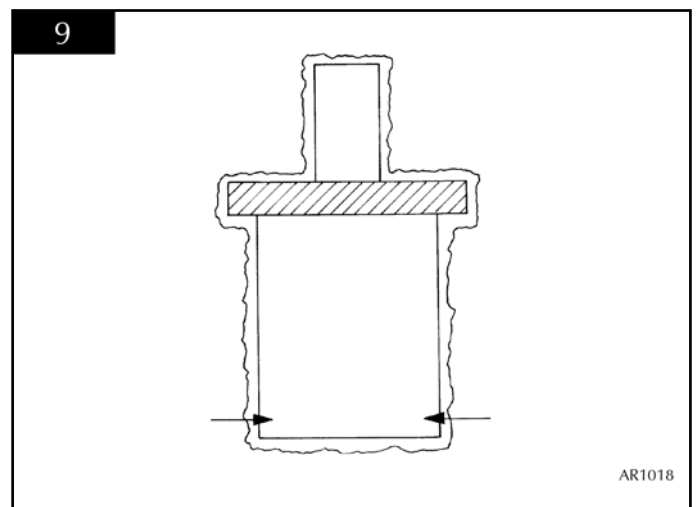

# INSTALLATION INSTRUCTIONS

## SITE REQUIREMENTS

5.5.4 Apply plaster finishing around the aperture that the cassette will fit into. See diagram 10.

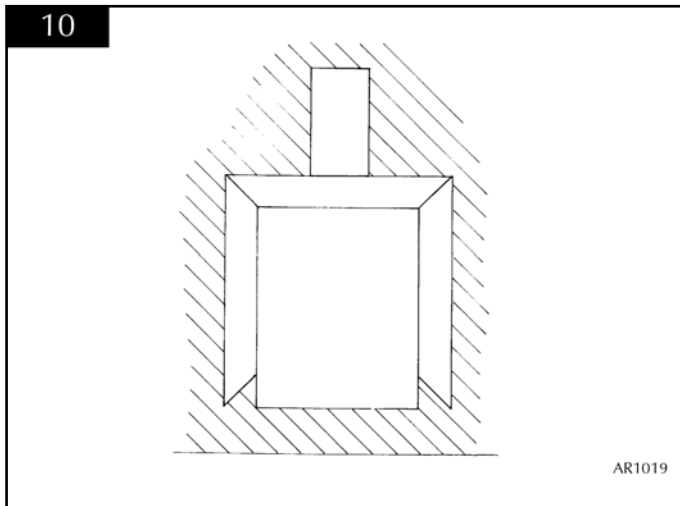

NOTE: In order to prevent possible plaster cracks, it is recommended to cover the immediate area above the cassette with non-combustible material such as marble or granite.

5.5.5 Place the cassette into the opening. See diagram 11.

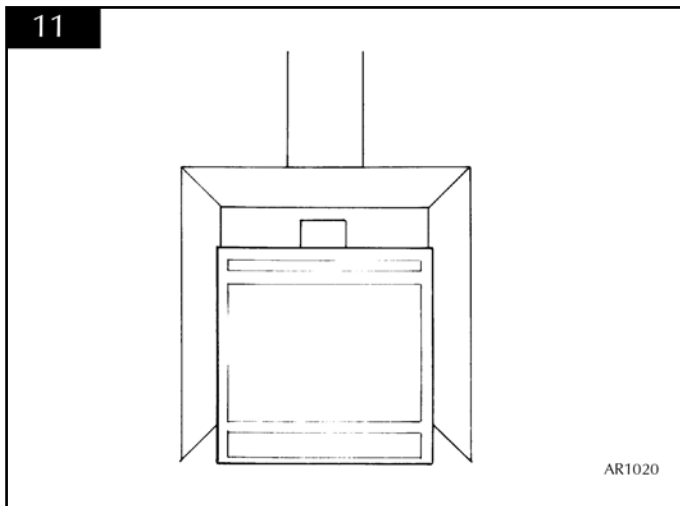

5.5.6 Raise the cassette into its final position and support it on 12mm thick non-combustible material. See diagram 12.

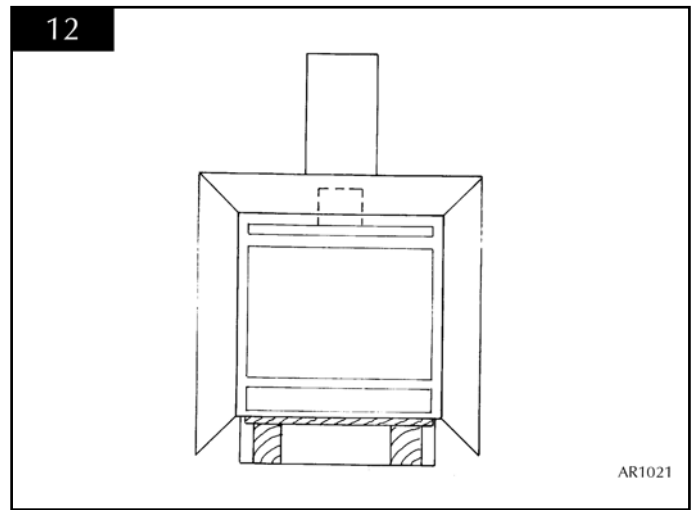

5.5.7 Connect the flue system through the access holes. See diagram 13.

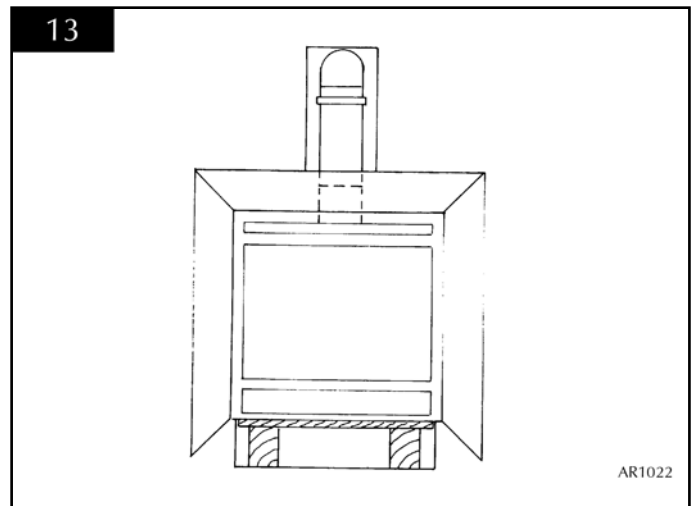

5.5.8 After fully commissioning the appliance, make good all of the access holes. See diagram 14.

NOTE: It is recommended to cover some of these access holes with removable panels to assist in future servicing. See diagram 14.

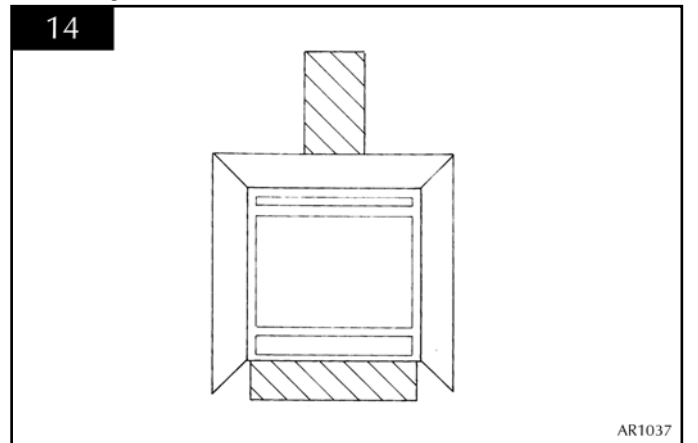



# INSTALLATION INSTRUCTIONS

## INSTALLATION

**IMPORTANT:** ENSURE THAT THE APPLIANCE IS CORRECTLY ADJUSTED FOR THE GAS TYPE AND CATEGORY APPLICABLE IN THE COUNTRY OF USE. REFER TO DATA BADGE AND TECHNICAL SPECIFICATIONS AT THE FRONT OF THE BOOKLET.

LPG MODELS: THE APPLIANCE IS FACTORY SET TO RUN ON BUTANE (G30). IF IT IS INTENDED TO BE USED ON PROPANE (G31) THE AERATION PLATE SUPPLIED MUST BE FITTED.

TO CHANGE AERATION PLATE REFER TO SECTION 28.

FOR DETAILS OF CHANGING BETWEEN GAS TYPES REFER TO SECTION 29.

### 1. CONTROL UPGRADE

- 1.1 This appliance is fitted with a control valve that can be easily upgraded to battery powered remote control. There are two versions of this control which can be obtained through your local Gazco stockist.
- 1.2 This upgrade can be fitted before or after installation but if side clearances are limited then it will be easier to upgrade the stove before installation. Full instructions are included with the kit.
- 1.3 **STANDARD REMOTE CONTROL** This remote control can control the gas appliance after the pilot has been lit. It can turn the main burner on and regulate it from low through to high and back again. It can turn the main burner off leaving the pilot burning. GAZCO PART NUMBER 8455.
- 1.4 **THERMOSTATIC AND TIMER REMOTE CONTROL** This remote control can control the gas appliance after the pilot has been lit. In 'MANUAL MODE' it can be used to turn the main burner on and manually regulate it from low through to high and back again. It can also be used to turn the main burner off leaving the pilot burning. In 'AUTO MODE' it will automatically regulate the room temperature. In 'TIMER MODE' it will turn the fire on and off according to a pre-set programme and automatically regulate the room temperature during two on periods. GAZCO PART NUMBER 8456

### 2. SAFETY PRECAUTIONS

- 2.1 This appliance must be installed in accordance with the rules in force, and used only in a sufficiently ventilated space. Please read these instructions before installation and use of this appliance.
- 2.2 These instructions must be left intact with the user.
- 2.3 Do not attempt to burn rubbish on this appliance.
- 2.4 In your own interest, and those of safety, this appliance must be installed by competent persons in accordance with local and national codes of practice. Failure to install the appliance correctly could lead to prosecution.
- 2.5 Keep all plastic bags away from young children.

- 2.6 Do not place any object on or near to the appliance. Allow adequate clearance above the appliance.

IF THE APPLIANCE IS EXTINGUISHED OR GOES OUT IN USE, WAIT 3 MINUTES BEFORE ATTEMPTING TO RELIGHT THE APPLIANCE.

### 3. INSTALLATION OF THE APPLIANCE

**NOTE:** THERE IS AN OPTIONAL CONVECTION FAN KIT AVAILABLE CODE No. 8576(53) AND 8571(67 & 70). THIS CAN BE FITTED EITHER DURING OR AFTER INSTALLATION, BUT PROVISION FOR A POWER SUPPLY MUST BE MADE PRIOR TO INSTALLATION OF THE APPLIANCE. ALSO THERE IS A DUCT KIT, CODE No. 8572 WHICH MUST BE INSTALLED AT THE SAME TIME AS THE APPLIANCE INSTALLATION.

- 3.1 Remove the appliance from the carton and discard all unnecessary packaging. Ensure no components are thrown away when unpacking.
- 3.2 If you have purchased a Profil decorative front, this will be located inside the cardboard fitment situated in front of the Riva cassette, remove from packing and place to one side until required.
- 3.3 Remove the glass door by unscrewing the nine retaining screws. See diagram 1. Carefully remove the box containing the logs from the firebox. Place to one side as these are fragile. The ceramic brick effect is factory fitted, take care not to damage these components.

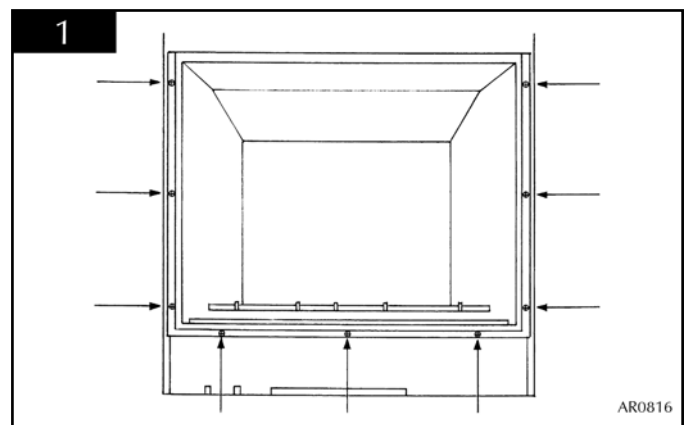

- 3.4 The gas supply enters through the silicone panel located on the RH side of the outer box; this will need to be slit with a sharp knife prior to passing the supply pipe through.
- 3.5 Two types of flue terminals are available, horizontal and vertical. For a horizontal terminal, decide on the terminal position and measure the height from the top of the appliance to the centre of the required hole. For minimum and maximum flue dimensions see diagram 2.

# INSTALLATION INSTRUCTIONS

## INSTALLATION

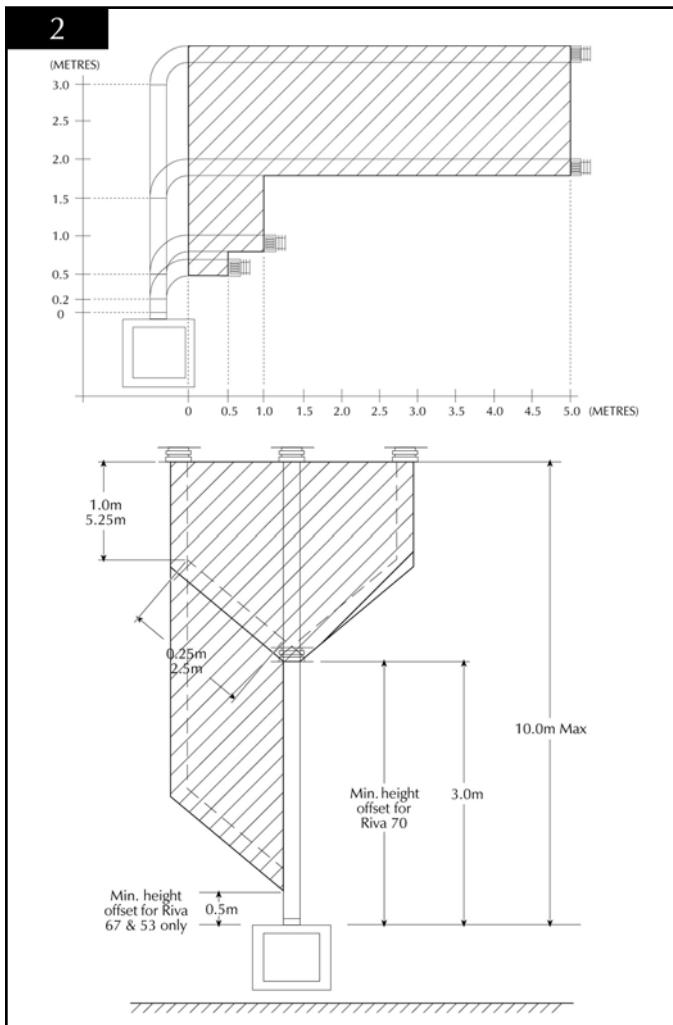

**TAKE CARE WHEN MARKING OUT FOR THE FLUE AS IT IS DIFFICULT TO MOVE AFTER INSTALLATION. IF A RESTRICTOR IS REQUIRED FIT THIS BETWEEN THE SMALL OUTLET SPIGOT AND THE AIRDUCT SEE DIAGRAM 3. REFER TO TECHNICAL SPECIFICATIONS FOR RESTRICTOR SIZE.**

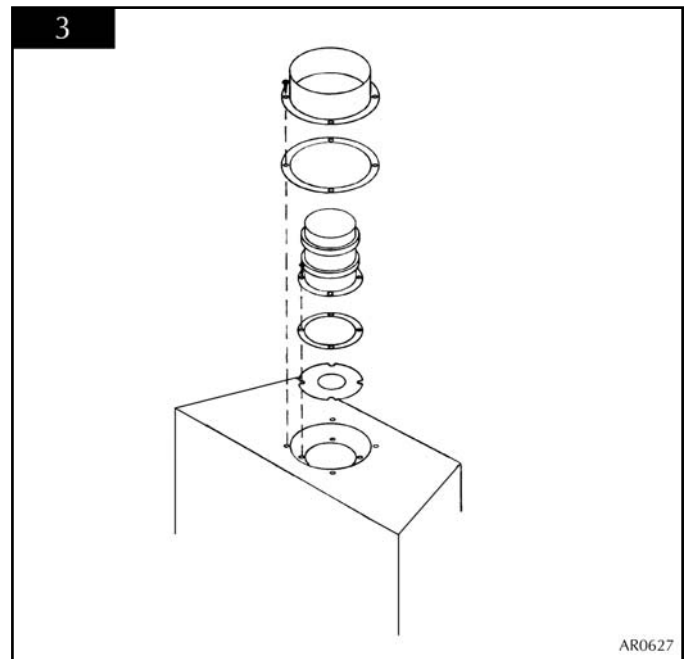

- 3.6 A 152mm (6") diameter hole is required to install the flue. This can be achieved by either:
- Core drill
  - Hammer and chisel.
- It is advisable to drill small holes around the circumference when using method b. Make good both ends of the hole.
- 3.7 Remove the backing paper from the silicone foam strip supplied in the fixing kit and fix to the back of the outer flanges of the appliance, ensure that it is located below the frame location lugs on the top flange. Foam strip may need cutting to length.
- 3.8 **When installing the appliance into a combustible enclosure, ensure all the clearances are observed. It is advisable to use a marble slip or similar material between the appliance and the plasterboard. See diagram 3A, 3B and 3C in site requirements.**

RESTRICTOR REQUIREMENT		
VERTICAL & HORIZONTAL FLUE SPECIFICATION		
Vertical flue height from top of appliance	Horizontal length	Restrictor size
200mm x 500mm	Up to 500mm	No Restrictor
500mm x 1000mm	Up to 1000mm	No Restrictor
1000mm x 1490mm	Up to 1000mm	70mm Ø
1500mm x 1990mm	Up to 5000mm	70mm Ø
2000mm x 3000mm	Up to 5000mm	60mm Ø
TOP EXIT-VERTICAL ONLY INCLUDING OFFSET		
Vertical flue height from top of appliance	Restrictor size	
3000mm x 4990mm	52mm Ø	
5000mm x 10000mm	47mm Ø	

# INSTALLATION INSTRUCTIONS

## INSTALLATION

Secure the appliance through the four fixing holes using the screws provided. See diagram 5.

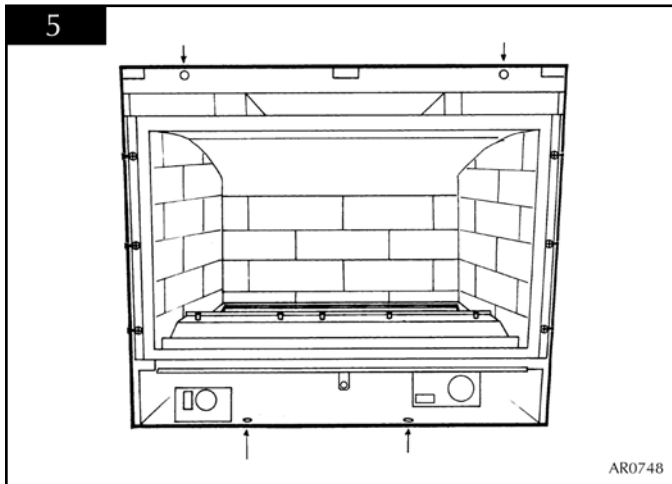

3.9 Access must be left either above or at the side of the installation to allow the flue to be assembled on top of the appliance. When a horizontal terminal is used, the vertical sections are assembled first, then the 90-degree elbow and finally the horizontal section including the terminal. If a masonry installation is to be built, a suitable lintel must be used to support the opening.

3.10 Only the horizontal terminal section can be reduced in size. To determine the length, measure from the outside of the wall to the stop on the 90-degree elbow. Measuring from the slots on the outer flue furthest away from the outlet, add 10mm onto the required measured length and mark around the flue. See diagram 6.

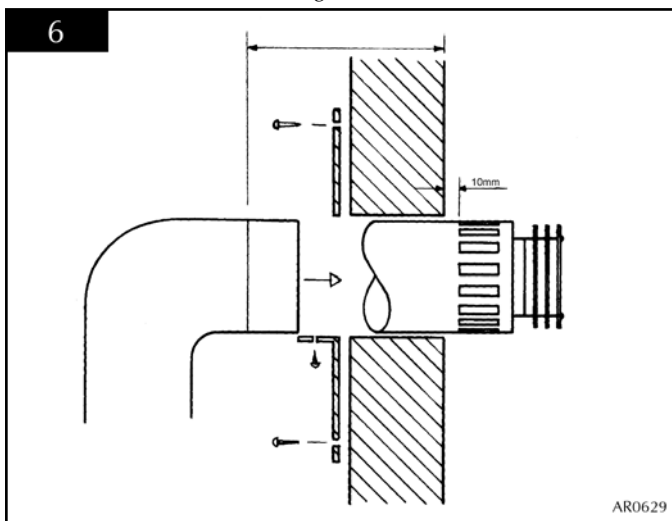

A wall plate is supplied to secure the flue to the wall. Bend the tab to 90°. Assemble the plate onto the flue but only secure to the wall and flue when the flue is fully assembled. See diagram 6.

3.11 There is a cardboard fitment in the terminal. This is to support the flue whilst it is cut to length. **REMOVE THE REMAINDER OF THE CARDBOARD AFTER CUTTING TO SIZE.** See diagram 7.

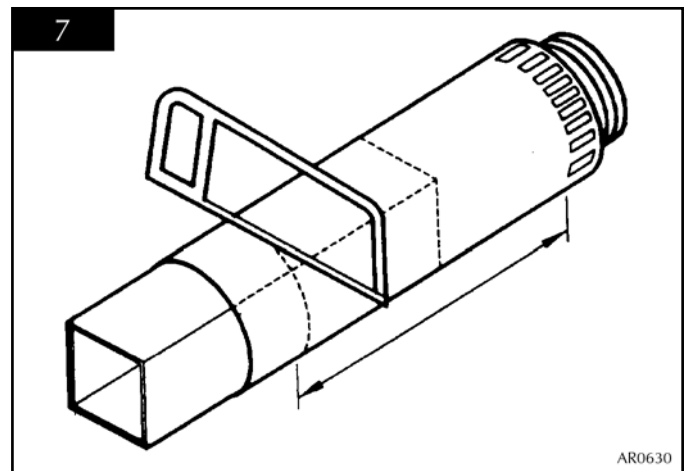

3.12 Remove the compression elbow from the appliance and connect it to the gas supply pipe. As the appliance is located into the enclosure, pass the elbow and supply pipe through the silicone panel on the RH side. **PURGE THE SUPPLY PIPE.** This is essential to expel any debris that may block the gas controls. Connect the elbow to the appliance inlet pipe. See diagram 8.

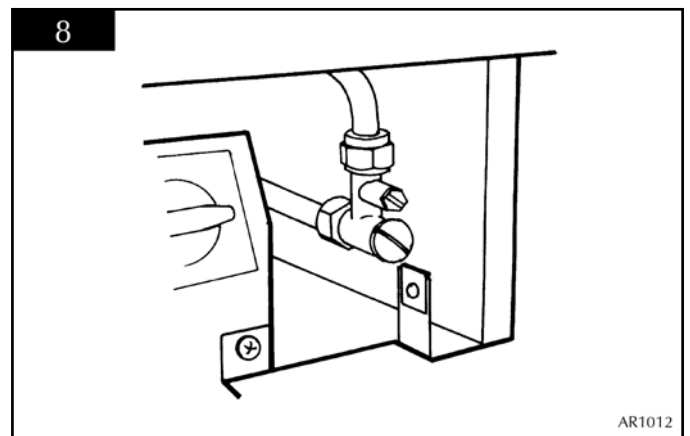

3.13 Connect a suitable pressure gauge to the test point located on the inlet fitting and turn the gas supply on. Light the appliance and check for leaks. Turn the appliance to maximum and check that the supply pressure is as stated on the databadge. Turn the gas off and replace the test point screw, turn the gas on and check the test point for leaks.

# INSTALLATION INSTRUCTIONS

## INSTALLATION

### 4. ARRANGEMENT OF FUEL BED COMPONENTS

#### RIVA 67DV & 70 DV

THE BAG OF VERMICULITE CONTAINED IN THE LOG SET IS TO SIMULATE AN ASH EFFECT. THIS IS NOT TO BE PLACED ON THE BURNER.

- 4.1 Fill the front compartment where the log location studs are attached. The vermiculite must only reach the top of the front and rear flanges. Place vermiculite around the rear and sides of the burner tray. **ENSURE NO VERMICULITE FALLS ON THE BURNER.** See diagram 9.

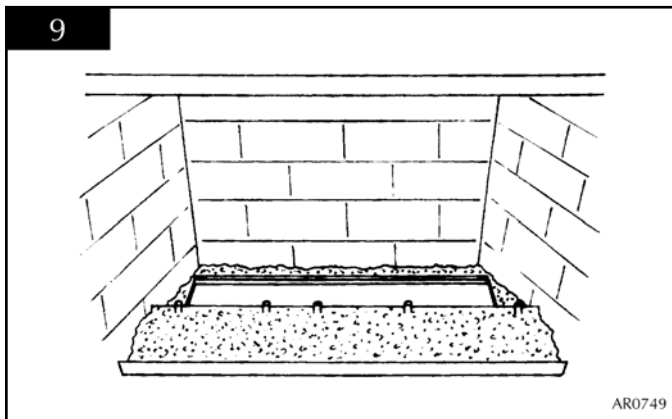

- 4.2 Place log 1 (large black log) on the burner. Ensure the rear of the log touches the rear of the burner. See diagram 10.

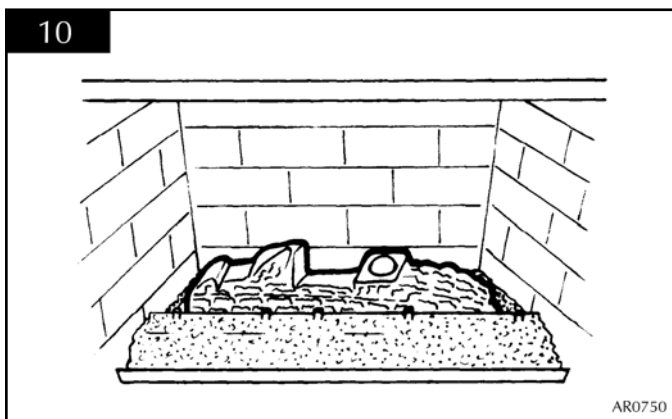

**CENTRALISE THE LOG BETWEEN THE BURNER PORTS AT EITHER END.**

**ALL THE REMAINING LOGS EXCEPT FOR THE SMALLEST ONE HAVE LOCATION HOLES ON THE UNDERSIDE, THESE LOCATE ON THE STUDS AT THE FRONT OF THE FIRE.**

- 4.3 Place log 2 on the centre and locate the rear of the log on the large flat area of log 1. See diagram 11.

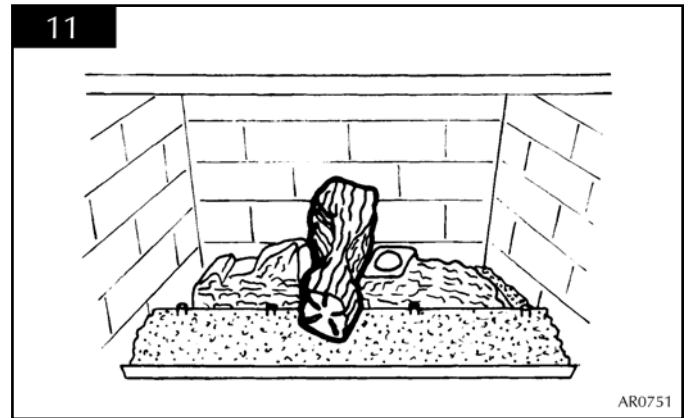

- 4.4 Place log 3 on the far left-hand stud. The recess on the underside of the log should locate on the top of log 1 on the far left-hand side. See diagram 12.

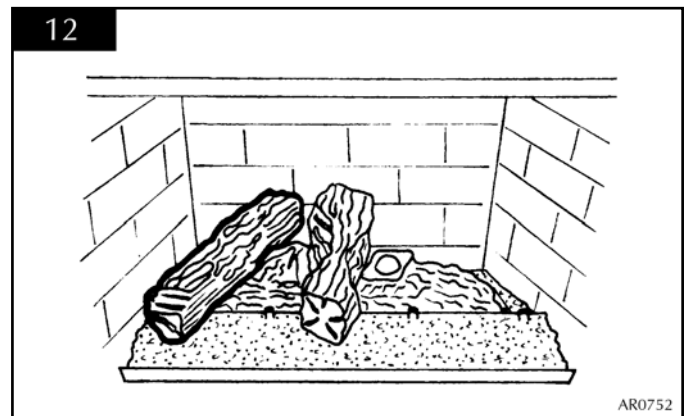

- 4.5 Place log 4 on the right hand side of the centre log. There is a large recess on the underside of the log, which locates on log 1. See diagram 13.

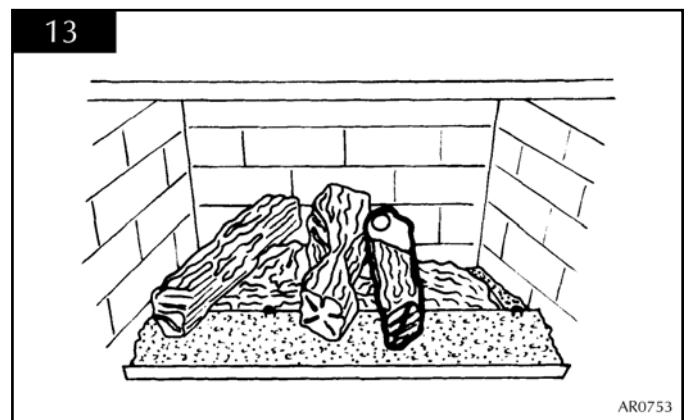

# INSTALLATION INSTRUCTIONS

## INSTALLATION

- 4.6 Place log 5 on top of log 4 and ensure the two large locations engage. Locate the front of the log on to the far right hand stud. See diagram 14.

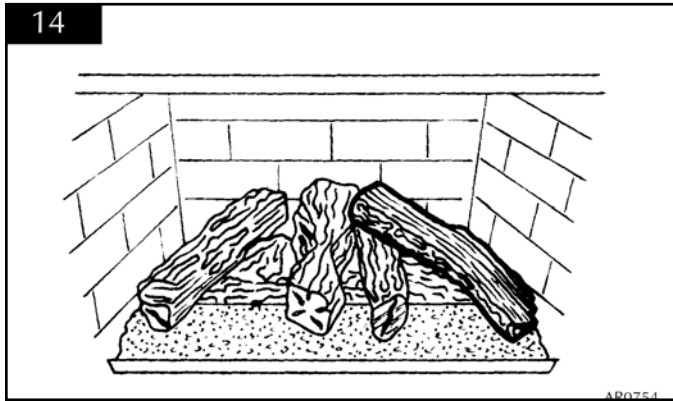

- 4.7 Place log 6 on the remaining stud and lean the log on to log 1 between logs 2 and 3. There is a notch to locate the log. See diagram 15.

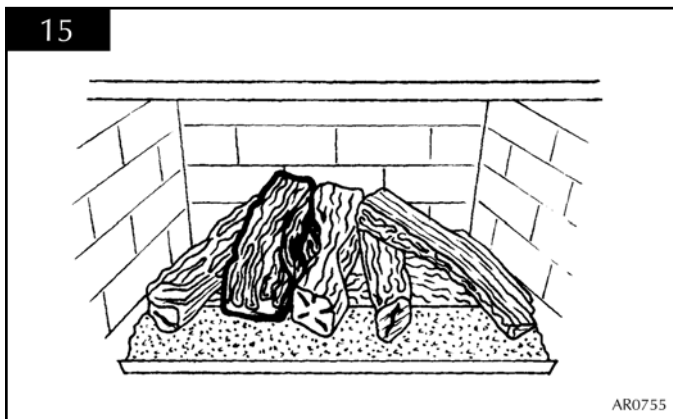

- 4.8 Place log 7 on the vermiculite at the front of the fire between logs 4 and 5. **DO NOT PLACE THIS LOG ON THE BURNER. IT IS ONLY TO FILL THE GAP BETWEEN LOGS 4 AND 5.** The charred effect should face the rear of the fire. See diagram 16.

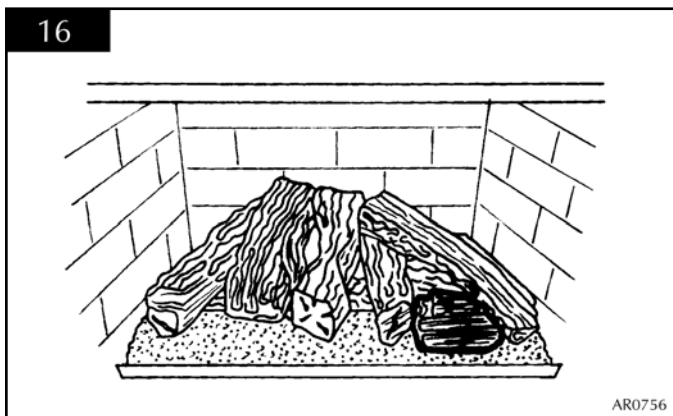

### RIVA 53DV

- 4.9 Place log A on to the burner. Ensure the rear of the log touches the rear of the burner. See diagram 17.

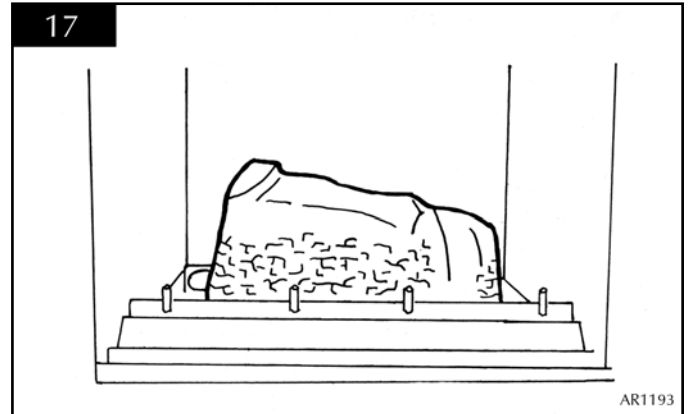

**CENTRALISE THE LOG BETWEEN THE BURNERPORTS AT EITHER END.**

Four of the remaining logs have location holes on the underside. These locate on the studs at the front of the fire.

- 4.10 Place log D on the third stud from the left and resting at the rear on log A. See diagram 18.

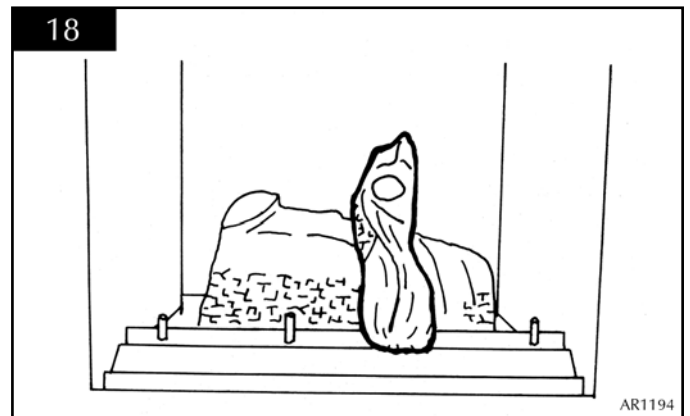

- 4.11 Place log C on the second stud and resting at the rear on log A. See diagram 19.

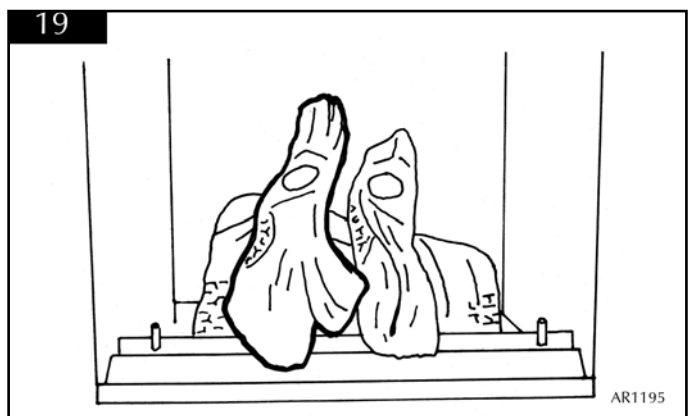

# INSTALLATION INSTRUCTIONS

## INSTALLATION

- 4.12 Place log B on the first stud. The recess on the underside of the log should locate on to the top of log C. See diagram 20.

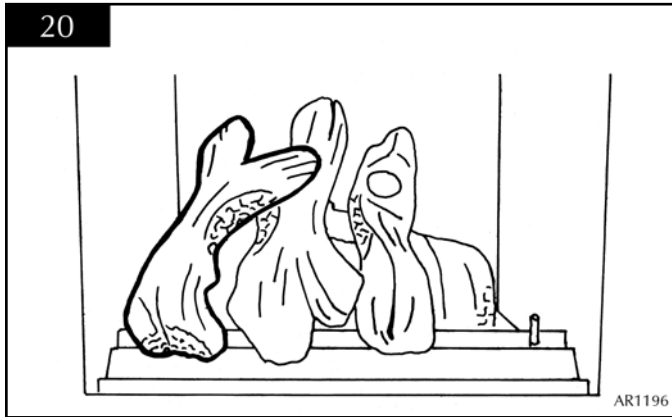

- 4.13 Place log E on to the last stud. The recess on the underside of the log should locate on to the top of log D. See diagram 21.

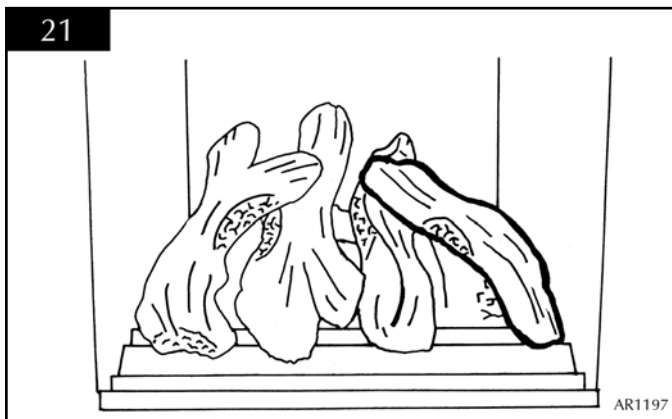

- 4.14 Place log F resting on the rear tray and leaning forward to locate in the recess in log E. See diagram 22.

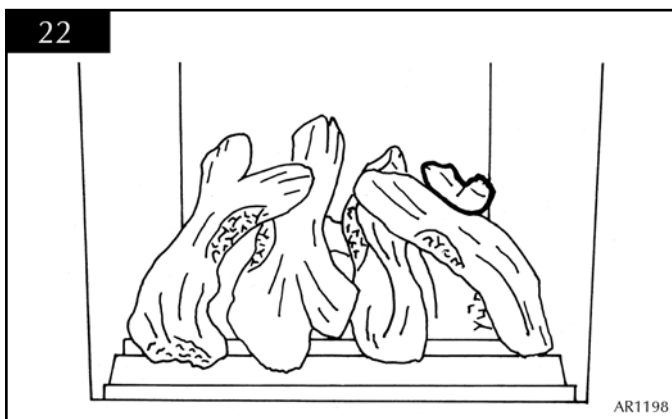

- 4.15 Place log G at the front of the fire between logs D and E. DO NOT PLACE THIS LOG ON THE BURNER. IT IS ONLY TO FILL THE GAP BETWEEN LOGS D AND E. The charred effect should face the rear of the fire. See diagram 23.

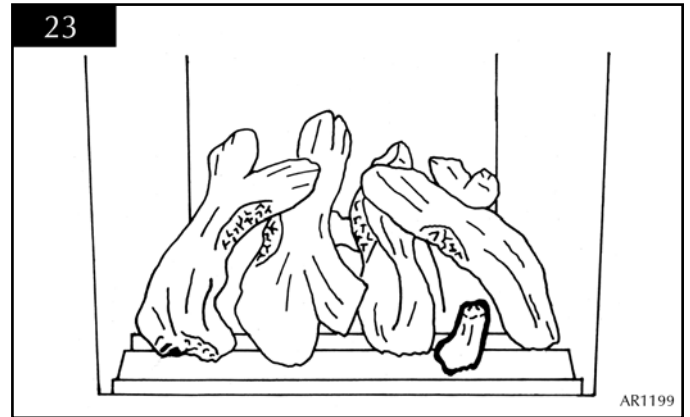

- 4.16 With the granules fill the front compartment around the logs evenly. ENSURE NO GRANULES FALL ON THE BURNER. See diagram 24.

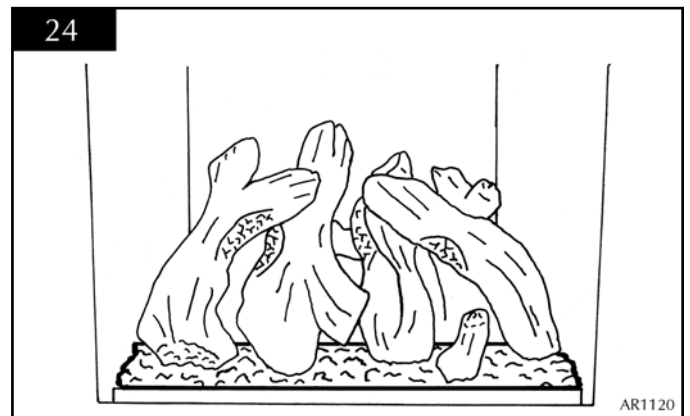

### 5. FITTING THE DOOR

- 5.1 Ensure that the fibreglass seal on the back of the glass frame is intact then hook the location tabs over the hooks on the top of the firebox. Replace the nine screws working from the top down. Tighten the screws evenly. DO NOT OVER TIGHTEN. See diagram 2, Section 5 'Cleaning the Riva'. NEVER OPERATE THE APPLIANCE WHEN THE GLASS PANEL IS REMOVED OR BROKEN.
- 5.2 Replace the decorative frame by hooking the top over the location lugs on top of the flanges, replace the two fixing screws, see diagram 1, Section 5 'Cleaning the Riva'.
- NOTE: If the appliance is fitted with an alternative Gazco Riva front, please refer to the separate leaflet supplied with the front.
- NOTE: ENSURE THAT THE LOGS ARE POSITIONED AS ABOVE. ONLY USE THE CORRECT AMOUNT OF LOGS AS SPECIFIED IN THE DIAGRAMS.

# INSTALLATION INSTRUCTIONS

## INSTALLATION

### 6. LIGHTING THE RIVA

- 6.1 Locate the control valve on the appliance. There are two control knobs on the valve, the right hand knob controls the pilot ignition and the left hand knob controls the main burner.

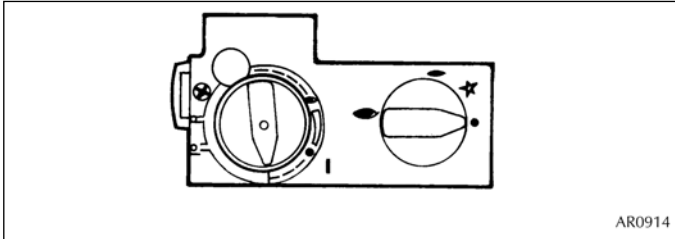

- 6.2 If your appliance has already been upgraded to battery remote control, please refer to the instructions provided with the upgrade to operate the remote control. The following instructions will work for either situation.
- 6.3 Ensure that the left hand control knob is pointing to off (●).
- 6.4 Ensure that the right hand control knob is pointing to off (●).
- 6.5 Press in the right hand control knob and rotate it anti-clockwise until a click is heard (keep pressing in) and the knob is pointing to pilot (☛). The pilot should now light. If the pilot has not lit, repeat the procedure until it does.
- 6.6 Keep the control knob pressed for 10 seconds and then release it, the pilot should stay alight. If the pilot goes out, repeat the procedures until it does.
- 6.7 If the pilot will not light after repeated attempts, contact the retailer or installer from whom the appliance was purchased.
- 6.8 Turn the right hand control to point to main burner (☞). The appliance can now be controlled using the left hand control knob.
- 6.9 Turn the left hand control knob to point to low fire (☞), the main burner will light on low. The burner can now be controlled between low and high settings. Turn the control knob anticlockwise to increase the flame height and clockwise to decrease the flame height.

**THE YELLOW FLAMES WILL APPEAR WHEN THE FIRE HAS GAINED SUFFICIENT HEAT - TYPICALLY 10 TO 20 MINUTES.**

### 7. COMMISSIONING

- 7.1 Check all ceramics, door etc.
- 7.2 Check flame picture.
- 7.3 Check gas pressure.

# SERVICING INSTRUCTIONS

## SERVICING / FAULT FINDING CHARTS

### 1. SERVICING REQUIREMENTS

This appliance must be serviced at least once a year by a competent person.

All tests must be serviced by best practice as described by the current CORGI recommendations.

- 1.1 Before any test are undertaken on the appliance, conduct a gas soundness test for the property to ensure that there are no gas leaks prior to starting work.
- 1.2 Before any tests are undertaken on the appliance it is also recommended to fully check the operation of the appliance.
- 1.3 Special checks
  - 1.3.1 Clean any lint or fluff from the pilot - pay particular attention to the aeration hole in the side of the pilot
  - 1.3.2 Clean away any fluff or lint from under the burner
  - 1.3.3 Check that the spark gap on the pilot is correct
- 1.4 Correct any faults found during the initial tests and then re-commission the appliance conducting the usual safety checks.
- 1.5 Advise the customer of any remedial action taken.

#### IGNITION FUNCTIONAL CHECK 1

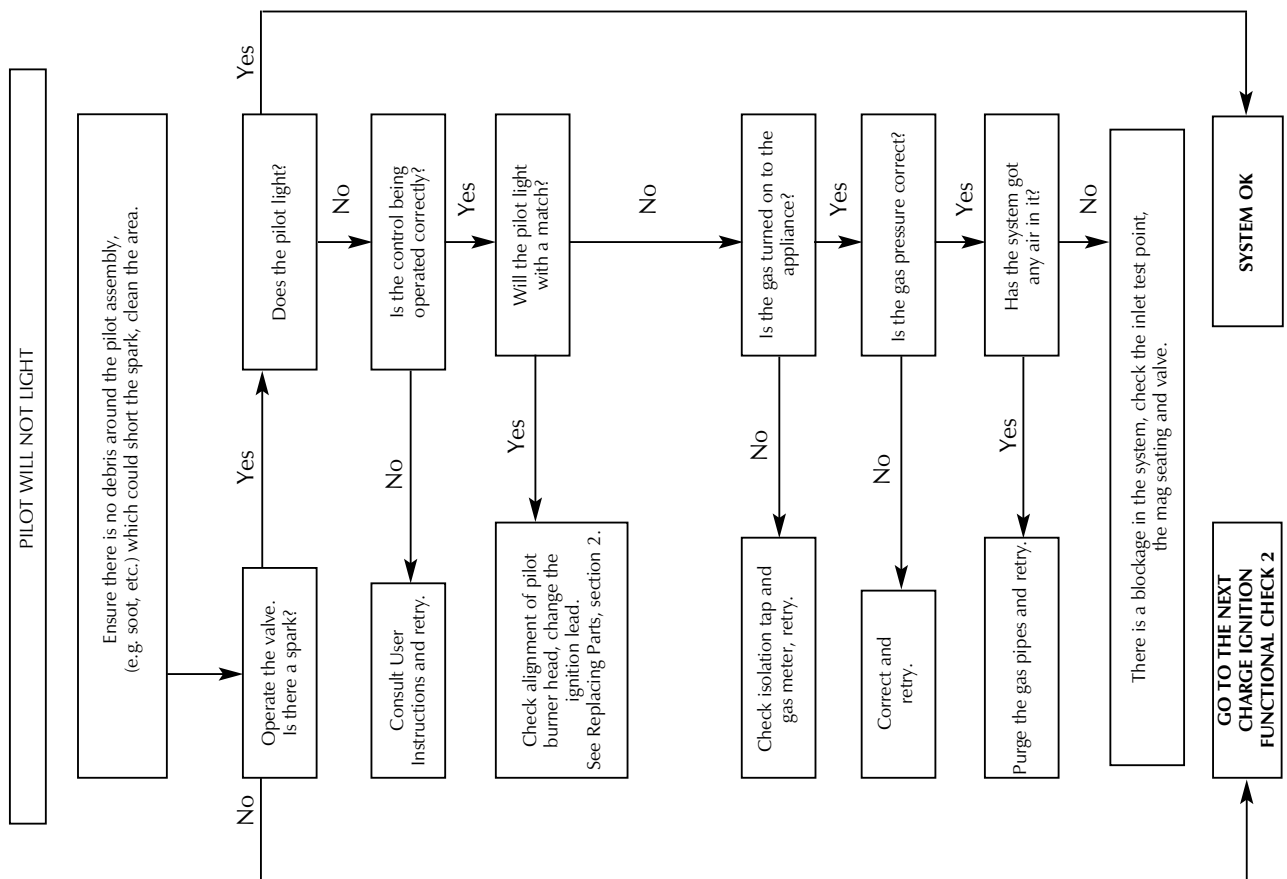





# SERVICING INSTRUCTIONS

## REPLACING PARTS

### 1. GENERAL

- 1.1 All principal components can be replaced without removing the appliance from its installation, although it is essential that the gas supply to the appliance is turned off at the isolation device before proceeding further.
- 1.2 If for any reason the flue has to be removed from the appliance, the seal must be replaced in the inner spigot.

### 2. MAIN BURNER

- 2.1 Turn the gas supply off at the isolation device, remove the decorative frame, see diagram 1.

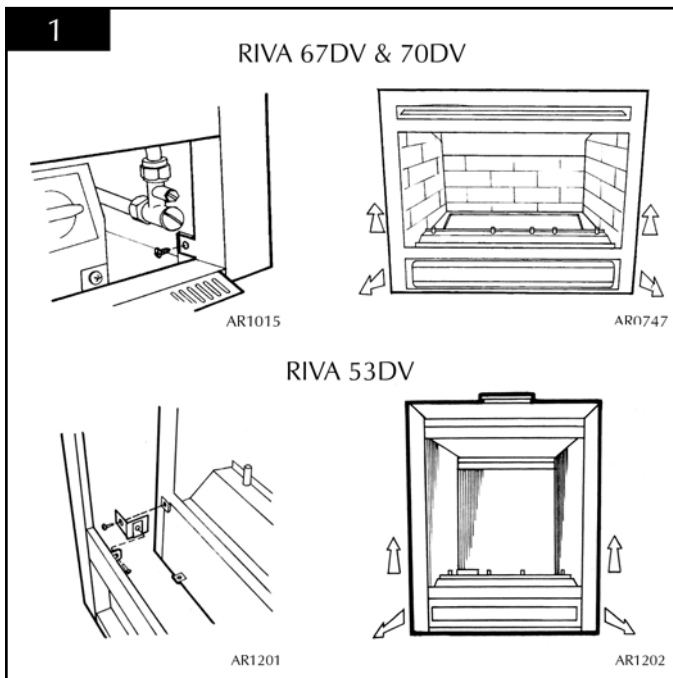

- 2.2 Remove the glass frame see diagram 2.

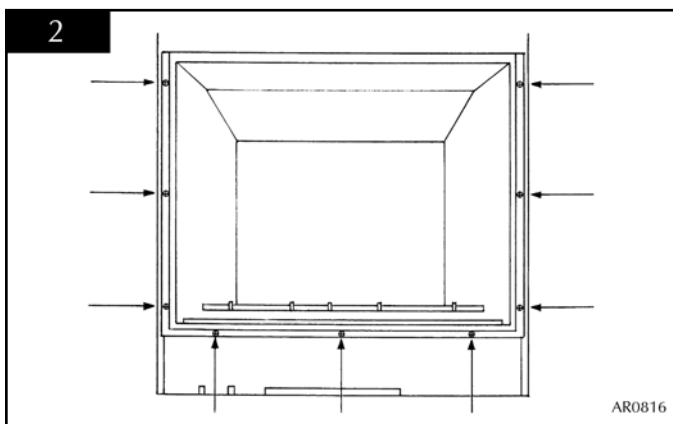

- 2.3 Remove the ceramic logs and the vermiculite.
- 2.4 Carefully slide the ceramic sides forward and store safely. See diagram 3.

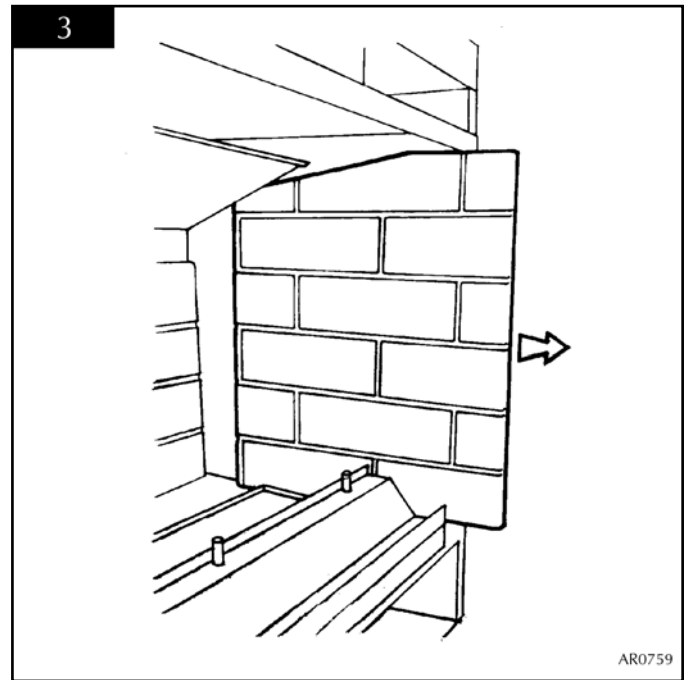

- 2.5 Remove the screws from the log support. The feed pipe nut is now visible between the burner and the angled base of the firebox. See diagram 4, arrow A.

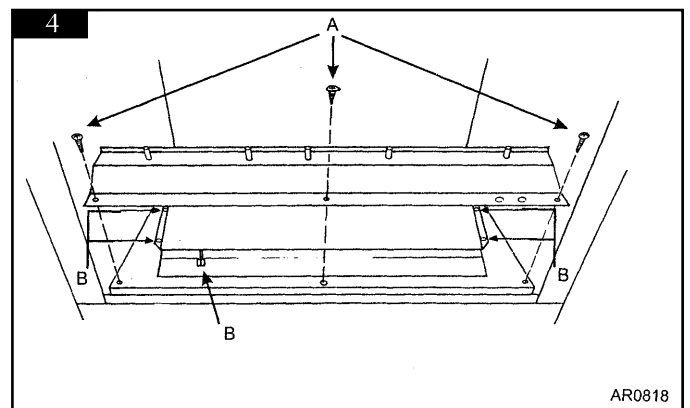

- 2.6 Undo the feed pipe nut and the four screws holding the burner to the tray. See diagram 4, arrow B. The burner, complete with the feed pipe, can now be removed.
- 2.7 To replace the burner, locate the feed pipe onto the brass fitting and loosely fit the nut. **DO NOT TIGHTEN THE NUT AT THIS STAGE.** Replace the four burner fixing screws, tighten the feed pipe nut.
- 2.8 Light the appliance and check for leaks.

# SERVICING INSTRUCTIONS

## REPLACING PARTS

### 3. PILOT UNIT

The pilot assembly consists of four components, which can be individually changed, these are:

- 1) Pilot burner bracket.
- 2) Pilot injector
- 3) Electrode
- 4) Thermocouple.

- 3.1 Turn off the gas supply at the isolating device, remove the outer frame, glass door and the logs. The vermiculite can be moved away from pilot cover to allow access, it does not need to be completely removed.
- 3.2 Remove the two screws securing the pilot burner to the pilot cover and the two screws securing the cover to the tray. See diagram 5. The pilot components can now be individually removed.

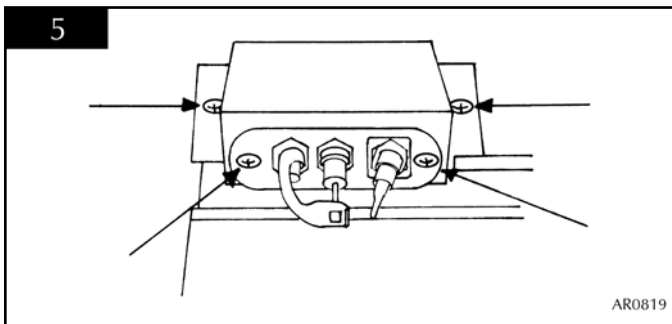

- 3.3 To remove the pilot injector, undo the compression nut on the pilot feed pipe and withdraw the injector which will be hooked onto the olive. When replacing an injector always ensure it is hooked onto the olive before inserting it into the pilot burner. See diagram 6, arrow A.

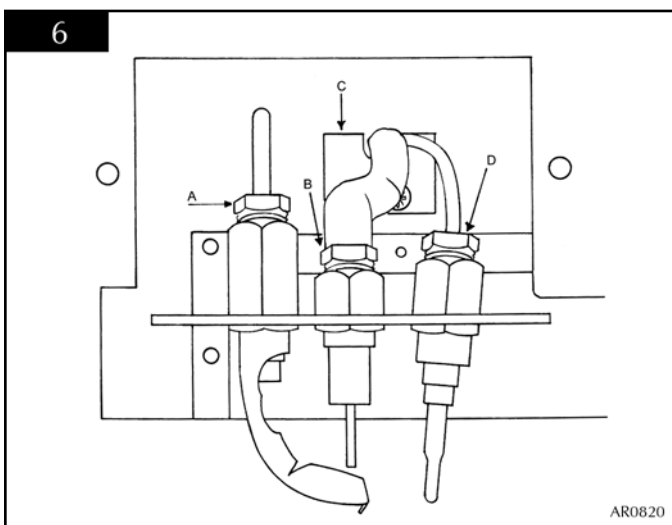

- 3.4 To remove the electrode, undo the retaining nut, withdraw the electrode from the pilot burner and disconnect the ignition lead. When replacing the electrode ensure the ignition lead is connected with the terminal pointing downwards. See diagram 6, arrow B.

- 3.5 To remove the thermocouple it will be necessary to remove the main burner, logs, vermiculite and log support as described in section 2.

WHEN REMOVING THE THERMOCOUPLE DO NOT DESTROY THE COMPONENT AS IT WILL BE NECESSARY TO PREFORM THE NEW COMPONENT TO THE SAME SHAPE. THIS WILL ASSIST WHEN FITTING THE NEW PART.

- 3.6 Once the main burner and pilot cover have been removed, there is a cover plate beneath the pilot assembly. Remove the screw and plate. This has been sealed with silicone to ensure no air enters the firebox. See diagram 6, arrow C.
- a) Undo the thermocouple retaining nut from the pilot burner. See diagram 6, arrow D.
  - b) Disconnect the inlet pipe at the pressure test point. See diagram 7.

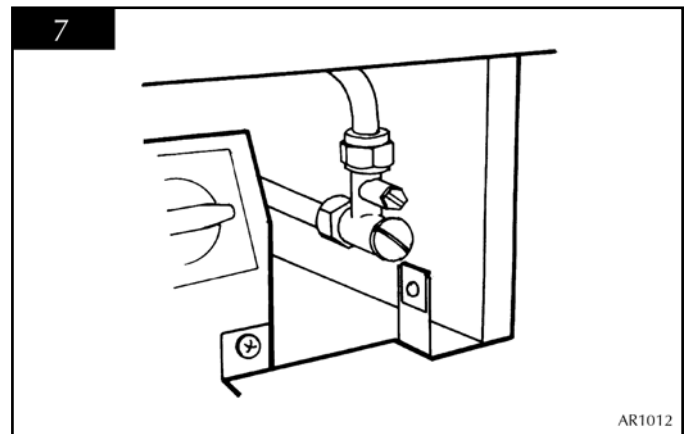

- c) Disconnect the external pilot pipe from the brass fitting. See diagram 8, arrow A.

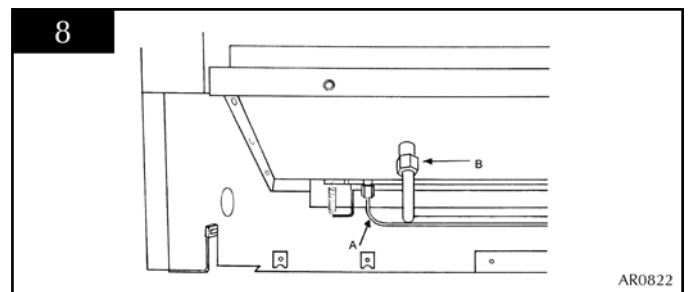

- d) Remove the external feed pipe from the brass fitting. See diagram 8 arrow B.
- e) Remove the 2 screws fixing the valve bracket to the base of the appliance.

# SERVICING INSTRUCTIONS

## REPLACING PARTS

f) Gently slide the gas valve and bracket forward and disconnect the thermocouple from the rear of the gas valve. See diagram 9, arrow A.

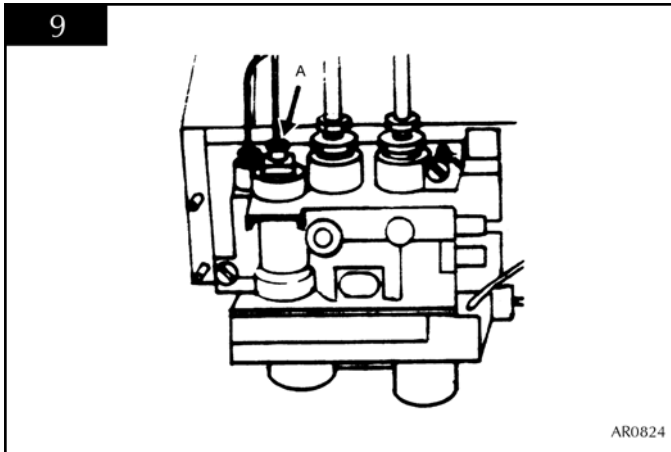

g) Push the thermocouple down through the hole in the base of the firebox and remove the component.

- 3.7 When fitting the new component after it has been shaped to the old thermocouple, push the tip (pilot end) through the hole from under the firebox floor. Do not insert the tip into the pilot burner at this stage.
- 3.8 Connect the thermocouple at the gas valve, do not over tighten the nut.
- 3.9 Assemble the gas valve bracket on to the firebox base and all pipes to the valve and fittings.
- 3.10 Insert the tip of the thermocouple into the pilot burner and tighten the nut. Replace the silicone around the thermocouple and ignition lead. Screw the plate into position, replace the pilot cover, log support and replace the ceramics.

### 4. IGNITION LEAD

- 4.1 Remove the screw from the left-hand side of the control cover. On the right hand side of the cover is a locking tab, this must be gently levered off the main body. Slide the cover forward. See diagram 10.

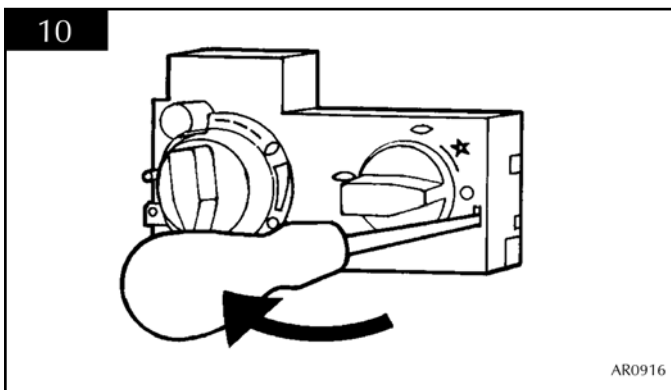

- 4.2 Pull the ignition lead off the piezo. Remove the burner as described in section 2, pilot cover and plate as described in section 3.
- 4.3 Disconnect the ignition lead from the electrode and push the lead complete with the vidaflex through the base of the appliance.
- 4.4 Cut the cable tie and remove the vidaflex sleeve. THIS MUST BE KEPT AND ASSEMBLED ON THE NEW LEAD. A CABLE TIE MUST ALSO BE USED TO RETAIN THE SLEEVE.
- 4.5 The lead can only be fitted one way round, ensure this is correct when refitting a replacement.
- 4.6 When replacing the cover plate ensure silicone sealant is used to seal the aperture.

### 5. PIEZO

- 5.1 The piezo assembly used on this appliance is not serviceable and is unlikely to fail.
- 5.2 If a new piezo is required it will be necessary to change the gas valve. Refer to section 6.

### 6. GAS VALVE

- 6.1 Turn the gas supply off at the isolation elbow, and disconnect from the inlet pipe on the fire.
- 6.2 Disconnect the feed pipe and pilot pipe from the brass fittings. See diagram 11.

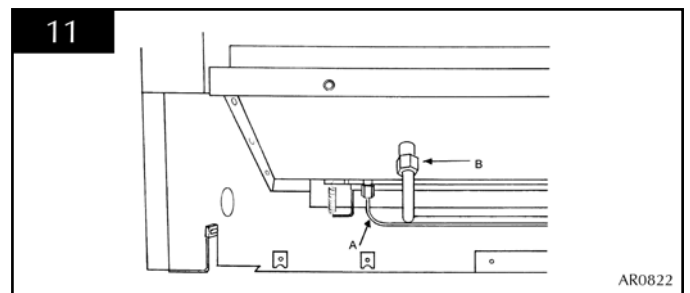

- 6.3 Remove the two screws retaining the valve bracket. See diagram 12.

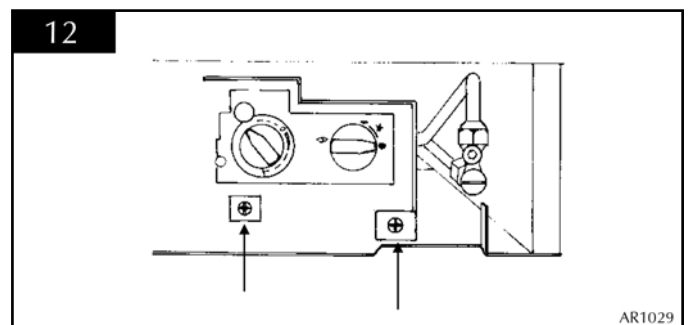

# SERVICING INSTRUCTIONS

## REPLACING PARTS

- 6.4 Remove the ignition lead as described in section 4.
- 6.5 The valve should now be able to be eased forward so the pipes and thermocouple can be removed from the rear of the valve.
- 6.6 Undo the two screws retaining the valve to the bracket.
- 6.7 Replace in reverse order.
- 6.8 Check all joints for gas leaks, check the operation of the thermocouple and ignition lead.

### 7. MAGNETIC SAFETY VALVE

- 7.1 Remove the gas valve as described in section 6.
- 7.2 Undo the magnetic valve retaining nut at the back of the control valve. Gently tap out the mag valve and replace with a new unit. See diagram 13. Replace in reverse order.

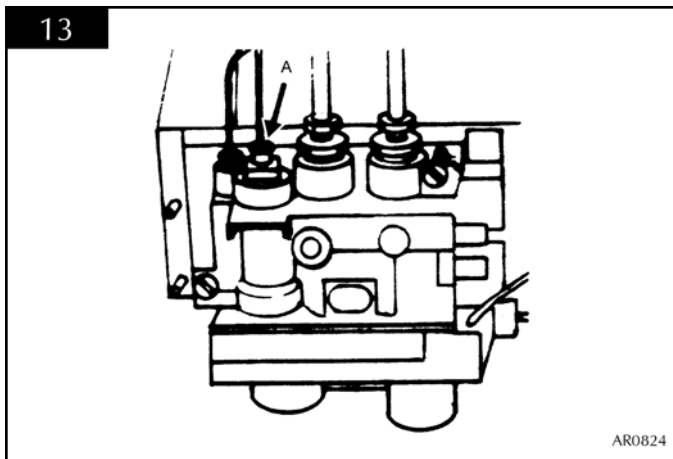

### 8. MAIN INJECTOR

- 8.1 Remove the burner module as described in Servicing section 2. Disconnect the pipe from the injector and the gas valve. See diagram 14.

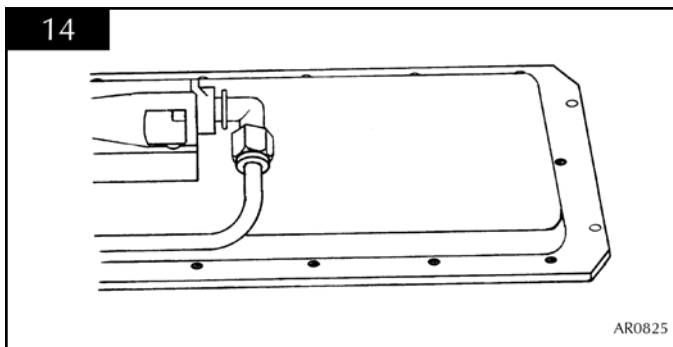

- 8.2 Rotate the injector until it is fully removed, and install the correct replacement injector. Re-assemble and turn the gas supply on, check for any leaks.

### 9. PRIMARY AERATION PLATE

NOT ALL MODELS HAVE AERATION PLATES. REFER TO NOTE AT BEGINNING OF INSTALLATION INSTRUCTIONS.

- 9.1 Remove the burner module as described in Servicing section 2.
- 9.2 Remove the fixing screw and slide the plate off the venturi.
- 9.3 Replace with the correct size plate and secure with the screw. Ensure the lower edge of the plate is located over the venturi flange. See diagram 15.

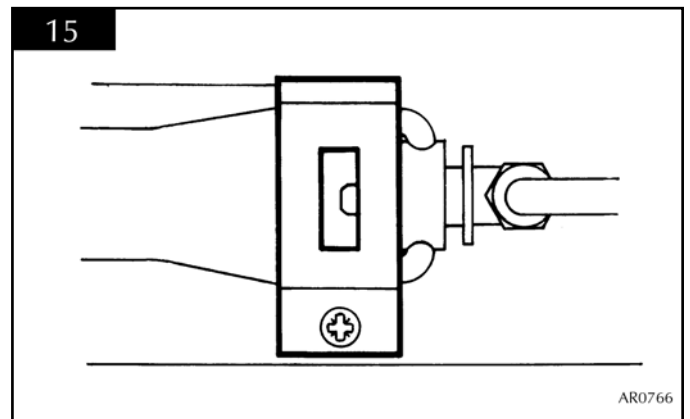

### 10. CHANGING BETWEEN GAS TYPES

In order to change between gas types, it will be necessary to change the following items:

- Burner Unit**
- Pilot Injector**
- Control Valve**
- Injector**
- Aeration Plate (if required)**
- Databadge**

A kit of parts is available for this, always quote the Model number and Serial number when ordering any spare parts.

**NOTE: THE CONTROL VALVE IS FACTORY PRESET FOR THE CORRECT GAS TYPE AND MODEL, A NEW UNIT WILL NEED TO BE ORDERED WHEN CHANGING BETWEEN GAS TYPES.**

### 11. CONTROL UPGRADE

See Installation Instructions, section 1.

# SERVICING INSTRUCTIONS

## REPLACING PARTS

### 12. SHORT SPARES LIST

Model	RIVA 53 DV		RIVA 67 DV		RIVA 70DV	
	NG	LPG	NG	LPG	NG	LPG
PILOT INJECTOR	PI0026	PI0015	PI0026	PI0015	PI0026	PI0015
MAIN INJECTOR	IN0029	IN0051	IN0035	IN0040	IN0005	IN004
AERATION PLATE	NATURAL GAS		NATURAL GAS		NATURAL GAS	
	G20	G25	G20	G25	G20	G25
	GZ2025	GZ3966	GZ3865	GZ3866	N/A	GZ2025
BURNER UNIT	N/A		GZ3122		GZ3122	
AERATION PLATE	LPG		LPG		LPG	
	G30	G31	G30	G31	G30	G31
	GZ3865	GZ2003	GZ2025	GZ3270	N/A	GZ2016
BURNER UNIT	N/A		GZ3123		GZ3123	
GAS VALVE*	GC0088		GC0088		GC0088	
THERMOCOUPLE	PI0063		PI0063		PI0063	
MAG UNIT	GC0092		GC0092		GC0092	
IGN LEAD	GC0090		GC0090		GC0090	
SPARK ELECTRODE	PI0053		PI0053		PI0053	
CERAMIC LINERS			BRICK EFFECT	BLACK RIBBED	BRICK EFFECT	BLACK RIBBED
REAR CERAMIC PANEL	CE0388		CE0326	CE0345	CE0329	CE0348
L/H CERAMIC PANEL	CE0386		CE0327	CE0346	CE0330	CE0349
R/H CERAMIC PANEL	CE0387		CE0328	CE0347	CE0331	CE0350
VERMICULITE	CE0423		CE0376		CE0376	
LOG SET	CE0415		CE0306		CE0306	
LOG 1	CE0416		CE0307		CE0307	
LOG 2	CE0417		CE0308		CE0308	
LOG 3	CE0418		CE0309		CE0309	
LOG 4	CE0419		CE0310		CE0310	
LOG 5	CE0420		CE0311		CE0311	
LOG 6	CE0421		CE0312		CE0312	
LOG 7	CE0422		CE0313		CE0313	
CONVECTION FAN KIT	8576		8571		8571	
DUCT KIT	8572		8572		8572	
STANDARD UPGRADE KIT	8455		8455		8455	
TIMER/THERMO. UPGRADE KIT	8456		8456		8456	
WINDOW FRAME ASSEMBLY	GZ3991		GZ3747		GZ3382	

\* Gas Valve is pre-set for the appliance



**Gazco Limited, Osprey Road, Sowton Industrial Estate, Exeter, Devon, England EX2 7JG**  
**Tel: (01392) 261999 Fax: (01392) 444148 E-mail: [info@gazco.com](mailto:info@gazco.com)**

A member of the Stovax Group