

GULFSTREAM 2000

A Combined Primary Storage Unit (CPSU) for Domestic Hot Water Supply and Central Heating

Appliance Category 1_{2H} Types C₁₃ : C₅₃ : C₃₃

Destination GB : IE, Nox CLASS 5

Intended for use with a governed meter only

DESIGN, INSTALLATION AND SERVICING INSTRUCTIONS

PLEASE LEAVE THESE INSTRUCTIONS IN THE POCKET PROVIDED ON
THE BACK OF THE FRONT PANEL

Customer Reference	For a dwelling with a design heat loss of up to	Gas Council/Approval Reference	
12 OV	12kW (40,000 Btu)	GS2000/120/E-OV	
12 SP	12kW (40,000 Btu)	GS2000/120/E	EC-55-317-30
18 OV	18kW (61,000 Btu)	GS2000/130/E-OV	
18 SP	18kW (61,000 Btu)	GS2000/130/E	EC-55-317-32
25 OV	25kW (85,000 Btu)	GS2000/130/E-OV	
25 SP	25kW (85,000 Btu)	GS2000/130/E	EC-55-317-32

FOR USE WITH NATURAL GAS ONLY (G20) SUPPLY PRESSURE 20mbar

These instructions are to be followed and specification of the appliance must not be modified unless recommended by Gledhill Water Storage Limited.

THE GAS SAFETY (INSTALLATION AND USE) REGULATIONS

"In your own interest, and that of safety, it is law that all gas appliances are installed by competent persons, in accordance with the above regulations. Failure to install appliances correctly could lead to prosecution."

IMPORTANT - Control of Substances Harmful to Health:

When working with insulation materials, avoid inhalation as it may be harmful to health. Avoid contact with skin, eyes, nose and throat, use disposable protection. Dampen the material and ensure that the area is well ventilated.

In the interest of continuously improving the GulfStream²⁰⁰⁰ range. Gledhill Water Storage Ltd reserve the right to modify the product without notice and in these circumstances this booklet which is accurate at the time of printing should be disregarded.



CONTENTS

ISSUE 4: 01-03

Section	Page
Description	4
Introduction	4
Clearances & Cupboard Sizes	5
Boiler	6
Gas Supply/Electrical Supply	9
Appliance Location	10
System Design	
Ventilation	11
Hot and Cold Water System	11
Space Heating System	13
Flue System Design	
General Requirements	17
Installation and Wiring	
Handling/Storing the Appliance	18
Fitting the Appliance	18
Electrical Wiring	21
Commissioning	
General	23
Initial System Filling	23
Cleansing & Water Treatment	23
Flue & Air Pipes	23
Initial Lighting	23
Gas Rate & Gas Pressure	26
Procedure for checking and adjusting gas rate and burner pressure	26
Final Adjustments	27
External Controls	27
User Instructions	28
Fault Finding	29
Servicing	38
Component Exchange	40
Spare Parts List	43
Terms & Conditions	45



*The code of practice for the installation,
commissioning & servicing of central heating systems*

As part of the industry wide "Benchmark" Initiative all Gledhill GulfStream boilers now include a Benchmark Installation, Commissioning and Service Record Logbook. Please read this carefully and complete all sections relevant to the appliance installation. The details of the Log book will be required in the event of any warranty work being required. There is also a section to be completed after each regular service visit. **The completed Log Book and these instructions should be left in the pocket provided on the back of the front panel.**

The boiler should be installed and serviced only by CORGI registered operatives. All CORGI registered Installers carry a CORGI ID card, and have a registration number.

Both should be recorded in the Benchmark Log Book. You can call CORGI direct on 01256 372300.

Gledhill Water Storage Limited
Sycamore Estate
Squires Gate
BLACKPOOL
Lancs
FY4 3RL

IMPORTANT NOTICE

Any installation must be in accordance with the relevant requirements of the current issue of Gas Safety (Installation and Use) Regulations, Local Building Regulations, the Building Standards (Scotland) Consolidations, I.E.E. Wiring Regulations, Local Water Company Byelaws and Health & Safety Document No. 635 - The Electricity at Work Regulations 1989. Detailed recommendations are contained in the current issue of the following British Standards and codes of practice :-

BS 5440 Pts.1 & 2; BS 5449; BS 5546; BS 7074 Part 1.
BS 6700; BS 6798; BS 6891; BS 7593. IGE/UP/7/1998.

Gas Consumer Council

The Gas Consumer Council (GCC) is an independent organisation which protects the interest of gas users. If you need advice, you will find the telephone number in your local telephone directory under Gas.

General

Details of essential features of cupboard design are given in BS 6798.

This information is provided to assist generally in the selection of equipment. Responsibility for selection and specification of our equipment must, however, remain that of our customers and any experts or consultants concerned with the installation(s).

PLEASE NOTE THAT WE DO NOT THEREFORE ACCEPT ANY RESPONSIBILITY FOR MATTERS OF DESIGN SELECTION OR SPECIFICATION, FOR THE EFFECTIVENESS OF AN INSTALLATION OR UNIT CONTAINING ONE OF OUR PRODUCTS.

All goods are sold subject to our Conditions of Sale which are set out in the Appendix to this Specification.

WARNING

The GulfStream is for use on natural gas only and must not be used on any other gas.

This appliance must be serviced by a competent person e.g. a Corgi Registered Installer.

If sealed components are replaced and re-commissioned in the field then these must be re-sealed.

A WRAS APPROVED PRODUCT.

British Patent No: Patent Pending

DESCRIPTION



Figure 1 Models 2000/120/E 2000/130/E



Figure 2 Models 2000/120/E-OV
2000/130/E-OV

INTRODUCTION

GulfStream 2000 (figures 1 and 2) is a room sealed, gas fired, fan flued condensing Combined Primary Storage Unit for supplying wet central heating and mains pressure hot water for dwellings with a design heat loss of up to 25kW. The principle is to separate the heat generator (i.e. the boiler) from the heat emitters (i.e. the radiators and the domestic hot water generator) by a thermal store. This evens out the fluctuating demands for heating and hot water and significantly improves the system efficiency.

Another important feature of the system is that because the thermal store acts as a buffer between the boiler and the heating system, any variety of space heating control systems can be used, although the heating system circulating pump is an integral part of the appliance. This aspect is discussed further on in this manual.

An important feature of this design is that domestic hot water can be supplied directly from the mains without the need for additional safety controls in the DHW supply. This is achieved by passing the mains water through a high performance plate heat exchanger. The outlet temperature of the domestic hot water is maintained by a printed circuit board which controls the speed of the pump which circulates primary hot water from the thermal store through the primary side of the plate heat exchanger. This is shown in Figures 4-7.

Because of the innovative method of hot water production no in-line scale reducer is required on the cold supply to the appliance. If scale should become a problem the plate heat exchanger is easily isolated and replaced with a service exchange unit.

The GulfStream high efficiency appliance is fitted with a unique electric emergency backup system for both heating and hot water.

TECHNICAL DATA

All models are supplied with 9kW electric boiler for emergency backup for heating and hot water. They are fused internally at 5A for gas circuit. A 230V \sim , 50Hz electricity supply fused at 45A is required direct from the consumer unit.

The models GC 2000/120/E and 130/E are suitable for sealed heating system. The models GC 2000/120/E-OV and 130/E-OV are suitable for open vented systems only.

DESCRIPTION

CLEARANCES AND CUPBOARD SIZES

Sizes - All models overall -

H	W	D	D
1300mm	595mm	595mm	595mm

Ensure compliance with the following:

Clearances required for installation and servicing:

Top 450mm

Base nil - appliance is plinth mounted

Rear (5-150)mm depending on flue application

Left Hand Side 10mm from door frame

Right Hand Side 10mm from door frame

Front 600mm for servicing.

The appliance should be cleaned with a non abrasive cleaning agent.

Minimum internal cupboard size required:

* H	W	D*
1850mm	700mm	(620-745)mm - SP Model
2300-2500mm	700mm	(620-745)mm - OV Model

* Assumes plinth height is 100mm from finished floor level and, in the case of the OV Model, that the F & E cistern is installed in the same cupboard as the appliance.

Height of 2300 can only be used if the F & E cistern is installed length ways on the R.H. side of the cupboard (see opposite) to allow sufficient access to the boiler.

*Depth required depends on flue application.

Domestic Hot Water Pressure/Flow Characteristics:

Minimum flow to operate 1.5 l/min.

Minimum inlet pressure to obtain nominal flow rate:

1 bar dynamic

Maximum recommended water pressure 5 bar

Specific water rate:

Models GC2000/130/E,/130/E-OV 23.3 l/min

Models GC2000/120/E,/120/E-OV 15.3 l/min

Central Heating Circuit Characteristics:-

a. Sealed System Models

Minimum water pressure 0.5 bar

Maximum water pressure 3.0 bar

Maximum stored water temperature $82 \pm 2^\circ\text{C}$

b. Open Vented System Models

Minimum static head : 300mm - Above the highest point of the system.

Maximum static head : 10m - From the top of the appliance

Maximum stored water temperature : $82 \pm 2^\circ\text{C}$

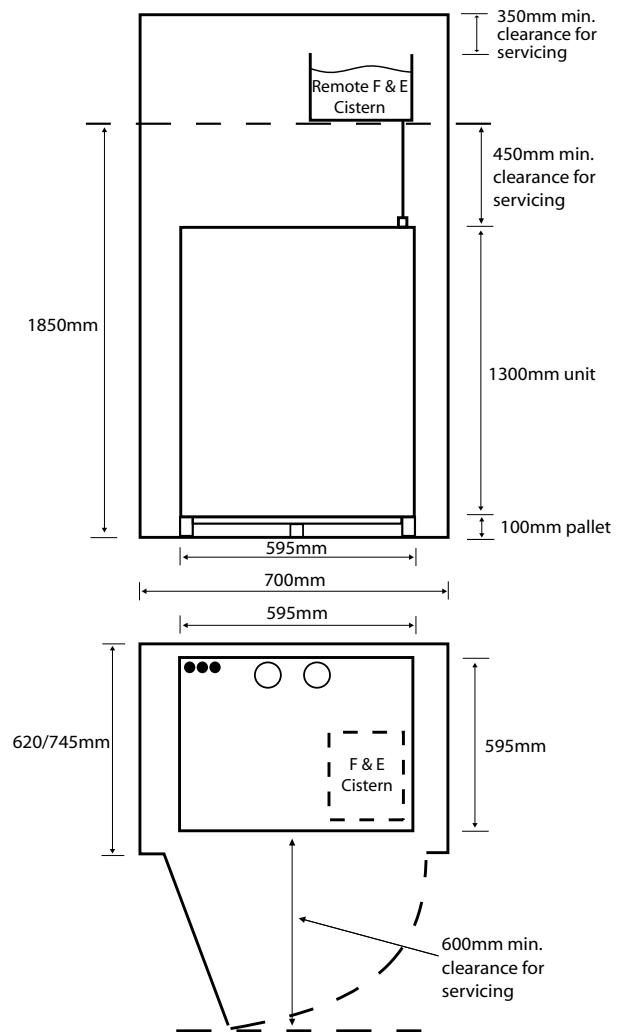

Figure 3 Minimum Clearances and Cupboard Dimensions

NOTE: 350mm is required above the F & E cistern for maintenance access to comply with the Water Regulations.

TABLE 1 GULFSTREAM²⁰⁰⁰ PERFORMANCE DATA

MODELS	HEAT OUTPUT								BURNER PRESSURE OFFSET	GAS RATE		FLUE GASSES MAX. FLOW RATE
	Maximum		Minimum		Maximum		Minimum			Max.	Min.	
	Condensing kW	NonCondensing kW	Condensing kW	NonCondensing kW	Nett kW	Gross kW	Nett kW	Gross kW		m ³ /h	m ³ /h	
GC2000/120 120-OV,120/E and 120/E-OV (Units 120V & 125P)	19.8	18.1	8.79	8.03	19.4	21.5	8.7	9.67	(-10/-12)	2.05	0.74	13.5
GC2000/130 130-OV, 130/E and 130/E-OV (Units 18/25OV & 18/25SP)	29.3	27.4	8.79	8.03	29.0	32.2	8.7	9.67	(-18/-20)	3.07	0.74	9.0

DESCRIPTION

Model	120V	12SP	180V	18SP	250V	25 SP
Height (mm)	1300	1300	1300	1300	1300	1300
Width (mm)	595	595	595	595	595	595
Depth (mm)	595	595	595	595	595	595
Hot water flow rate (l/m)	up to 35	up to 35	up to 35	up to 35	up to 35	up to 35
Max property heat loss (kW)	12	12	18	18	25	25
Weight (empty) (kg)	92	94	92	94	92	94
Weight (full) (kg)	172	174	172	174	172	174
Property Selection Guide						
Bedrooms	1-3	1-3	2-4	2-4	3-6	3-6
Bedrooms	1	1	1	1	2 1	2 1
En-suite shower	1	1	2	2	1 3	1 3
NOTES : The flow rates are based on a 35°C temperature rise and assume the recommended pressure and an adequate flow are available at the appliance. The domestic hot water outlet temperature is automatically regulated to approximately 55°C at the bath flow rate of 18 litres/min recommended by BS 6700. The temperature is not user adjustable						

TAPPINGS
 ½" BSPF expansion relief BS21 gas cock. Heating flow and return cold mains and hot draw off all 22mm compression.

BOILER

The GulfStream is a room sealed fanned flued condensing boiler with a range of flueing options. The boiler incorporates the latest in gas appliance technology.

FEATURES

- Emergency heat back-up --- Both sealed and open vented system models in the GulfStream 2000 range are supplied with an integral 9kW electric boiler for emergency heat back-up for heating and hot water.
- Automatic control --- Specially designed electronic controls with electronic ignition (no pilot), boiler thermostat and indicator light display mounted on the front fascia panel of the appliance. Fitted with all items required for fully pumped sealed systems.
- Choice of room sealed - multi directional concentric/twin pipe flueing systems --- Options include:-
 1. **Ridge Terminal Flue Kit** - The un-balanced ridge terminal flue system comprises a number of push fit socketted concentric and single pipe components and is designed to allow air to be taken from the roof space and the flue gases to be discharged to atmosphere through a suitable ridge tile terminal.
 2. **Gable Terminal Flue Kit** - The un-balanced flue kit system comprises a number of push fit socketted concentric and single pipe components and is designed to allow air to be taken from the roof space and the flue gases to be discharged to atmosphere through a suitable concentric gable wall terminal.
 3. **Balanced Flue Terminal Kit** - The standard balanced flue kit comprises a number of push fit socketted concentric components and is designed to allow the appliance to be fitted internally on an outside wall with the air inlet and flue gas outlet discharged direct to atmosphere through a suitable concentric gable wall terminal. The arrangement is suitable for rear, left or right hand discharge.
 4. **Twin Pipe Horizontal Flue Kit** - The balanced twin pipe flue system comprises a number of push fit socketted concentric and single pipe components. It is designed to allow the installation of flues within ceiling voids, or ducts, in apartments with the fresh air and flue exhaust being provided from a concentric wall terminal built into the external wall.
 5. **Roof Terminal Flue Kit** - The balanced roof terminal flue system comprises a number of push fit socketted concentric components and is designed to allow air and the flue gases to be discharged to atmosphere through a suitable concentric roof terminal. Pitched and Flat Roof options are both available.
- The air intake and flue discharge pipes are connected to sockets positioned top - rear of the GulfStream. From this point they may be run in any direction sanctioned within this literature.
- Latest pre-mix burner technology gives low Nitrogen Oxide values --- meets all proposed EC requirements and helps reduce acid gas emissions and environmental damage. NOx - 17ppm.
- Combustion efficiency is higher and volumes of CO and NOx are lower compared with traditional atmospheric burners running at the same heat input.
- The nominal maximum NOx emission from the appliance is 30mg/kWh. This is well within the EC requirement of 70mg/kWh maximum for inclusion as a Class 5 appliance.
- High efficiency, low weight, low thermal capacity aluminium heat exchanger.

OPTIONAL EQUIPMENT

- Grasslin digital clock
- Flexible connection kit. For further details see Installation & Wiring - 2. Fitting The Appliance.
- Grundfos 15/60 pump - for space heating only.

DESCRIPTION

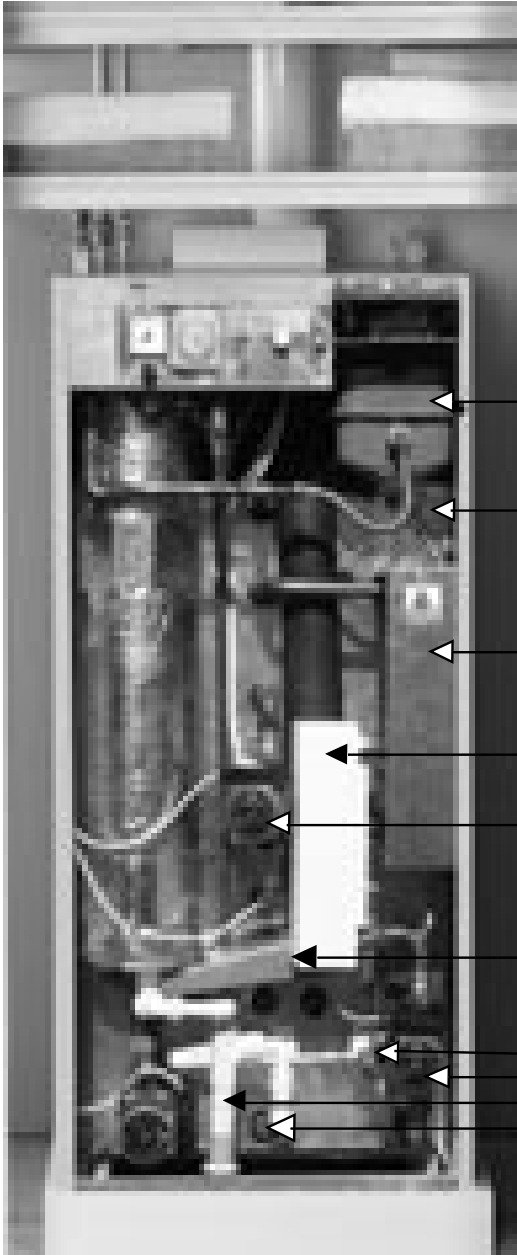

- Expansion vessel
- Thermal store
- 9KW emergency back-up electric boiler. Models 120/E and 130/E only
- DHW plate heat exchanger
- Central heating pump
- Flue gases/combustion sampling point
- Y Type Strainer
- DHW pump
- Condensate trap
- Drain

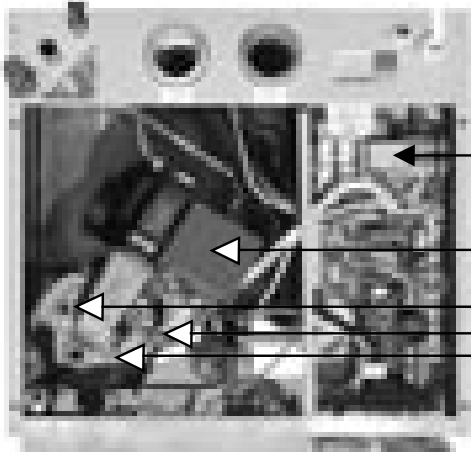

- See figure 21
- Honeywell MFC gas valve
- Flame sensor
- Dry firing stat
- Flame ignition electrode

Figure 4 GulfStream 2000/120/E and 2000/130/E (suitable for sealed systems only)

DESCRIPTION

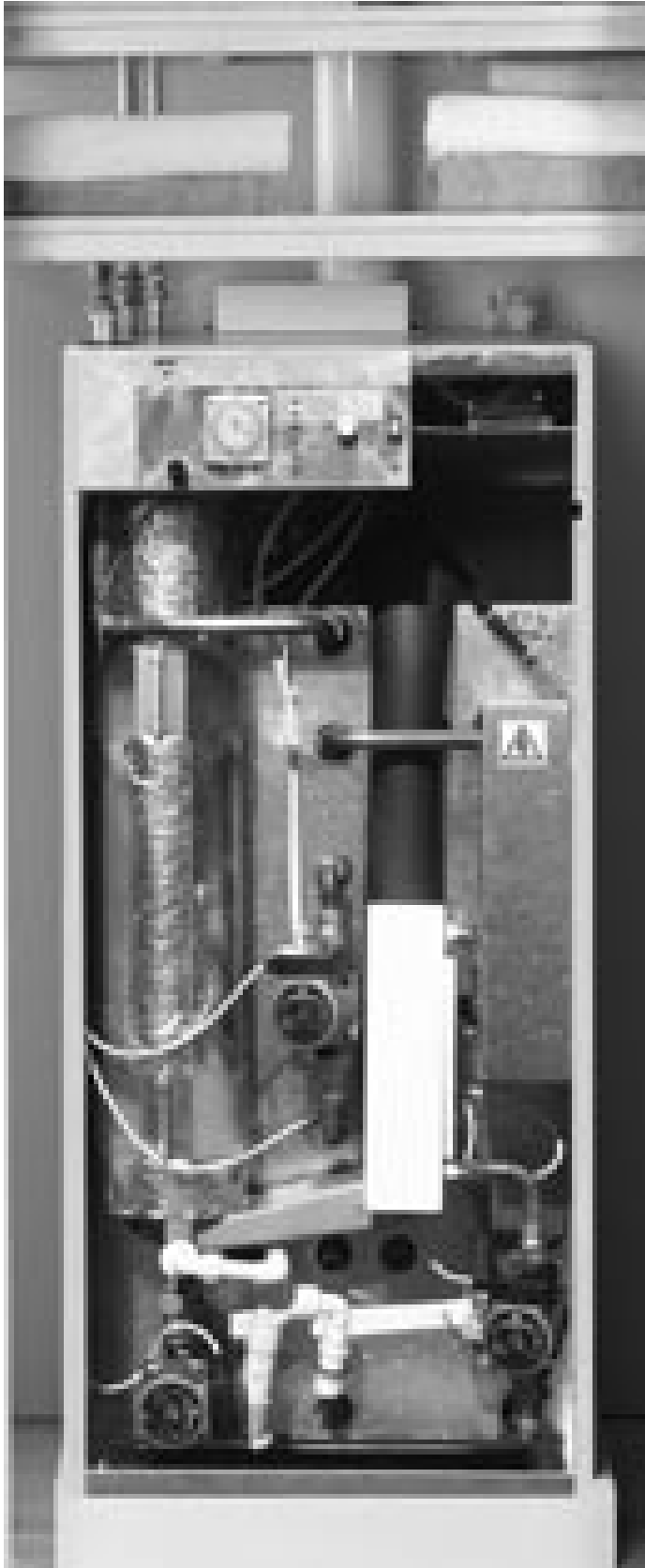

Figure 5
GulfStream 2000/120/E-OV and 2000/130/E-OV
(suitable for open vented systems only)

DESCRIPTION

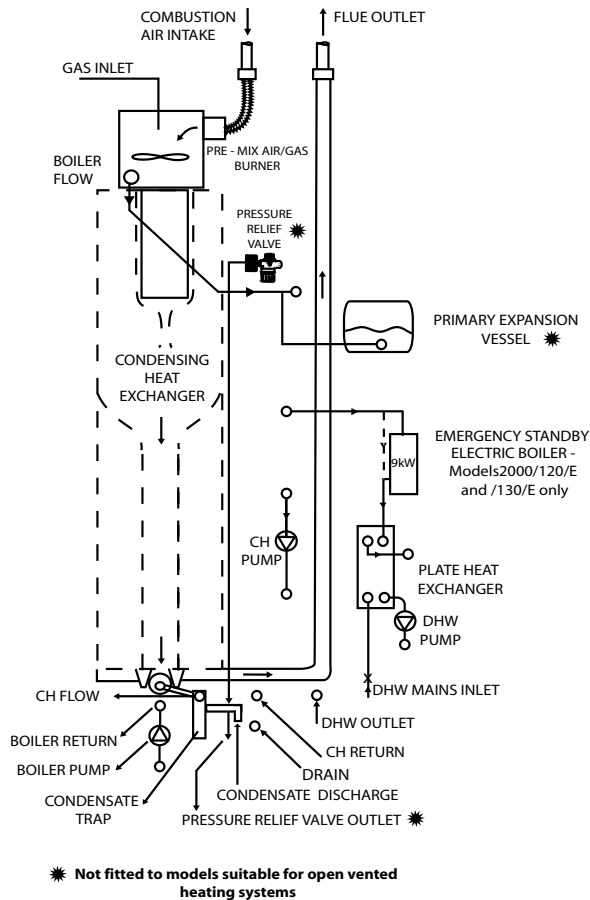

Figure 6 Schematic Diagram

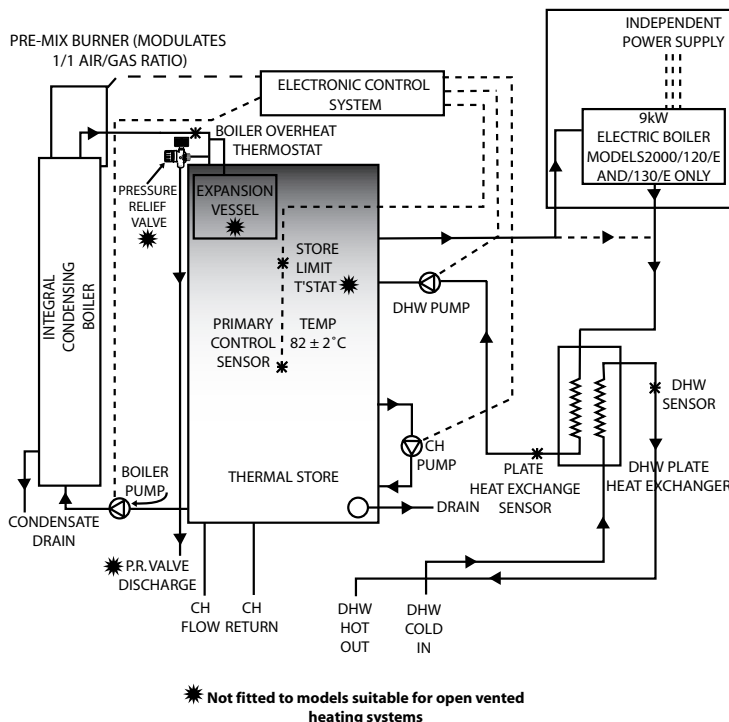

Figure 7 Appliance Hydraulic and Control System

GAS SUPPLY

1. The Local Gas Supplier should be consulted at the installation planning stage in order to establish the availability of an adequate supply of gas.
2. An existing service pipe **MUST NOT** be used without prior consultation with the Gas Supplier.
3. A gas meter can only be connected by the Local Gas Supplier or by his Contractor.
4. An existing meter should be of sufficient size to carry the maximum boiler input plus the demand of any other installed appliance, (BS 6891 :1988). See section Technical Data for the gas required for each specific model. Table 1.
5. A minimum of 22mm diameter pipework to within 1 metre of the appliance gas cock should be fitted.
6. The governor at the meter must give a constant outlet pressure of 20mbar when the appliance is running.
7. The gas supply line should be purged. **WARNING:** before purging open all doors and windows, also extinguish any cigarettes, pipes, and any other naked lights.
8. The complete installation must be tested

ELECTRICAL SUPPLY

1. The mains supply required is 230V \sim 50Hz. All GulfStream 2000 models are fused internally. Minimum external fuse rating and the mains supply cable specification will vary according to model type. Refer to "Electrical Wiring" for complete details. All fuses must be ASTA approved to BS 1362. **THE APPLIANCE MUST BE EARTHED.**
2. All external wiring to the boiler must be in accordance with the latest I.E.E. Wiring Regulations, and any local regulations which apply.
3. There must be only one common isolator for the boiler and its control system, and it must provide complete electrical isolation via a fused double pole isolator with a contact separation of at least 3mm in both poles.
4. In the event of an electrical fault after installation of the appliance, preliminary electrical systems checks must be carried out i.e. Earth Continuity, Short Circuit, Polarity, and Resistance to Earth.

APPLIANCE LOCATION

The following limitations **MUST** be observed when siting the boiler:

1. **The appliance is room sealed and can be located in any room/compartment in a domestic property. The appliance is essentially quiet but does incorporate a fan/pumps. The chosen position should bear this in mind and not be one which is particularly sensitive to noise.**
2. The boiler is not suitable for external installation. The position selected for installation should be within the building, unless otherwise protected by a suitable enclosure, and **MUST** allow adequate space for installation, servicing, and operation of the appliance, and for air circulation around it.
3. This position **MUST** allow for the flue and air inlet system to be fitted in its correct position.
4. The boiler must be installed on a flat surface which is capable of supporting the weight of the appliance and any ancillary equipment.
5. If the boiler is to be fitted in a timber framed building it should be fitted in accordance with the British Gas publication 'Guide for Gas Installations Timber Frame Housing', Reference IGE/UP/7:1998. If in doubt, advice must be sought from the Local Gas Supplier.
6. A compartment used to enclose the appliance **MUST** be designed and constructed specifically for this purpose. An existing cupboard, or compartment, may be used provided it is modified accordingly. BS 6798 gives details of the essential features of cupboard/compartment design, including airing cupboards.
7. **It is sensible to put sound deadening material (felt) between the boiler and the floor to absorb any vibration from the pumps/fan etc.**

HOT WATER PERFORMANCE

The hot water performance of the appliances is shown in Figure 8. The flow rates and corresponding maximum water volumes drawn off and quoted in Table 1 assume normal dynamic water pressure and adequate flow to the property. The mixed flow temperature will provide a 35°C rise when water is drawn off at up to 35 l/min as shown, if the maximum water volume is not exceeded.

For the nominal 35°C temperature rise, the maximum hourly rate of the 20kW and 30kW models is 550 litres and 780 litres respectively.

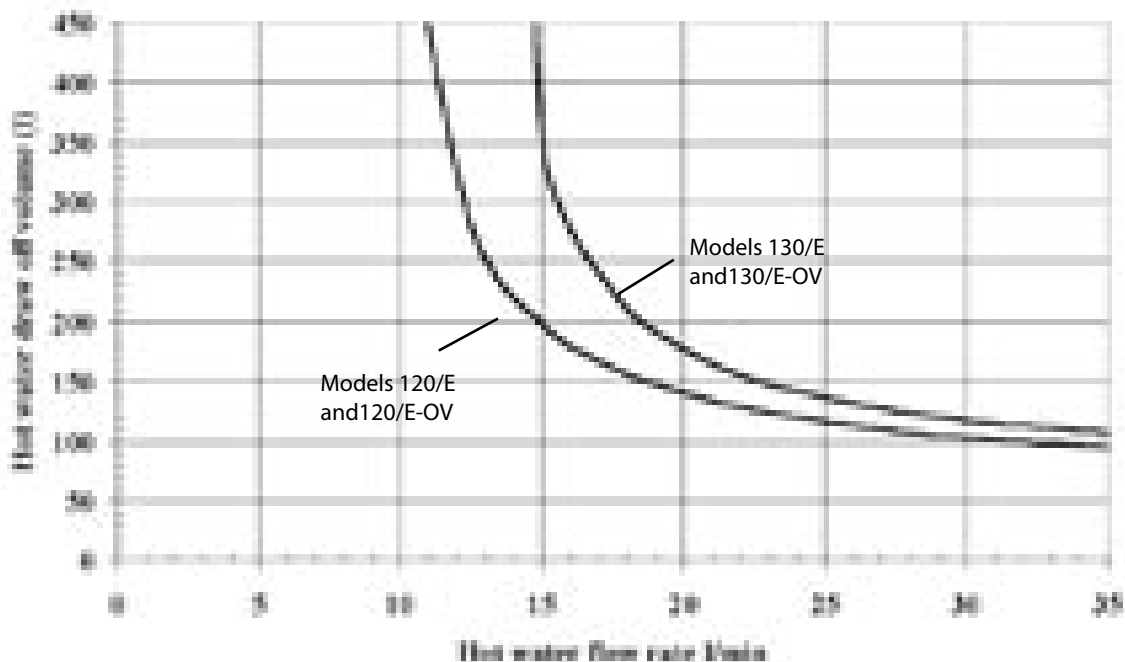

Figure 8 Hot Water Performance

1. VENTILATION

The appliance is room sealed and it is not a mandatory requirement to provide ventilation to the appliance cupboard.

However, in many cases the appliance cupboard is also used as an airing cupboard and in these situations some ventilation openings at high and low level will be helpful in providing air movement,.

2. HOT & COLD WATER SYSTEM

2.1 Mains Pressure Domestic Hot Water Supply

1. GulfStream models are designed to be fed directly from the mains. They fulfill the requirements of Water Byelaw 91, and therefore do not require a check valve to be fitted to the supply pipe. The performance of the GulfStream is directly related to the adequacy of the cold supply to the dwelling. This must be capable of providing for those services which could be required simultaneously and the maximum demand should be calculated. GulfStream OV model will operate at pressures as low as 1 bar which must be available when local demand is at its maximum, but the preferred range is upwards of 2 bar. 2 bar must be available at all times for the correct operation of the SP model for the automatic filling device to function correctly. As a general guideline, although a 15mm service may be sufficient for the smaller dwelling with one bathroom, a 22mm service is preferred (25mm MDPE) and should be the minimum for larger dwellings, and properties above two storeys.
2. If a water meter is fitted in the service pipe, it should have a nominal rating to match the anticipated maximum simultaneous hot and cold water demand, calculated in accordance with BS 6700. This could be 50 litres per minute in some properties.
3. If the incoming static mains water pressure exceeds 5 bar at any point in the 24 hour cycle then a pressure limiting valve set at 3 bar should be fitted downstream of the stop tap where the cold supply enters the property. Units must be fitted strictly in accordance with the requirements of the Local Water Undertaking who should be consulted prior to installation. In the event of any difficulty please contact ourselves as the manufacturer.
4. Equipment used in the system should be suitable for a working pressure of 5 bar. A non-return valve is not required. Should ancillary equipment, requiring a non-return valve, be fitted to the same mains supply as the GulfStream, then this valve must not be fitted between the inlet of this mains supply to the house and the GulfStream.
No safety fittings are required on the secondary system.

2.2 Use in hard water areas

A patented control system prevents domestic water from exceeding 55°C for most of the operational time of the appliance.

IT IS NOT NECESSARY TO FIT ANY FORM OF SCALE INHIBITING EQUIPMENT IN THE DOMESTIC COLD SUPPLY TO THE APPLIANCE.

If it ever becomes necessary the plate heat exchanger is easily replaced with a service exchange unit without complete drain down.

2.3 Cold and hot water distribution network

1. Although a 15mm copper supply may be adequate for the smaller 1 bathroom dwelling, a 22mm (25mm MDPE) supply is preferred where possible to make best use of this appliance.
2. Internally run in 22mm copper to the GulfStream and from the GulfStream in 22mm past the hot draw-off to the bath.
3. **We would recommend that best results for a balanced system are achieved by fitting appropriate flow restrictors to each hot and cold outlet. These MUST be fitted in cases where the final branch pipe sizes are not as recommended in item 4 or water pressures are above the recommended water pressure range of 2-3 bar. See Appendix B for details of suitable flow regulators.**
4. Alternatively the tee-offs to the outlets should be in 10mm except for the bath and showers which should be 15mm (1 metre minimum).
5. Alternatively, tee-offs to terminal fittings in existing property can easily be fitted with flow restrictors to balance the simultaneous demand.
6. The hot water supply to a shower mixing valve should be the first draw-off point on the circuit. The cold water supply to a shower mixing valve should be fed directly from the rising main and should be the first draw-off point on the cold circuit.
7. Typical cold and hot water distribution network is shown in Figures 9 and 10.

All the recommendations with regard to pipework systems in this manual are generally based on the use of BS/EN Standard copper pipework and fittings.

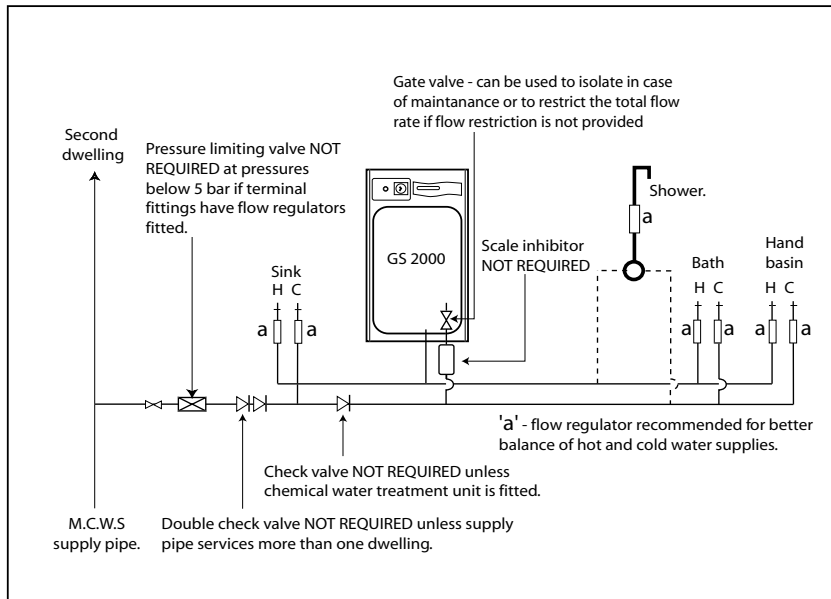

Figure 9 Hot & Cold Water Distribution Network

However, we are happy that plastic pipework systems can be used in place of copper internally as long as the chosen system is recommended for use on domestic hot and cold water systems by the manufacturer and is installed fully in accordance with their recommendations.

This is particularly important in relation to use of push fit connections when using the optional flexible hose kits see Installation & Wiring - 2. Fitting the Appliance.

It is also essential that if an alternative pipework material/system is chosen the manufacturer confirms that the design criteria of the new system is at least equivalent to the use of BS/EN Standard copper pipework and fittings.

2.4 Taps/Shower Fittings

Aerated taps are recommended to prevent splashing.

Any type of shower mixing valve can be used as long as both the hot and cold supplies are mains fed. However, all mains pressure systems are subject to dynamic changes particularly when other hot and cold taps/showers are opened and closed. To minimise the impact of this we would always recommend the use of thermostatic showers with this appliance.

The shower head provided must also be suitable for mains pressure supplies.

However, if it is proposed to use a 'whole body' or similar shower with a number of high flow/pressure outlets please discuss with the Gledhill technical department.

The hot water supply to a shower-mixing valve should be fed wherever practical directly from the GulfStream 2000 or be the first draw-off point on the hot circuit. The cold supply to a shower-mixing valve should wherever practical be fed directly from the rising mains via an independent branch. The shower must incorporate or be fitted with the necessary check valves to provide back-syphonage protection in accordance with the Water Regulations. The supply of hot and cold mains water directly to a bidet is permitted provided that it is of the over-rim flushing type and that a type 'A' air gap is incorporated.

2.5 Hot and Cold Water System

If the length of the hot water draw off pipework is excessive and the delivery time will be more than 60 seconds before hot water is available at the tap, you may wish to consider using trace heating to the hot water pipework such as the Raychem HWAT system. Please consult Gledhill technical department for further details.

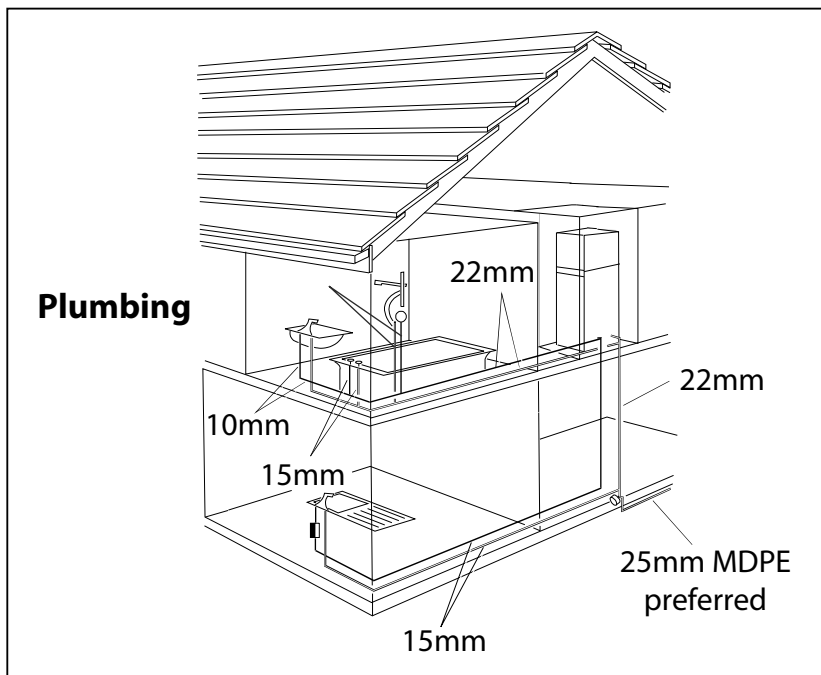

Figure 10

3. SPACE HEATING SYSTEM

3.1 General

All GulfStream models are available for both sealed and open vented heating systems

The design heat losses for the property will need to be calculated. We would recommend that the method for heat loss calculations, radiator and boiler sizing contained in BS 5449: 1990 is used and compared to the maximum central heating load listed in Technical Data on page 4. Allowances for domestic hot water requirements have been built into the difference between the nominal heat output and maximum central heating load figures shown on page 6:

If large baths or extra bathrooms are required please seek guidance from Technical Sales Department.

Note: A room thermostat and/or thermostatic radiator valves may be used: the former being wired directly to the boiler terminal strip - refer to Figures 29 and 30.

All the recommendations with regard to pipework systems in this manual are generally based on the use of BS/EN Standard copper pipework and fittings.

However, we are happy that plastic pipework systems can be used in place of copper internally as long as the chosen system is recommended for use on domestic heating systems by the manufacturer and is installed fully in accordance with their recommendations. We always recommend the use of barrier pipe for these systems.

It is also essential that if an alternative pipework material/system is chosen the manufacturer confirms that the design criteria of the new system is at least equivalent to the use of BS/EN Standard copper pipework and fittings.

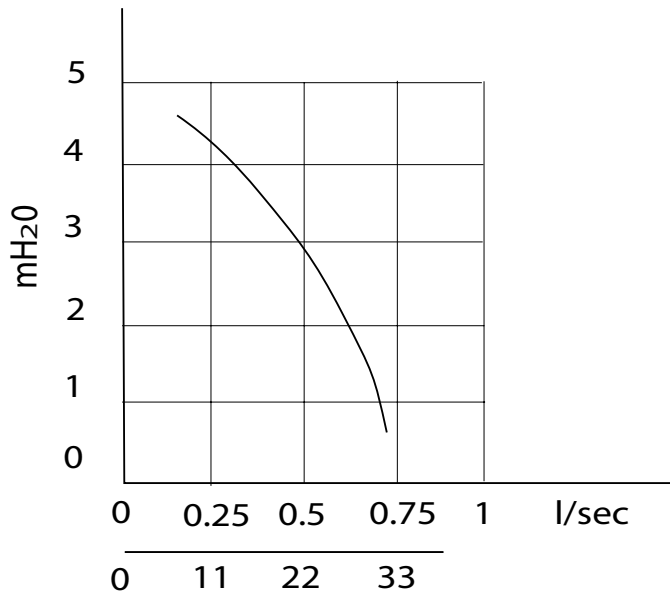

- * System load kW based on system ΔT of 11°C
Pump set at maximum
- * If head available is insufficient fit an additional system pump (2 pumps in series)

Figure 11 Pump Head Available for CH System

3.2 Heating System Design

3.2.1 General

The installation must comply with the requirement of BS 6798 and BS 5449. Maximum water temperature is $82 \pm 2^{\circ}\text{C}$. The appliance is supplied with the flow and return connections terminating in 22mm copper pipe or 22mm compression fittings.

The pump head available for the central heating circuit is shown in Figure 11.

The sealed system models incorporate the following components:-

- Heating pump - on the flow from the store.
- Expansion vessel - 12 litres, pre-charged to 1.0 bar.
- Pressure gauge 0 to 4 bar
- Expansion relief valve - set to operate at 3 bar.

At least one flushing valve should be fitted at the lowest point in the system to enable the water system to be drained.

If the appliance is the highest point on the heating system a manual air vent is provided above the heating pump. However, if any point of the heating system is higher than the appliance we would recommend that an automatic air vent is fitted at the highest point in the system.

Normal procedures for sizing heating circuit pipes should be used and the pump head available for the heating system is shown in Figure 11. If all the radiators are provided with thermostatic valves a suitable by-pass should be provided as normal on the heating circuit.

3.2.2 Sealed Central Heating System

The sealed heating system/appliance must only be filled by a competent person. Full details are provided in Appendix A - Design/Installation details for the CA type backflow prevention valve assembly and anti-vacuum valve.

Note: Minimum of 2 bar mains pressure must always be available for correct operation of CA devices.

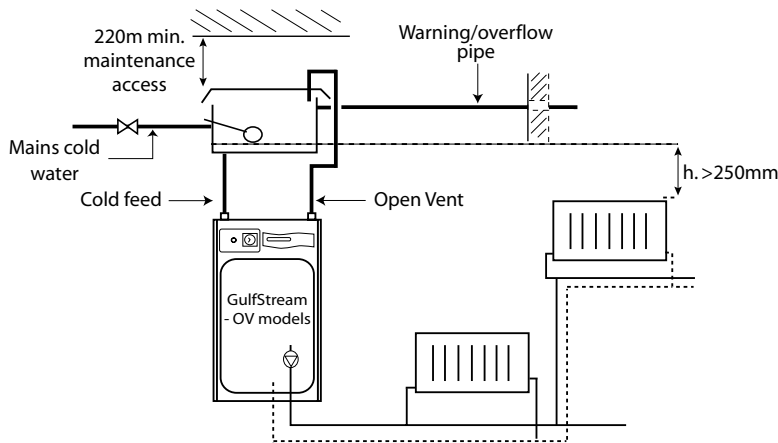

Figure 12 Schematic layout of the open vented heating system

In normal circumstances a pressure of 1.0 bar is suitable for most domestic properties.

The minimum system pressure should be not less than the static head, (the height of the highest point in the system above the expansion vessel plus a margin of 0.5 bar).

Expansion Vessel

The appliance is supplied with a 12 litre expansion vessel pre-charged to 1.0 bar. The expansion vessel has to be suitable to accommodate the change in volume of the water in the system when heated between 10°C to 110°C. See BS 5449: 1990 clause 16.2 for further information.

NOTE: After first filling the system to a pressure of 1.0 bar at mains supply temperature (typically around 15°C in summer), the unit should be switched on, and the GulfStream²⁰⁰⁰ should be heated to its maximum temperature. If the pressure gauge then indicates 2.6 bar or higher, an additional expansion vessel may be required in the system. Expansion vessel requirements are shown in Table 3.

3.2.3 Open Vented Central Heating System

The '-OV' models the GulfStream 2000 are only suitable for an open vented system shown schematically in Figure 12.

The F & E cistern can be fitted up to 10m above the base of the appliance i.e. the maximum static pressure in the appliance must not exceed 1 bar.

The water level in the F & E cistern should be at least 250mm above the highest point on the system including the radiators.

The overflow/warning pipe should be in a 20mm internal diameter pipe of suitable material for use with a heating F & E cistern, in accordance with BS 5449 (such as copper). It should have continuous fall and discharge in a conspicuous external position.

The cold feed pipe should be in 15mm overall diameter copper tube or equivalent and the open vent should be in 22mm copper or equivalent.

TABLE 3 EXPANSION VESSEL REQUIREMENTS

TABLE 3 EXPANSION VESSEL REQUIREMENTS			
Vessel Charge	bar	1	1.5
	psi	14.5	21.8
Total water content of system, including the store using 12 litre (2.6 gal) capacity expansion vessel supplied with appliance	litre	110	76
	gal	24	17
For systems having a larger capacity multiply the total system capacity in litres (gallons) by the factor to obtain the total minimum expansion vessel capacity required litres (gallons)		0.11	0.16

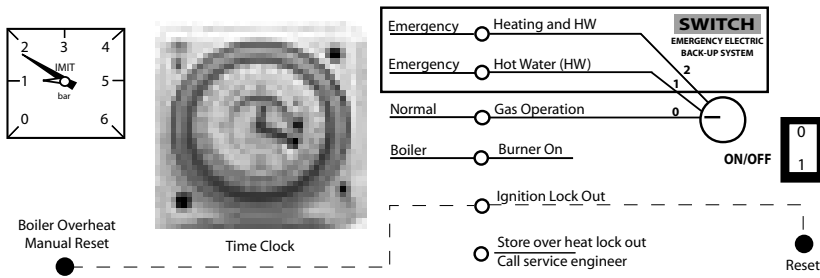

Figure 13 Panel for models 2000/120/E and 2000/130/E

3.3 Heating System Controls

Both the open vented and the sealed system models are fitted with the 'Switch' electric back-up system. This allows the user the choice of natural gas for normal operation and back-up electrical energy in an emergency.

The control panel of sealed system models 2000/120/E and 2000/130/E is shown in figure 13.

The control panel of open vented system models 2000/120/E-OV and 2000/130/E-OV is shown in figure 14.

A room thermostat and/or thermostatic radiator valves may also be fitted to control the central heating requirements.

If the appliance is sited in an unheated space (e.g. a garage, out house, ventilated roof space) then a frost thermostat must be fitted to protect the appliance and the heating system. The details are given in the electrical section

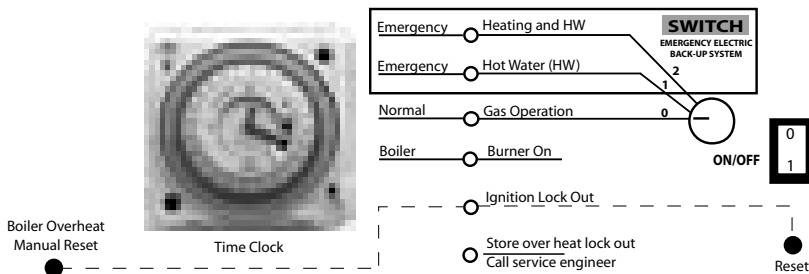

Figure 14 Panel for models 2000/120/E-OV and 2000/130/E-OV

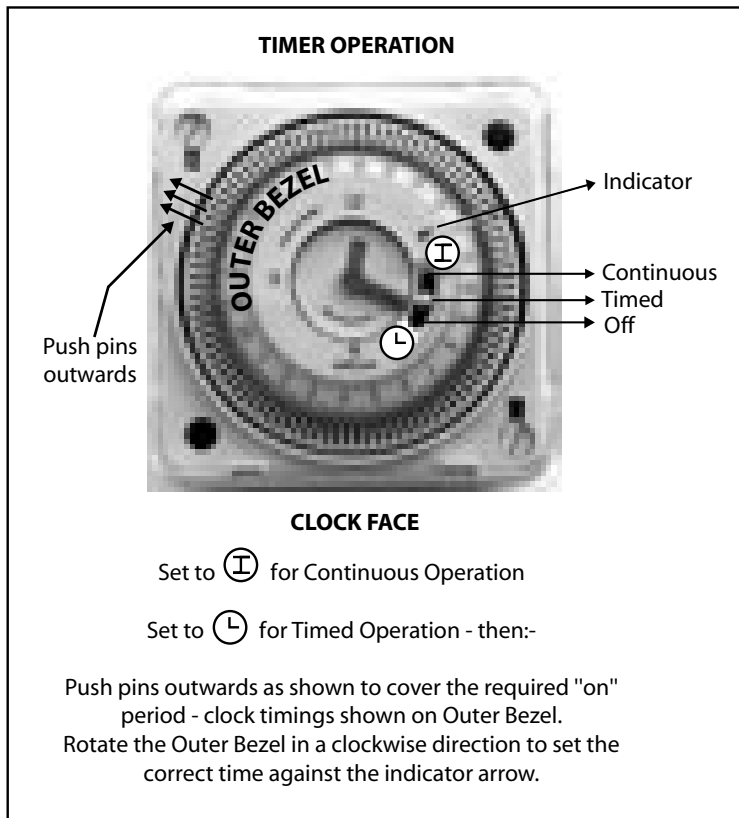

Figure 15

FLUE SYSTEM DESIGN

1. GENERAL REQUIREMENTS

A full range of flue options are available for the GulfStream 2000 and details can be found in the following separate Design & Installation Manuals.

1. Ridge Terminal Flue Kit
2. Gable Terminal Flue Kit
3. Balanced Flue Terminal Kit
4. Twin Pipe Horizontal Flue Kit
5. Roof Terminal Flue Kit

This appliance must only be installed using one of the above approved flue kits.

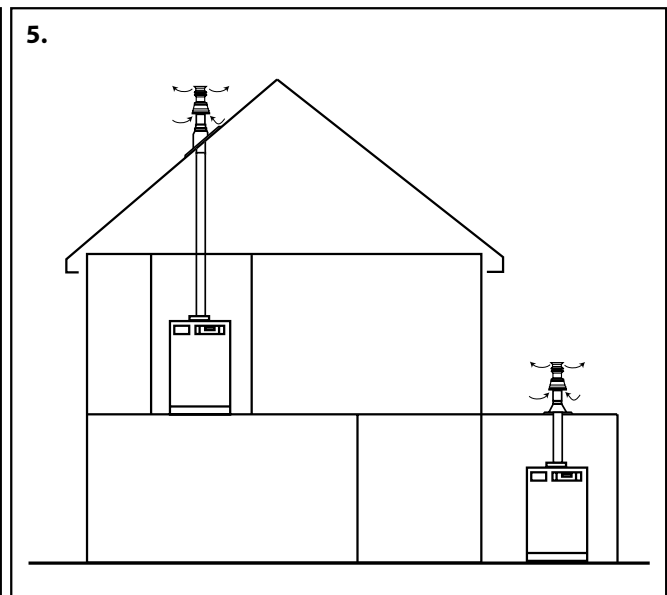
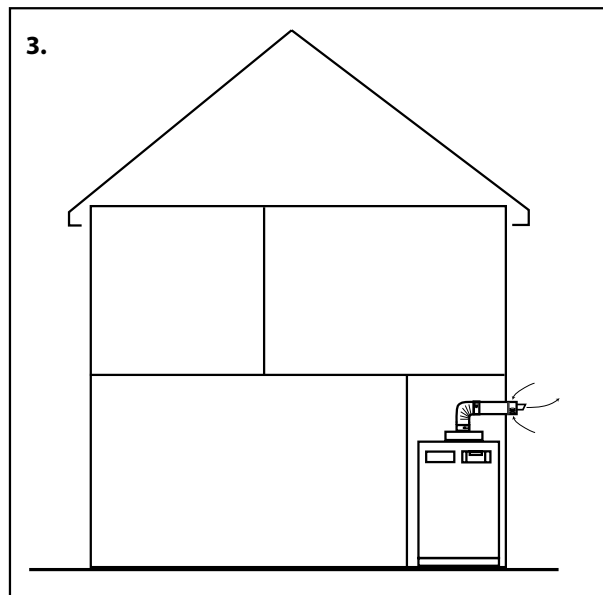
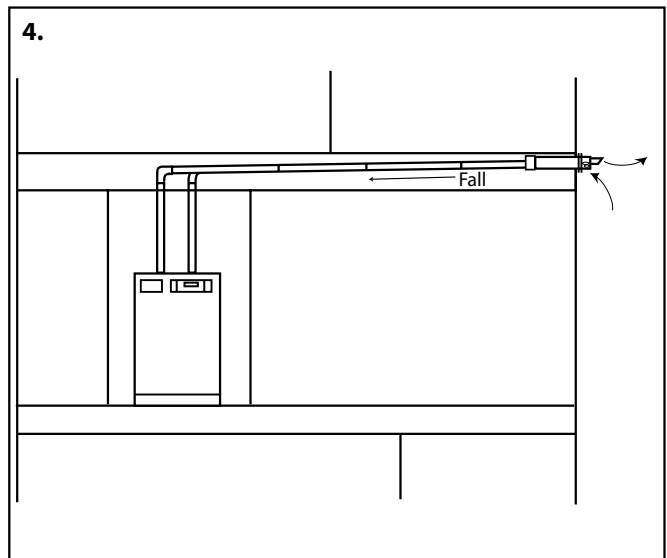
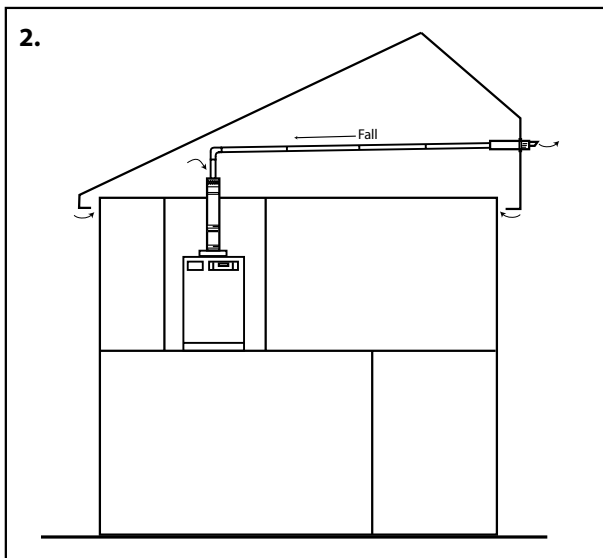
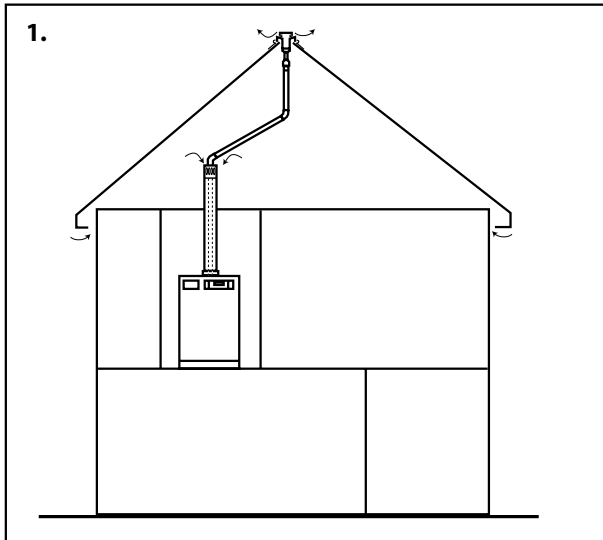

INSTALLATION & WIRING

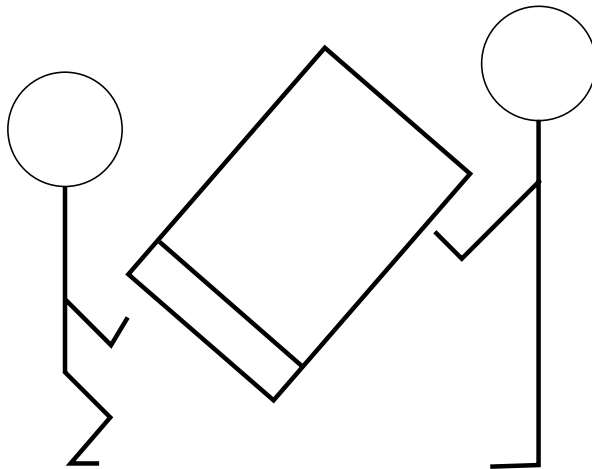

1. HANDLING/STORING THE APPLIANCE

1.1 The appliance should be handled carefully to avoid damage and the recommended method is shown opposite.

Team Lifts.

When lifting the unit work with someone of similar build and height if possible.

Choose one person to call the signals.

Lift from the hips at the same time, then raise the unit to the desired level.

Move smoothly in unison.

1.2 The appliance is supplied shrink wrapped on a timber installation base. Carrying handles are also provided in the back of the casing.

1.3 If the unit needs to be stored prior to installation it should be stored upright in a dry environment and on a level base/floor.

2. FITTING THE APPLIANCE

2.1 General

The appliance should be mounted on a 100mm high plinth supplied with the appliance to facilitate the pipework connections at the front of the appliance.

When using push fit connectors with the flexible hose kits it is important to check that they are compatible.

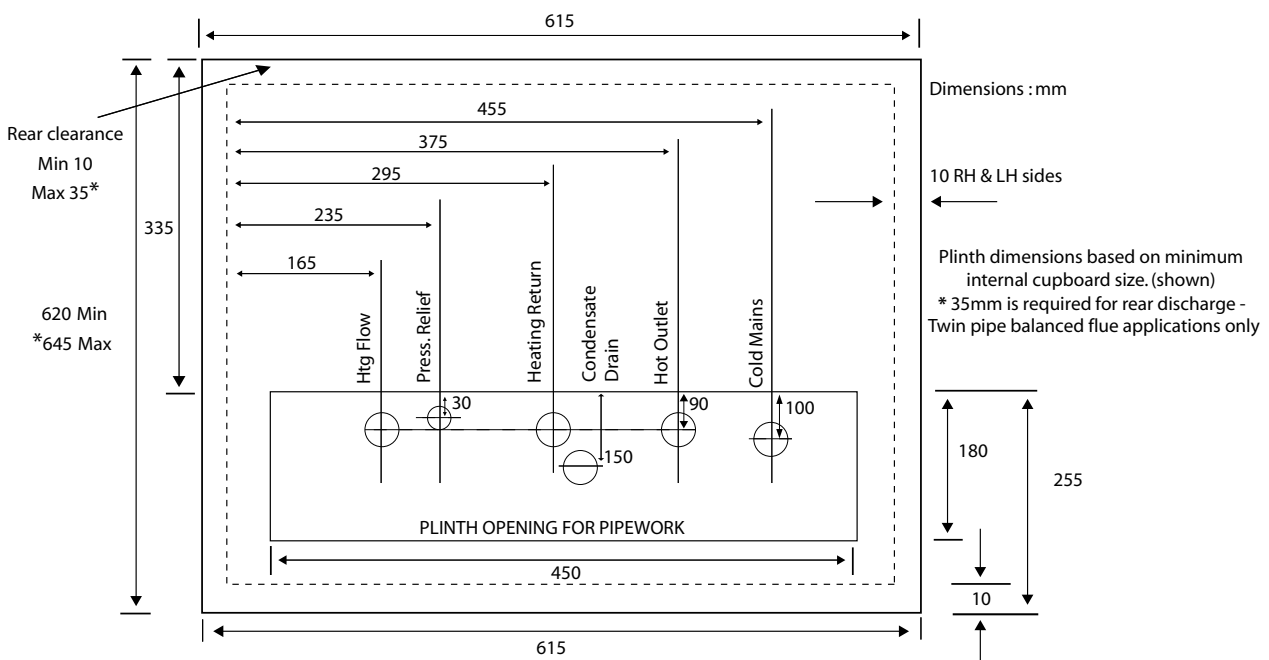
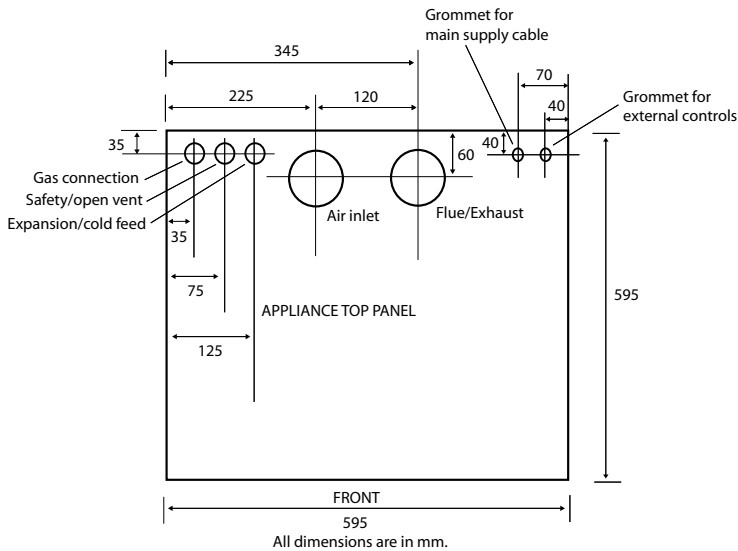

Figure 17

Written approval has already been obtained for:
Hepworth - Hep₂O BiTite
John Guest - Speedfit
Yorkshire - Tectite

However, as similar assurances cannot be obtained for Polypipe fittings we cannot recommend their use.

All the water connections, apart from make-up tank and cold feed, are located at the bottom front of the appliance. The gas connection, electricity supply cable entry, along with the make-up tank and cold feed connections, are located at the top of the appliance (see Figure 17).

2.2 Central heating and domestic hot water

Using 22mm copper pipework connect the appliance to the central heating and secondary DHW. Stop valves should be fitted as close to both appliance connections as possible. Both CH and DHW appliance connections are clearly labelled.

2.3 Expansion relief valve (sealed system models)

The valve should be installed into a discharge pipe which permits the safe discharge of steam and hot water such that no hazard to persons or damage to electrical components is caused.

NOTE:- The valve incorporates plastic components which will be adversely affected by heat. For this reason we recommend the use of compression fittings for joints to the valve and adjacent to the valve.

2.4 Drain cock

A ½" drain cock supplied with the appliance should be fitted to the drain connection on the appliance using an approved jointing compound.

2.5 Gas

Connection is made at the top rear of the casing. The union gas cock is supplied as a loose item in the fitting kit. The male liner, with union nut, should be fitted to the Rc ½" gas inlet using an approved jointing compound. The gas cock can then be fitted and the gas supply completed. The whole gas installation including the meter should be inspected and tested for soundness and purged in accordance with the recommendations of the current issue of BS 6891.

2.6 Condensate drain

- Connect the condensate trap to a suitable plastic drain pipe i.e. PVC, UPVC, ABS or PP which must have a minimum internal diameter of 15mm inside the building and 32mm internal diameter outside the building. Any external pipework should be kept to a minimum length to minimise the risks of freezing.
- The pipe should not have any upward pipe runs and must fall at least 2.5° (1:20) throughout its length towards the discharge point.
- It must be safely terminated in a permanent drain. This may be an internal soil stack or waste pipe, an external gulley hopper or soakaway and may require the use of a trap or break.

Note that condensate will be slightly acidic providing that the instructions above are followed no special provision is necessary normally. (Refer to figures 4 and 5).

The position chosen for the discharge must ensure no damage as a result of condensate release. It should be protected from blockage by debris or frost. Any local building control authority requirements must be complied with.

Note that if a condensate neutraliser is fitted it must be installed and maintained strictly in accordance with the manufacturers instructions. However, if the installation instructions for the boiler and neutraliser are contradictory seek advice from both manufacturers before installation.

2.7 Access to the appliance

To gain access to all components refer to figures 4, 5, and 18.

First remove the front panel by unscrewing the two retaining screws at the top front LH and RH sides. Lift the panel slightly and swing it forward from the top. Lift the panel to disengage it from the bottom edge. Remove the top panel by unscrewing the screws at the LH and RH sides.

2.8 Feed and expansion cistern

The feed and expansion cistern support shall be installed ensuring that the base is fully supported and the working head (10m) of the appliance is not exceeded.

The adequate access must be provided for maintenance of the F & E cistern.

INSTALLATION & WIRING

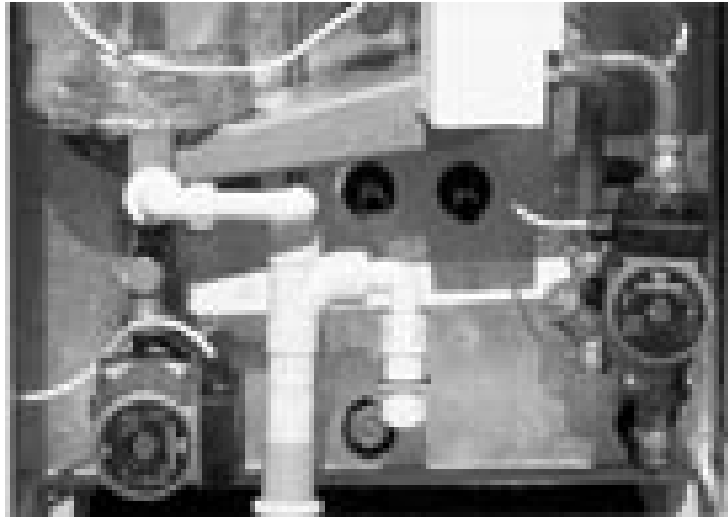

Figure 18

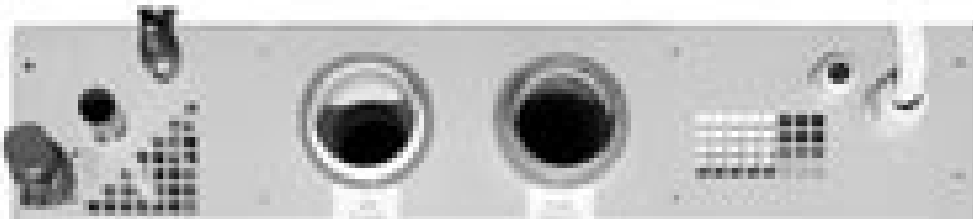

Figure 19

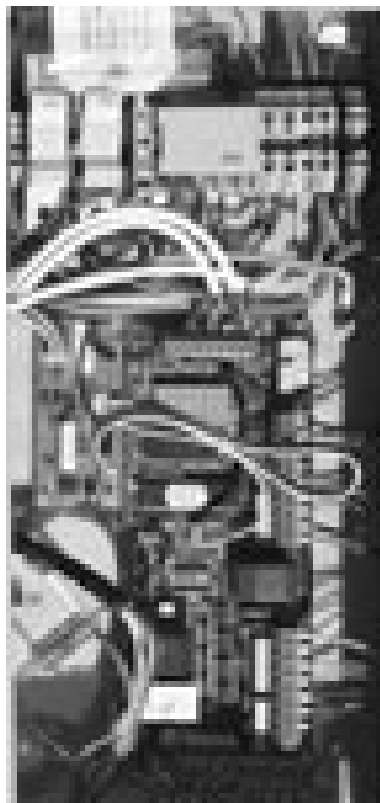

Figure 20

INSTALLATION & WIRING

3. ELECTRICAL WIRING

3.1 General Requirements

NOTE: THIS APPLIANCE MUST BE EARTHED.
Refer to Figures 20, 21 and 22 as applicable.

Thread the power supply cable through the larger of the cable restraining glands positioned at the top rear RHS of the casing.

Feed the cable forward and make the required connection to the terminal strip.

IMPORTANT NOTE:- ENSURE WIRING SPECIFICATION IS COMPATIBLE WITH MODEL BEING FITTED.

Tighten down the cable restraining gland making sure the earth lead is longer than either LIVE or NEUTRAL.

External controls wiring for the gas boiler, e.g. room thermostat fixing, should pass through the smaller of the cable restraints and the necessary connections made to the terminal strip. Tighten down the cable gland at the entry to the appliance.

All electrical wiring to the appliance should be secured to prevent the wire touching any hot surfaces on the boiler.

The electrical installation must comply with the latest I.E.E. Wiring Regulations.

After installation of the appliance, preliminary electrical systems checks must be carried out i.e. earth continuity polarity and resistance to earth short circuit.

On completion of the electrical installation the control box cover should be re-fitted and the casing lower panel re-assembled.

DO NOT SWITCH ON THE ELECTRICITY SUPPLY AT THIS STAGE.

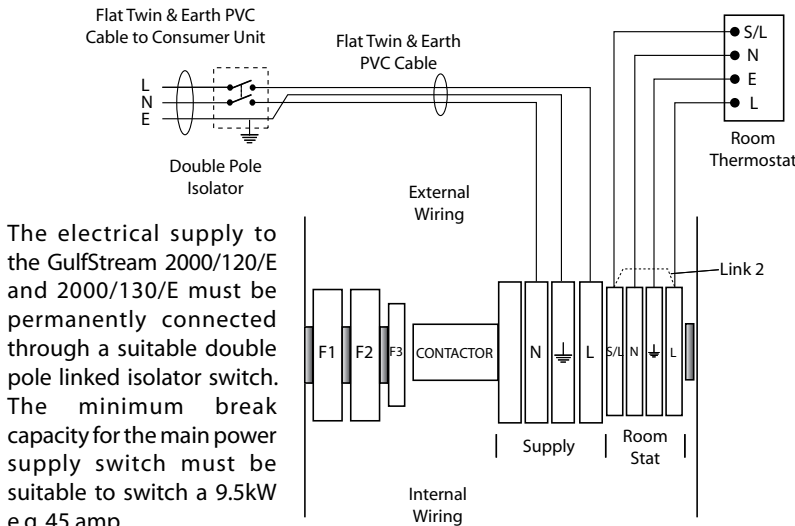

The electrical supply to the GulfStream 2000/120/E and 2000/130/E must be permanently connected through a suitable double pole linked isolator switch. The minimum break capacity for the main power supply switch must be suitable to switch a 9.5kW e.g. 45 amp.

F1, F2: 25 amp fuses

F3: 5 amp fuse

Figure 21 External Wiring for all Models

Wiring Specification and General Guide		All electrical work must comply with the IEE Requirement for Electrical Installations (BS 7671). If the responsibility of the competent Electrical Installer to use the details below in conjunction with the latest British Standards.		
kW Rating @ 230V + 10%/ -6%	Nominal current @ 230V (amps)	Min. rating of isolating switch @ 230V (amps)	Max. cable run based on 9.2V drop and earth fault loop impedance for 0.4s disconnection time. Also using type 1 & B Protecton devices.	
9.0kW Heating Load 500W Auxillary Load Pumps control circuit etc. Models 2000/120/E, /120/E-OV, /130/E, 130/E-OV	41.30 amps	45 amp	NOT PERMISSABLE	49
9.5Kw Thermal Storage Appliance recommended C.P.D. (circuit protection device) to ensure a 0.4 sec. disconnection time under fault conditions.		45A type 1 mcb to 45A type B circuit breaker to 50A type 1 mcb to 50A type B circuit breaker to	BS 3871 BS EN 60898 ***Provides best protection BS 3871 BS EN 60898	

INSTALLATION & WIRING

3.2 External controls

• Room Thermostat

- Remove link 'L1' joining 'red' and 'black' terminal block in the appliance wiring panel.
- From the room thermostat connect switched live to black terminal.
- From the appliance 'red' terminal take a 'live' to 'live' connection on the room thermostat.
- From the appliance 'blue' and 'green/yellow' terminals take 'neutral' and 'earth' to 'neutral' and 'earth' on the room thermostat respectively.

3.3 Frost Protection

If a frost thermostat is fitted then it should be wired as shown in Figure 22.

The frost thermostat will then override both the programmer and room thermostat and switch on heating and boiler until the frost stat is satisfied.

NOTE: For the frost thermostat to work the appliance must be left switched on.

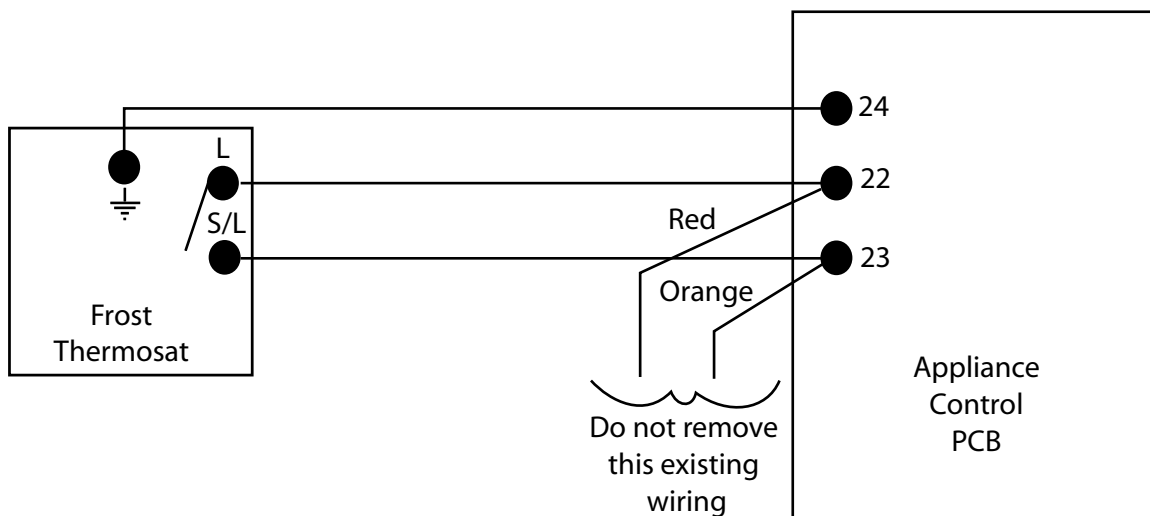

Figure 22 Frost Thermostat Wiring

1. GENERAL

It is essential that all systems function properly for optimum performance. To achieve this the primary system should be commissioned in accordance with good practice and generally in accordance with the requirements of BS 6798, BS 5449 and BS 7593.

Full details of the requirements are given in PAS 33:1999 under Section 10 Commissioning.

2. INITIAL SYSTEM FILLING

Experience with sealed systems shows that make up may be needed during the first six weeks of operation.

If draining down is necessary, first release any internal pressure by opening the pressure relief valve, then after ensuring all system and boiler vents are open, open the drain valve.

Open the CH flow and CH return valves.

Check and adjust the expansion vessel air pressure if necessary to the initial charge pressure (1.0 bar).

The approved method of filling the sealed heating system/appliance is described in section 3.2, page 14.

Fill the open vented system in the normal way through the feed and expansion cistern. If the system fails to fill easily release the air vent on the cold feed connection on top of the appliance until all the air is released. When the system is full check the water level in the F & E cistern is correct and regulate the servicing valve so that in a fault condition the warning/overflow pipe can carry the maximum water supply rate.

Vent the system via the appliance's automatic air vents and the radiator valves and system air vents in accordance with normal practice.

Open the cold water inlet cock and allow water to flow through the appliance to the domestic hot water taps. Ensure all air is vented and there are no leaks.

3. CLEANSING AND WATER TREATMENT

The water system must be thoroughly flushed out, initially with cold water and ensuring that all valves are fully open.

The correct use of a cleaning agent and addition of the correct strength of a suitable corrosion inhibitor is essential for the efficient and long life of the GulfStream 2000 appliance. For this reason we have extensively tested and would recommend the use of the following Fernox products only for use with the GulfStream 2000 appliance.

Refill the system and pressurise it to normal working pressure and examine for water leaks. Rectify if necessary and then add Fernox Superfloc Cleaning Agent to ensure that all flux residues and installation debris are removed from the system.

Heat the system to full operating temperature and check for water leaks and rectify if necessary. Flush the system again until the system is clean.

Refill the system and add Fernox MBI Protector to the system ensuring that the system is fully vented.

Ensure that the water level in the F & E cistern is at correct level in open vented system models designated by '-OV'.

Ensure that the sealed system is pressurised to 1.0 bar.

When determining the quantities of cleanser and corrosion inhibitor agent required, be sure to allow for the increased volume of water in the primary circuit (70 litres) due to the thermal store.

It is important when chemically cleansing and treating the system that this is carried out fully in accordance with the instructions of the manufacturer of the product being used.

WARNING: The aluminium waterways of the GulfStream 2000 boiler require the pH level of the water to be maintained between 7 and 8 to ensure long life. This level will automatically be provided by the Fernox MBI corrosion inhibitor if the correct concentration is used. However, dependent on the quality of the water being used, failure to dose/maintain the correct concentration will result in premature corrosion of the boiler.

With an open vented system, once the system is finally filled, turn down the servicing valve to the ballvalve in the F & E cistern to the point where the warning/overflow pipe will cope with the discharge arising from a ballvalve failure.

POWERFLUSHING/CLEANING OF THE HEATING SYSTEM

If it is proposed to 'powerflush' the heating system we would recommend that the GulfStream appliance is isolated from the heating system being cleaned. Failure to do this could seriously damage the appliance.

When carrying out the work always comply fully with the manufacturers instructions for the powerflushing equipment being used.

If in any doubt please consult our Technical Helpline.

4. FLUE AND AIR PIPES

The flue/air pipe systems should have been designed and installed in accordance with the requirements under 'Flue System Design' in this literature.

Concentrate particularly on the integrity of the joints and the sealing of terminal(s) and pipes, as applicable. Check that horizontal lengths of flue pipe fall back to the boiler with no low points to trap condensate. This is an important procedure as incorrectly installed flue systems can lead to potentially dangerous situations.

5. INITIAL LIGHTING



Check that the electricity supply is ISOLATED and the selection knob (fascia panel) is set to 'Normal Gas Operation'. Ensure that the boiler and system are full of water by checking the vent points on the boiler and the system charge pressure.

Turn on the gas supply and open the gas service cock to purge air from the gas line in accordance with the current issue of BS 6891.

Turn off the gas supply at the appliance and undertake a dry run to lockout as follows:-

Check that all manually reset thermostats have been reset and are not open circuit.

The appliance PCB (figure 23) indicates the operation of the system which must be checked and initialised as follows:

1. Switch off heating on the clock/programmer and room thermostat.
2. Switch off hot water on the programmer if 2 channel remote clock is fitted.
3. **Check the jumper settings are correct. These must all be in the correct positions for the appliance to work correctly see figure 23 below for details.**
4. Switch on the mains supply. The A.C.B. will automatically commission itself and the dot after the  ON the display will flash. e.g. 

The control system is now initialised. The operation of the controls can now be checked.

1. Horizontal LED BAR 2 'ST' will be lit.
Boiler, boiler pump and boiler fan will be running and green LED's 1, 2 and 4 on the PCB will be switched on.

Note: The controls within the PCB will not allow the heating system to function until the store temperature has reached 64°C. Therefore although the LED bar 1 'HT' will light when heating is switched on, the heating pump (Green LED -3) will not switch on if the store temperature is less than 60°C. Time will need to be allowed for this to happen during initial commissioning.

Check that the appliance circulation pump is circulating water through the boiler and store.

The boiler 'Normal Gas Operation' indicator light should illuminate (green) and the fan will start running.

After a few seconds the solenoid valve will open the intermittent spark will commence but as the gas is turned off the full sequential control system will then go to lockout and the red lockout indicator light will be illuminated (Figures 13 & 14). Turn off the external electrical supply. Carry out the ignition sequence with live gas ONLY if the safety system has operated correctly.

Turn on the gas supply at the appliance. Switch on the external electrical supply.

Reset the switch on the control panel (Figures 13 & 14) before the fan should run - followed by the gas solenoid opening. The spark ignitor should ignite the burner (visible through the site glass) and the burner should remain at low rate for around 30 seconds. Also burner on indicator light in yellow will illuminate on front panel. The burner should then increase to maximum (high) rate. This is signalled by a noticeable increase in fan speed and burner flame size.

The remaining system functions can now be checked.

2. Once a temperature of 64°C has been reached on the thermal store, switch on space heating clock/programmer and room thermostat.
 - Horizontal LED bar 1 'HT' will light.
 - Green LED 3 on the A.C.B will switch on. Heating pump will run.

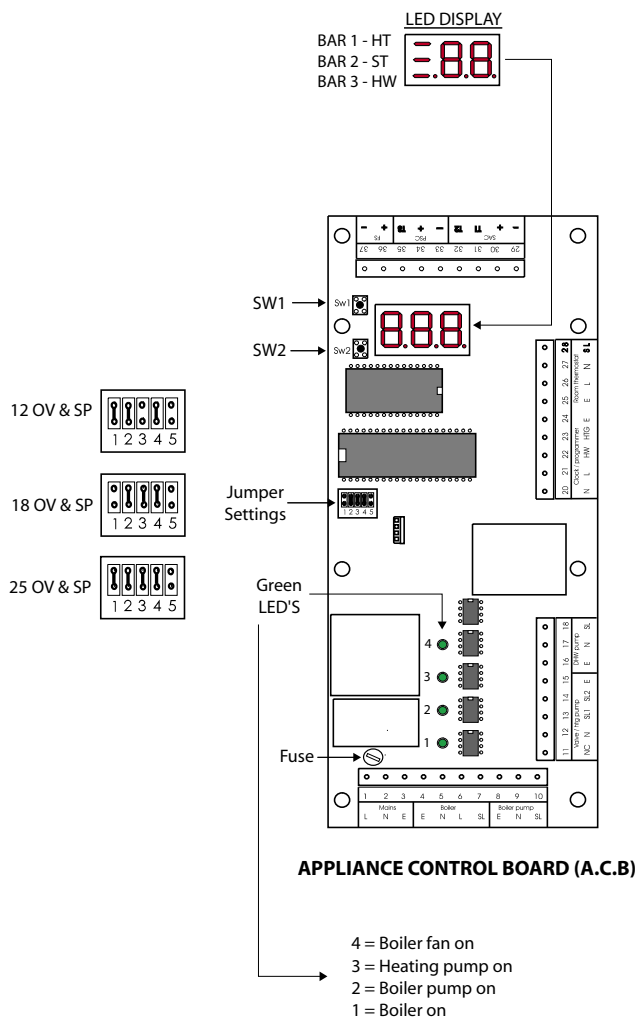

Figure 23

COMMISSIONING

3. Switch off space heating on clock/programmer or room thermostat
 - Horizontal LED bar 1 'HT' will switch off.
 - Green LED 3 on the A.C.B. will switch off.
 - Heating pump will switch off.
4. Open the hot tap
 - Horizontal LED bar 3 'HW' on the LED display will light.
 - Domestic hot water pump will run.
5. Close the hot water tap
 - Horizontal LED bar 3 will remain alight for a short period of time before switching off.
 - Domestic hot water pump will continue to run for a short period of time before switching off.
6. The A.C.B incorporates a 3 minute pump overrun facility for the boiler. Check green LED 2 remains lit for this period of time when the boiler switches off i.e. the thermal store reaches temperature.
7. Instruction to Users.
 - Explain the system to the occupant.
 - Instruct how to operate and control the space heating, i.e. time clock and room stat.
 - Instruct the occupant to have the system checked annually by a qualified engineer.

The control functions have now been checked. Let the boiler heat the store and when the store is satisfied, i.e. green LED's 1 and 2 on the A.C.B are off, the radiator circuit and hot water can be checked and balanced in the normal way.

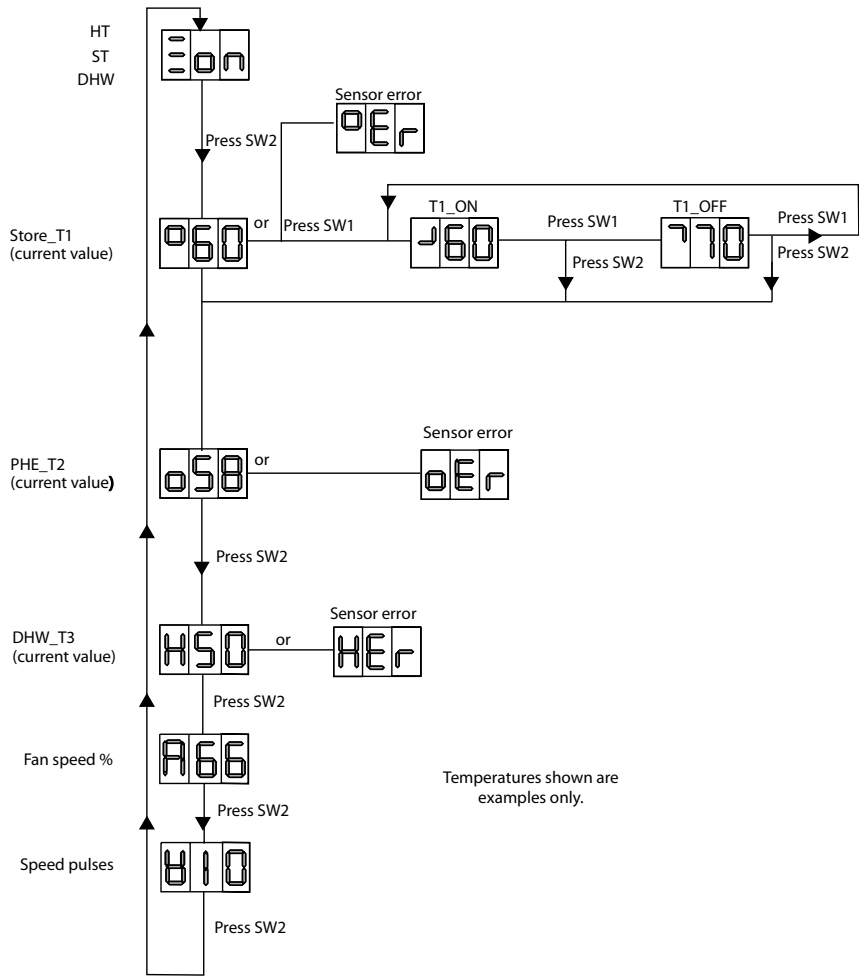

Figure 24

7. PROCEDURE FOR CHECKING AND ADJUSTING GAS RATE AND BURNER PRESSURE (OFFSET)

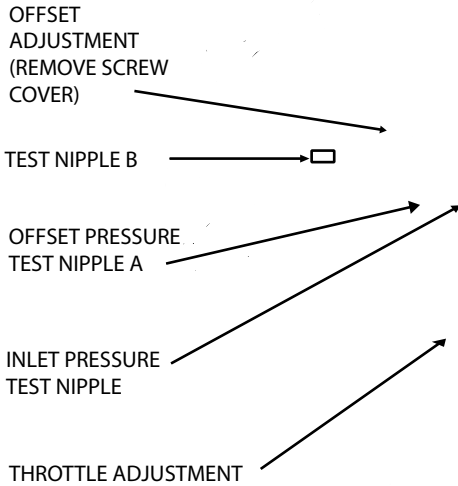

Figure 25 Honeywell MFC and Venturi Sub-Assembly (Refer to Figure 43 also)

To check and if necessary adjust the burner pressure (offset), CO and CO₂ levels, the following equipment will be required:

A portable gas analyser - CO₂ range 12% maximum - CO range 500ppm.

A vertical manometer (U gauge) - range 30mbar minimum.

An inclined or electronic micromanometer - range ± 100 Pa (± 1.0 mbar) maximum. in addition to set up the equipment a metal or plastic T piece and a length of sensing line will be required.

Refer to figures 25 and 26.

Note:

1. The inclined or electronic micromanometer shall be capable of being read to 1 pascal (0.01 mbar).
2. The inlet pressure test nipple and offset pressure test nipple A are opened by turning the sealing screw once in a counter clockwise direction.
3. A minimum dynamic inlet pressure (boiler running) of 15mbar is necessary at the inlet test nipple.
4. Counter clockwise adjustment ($\frac{1}{4}$ turn max. at each attempt) of the throttle will increase gas in and out hence CO₂ level. Throttle adjustment usually results in small, if any, change in offset reading.
5. The final offset reading MUST always be NEGATIVE.
6. Counter clockwise adjustment ($\frac{1}{4}$ turn max. at each attempt) of the offset will cause it to become more negative.

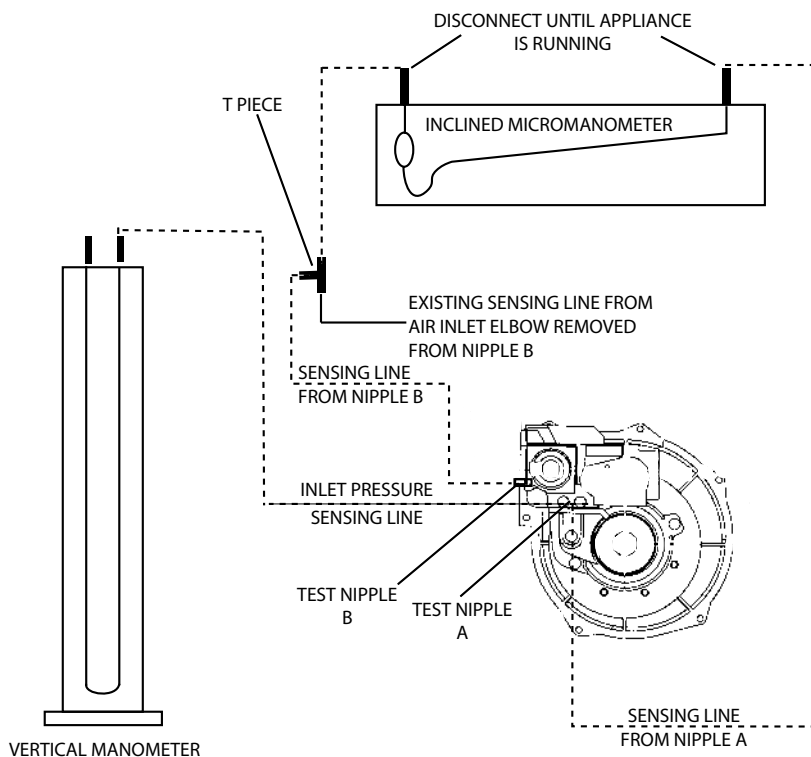

Figure 26

IMPORTANT:

Test nipple B is connected via a permanent sensing line to a nipple located in the elbow below the air pipe inlet and it senses air inlet suction which is the MINIMUM suction value.

Test nipple A is, when opened to atmosphere, under MAXIMUM suction. When the nipples are connected correctly as described below the suction at B is subtracted from the suction at A and will result in a negative suction reading on the instrument.

Correct readings are as follows:-

Reference	Models	Offset Pressure (pascals)	Fan Speed %	CO ppm	CO ₂ %
12 OV & SP	GC2000/120/E GC2000/120/E-OV	(-10 / -12)	68	Less than 100	9.3 to 9.6
18 OV & SP	GC2000/130/E GC2000/130/E-OV	(-18 / -20)	96	Less than 100	9.3 to 9.6
25 OV & SP	GC2000/130/E GC2000/130/E-OV	(-18 / -20)	98	Less than 100	9.3 to 9.6

CO₂ operation at slightly higher level (upto 9.8% is satisfactory provided 0.01% CO is not exceeded).

Proceed as follows:

- Turn off the electrical supply and gas supply. Ensure manometers are set to zero refer to Figure 25 and Figure 26.
- Open the inlet pressure test nipple and connect a sensing line from it to the vertical manometer.
- Remove the existing sensing line from nipple B and connect it to the T Piece. Run a new line from the T to nipple B. Connect the remaining open outlet from the T to the MINIMUM section side of the micromanometer - as shown.
- Open nipple A and run a sensing line from it to the MAXIMUM suction side of the micromanometer.
- Before relighting the appliance, disconnect the sensing lines at the micromanometer and (temporarily) join the ends with a solid dowel. Excessive fan suction during pre-purge may draw fluid into the sensing lines if they are left connected at this stage.
- Connect the flue gas analyser to the flue gas sample point at the bottom of the appliance (figure 4) . Turn on the gas and electrical supplies. Allow the appliance to ignite and run for about 10 minutes. Meanwhile reconnect the micromanometer.
- Ensure the appliance is running continuously at maximum output (fan speed 98% for 25 model, 96% for 18 model and fan speed 68% for 12 model). After 10 minutes note the CO and CO₂ and offset readings and adjust to the figures in the table above. Then ensure the CO and CO₂ readings reduce as the appliance modulates down i.e. fan speed reduces - this ensures the offset has been correctly set.
- When the readings are satisfactory turn off gas and electricity supplies. Remove/disconnect equipment and ensure all pressure test points are closed and caps fitted over are sealed.
- Re-fit all sensing lines correctly.
- Undertake a gas soundness check.

8. FINAL ADJUSTMENTS

- Re-light the appliance and allow the thermal store to heat to maximum. Check for water leaks, turn the boiler off, drain the system whilst hot.
- If an in line water strainer, is fitted, it should now be checked and cleaned if necessary. The strainer is situated in the inlet to the cold feed compression joint.
- Refill the system and adjust to the system fill pressure (1.2 bar). Check the pressure gauge pointer is set to the system design pressure. Check all air is vented from the system.
- Re-light the appliance and allow the thermal store to heat to maximum.
- To check the operation of the domestic hot water supply, open a domestic hot water tap and ensure that hot water is satisfactory, i.e. the flow and temperature are in accordance with TECHNICAL DATA. Turn off the tap. To check the operation of the central heating, ensure all the external controls (should they be fitted) are calling for heat, switch the time clock over-ride switch to the 'ON' position. The central heating pump will come on and distribute the stored water around the central heating system. The thermal store temperature control may fire the boiler to replenish the store. Balance the heating circuits as normal practice. Switch the time clock over-ride switch to 'OFF'.
- Set the time clock switch to the timed position and check that the clock is set at the desired time periods. Set the room thermostat (if fitted) to the required setting.
- Instruct the User on the correct operation of the appliance and any system controls if fitted. Ensure the User is fully conversant with all aspects of boiler and system operation.

IMPORTANT:- THE USER MUST BE INFORMED NOT TO TAMPER WITH THE APPLIANCE OR TO BREAK ANY SEALS ON THE PRESET CONTROLS OF THE APPLIANCE.

9. EXTERNAL CONTROLS

Check that any other external controls connected in the system such as time clocks and thermostats, control the boiler as required.

Explain and instruct the occupants on how to use the system.

USER INSTRUCTIONS

User's Instructions are provided on the front of this appliance and also a separate user booklet is also packed with the appliance.

Your GulfStream 2000 has been designed to operate at its most efficient when left ON DEMAND at all times.

The time clock and room thermostat, as in a traditional system, controls the central heating.

LIGHTING INSTRUCTIONS

1. Turn on the gas and electrical supplies to the appliance.
2. Ensure the appliance is switched ON.
3. Ensure all external controls are set to the ON position.

LIGHTING SEQUENCE

1. The appliance fan will start.
2. After a short period the ignition sparking will commence.
3. The main burner will light.
4. Indication of the appliance status is shown on the fascia panel.

HEATING/HOT WATER FAILURE

If the boiler does not fire and the heating and/or hot water is lost first check:

1. That the room thermostat is set high enough.
2. That the time clock is in an ON period.
3. That power is being provided - indicated by the green 'ON' light, and that the gas supply is available.
4. That the primary water pressure is between 1 and 2 bars.
5. That the automatic air vent on the top of the appliance is not screwed down.
6. That the ignition reset button (ignition lockout indicator light on) does not require resetting.
7. That the boiler overheat reset button does not require resetting (under black cap).

IF EITHER RESET BUTTON REQUIRES RESETTING, PRESS IN ONCE OR TWICE. IF THE APPLIANCE DOES NOT UNLOCK WAIT 15 SECONDS AND TRY AGAIN. IN CERTAIN CIRCUMSTANCES LOCK OUTS MAY OCCUR, IT IS ONLY NECESSARY TO CALL AN ENGINEER IF THIS HAPPENS ON A REGULAR BASIS.

EMERGENCY SHUTDOWN

1. Turn off the electrical supply to the appliance at the fused isolator switch.
2. Turn off the gas to the appliance at the gas meter.

CLOCK INSTRUCTIONS

The clock can be set as follows:

COARSE ADJUSTMENT: Rotate the outer (24hr) dial clockwise until the stationary marker arrow is almost opposite the current time.

FINE ADJUSTMENT: Rotate the minute hand in a clockwise direction to accurate time.

TO SELECT THE 'ON' PERIOD(S) REQUIRED: Push the appropriate tappets surrounding the 24 hr dial to their outer position.

MANUAL OVERRIDE (located between 3 & 4 p.m., on the inner dial)

Upper position: permanently 'ON'

Centre position: time controlled 'ON' and 'OFF'

Lower position: permanently 'OFF'

Hot water is not time controlled and is available at all times.

SWITCH

This unit is fitted with 'Switch' which provides an emergency electric back-up system, for heating and hot water in the heating season or hot water only in the summer. **It should only be left in this mode until a service engineer is called since there is no temperature control to the domestic hot water and care should be taken when putting hands directly under taps.**

TO ACTIVATE, SWITCH TO POSITION 1 FOR HOT WATER AND 2 FOR HEATING AND HOT WATER, THEN CALL A SERVICE ENGINEER.

1. FAULT FINDING

NO HEATING - HOT WATER OK

1. Check that jumpers on pcb are in correct locations and the pcb has been booted correctly.
2. Check that the heating programmer is set correctly and is calling for heating.
3. Check that the room thermostat setting is adequate and is calling for heating.
4. If both programmer and the room thermostat are calling for heating and the heating is still not working then go to fault finding chart 1.

NO HOT WATER - HEATING OK

1. Check that jumpers on pcb are in correct locations and the pcb has been booted correctly.
2. If a 2 channel clock has been fitted check that the hot water is selected 'ON'.
3. If there is still no hot water then go to fault finding chart 2.

INSUFFICIENT OR INTERMITTENT HOT WATER - SPACE HEATING OK

1. Check that jumpers on pcb are in correct locations and the pcb has been booted correctly.
2. If a 2 channel clock has been fitted check that the hot water is selected 'ON'.
3. If there is still no hot water then go to fault finding chart 3.

NO HEATING AND HOT WATER

1. Check that jumpers on pcb are in correct locations and the pcb has been booted correctly.
2. Check that there is gas supply to the appliance.
3. Check that there is electrical supply to the appliance and the ON/OFF button on the fascia panel is switched on.
4. Check electrical supply is of the correct polarity.
5. If a 2 channel clock has been fitted, check that the heating cannot be selected to 'on' without the hot water being selected to 'on' (programme selector set in the position for 'gravity' operation).
6. If the appliance still does not work then go to fault finding chart 4.

APPLIANCE CONTROL BOARD

The correct operation of the board can be checked by carrying out the following procedure:

- Switch off mains
- Check and if necessary insert correct jumpers (1, 2 & 4 for 12kW 2, 3 & 4 for 18kW models and 1, 2, 3 & 4 for 25kW models) to suit appliance type.
- Insert jumper 5
- Switch on mains
- The PCB will carry out functional checks and then stop.
- Switch off mains
- Remove jumper 5
- Switch on mains to put into normal operating mode.

During the functional checks the green LED's 1-4 will be switched on then off at 5 second intervals

Figure 27 Schematic Wiring Diagram for GulfStream 2000 / 120E and 2000 / 130E (12SP, 18SP, 25SP models)

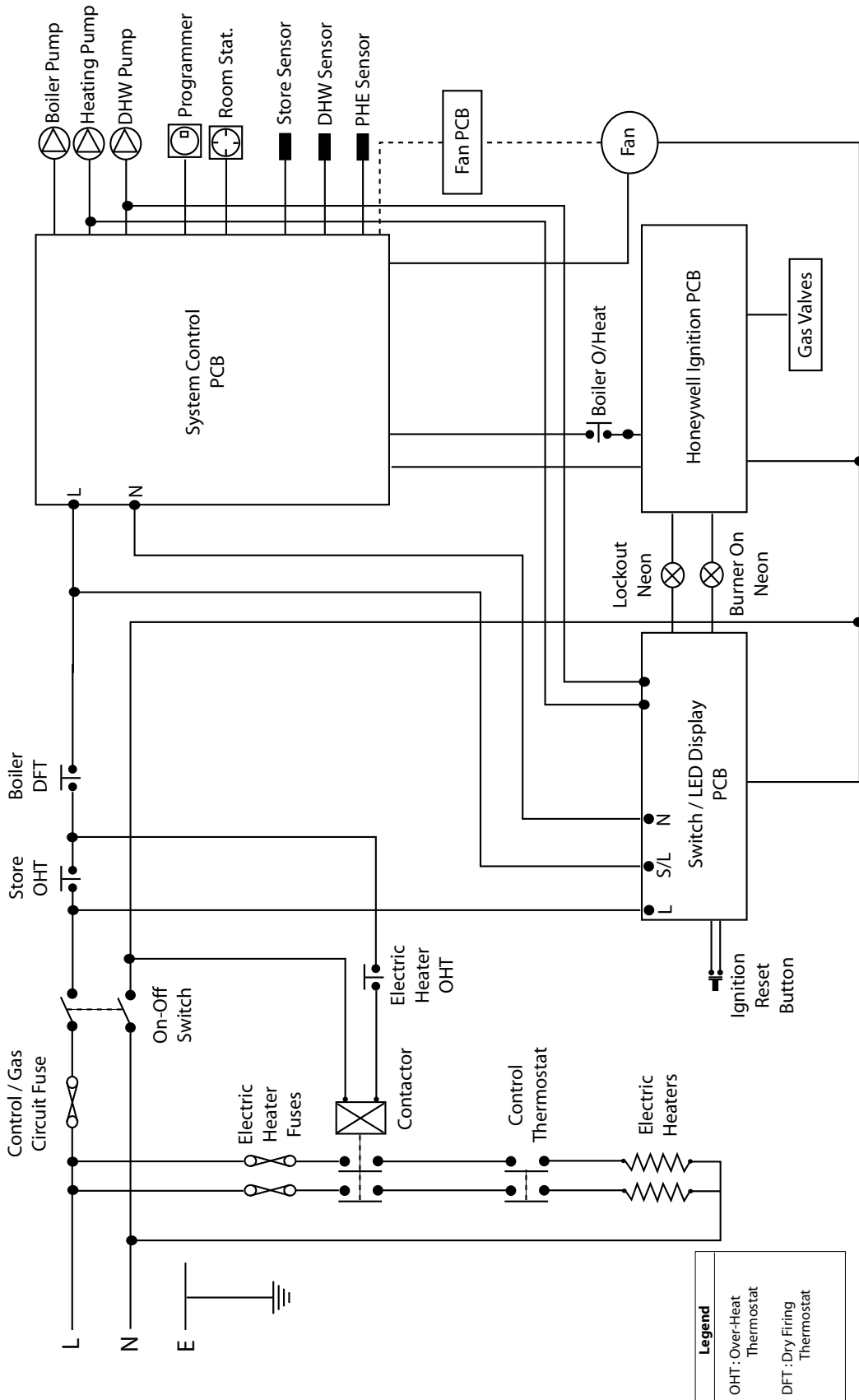
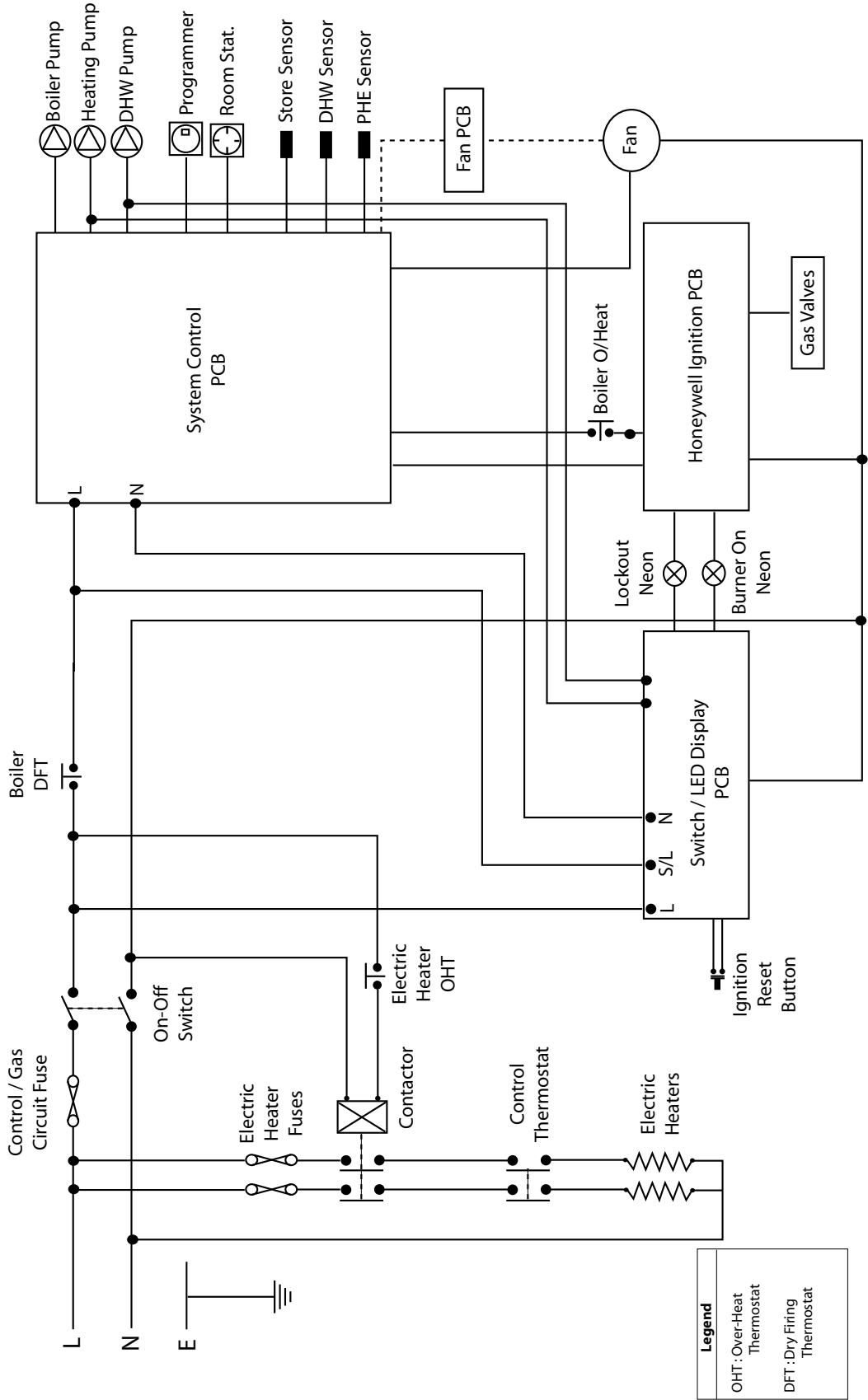
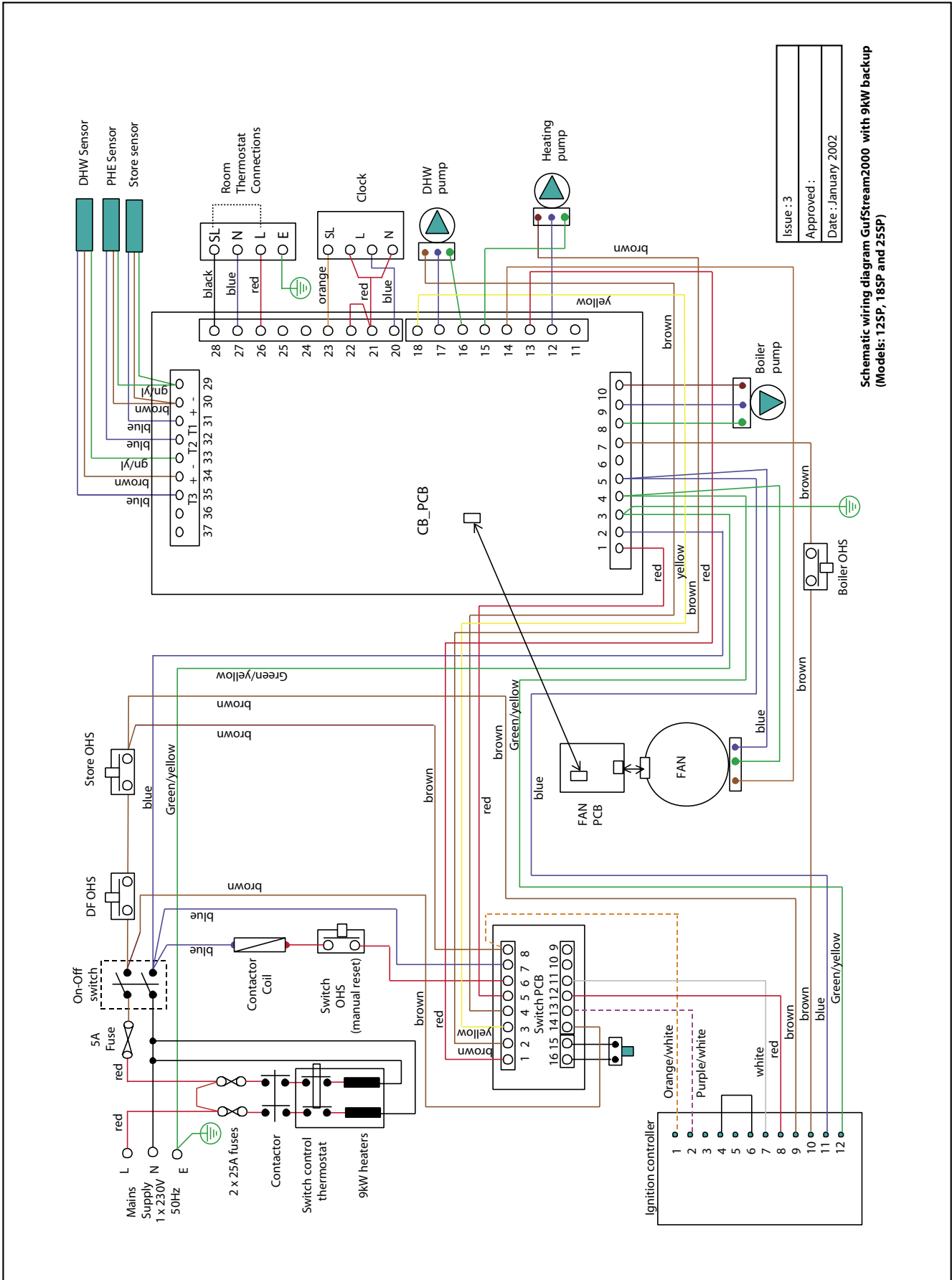

Figure 28 Schematic Wiring Diagram for GulfStream 2000 / 120E - OV and 2000 / 130E - OV (120V, 180V and 250V models)



FAULT FINDING



Issue : 3
 Approved :
 Date : January 2002

Schematic wiring diagram GufStream2000 with 9kW backup (Models: 125P, 185P and 255P)

Figure 29

FAULT FINDING

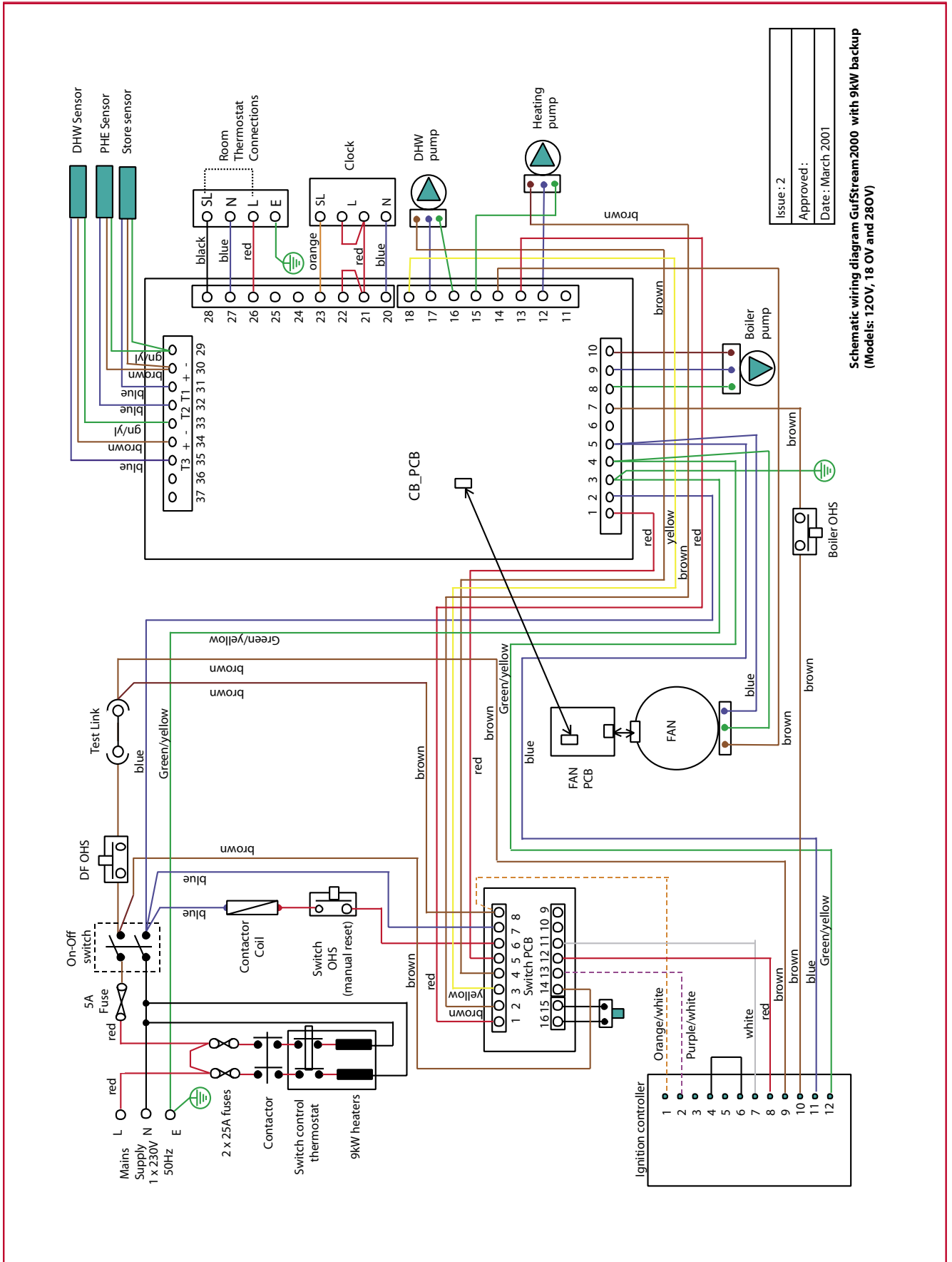
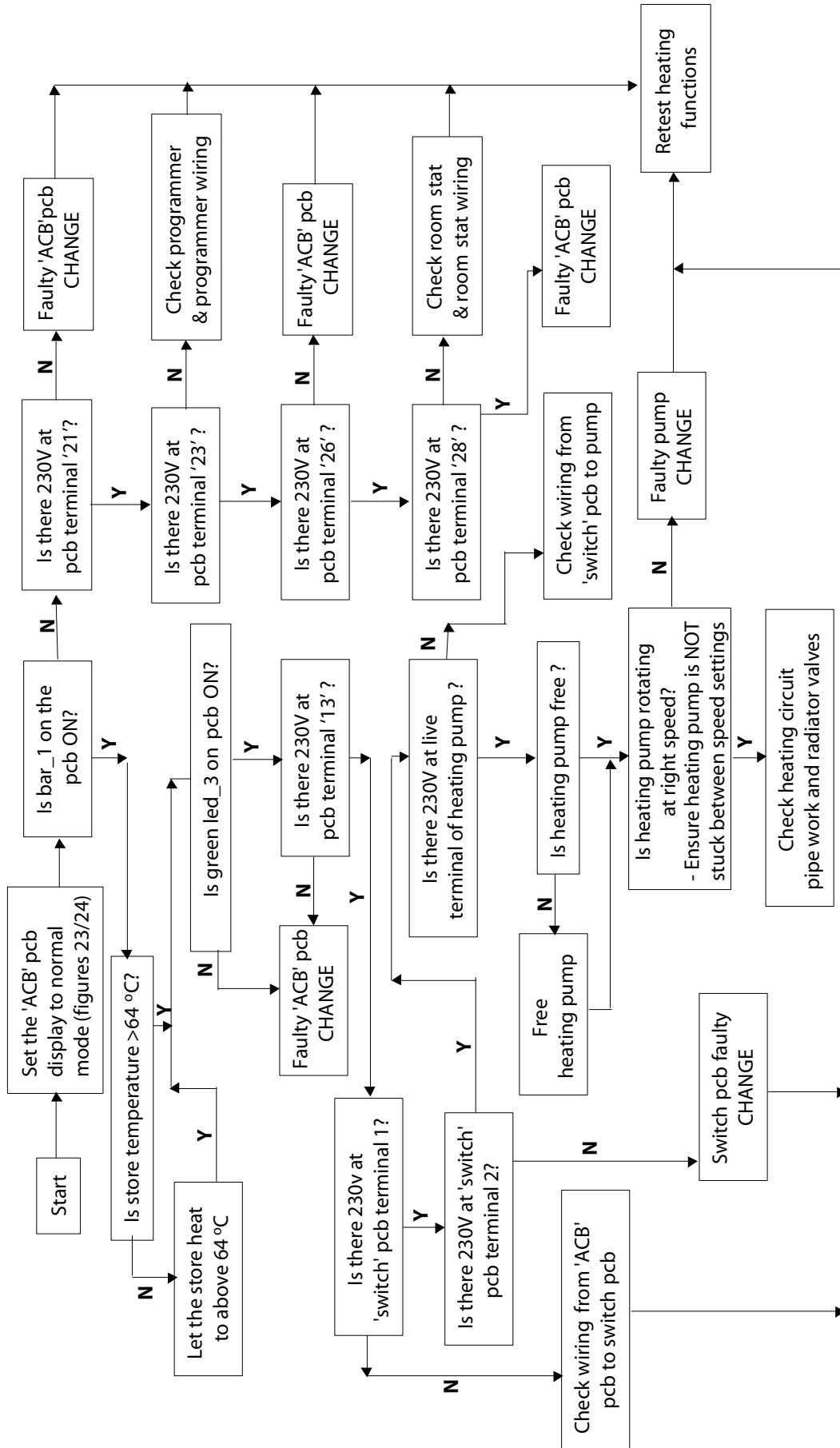
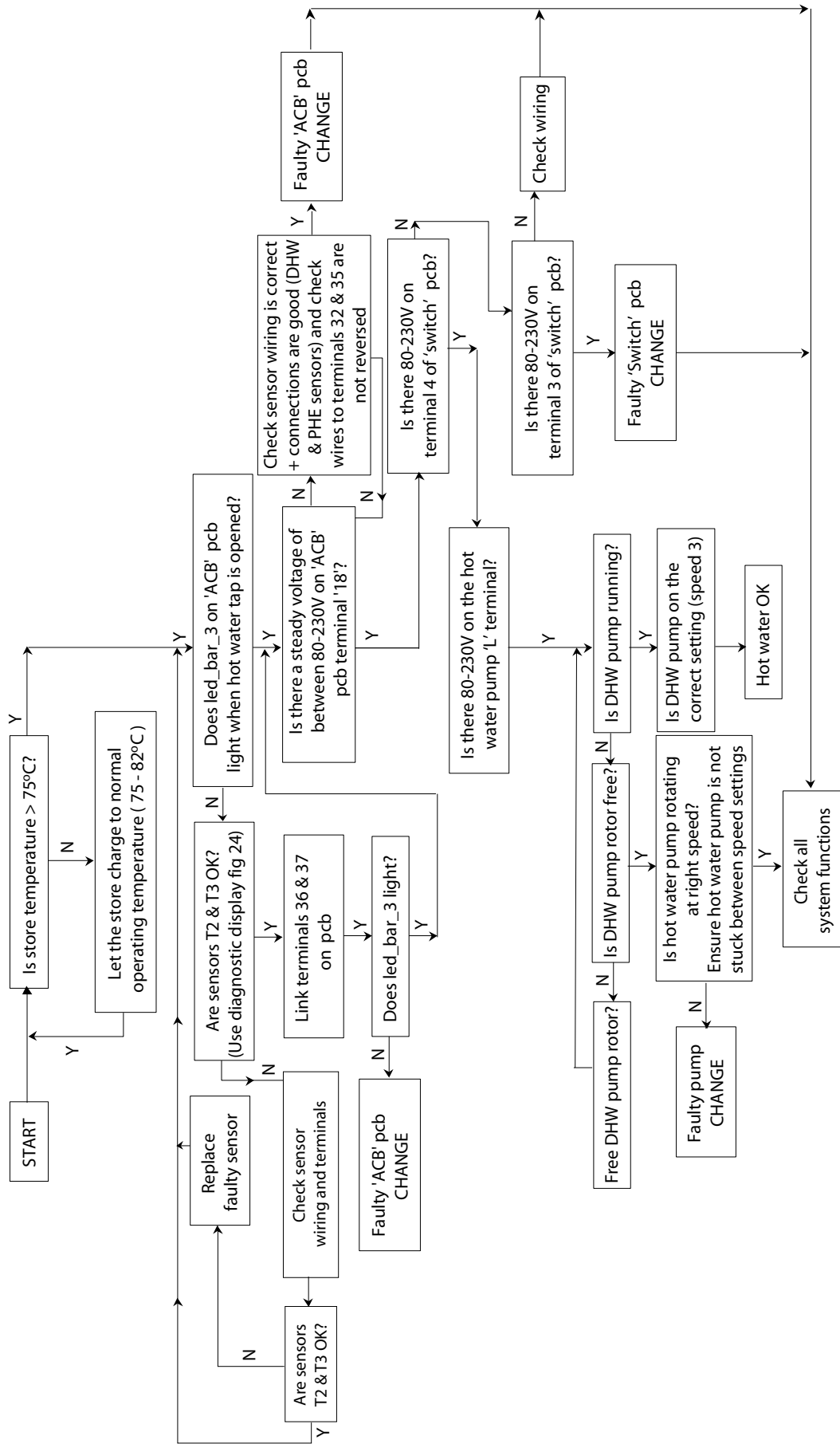

Figure 30

FAULT FINDING CHART 1 : No Space Heating but Hot Water performance is satisfactory
 (Models: 2000/120/E and 2000/130/E)



FAULT FINDING CHART 2 : No Hot Water but Space Heating Performance is satisfactory
(Models: 2000/120/E and 2000/130/E)



FAULT FINDING CHART 3 : Insufficient or Intermittent Hot Water but Space Heating Performance is satisfactory
(Models: 2000/120/E and 2000/130/E)

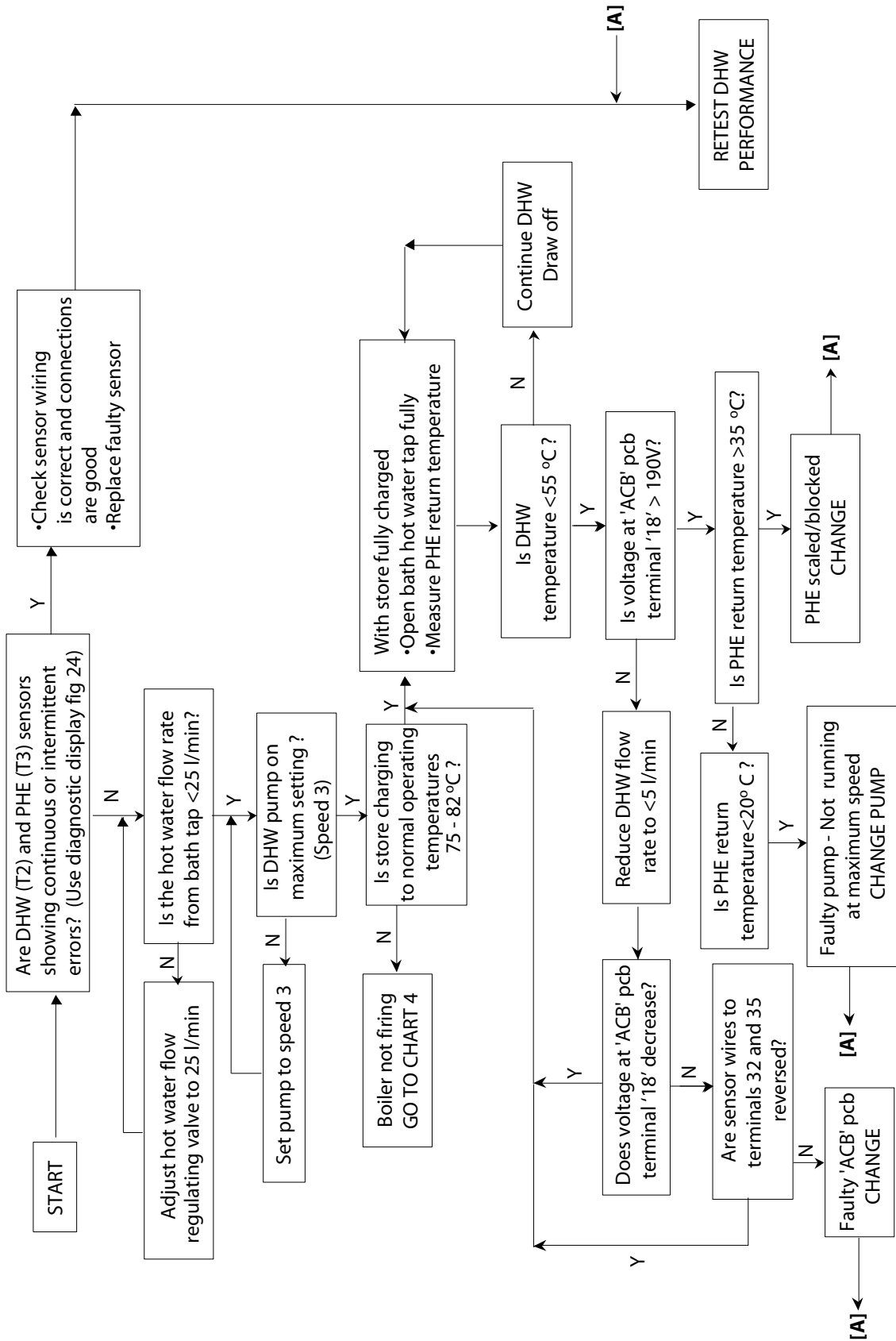

FAULT FINDING CHART 4 : NO Heating and NO Hot water
(Models: 2000/120/E and 2000/130E)

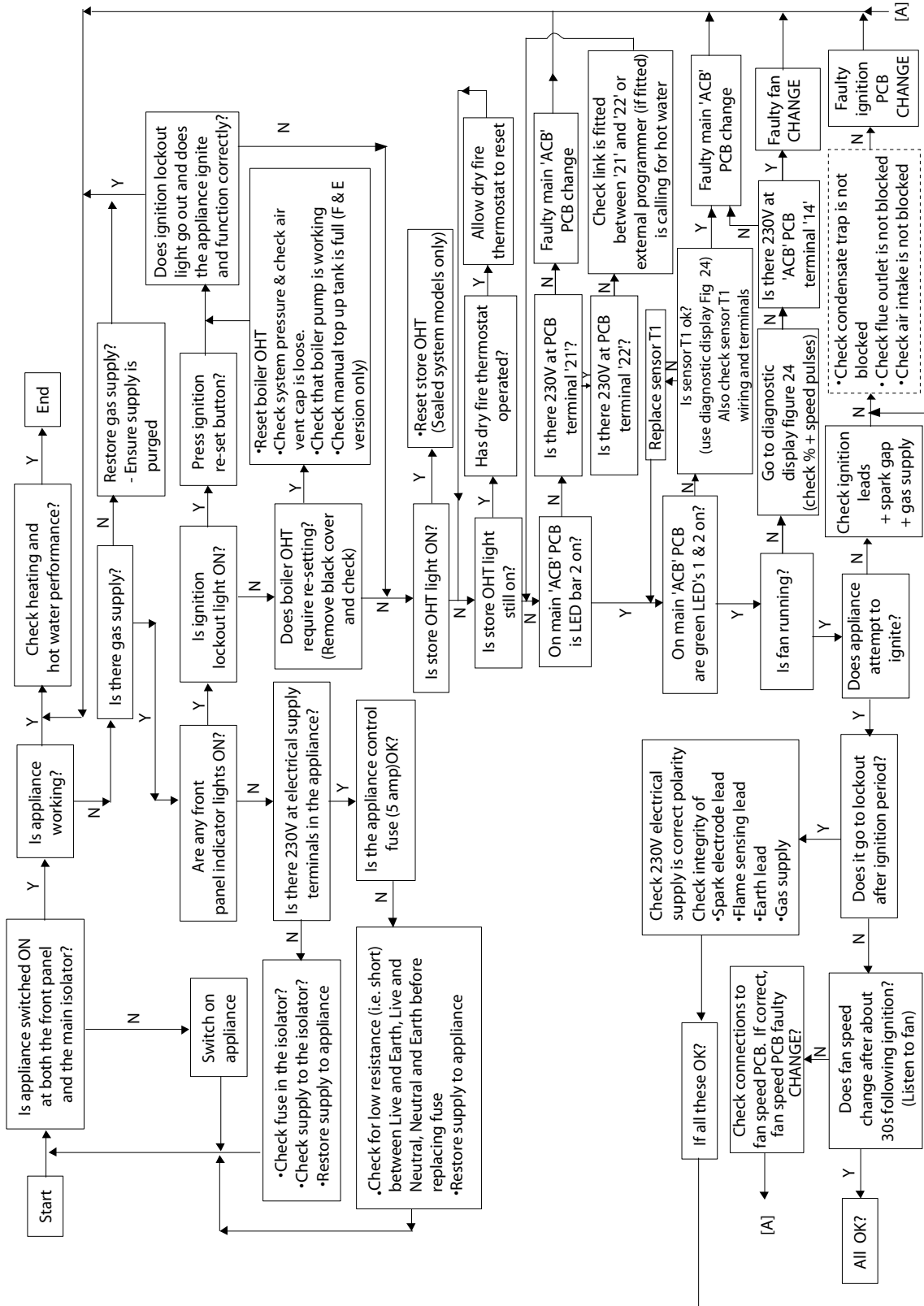

To ensure safe, efficient operation of the appliance, it is necessary to carry out routine servicing at regular intervals. The frequency of servicing will depend on the particular installation conditions and use to which the appliance is put. In general, once a year should be adequate.

It is the law that any service work must be carried out by a competent person such as British Gas or other CORGI registered personnel.

1. ROUTINE ANNUAL SERVICING

IMPORTANT Before commencing a service or changing a component, ISOLATE the mains electric supply TURN OFF the gas supply at the main service cock.

To gain access to all components:

Refer to Figures 1, 2, 4 and 5. First remove the front panel by unscrewing the two retaining screws at the top LH and RH sides. Lift the panel slightly and swing it forward from the top. Lift the panel to disengage it at the bottom edge. Remove the top panel by unscrewing the screws at the LH and RH sides.

A combustion sampling point has been provided on the flue outlet at the base of the boiler. Remove the hex. screw to access (See Figure 4).

2. BURNER, GAS VALVE - VENTURI FAN SUB - ASSEMBLY.

Remove the sub-assembly for inspection Figures 31 and 32. Disconnect HT - Sensor and Earth leads from Honeywell Sequence control box.

Remove the Sequence Control box (fixing screw is under edge connector (RHS) - by pulling to the right. The edge connector need not be removed.

Slacken flexible air hose clip around Venturi inlet and remove hose.

Pull the sensor line off the nipple on the gas valve.

Remove the edge connector at the top rear of the fan housing.

Disconnect the gas line (union connection) from the gas valve.

Remove the (3) hexagon nuts fixing the assembly to the top of the boiler.

Lift the assembly clear of the mounting studs - ease the end of the gas line out of its fitting. When clear lift sufficiently to disconnect the mains supply plug under the bottom rear of the fan housing.

If the assembly is clean (apart from acceptable dust) it will not be necessary normally to disassemble it further, unless careful inspections shows signs of deterioration.

Should it be necessary to remove or replace components, follow the procedures under 'Component Exchange'. Carefully clean the assembly-remove any dust with a soft brush and check for signs of wear or deterioration of supply leads, burner, ignitor and sensor assemblies. The burner must show no sign of oxidation or cracking.

Check and if necessary reset the ignition spark gap to $4.5 \pm 0.5\text{mm}$ and the flame sensor position Figure 32.

3. CLEANING THE HEAT EXCHANGER

Reach down and carefully lift out the central core (ceramic fibre) of the boiler heat exchanger. Examine and replace if there are indications of it beginning to break up or there is evidence of ceramic particles dropping to the bottom of the heat exchanger. Clean the heat exchanger if necessary with a brush and remove any debris.

After completing this part of the service procedure refit the ceramic core to the heat exchanger and reassemble the appliance in reverse order.

CARRY OUT A GAS SOUNDNESS TEST.

Examine the remainder of the appliance checking for signs of deterioration or wear in other components - replace as necessary. Look for signs of water leaks - repair/ replace as necessary.

Refer to the 'Commissioning' Procedure. Operate the appliance - preferably commencing with a dry run (GAS OFF). Check all safety controls and boiler operation under normal conditions. Adjust as necessary,

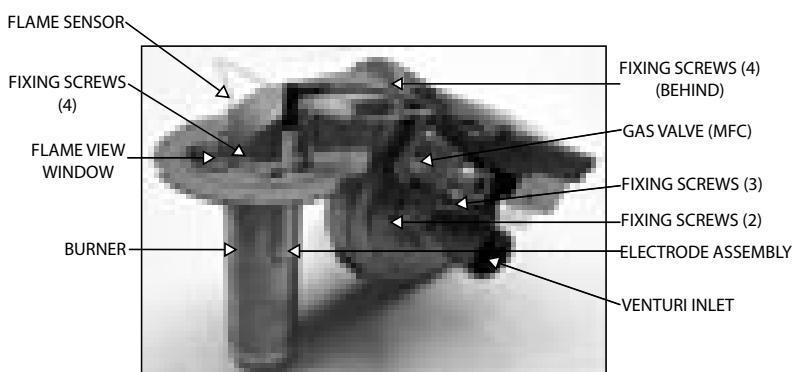

Figure 31

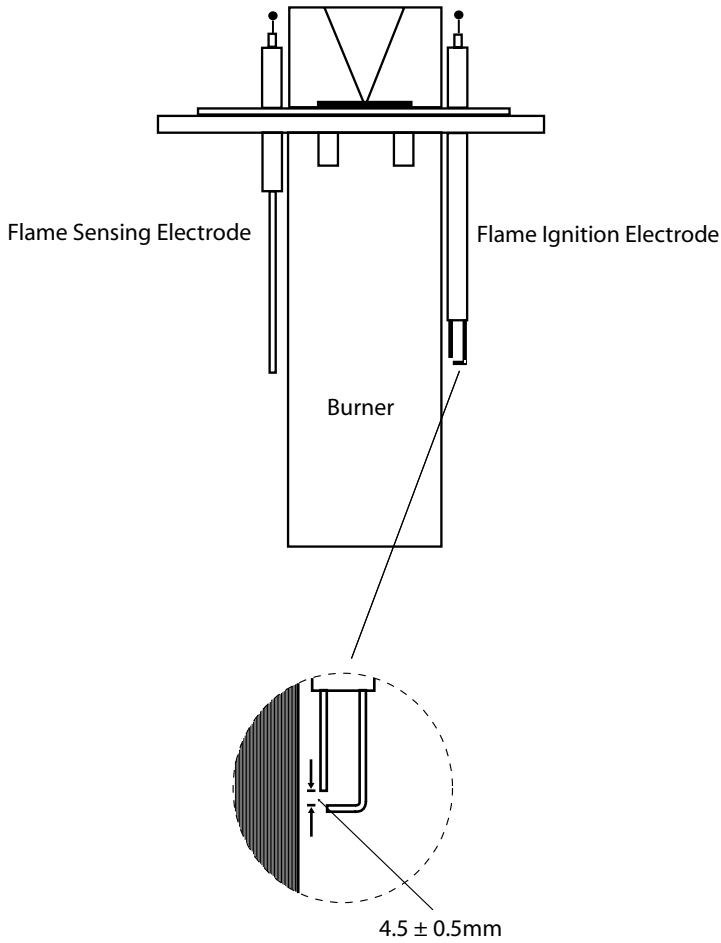

Figure 32

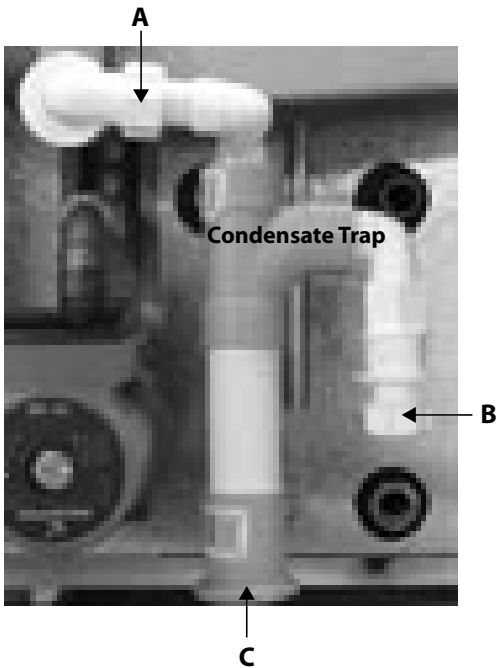

Figure 33

4. CLEANING THE CONDENSATE TRAP

This procedure must be carried out after the appliance has been switched off and made safe. Remove the trap by undoing nuts 'A' and 'B'. Clean the trap by removing plug 'C' taking precautions regarding water in the trap. Refit in reverse order and check for leaks.

POWERFLUSHING/CLEANING OF THE HEATING SYSTEM

If it is proposed to 'powerflush' the heating system we would recommend that the GulfStream appliance is isolated from the heating system being cleaned. Failure to do this could seriously damage the appliance.

When carrying out the work always comply fully with the manufacturers instructions for the powerflushing equipment being used.

If in any doubt please consult our Technical Helpline.

COMPONENT EXCHANGE

IMPORTANT: Before commencing a service or changing a component, ISOLATE the mains electrical supply TURN OFF the gas supply at the service cock.

To assist with a component identification and associated wiring refer to Figures 4, 5, 18, 19, 20, 31 and 32.

GAS VALVE - COMBUSTION FAN - BURNER - VENTURI

The components above form part of a sub-assembly, which must be removed before one of them can be exchanged.

Remove the assembly by following the procedure detailed under 'Routine Annual Servicing.'

GAS VALVE/VENTURI - REMOVAL

Remove these components as a common assembly - then split and replace as necessary. Unscrew the two torq head screws fixing the assembly to the combustion fan housing.

Pull off the assembly. Disconnect the valve from the Venturi by removing the three torq head screws.

DO NOT MISPLACE THE SYNTHETIC RUBBER SEALING WASHER - BETWEEN THE COMPONENTS.

The Venturi is a straight forward replacement. If the gas valve is to be replaced remove the male ½" gas connection from the old valve. Fit it to the replacement valve using an approved jointing compound.

BEFORE re-assembling the gas valve/Venturi check the soundness of the cork gasket and rubber washer. Replace if deterioration or damaged. Check and reset gas rate and burner pressure (page 26 section 7).

NOTE:- Exchange of either gas valve or venturi will necessitate re-commissioning of the appliance.

COMBUSTION AIR FAN - REMOVAL

Remove the main sub-assembly as stated above.

Remove the gas valve/Venturi assembly.

Disconnect the fan from the burner/adaptor casting by removing the (4) hexagon nuts behind the mounting flange.

If necessary exchange the fan and re-assemble in reverse order.

Replace the fan sealing gasket if the existing shows signs of deterioration.

Check boiler/controls operation.

BURNER - REMOVAL

Remove the main sub-assembly stated above.

Disconnect the burner from the burner/adaptor casing by removing the (4) hexagon nuts on top of the casting.

If necessary exchange the burner and reassemble in reverse order.

REPLACE the fan sealing gasket if the existing shows signs of deterioration.

Check boiler/controls operation.

HONEYWELL SEQUENCE CONTROL BOX - REMOVAL

Disconnect HT - Sensor - and Earth leads from control box.

Remove control box - (fixing screw under edge connector - RHS) by pulling to the right. Remove the edge connector. DO NOT pull wires from connector.

If necessary exchange box and reassemble in reverse order.

Check boiler/controls operations.

IGNITION ELECTRODES AND SENSOR REMOVAL

Both components are removed in the same manner.

Disconnect the appropriate leads from the sequence control box i.e.

Ignition Electrodes - HT and EARTH

Sensor - SENSOR LEAD

Remove the (2) cross head screws retaining the component and carefully lift it up out of the combustion chamber.

If necessary exchange the component.

ALWAYS fit a new ceramic sealing gasket.

Re-assemble in reverse order.

Check boiler/controls operation.

FLAME VIEWING WINDOW - REMOVAL

Remove the (2) cross head screws retaining the frame.

Lift off the frame and site glass.

Clean/exchange the site glass as necessary.

ALWAYS fit new ceramic sealing gaskets.

Re-assemble in reverse order.

DRY FIRING THERMOSTAT - REMOVAL

Pull off the leads on top of the thermostat.

Unscrew the body (counter clockwise).

If necessary exchange and re-assemble in reverse order.

Check boiler/controls operation.

STORE OVERHEAT THERMOSTAT - REMOVAL

Remove (pull off) the leads from the back.

Remove the central fixing nut.

Remove the split pin at the thermostat phial pocket and pull out the phial.

Remove the thermostat by passing the capillary tube and phial through the adjacent hole in the bulkhead.

Replace as necessary and re-assemble in reverse order. Finally depress thermostat reset button.

Check boiler/controls operation.

COMPONENT EXCHANGE

BOILER OVERHEAT THERMOSTAT - REMOVAL

Remove screw on cover (counter clockwise) at the front of the thermostat. Remove the central fixing nut. Remove (pull off) the leads from the back.
Remove the split pin at the thermostat phial pocket and pull out the phial.
Remove the thermostat, capillary and phial through the top of the casing.
Exchange if necessary and re-assemble in reverse order.
Finally depress thermostat reset button before fitting cover.
Check boiler/controls operation.

PRESSURE GAUGE REMOVAL

Isolate the appliance from the heating system. Turn off supply to auto-make up tank if fitted. Open the safety valve to release internal boiler pressure. Drain down the boiler to below the level of the safety valve. Unscrew (counter clockwise) the capillary at the valve. Remove the knurled nut at the back of the gauge and pull the capillary out through the panel.
If necessary exchange and re-assemble in reverse order.
Refill the boiler ensuring all air is removed.
UNDERTAKE WATER SOUNDNESS TEST.
Check boiler/controls operation.

SAFETY (PRESSURE RELEASE) VALVE

Isolate the appliance from the heating system. Turn off the supply to any auto make up tank if fitted. Open the safety valve to release any internal pressure. Drain down the boiler to below the level of the safety valve.
Operate the valve once more to remove residual water and disconnect the capillary of the pressure gauge from the valve.
Disconnect the valve discharge pipe and unscrew (counter clockwise) the valve from its mounting. If necessary exchange the valve and re-assemble in reverse order.
Refill the boiler ensuring all air is removed.
when full operate the valve and ensure that at normal operating pressure (1.0 - 1.2) bar cold, the valve is water tight.
Check boiler/controls operation.

EXPANSION VESSEL - REMOVAL

Isolate the appliance from the heating system.
Turn off the supply to any auto-make up tank if fitted. Open the safety valve to release any internal pressure. Drain down the boiler to below the level of the safety valve. Remove all residual water possible through safety valve discharge.
Disconnect the flexible pipe from the front of the expansion vessel and pull the vessel forward out of its recess. DO NOT MISPLACE THE SEALING WASHER.
Exchange the vessel if required and re-assemble in reverse order.
Refill the boiler ensuring all air is removed.
UNDERTAKE WATER SOUNDNESS TEST.
Check boiler/controls operation.

FASCIA MOUNTED SELECTOR SWITCH PCB - REMOVAL - SWITCH FACILITY

Remove terminal/block plugs (3) at rear of pcb.
Remove control knob - (allen key headed grub screw at back of knob).
Remove single nut fixing behind control knob and remove PCB complete with reset button.
Replace if necessary and re-assemble in reverse order. Replace any severed cable ties.
Check boiler/controls operation.

RESET BUTTON

Disconnect single nut fixing from reset button and push it through hole in panel. Replace if necessary and re-assemble in reverse order.
Check boiler/controls operation.

TIMER - REMOVAL

Pull off transparent protective cover.
Remove push on connectors at rear of timer body.
Release screw catches at front (top LH and bottom RH).
Pull timer forward to release from panel.
Replace if necessary and re-assemble in reverse order.
Check boiler/controls operation.

FAN CONTROL PCB - REMOVAL

Remove the two ribbon connector plugs from the PCB.
Lift the PCB off its supports (4).
Replace if necessary and re-assemble in reverse order.
Check boiler/controls operation.

MAIN 'ACB' PCB - REMOVAL

Pull off the terminal/block plugs (4) at the edge of the PCB.
Remove the ribbon connector plug in the centre.
Lift the PCB off its supports (8).
Replace if necessary and re-assemble in reverse order. Ensure jumper positions are correct. (see figure 23).
Check boiler/controls operation.

PHE SENSOR (PLATE RETURN) - REMOVAL

Isolate the boiler from the heating system.
Turn off the supply to any auto-make up tank, if fitted. Open the safety valve to release any internal pressure. Drain down the boiler.
Identify the appropriate cable connections at the main PCB. Disconnect the sensor cables. Cut any cable ties necessary to strip out the cable back to the sensor head.
NOTE: If the PHE sensor is to be replaced remove the electric boiler cover (if fitted).
Remove fixing screws (2) at top and under side of cover.
Unscrew sensor (counter clockwise) - replace if necessary. Re-assemble in reverse order.
Replace cable ties.
UNDERTAKE WATER SOUNDNESS TEST.
Check boiler/controls operation.

COMPONENT EXCHANGE

DHW SENSOR - REMOVAL

Identify the appropriate cable connections at the main PCB. Disconnect the sensor cables. Cut any cable ties necessary to strip out the cable back to the sensor head.

Unscrew sensor (counter clockwise) - replace if necessary. Re-assemble in reverse order.

Replace cable ties.

UNDERTAKE WATER SOUNDNESS TEST.

Check boiler/controls operation.

STORE SENSOR - REMOVAL

Identify the appropriate cable connections at the main PCB. Disconnect the sensor cables. Cut any cable ties necessary to strip out the cable back to the sensor head.

Remove the R cup at the sensor pocket and pull out the sensor.

Replace if necessary and re-assemble in reverse order.

Replace cable ties.

Check boiler/controls operation.

PLATE HEAT EXCHANGER - REMOVAL

Isolate the boiler from the heating system.

Turn off the supply to any auto makeup tank if fitted. Open the safety valve to release any internal pressure. Drain down the boiler.

Disconnect the union connectors (4) at the corners of the plate heat exchanger and remove it.

When draining the plate heat exchanger take precautions against standby water in the pipework and the heat exchanger.

Replace if necessary and re-assemble in reverse order.

NOTE:- Check the condition of the sealing washers at each connection and replace if damaged.

UNDERTAKE WATER SOUNDNESS TEST.

Check boiler/controls operation.

ELECTRIC BOILER - REMOVAL

Isolate the boiler from the heating system.

Turn off the supply to any auto makeup tank if fitted. Open the safety valve to release any pressure. Drain down the boiler.

Remove safety cover as described below.

Disconnect mains supply cables to the heater element and the control thermostat.

Disconnect the union connectors (2) at top and bottom of electric boiler and remove it.

When removing the electric boiler take precautions against any standing water in the pipework.

Replace if necessary and re-assemble in reverse order.

NOTE:- Check the condition of the sealing washers at both connections and replace if damaged.

UNDERTAKE WATER SOUNDNESS TEST.

Replace any cable ties.

Check boiler/controls operation.

REMOVING ELECTRIC BOILER SAFETY COVER

Remove safety cover by undoing two screws at top and bottom.

Disconnect electric boiler overhear thermostat wires.

Remove the electric boiler overhear thermostat phial from the pocket by first removing the securing pin.

The safety cover can now be moved away from the appliance.

ELECTRIC BOILER OVERHEAT THERMOSTAT - REMOVAL

Remove electric boiler safety cover as described above.

Disconnect the cables from the control thermostat.

Re-assemble in reverse order.

ELECTRIC BOILER OVERHEAT THERMOSTAT - REMOVAL

Remove electric boiler safety cover as described above.

Remove thermostat from the safety cover and replace if necessary.

Re-assemble in reverse order.

DHW AND CH PUMP - REMOVAL

Close the isolation valves on the pump to be removed.

Remove the protective cover from the pump terminal block and disconnect the supply cable.

Loosen the isolation valve unions and remove the pump - alternatively just change pump head using allen key.

NOTE:- SOME RESIDUAL WATER FROM THE PUMP HOUSING IS UNAVOIDABLE.

Replace if necessary and re-assemble in reverse order.

NOTE:- Check the condition of the sealing washers at both isolation valves and replace if damaged.

UNDERTAKE WATER SOUNDESS TEST.

Check boiler/controls operation.

BOILER (HEAT EXCHANGER) PUMP - REMOVAL

Isolate the boiler from the heating system. Turn off the supply to any auto makeup tank if fitted. Open the safety valve to release any residual pressure. Drain down the boiler. Remove the protective cover from the pump terminal block and disconnect the supply cable. Remove the pump motor from the impellor housing - four allen key head screws.

Check the housing is clean and free from debris.

Replace with a new motor if necessary and re-assemble in reverse order.

NOTE:- Replace any damaged pump seals.

UNDERTAKE WATER SOUNDNESS TEST.

Check boiler controls and operation.

SPARE PARTS LIST

Description	No. Off	Stock Code No.	Gas Council Part No.
Ball Valve	1	FT206	370 505
Red plastic float	1	FT429	370 506
Top up tank	1	XB343	
½" Drain cock	1	GS028	
SAC store temperature sensor 2.5m	1	GT147	
Fan modulation PCB	1	GT148	
Pump speed temperature sensor	2	GT153	E05-667
Appliance Control Board (ACB)	1	GT155	
PCB supports	10	XB045	
AC 30 fuse base	2	XB363	E39-160
3025 LC fuse	2	XB364	E39-161
½" Automatic air vent	1	GT015	E02-750
Plate heat exchanger	1	GT017	E05-664
½" Gas tap LH	1	GT025	
Non return valve	1	GT048	E37-479
Brass housing for non return valve	1	GT049	
Boiler overheat thermostat 100°C manual set	1	GT188	
Boiler dry firing safety thermostat manual set	1	GT186	
Exhaust gas seal	1	GT191	
½" Flange 'O' ring and screws	1	GT192	
Feedback nipple	2	GT193	
3 Bar expansion relief valve	1	GT195	
Grundfos 15/50 pump	2	XB001	384-228
Grundfos 15/50 pump 90° casting 1" connections	1	GT176	
22mm Balltype valve	4	XB002	370-508
Grasslin mechanical clock	1	XB215	385-873
Grasslin digital clock	1	XB216	385-874
Single check valve	1	XB262	
22mm isolation valve	1	XB334	
Switch immersion element	1	XB342	
Switch control thermostat	1	XB344	
Switch overheat thermostat	1	XB345	
3/8" clevis retaining clip	2	XB351	
Quarter turn clip	2	XB357	
Quarter turn washer	2	XB358	
Quarter turn spring	2	XB359	
Quarter turn stud	2	XB360	

SPARE PARTS LIST

15mm filling loop	1	XG118	E27-790
Flexible air inlet duct	1	XS034	
Burner - clips for flexible air inlet duct	1	XS035	
Screw M4 x 10mm	6	XS036	
Nut M5 self locking	4	XS037	
Set screw M4 x 25mm	4	XS038	
Sight glass	1	XS039	
Gasket sight glass	1	XS040	
Holder sight glass	1	XS041	
Tab 6.3 x 0.8mm	1	XS042	
Spark electrode	1	XS043	
Flame sensing electrode	1	XS044	
Gasket electrode	2	XS045	
Gasket burner	1	XS046	
Heat exchanger profile	1	XS047	
Combi flange	2	XS048	
O ring 126 x 6mm	2	XS049	
Stud bolt M5 x 12mm	11	XS050	
Store overheat thermostat 98°C manual set	1	GT064	397-978
12 lt expansion vessel	1	GT162	
Pressure gauge	1	GT161	
Burner assembly without fan	1	GT163	
Gasket for fan	1	GT165	
Displacement ceramic core	1	GT166	
Displacement tube above	1	GT167	
Displacement tube below	1	GT168	
Locking strip	1	GT169	
Flue gas outlet duct	1	GT170	
Ignition lead	1	GT172	
High pressure fan	1	GT174	
Dedicated ignition control	1	GT175	
Gas valve	1	GT185	
Air/gas Venturi			
Venturi gasket			
80mm flue pipe seal			
60mm flue pipe seal			
Fan PCB Fan lead with plugs			
Fan PCB Main PCB lead with plugs			
'Y' Type Strainer	1	XB314	
Flow regulator	1	GT086	

APPENDIX A

GULFSTREAM 2000 - SP MODELS ONLY

Design/Installation details for the CA type backflow prevention valve assembly and anti-vacuum valve

CA VALVE ASSEMBLY

The above components are supplied loose with the SP models only and will need to be installed on site adjacent to the appliance in accordance with the following instructions ;

The CA type backflow prevention valve and pressure regulating valve assembly provides automatic filling of the appliance/sealed heating system from a permanent connection to the mains cold water supply.

This is now allowed by the Water Regulations to stop any possible contamination of the mains cold water supply by the water in the heating system.

This replaces the temporary filling loop arrangement historically required by the Water Byelaws and means the connection to the mains cold water supply can be permanent. This will allow any loss of water from the heating system to be automatically replenished as with an open vented system fitted with a feed and expansion cistern.

Details of the valve assembly and its installation requirements are shown opposite.

The valve requires a pressure differential to operate correctly and a minimum dynamic pressure of 2.0 bar is required at the connection to the appliance under maximum domestic water simultaneous demand conditions.

The pressure regulating valve is set to 1.0 bar. This is usually sufficient for the heating systems in most domestic properties and is the same as the factory setting for the expansion vessel supplied with the appliance.

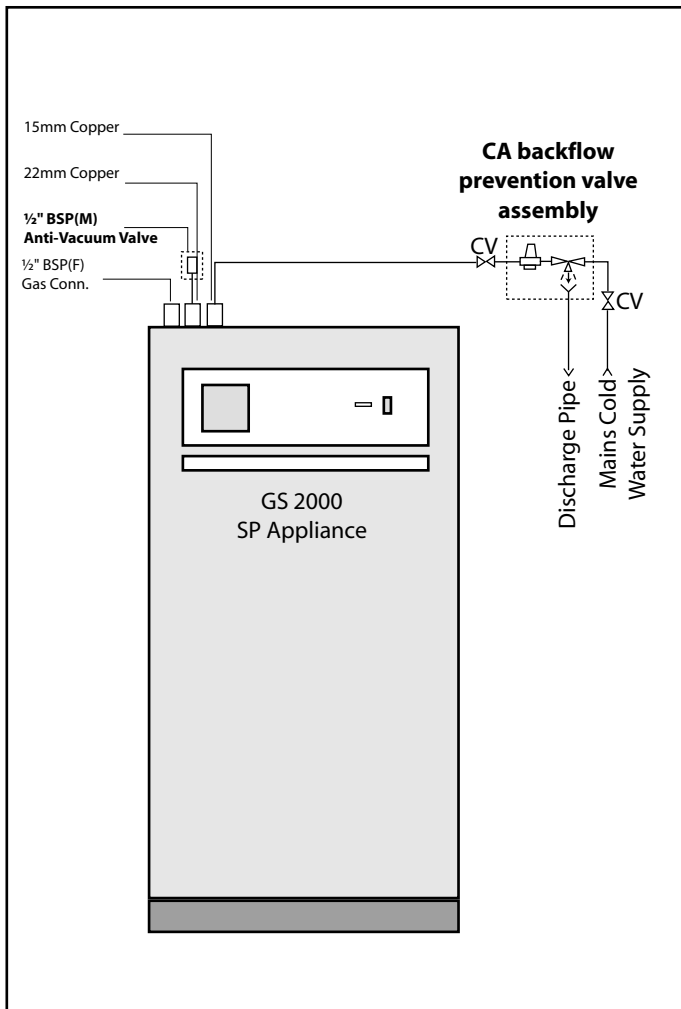
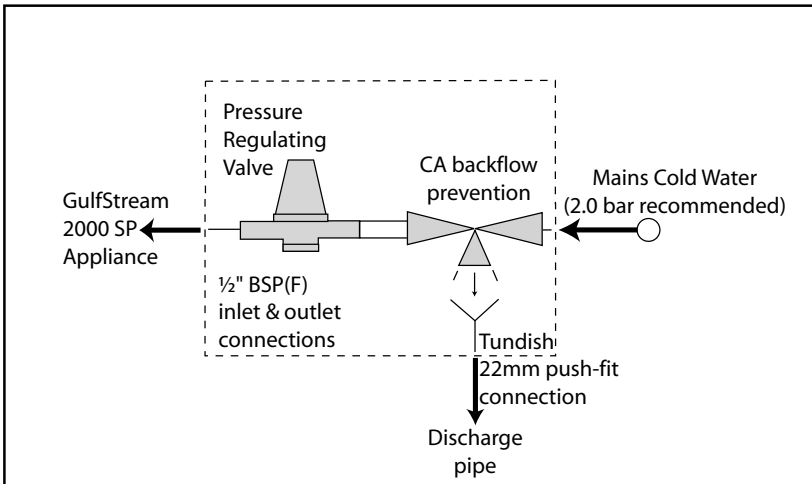

APPENDIX A

GULFSTREAM 2000 - SP MODELS ONLY

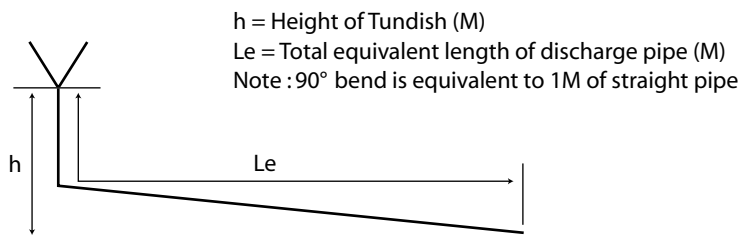

The CA backflow prevention valve assembly is supplied complete with a tundish for connection to the discharge pipe.

The construction of the valve is such that the mains cold water cannot discharge through the tundish even when the mains side check valve is faulty. This is because the sliding piston, which opens the main port also closes the vent (i.e. tundish) port. The valve will therefore only discharge if the check valve on the appliance/system side is faulty and the mains pressure is less than the pressure in the appliance/system.

The discharge pipe must have a continuous fall throughout its length. The method of sizing the pipe is shown opposite. A 22mm minimum diameter discharge pipe is recommended, (the discharge pipe diameter **must** be at least one size larger than the cold water inlet).

DISCHARGE PIPE DIAMETERS

Height - h (M)	Pipe Size	Maximum Le (M)
0.2	15mm	1
	22mm	9
	28mm	30
0.3	15mm	2
	22mm	13
	28mm	45
0.4	15mm	3
	22mm	19
	28mm	63
0.6	15mm	4
	22mm	27
	28mm	94
0.8	22mm	5
	22mm	37
	28mm	127
1	15mm	7
	22mm	46
	28mm	157

NOTE : DO NOT open the control/isolating valves (C.V.) for the CA backflow prevention valve until the heating system is complete.

ANTI-VACUUM VALVE

Details of where to fit the anti-vacuum valve are shown in the diagram of the appliance on page 1.

WARRANTY

Please note that the CA valve and anti-vacuum valve **MUST** be fitted with the SP model to enjoy the full benefits of the Warranty.

APPENDIX B

WATER SAVINGS

WATER RELATED COSTS CAN BE REDUCED BY GOOD PLUMBING PRACTICE.

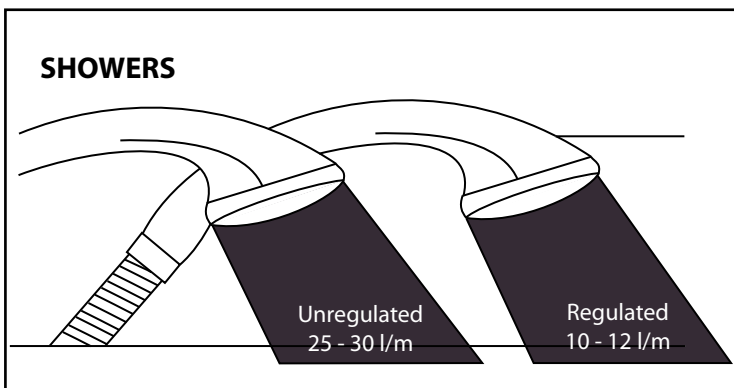
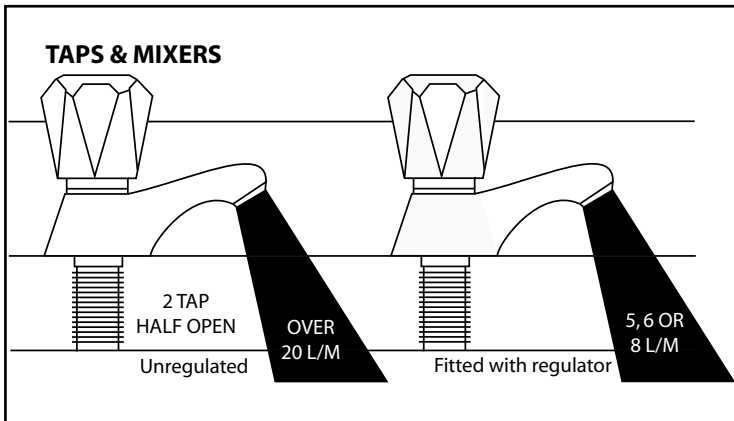

Vast quantities of water are needlessly run off to waste due to Taps, Mixers and Showers discharging flow rates far in excess of the rates required for them to perform their duties.

The contrasting flow rates shown on this leaflet clearly illustrate the savings that can be made whilst still providing a good performance.

British made Aquaflow Regulators provide constant flow rates by automatically compensating for supply pressure changes between 1 bar & 10 bars.

To facilitate installation into the wide range of plumbing equipment which is encountered in the U.K, Four Fixing Options are available:-

OPTIONS FOR SHOWERS

1. MXF "DW" Range - For fitting behind Fixed Shower Heads or onto Flexible Hoses for Handshowers (preferably onto the inlet end when lightweight hoses are used).
2. Compression Fitting Range. "In Line" regulators as in Option 4 for Taps & Mixers.

INFORMATION BY COURTESY OF
AQUAFLOW REGULATORS LTD

HAYWOOD HOUSE, 40 NEW ROAD, STOURBRIDGE, WEST MIDLANDS DY8 1PA
TELEPHONE (01384) 442611 FAX: (01384) 442612

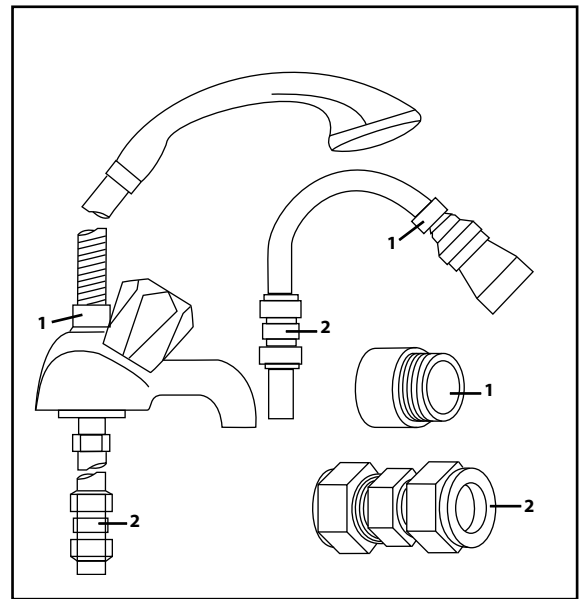

4 FIXING OPTIONS FOR TAPS & MIXERS

1. MK Range - Combined Regulators & Aerator for screwing onto Taps & Mixers with internal or external threads on their noses. Anti Vandal models also available.
2. MR05-T Range - Internal Regulators. Push-fit into Tap or Mixer seats. Produced in three sizes - 12.5mm (BS1010), 12mm & 10mm, Flangeless models also available for Taps with Low Lift washers.
3. MXF Standard Range - Screw on tail models for Taps & Mixers. Fix onto the tails before fitting the tap connectors. Available in 3/8", 1/2", 3/4" and 1" BSP.
4. Compression Fitting Range - "In Line" regulators housed in 15mm & 22mm CXC Couplers & Isolating Valves. ^{UNIVERSITY} ~~UNIVERSITY~~ by the Water Research Centre. Isolation valves available for slotted screwdriver operation or with coloured plastic handles. Now available also in plastic bodied push-fit couplers & valves.

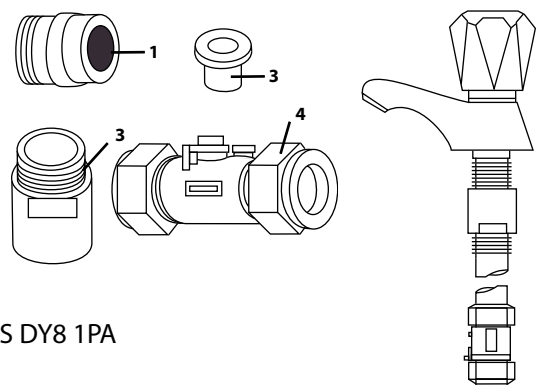

1. We only do business upon the Conditions which appear below and no other. Unless we so agree in writing these Conditions shall apply in full to any supply of goods by us to the exclusion of any Conditions or terms sought to be imposed by any purchaser. These Conditions of Sale and Warranty Terms override those which are contained on the Invoice Forms and all Sales are now subject to these Conditions of Sale and Warranty terms only.

2. PRICE

Orders are accepted at the price ruling at the date of receipt of order, this price is our last published list price plus a supplement to allow for any increase in the price of copper between the dates of publication of our price lists ("the copper price supplement"). An order may not be cancelled or varied after acceptance without the written consent of the company. Such cancellation or variation shall be subject to such reasonable charges as may be appropriate.

3. SPECIFICATION

The goods are supplied in accordance with the Specifications (if any) submitted to the Purchaser and any additions and alterations shall be the subject of an extra charge. Any goods not so specified shall be in accordance with our printed literature or the literature of any of our component suppliers (subject to any modifications made since publication). If we adopt any changes in construction or design of the goods, or in the specification printed in our literature, the Purchaser shall accept the goods so changed in fulfilment of the order.

4. PAYMENT

The invoice price of goods shall be payable within 30 days of despatch by us of our invoice for the goods or such longer time as may be stated by our quotation or invoice. If we receive payment in full on or before the due date we will allow a discount of 5% except where we have quoted a special net price. If payment is not received in full on or before the due date we shall be entitled in addition to the invoice price to:

- (i) payment of a sum equal to any increase in the copper price supplement applicable to the particular goods sold between the date of receipt of order and the date of receipt of payment in full; and
- (ii) interest on any part of the invoice price unpaid after the due date at the rate of 3% per annum over the base rate for the time being of Midland Bank plc.

5. TIME

We give estimates of delivery dates in good faith and time of delivery is not nor shall be made of the essence of any contract nor shall we be liable for any loss or damage occasioned by delay in delivery.

6. DELIVERY

We deliver free normally by our own vehicles within 25 miles of any of our manufacturing depots. Delivery to any place more than 25 miles from one of our manufacturing depots is subject to our quoted delivery charges. We reserve the right to make delivery of goods contained in one order by more than one consignment and at different times. Where a period is agreed for delivery and such period is not extended by our Agreement, the Purchaser shall take delivery within that period. If the Purchaser fails to take delivery, we shall be entitled at the Purchaser's risk and expense to store the goods at the Purchaser's premises or elsewhere and to demand payment as if they had been despatched. Offloading at point of delivery shall be the responsibility of and be undertaken by the Purchaser.

7. SHORTAGES OR DAMAGE

Goods must be inspected before signature of delivery note and any damage, shortage or discrepancy noted on the delivery note and the goods returned on the same vehicle. The buyer must also give us immediate written notice of the damage, shortage or discrepancy so that we may prompt investigation.

8. RETURN OF GOODS

Goods may not be returned to the Company except by prior written permission of an authorised officer of the Company and such return shall be subject to payment by the Purchaser of handling and re-stocking charges, transport and all other costs incurred by the Company.

9. COMPANY LIABILITY

All our goods are made of the best materials from reputable manufacturers and where stated are manufactured to the appropriate British Standard. Complaints must be given to us immediately, before any action is taken, as responsibility cannot be accepted if repairs or renewals are attempted on site without our written authority.

Where we agree to rectify any defect, we reserve the right to undertake the work on our own premises. Provided that our product has been installed in accordance with any instructions for installation any any relevant codes of practice and in accordance with the bye-laws and requirements obtaining in any particular area we give the following warranties:

(1) Domestic and Commercial Open Vented Cylinders and Tanks.

If the copper cylinder or tank or any integral pipework proves to be defective either in materials or workmanship, we will either repair or supply replacement at our option with the closest substitute in the case of any obsolete product to any address in Great Britain.

- (a) free of all charge during the first year after delivery by us.
- (b) thereafter at a charge of one-tenth of the then current list price and any copper price supplement and delivery charge during the second year after delivery by us and increasing by a further one-tenth on the second and subsequent anniversary of delivery by us.

AND FURTHER we will meet the contractors/installers reasonable costs in removing and replacing any defective Open Vented Copper Cylinder or Tank with defective integral pipework as follows:

- (i) in the case of vessels of less than 80 imperial gallons capacity up to a maximum of one-half of the extent of our liability in regard to the replacement product expressed in (1) (a) and (b) above
- ii) in the case of vessels larger than 79 imperial gallons capacity up to a maximum of one-quarter of the extent of our liability in regard to the replacement product as expressed in paragraphs (1) (a) and (b) above.

(2) Domestic Mains Fed Products

If the copper storage vessel itself or any integral pipework as part of the storage vessel assembly proves to be defective either in materials or workmanship, we reserve the right to either repair or supply replacements or the closest possible substitute in the case of any obsolete product and will collect and deliver to any address in England, Wales and Scotland (excluding all Scottish Islands).

(a) free of all charge during the first year after delivery by us.

(b) thereafter at a charge of one-fifth of the then current list price or any copper price supplement and delivery charge during the second year after delivery by us increasing by a further one-fifth on the second and subsequent anniversary of delivery by us.

AND FURTHER we will meet the contractors/installers reasonable costs in removing and replacing any defective copper storage vessel or storage vessel with defective integral pipework from the Domestic Mains Pressure Range of products up to a maximum of one-third of the extent of our liability in regard to the replacement product expressed in (2) (a) and (b) above.

(3) Components of our products other than Storage Vessels and Integral Pipework. We will either extend to the purchaser the same terms of warranty as we are given by the manufacturer of the component or if the manufacturer does not give any warranty, replace free of charge any component which becomes defective within twelve months after the date of the delivery by us and is returned to us at the purchaser's expense but we shall not meet the cost of removal or shipping or return of the component or any other cost charges or damages incurred by the purchaser.

(4) In the case of the GulfStream range of products any heat generator found to be defective and admitted to be such by us either as regards materials or workmanship within 12 months from date of installation or 18 months from date of manufacture whichever is the sooner, will be repaired or replaced at our option. **AND FURTHER** we will meet the contractors/installers reasonable costs in removing and replacing any defective heat generator up to a maximum of one-third of the extent of our liability in regard to the replacement product.

(5) In the case of goods manufactured solely in accordance with our specification and designs and in respect of any installation work carried out by or on our behalf, our entire liability and the purchaser's sole remedies (subject to (1-4) above) and shall be as follows:

(a) we accept liability for death or personal injury to the extent that it results from our negligence that of our employees agents or subcontractors.

(b) subject to paragraph (d) below, we accept liability for direct physical damage to tangible property to the extent that such damage is caused by our negligence that of our employees agents or subcontractors.

(c) our total liability to the purchaser over and above any liability to replace under (1 - 4) above (whether in contract or in tort including negligence) in respect of any one cause of loss or damage claimed to result from any breach of our obligations hereunder, shall be limited to actual money damages which shall not exceed £20,000 provided that such monetary limit shall not apply to any liability on the part of ourselves referred to in paragraph (a) above.

(d) except as provided in paragraph (a) above but otherwise notwithstanding any provision herein contained in no event shall we be liable for the following loss or damage howsoever caused and even if foreseeable by us or in our contemplation :-

(i) economic loss which shall include loss of profits, business revenue, goodwill or anticipated savings.

(ii) damages in respect of special indirect or consequential loss or damage (other than death, personal injury and damage to tangible property).

(iii) any claim made against the purchaser by any other party (save as expressly provided in paragraph (b) above).

(e) except in respect of our liability referred to in paragraph (a) above no claim may be made or action brought (whether in contract or in tort including negligence) by the purchaser in respect of any goods supplied by us more than one year after the date of the invoice for the relevant goods.

(f) nothing in these Conditions shall confer on the purchaser any rights or remedies to which the purchaser would not otherwise be legally entitled.

(6) Notwithstanding any other provision contained herein the Purchaser's hereby agree to fully indemnify us against any damages losses costs claims or expenses incurred by us in respect of any claim brought against us by any third party for :-

(a) any loss injury or damage wholly or partly caused by any goods supplied by us or their use.

(b) any loss injury or damage wholly or partly caused by the defective installation or sub-standard workmanship or materials used in the installation of any goods supplied by us.

(c) any loss injury or damage in any way connected with the performance of this contract.

PROVIDED that this paragraph (6) will not require the Purchaser to indemnify us against any liability for our own acts of negligence or those of our employees agents or sub-contractors.

FURTHER in the case of goods supplied by us which are re-sold to and installed by a third party by the Purchaser it will be the sole responsibility of the Purchaser to test the goods immediately after their installation to ensure that inter alia they are correctly installed and are in proper working order, and are not likely to cause any loss injury or damage to any person or property.

10. VARIATION OF WARRANTY AND EXCLUSION

Should our warranty and exclusion be unacceptable we are prepared to negotiate for variation in their terms but only on the basis of an increase in the price to allow for any additional liability or risk which may result from the variation.

Purchasers are advised to insure against any risk or liability which they may incur and which is not covered by our warranty.

11. RISK AND RETENTION OF TITLE

(a) goods supplied by us shall be at the Purchaser's risk immediately upon delivery to the Purchaser or into custody on the Purchaser's behalf or to the Purchaser's Order. The Purchaser shall effect adequate insurance of the goods against all risks to the full invoice value of the goods, such insurance to be effective from the time of delivery until property in the goods shall pass to the Purchaser as hereinafter provided.

(b) property in the goods supplied hereunder will pass to the Purchaser when full payment has been made by the Purchaser to us for :-

(i) the goods of the subject of this contract.

(ii) all other goods the subject of of any other contract between the Purchaser and us which, at the time of payment of the full price of the goods sold under this contract, have been delivered to the Purchaser but not paid for in full.

(c) until property in the goods supplied hereunder passes to the Purchaser in accordance with paragraph (2) above.

(i) the Purchaser shall hold the goods in a fiduciary capacity for us and shall store the same separately from any other goods in the Purchaser's possession and in a manner which enables them to be identified as our goods.

(ii) the Purchaser shall immediately return the goods to us should our authorised representative so request. All the necessary incidents associated with a fiduciary relationship shall apply.

(d) the Purchaser's right to possess the goods shall cease forthwith upon the happening of any of the following events, namely :-

(i) if the Purchaser fails to make payment in full for the goods within the time stipulated in clause 4 hereof.

(ii) if the Purchaser, not being a company, commits any act of bankruptcy, makes a proposal to his or her creditors for a compromise or does anything which would entitle a petition for a Bankruptcy Order to be presented.

(iii) if the Purchaser, being a company, does anything or fails to do anything which would entitle an administrator or an administrative receiver or a receiver to take possession of any assets or which would entitle any person to present a petition for winding up or to apply for an administration order.

(e) the Purchaser hereby grants to us an irrevocable licence to enter at any time any vehicle or premises owned or occupied by the Purchaser or in the possession of the Purchaser for the purposes of repossessing and recovering any such goods the property in which has remained in us under paragraph (2) above. We shall not be responsible for and the Purchaser will indemnify us against liability in respect of damage caused to any vehicle or premises in such repossession and removal being damaged which it was not reasonably practicable to avoid.

(f) notwithstanding paragraph (3) hereof and subject to paragraph (7) hereof, the Purchaser shall be permitted to sell the goods to third parties in the normal course of business. In this respect the Purchaser shall act in the capacity of our commission agent and the proceeds of such sale :-

(i) shall be held in trust for us in a manner which enables such proceeds to be identified as such, and :

(ii) shall not be mixed with other monies nor paid into an overdrawn bank account.

We, as principal, shall remunerate the Purchaser as commission agent a commission depending upon the surplus which the Purchaser can obtain over and above the sum, stipulated in this contract of supply which will satisfy us.

(g) in the event that the Purchaser shall sell any of the goods pursuant to clause (6) hereof, the Purchaser shall forthwith inform us in writing of such sale and of the identity and address of the third party to whom the goods have been sold.

(h) if, before property in the goods passes to the Purchaser under paragraph (2) above the goods are or become affixed to any land or building owned by the Purchaser it is hereby agreed and declared that such affixation shall not have the effect of passing property in the goods to the Purchaser. Further more if, before property in the goods shall pass to the Purchaser under paragraph (2) hereof, the goods are or become affixed to any land or building (whether or not owned by the Purchaser), the Purchaser shall :-

(i) ensure that the goods are capable of being removed without material injury to such land or building.

(ii) take all necessary steps to prevent title to the goods from passing to the landlord of such land or building.

(iii) forthwith inform us in writing of such affixation and of the address of the land or building concerned.

The Purchaser warrants to repair and make good any damage caused by the affixation of the goods to or their removal from any land or building and to indemnify us against all loss damage or liability we may incur or sustain as a result of affixation or removal.

(i) in the event that, before property in the goods has passed to the Purchaser under paragraph (2) hereof, the goods or any of them are lost, stolen, damaged or destroyed :-

(i) the Purchaser shall forthwith inform us in writing of the fact and circumstances of such loss, theft, damage or destruction.

(ii) the Purchaser shall assign to us the benefit of any insurance claim in respect of the goods so lost, stolen, damaged or destroyed.

12. NON-PAYMENT

If the Purchaser shall fail to make full payment for the goods supplied hereunder within the time stipulated in clause 4 hereof or be in default of payment for any other reason then, without prejudice to any of our other rights hereunder, we shall be entitled to stop all deliveries of goods and materials to the Purchaser, including deliveries or further deliveries of goods under this contract. In addition we shall be entitled to terminate all outstanding orders.

13. RISK

All goods sold by us shall be at the sole risk of the Purchaser from the date of despatch by us of the invoice for their price.

14. VALUE ADDED TAX

All prices quoted are exclusive of Value Added Tax which will be charged at the rate ruling at the date of despatch of invoice.

15. TRADE SALES ONLY

We are only prepared to deal with those who are not consumers within the terms of the Unfair Contract Terms Act 1977, the Sale of Goods Act 1979 and the Supply of Goods and Services Act 1982. Accordingly any person who purchases from us shall be deemed to have represented that he is not a consumer by so purchasing.

16. JURISDICTION

The Agreement is subject to English/Scots law and any dispute arising hereunder shall be settled in accordance therewith dependent upon the location.

