

GULFSTREAM 2000

DESIGN AND INSTALLATION MANUAL FOR THE ROOF TERMINAL FLUE KIT FOR PITCHED AND FLAT ROOFS

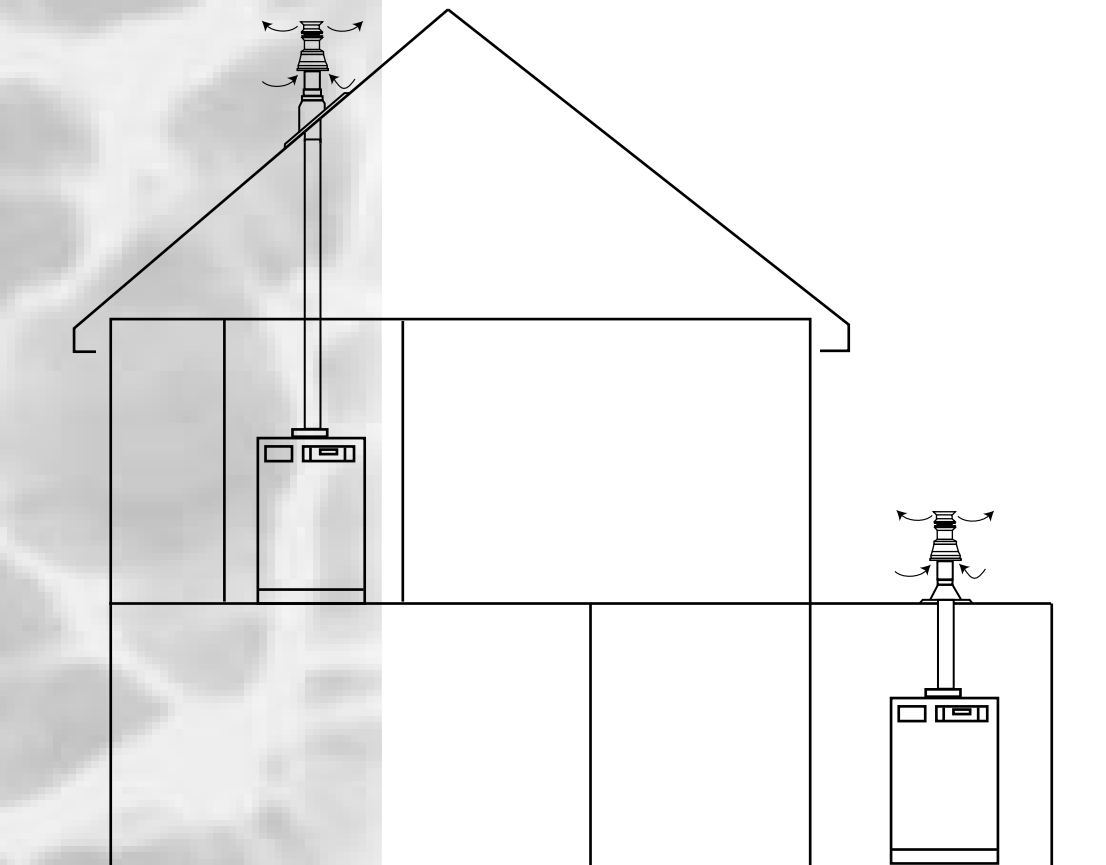

ROOF TERMINAL FLUE KIT G.C. NO



*The code of practice for the installation,
commissioning & servicing of central heating systems*

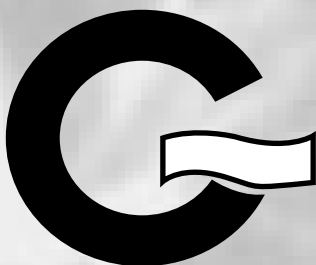

**THE GAS SAFETY (INSTALLATION AND USE)
REGULATIONS -**

**In your own interest and that of safety, it is
law that all gas appliances are installed by
competent persons and in accordance with the
above regulations.**

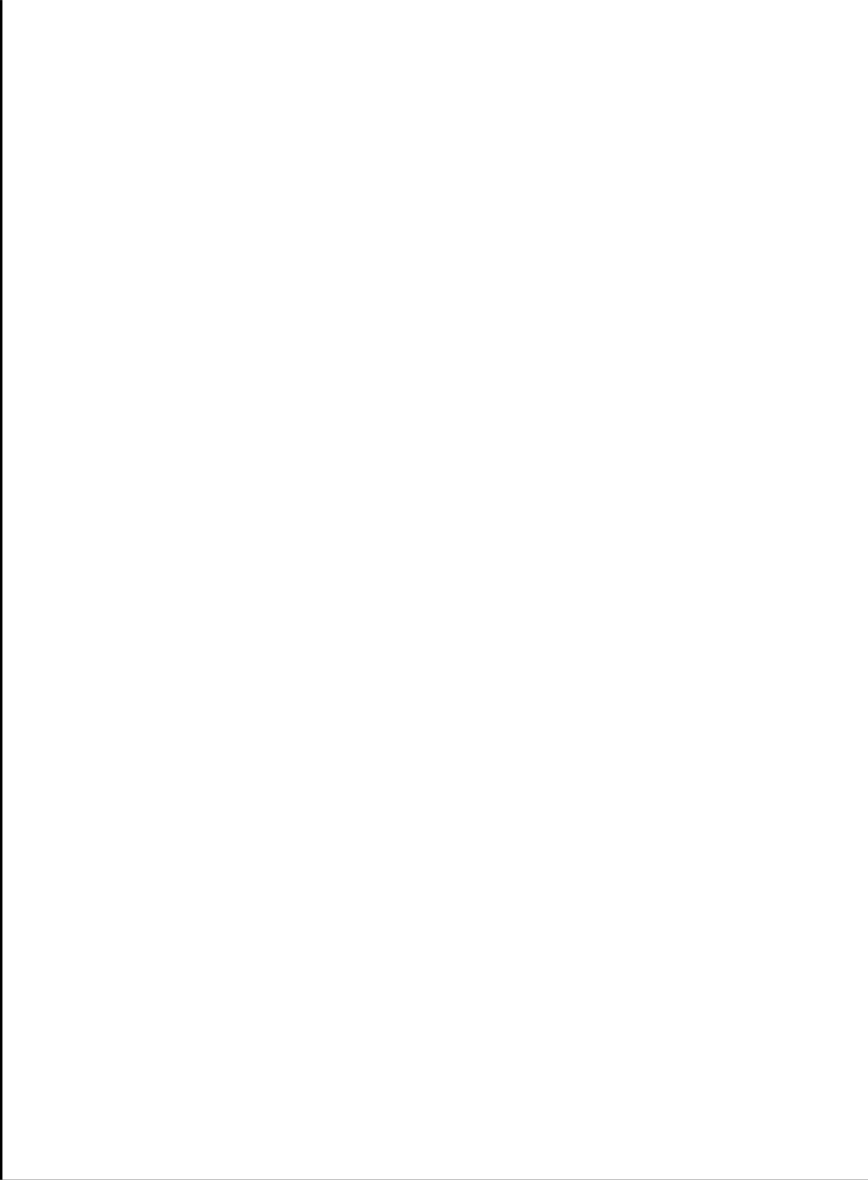

ISSUE 2: 10-02

1.0 INTRODUCTION

SECTION		PAGE
1.0	INTRODUCTION	3
2.0	DESCRIPTION	4
3.0	DESIGN/TECHNICAL	5
4.0	INSTALLATION	8
	TERMS & CONDITIONS	10

These instructions must be read in conjunction with the Design, Installation and Servicing instructions for the GulfStream²⁰⁰⁰

Any central heating flue installation must comply with the relevant recommendations of the current version of the Gas Safety (Installation and Use) Regulations, and the Building Regulations as well as any British and European Standards such as BS 5440:Part 1.

The information in this manual is provided to assist generally in the selection of equipment. The responsibility for the selection and specification of the equipment must however remain that of the customer and any designers or consultants concerned.

Please note: We do not therefore accept any responsibility for matters of design, selection or specification or for the effectiveness of an installation containing one of our products unless we have been specifically requested to do so.

All goods are sold subject to our Conditions of Sale, which are set out at the rear of this manual.

In the interest of continuously improving the GulfStream range, Gledhill Water Storage Ltd reserve the right to modify the product without notice, and in these circumstances this document, which is accurate at the time of printing, should be disregarded. It will however be updated as soon as possible after the change has occurred.

Note :

See separate manuals for details of the following flue kits which are also available.

1. Gable Terminal Flue Kit
2. Balanced Terminal Flue Kit
3. Ridge Terminal Flue Kit
4. Twin Pipe Horizontal Flue Kit

The Gledhill Group's first priority is to give a high quality service to our customers.

Quality is built into every Gledhill product and we hope you get satisfactory service from Gledhill.

If not please let us know.

ROOF TERMINAL FLUE KIT

FLUE COMPONENTS

* Concentric pipe and fittings are normally supplied in 60/100mm nominal epoxy finish.

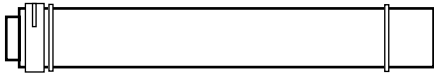

Concentric pipes - 0.5m / 1.0m long- with clamp

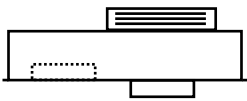

Concentric Boiler terminal conversion box with fixing screws

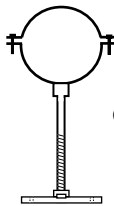

Concentric pipe support bracket

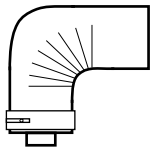

Concentric pipe 87/90° bend with clamp

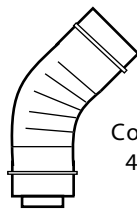

Concentric pipe 43°/45° bend with clamp

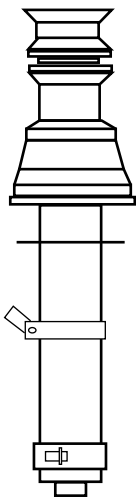

Concentric Roof Terminal with clamp

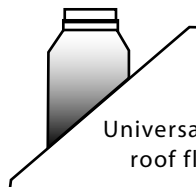

Universal pitched roof flashing

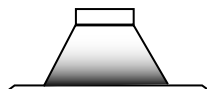

Flat roof flashing

2.0 DESCRIPTION

The balanced roof terminal flue system comprises a number of the push fit socketted concentric components (shown opposite), and is designed to allow air and the flue gases to be discharged to atmosphere through a suitable roof terminal.

The system is equally suitable for a pitched or flat roof and the standard kits available are shown opposite.

Because the Gulfstream²⁰⁰⁰ is a condensing appliance **the whole of the flue MUST be installed with a continuous minimum fall of 3° back to the boiler. (50mm/metre)**

It is important that the position and fixing of the roof terminal is checked and confirmed as suitable before the flue is installed.

It is also important that the flue terminal is located as near as practical to the GulfStream²⁰⁰⁰ appliance and the route of the flue is checked and clear of any roof trusses or other obstructions in the roofspace.

Note: An equivalent 80/125mm concentric flue system is also available. Please consult Gledhill Technical Department if this is considered necessary.

ROOF TERMINAL FLUE KIT

Standard Pitched Roof Terminal Flue Kit - AFG006		
Quantity	Description	Stock Code
1	60/100mm Concentric Conversion box T.C	GT268
1	60/100mm Shortable Concentric Flue Pipe - 0.5m	GT217
1	60/100mm Concentric Flue Pipe - 1.0m	GT213
2	60/100mm Concentric Pipe Flue Bend - 43/ 45°	GT275
1	60/100mm Concentric Roof Terminal	GT216
1	60/100mm Universal pitched roof flashing	GT261
3	60/100 Concentric pipe bracket	GF215
Standard Flat Roof Terminal Flue Kit - AFG040		
1	60/100mm Concentric Conversion box T.C.	GT268
1	60/100mm Shortable Concentric Flue Pipe - 0.5m	GT217
1	60/100mm Concentric Roof Terminal	GT216
1	60/100mm Concentric flat roof flashing	GT293
1	60/100 Concentric pipe bracket	GF215
Additional Flue Components Available		
-	60/100mm Concentric Pipe Flue Bends - 87/90°	GT218
-	60/100mm to 80/125mm Concentric Adaptor	GF208
-	80/125mm Concentric bracket	GF209
-	80/125mm Concentric roof terminal	GF210
-	80/125mm Universal pitched roof flashing	GF211
-	80/125mm Flat roof flashing	GF212
-	80/125mm Concentric Pipe Flue Bends 43/45°	GF213
-	80/125mm Concentric Pipe Flue Bends 87/90°	GF214
-	80/125 Shortable Concentric Flue Pipe 0.5m	GF206
-	80/125mm Concentric Flue Pipe - 1.0m	GF207

3.0 DESIGN/TECHNICAL

The standard pitched roof terminal flue kit, (stock code no. AFG006) is based on the 60/100mm concentric flue system components shown opposite.

The standard kit should cover the majority of typical installations. However separate extra components can be ordered using the individual stock codes shown if required.

The maximum air/flue length which can be used must not exceed an equivalent length specified in the table on page 6.

Flues should generally be installed in accordance with BS 5440 : Part 1.

The roof terminal is the balanced type and provides air for combustion as well as an outlet for the flue gases.

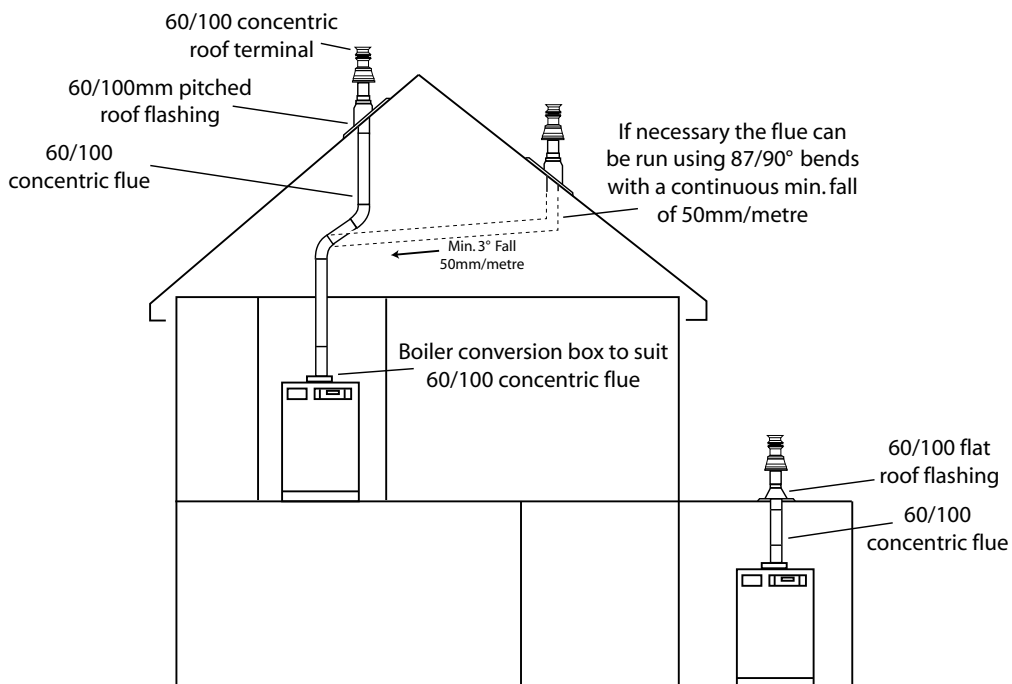

ROOF TERMINAL FLUE KIT

3.0 DESIGN/TECHNICAL

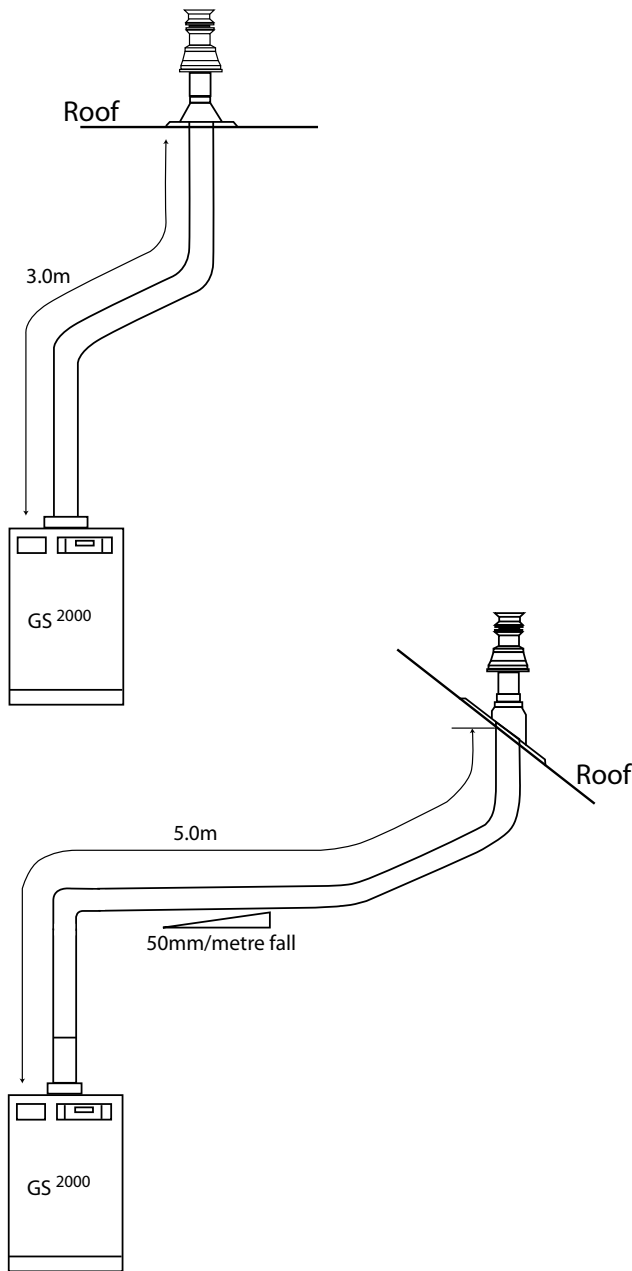

Two examples of how to calculate the equivalent flue length for the typical 60mm diameter flue system installations shown opposite, using the Table below, is as follows.

1. Concentric flue pipe length
 $4.0\text{m} \times 2 = 8.0\text{m}$

Equivalent length of fittings
 $2 \times 45^\circ \text{ bends} \times 3.0\text{m} = 6.0\text{m}$

Total equivalent flue length
 $8.0 + 6.0 = 14\text{m}$

If the flue needs to run along the roof space before rising, this would be calculated as follows.

2. Concentric flue pipe length
 $5.0\text{m} \times 2 = 10.0\text{m}$

Equivalent length of fittings
 $1 \times 90^\circ \text{ bend} \times 3.8\text{m} = 3.8\text{m}$
 $2 \times 45^\circ \text{ bend} \times 3.0\text{m} = 6.0\text{m}$

Total equivalent flue length
 $10.0 + 3.8 + 6.0 = 19.8\text{m}$

As the equivalent flue length calculated for the 60/100 system is above the 17m maximum equivalent flue length allowed, the same calculation must be carried out for the 80mm system and if this is below the 60m maximum equivalent flue length this should be used.

As long as the flue pipework always runs back to the boiler at a minimum fall of 50mm/metre, any pipework configuration can be used as long as the equivalent total air/flue length is less than the maximum equivalent flue length shown in the Table below for the size of flue system being used.

Equivalent Flue Length Table		
	60mm System	80mm System
Maximum equivalent flue length (m)	17m	60m
60/100 Concentric flue pipe	2.0	-
80/125 Concentric flue pipe	-	2.0
90° Elbow	3.8	10.6
45° Elbow	3.0	8.0

ROOF TERMINAL FLUE KIT

3.0 DESIGN / TECHNICAL

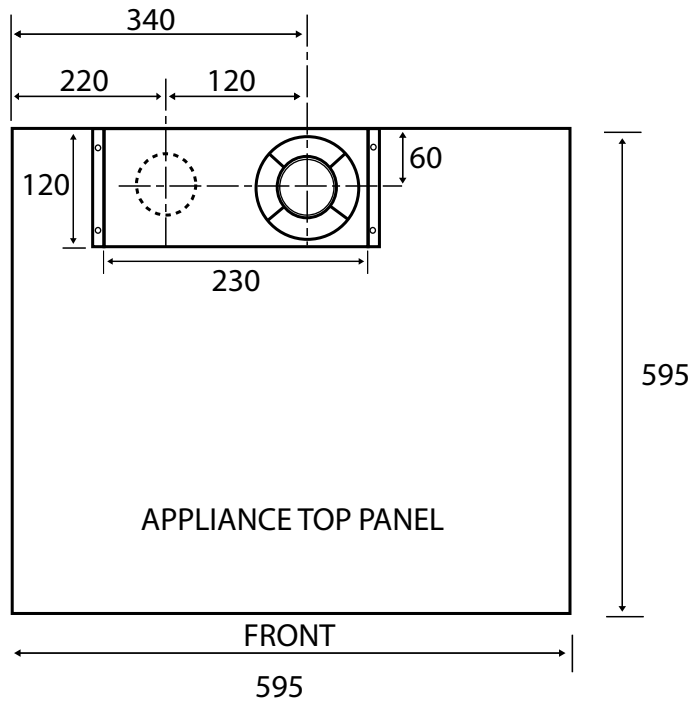

All dimensions are in mm

The location of the air inlet and flue/exhaust connections on the appliance are shown opposite. Each connection is provided with a push fit socket and is labelled.

Note: It is the installers responsibility to check that the roof flashing is suitable for the roof covering/tile being used.

The appliance location itself should have been chosen to comply with the relevant requirements of the GulfStream²⁰⁰⁰ Design Installation and Servicing Instructions.

When terminating the flue adjacent to an opening in a pitched or flat roof these must be positioned in accordance with the requirements shown opposite.

The concentric flue pipe used in the appliance cupboard means that the flue can be safely touched or clothes/towels etc. can be stored next to the flue and can pass into the roof space close to combustible material without any extra protection/insulation being required.

If the flue is run through a timber wall or cupboard, the concentric flue will automatically provide the necessary protection and a further air gap/insulation is not required.

Recommendations on protection of combustible material are given in BS 5440 : Part 2 : Clause 20.

ROOF TERMINAL FLUE KIT

4.0 INSTALLATION

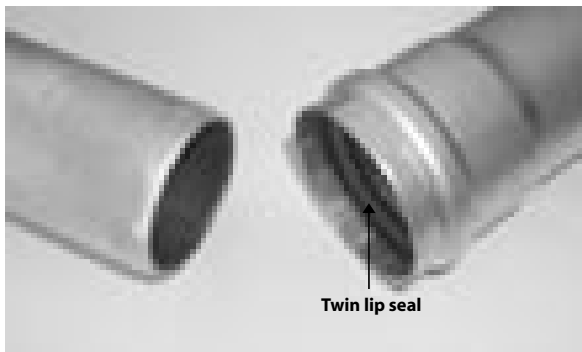

Make sure the appliance is in the correct position before commencing installation of the air/flue pipes.

The flue pipes must be assembled with the plain end of pipe (or fitting) nearest the appliance and the socket end furthest from the appliance.

Always adjust length of pipes by cutting the plain end. We would strongly recommend that a pipe cutter is used to cut the internal flue pipe which will reduce the possibility of any damage to the twin lip seal when making the joint.

The external flue pipe can be cut using a hacksaw as long as all burrs inside and outside are removed.

Keep the outside of the flue pipes clean and free of oil or grease.

Do not use any sealant or lubricant other than water.

When cutting the flue pipe it is essential that the inner flue must be left protruding by exactly 20mm (plain end).

Any generally horizontal run of flue pipe must have a fall of at least 50mm/metre back to the boiler and must not be allowed to dip, i.e. fall below the horizontal or form a low point at which condensate could accumulate.

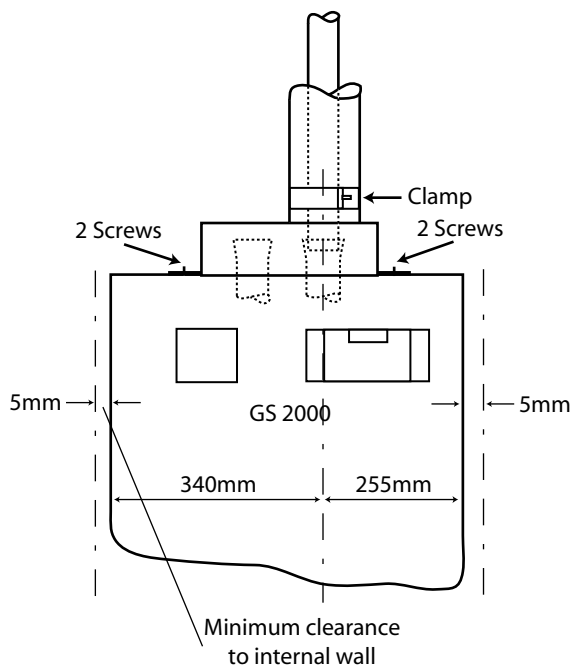

ROOF TERMINAL FLUE KIT

4.0 INSTALLATION

The roof terminal should be installed as follows - see sketches opposite;

1. Check the flue terminal for any damage

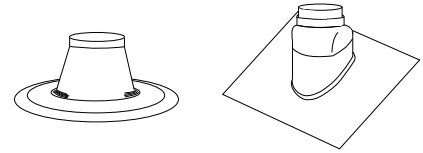

Flat roof flashing **Universal pitched roof flashing**

2. Taking the roofing into account check the type of weather collar is correct. For a tiled pitched roof use universal pitched roof flashing or for a flat roof an aluminium flat roof flashing.

Note: The universal pitched roof flashing is adjustable to suit all roof pitches from 25° to 40°.

3. Determine where the flue terminal will be positioned and plan the route of the flue.

4. Make a hole for the flue terminal. Ensure that no saw dust or dust gets into the boiler.

5. Fit the weather collar on the roof.

6. Carefully insert the flue terminal through the roof from the outside. Attention: do not turn the cap.

7. Put the flue terminal into a vertical position using an air level. (If desired, cover plates, to be supplied separately, can be fitted internally).

8. Fix the wall clamp supplied round the flue terminal and fit it to the roof construction. Do not tighten the clamp at this stage.

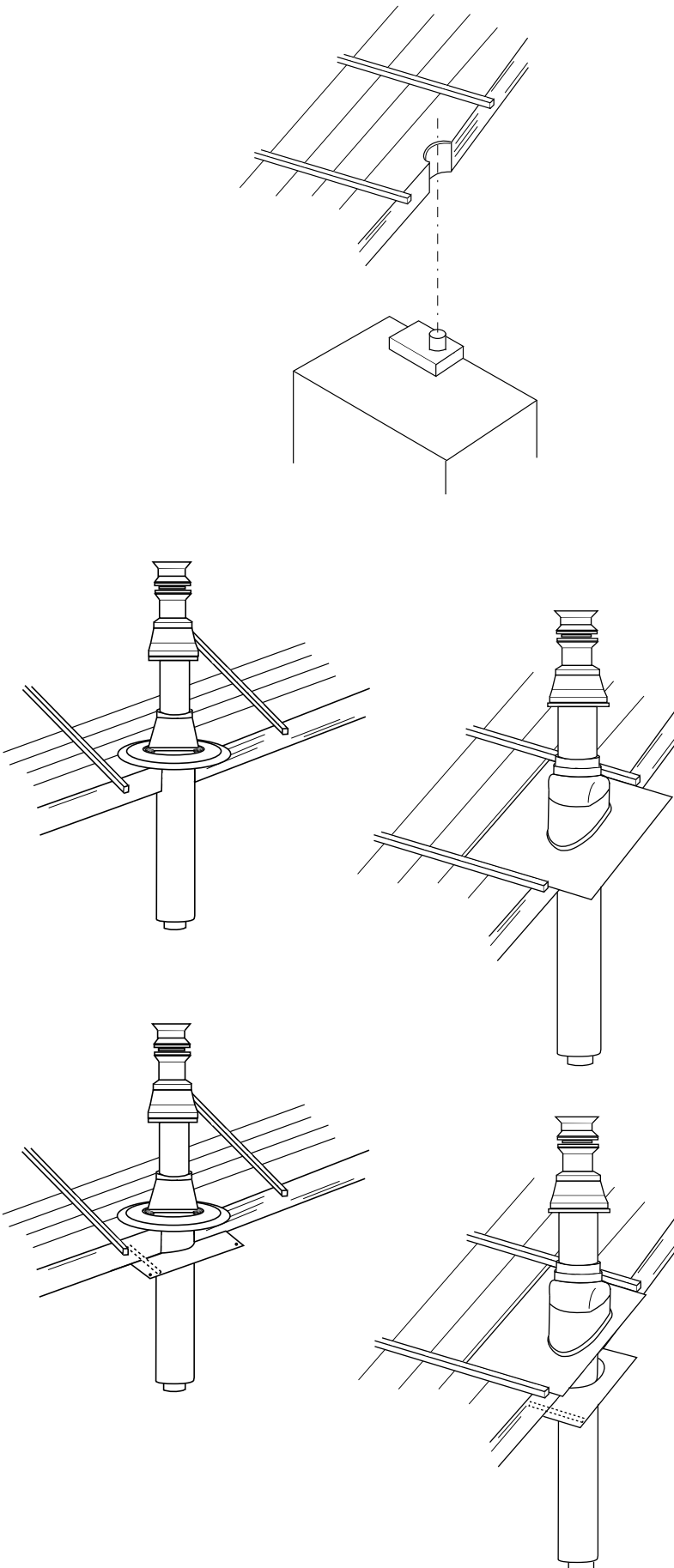

4.0 INSTALLATION

The standard flue kit should be installed as follows ;

1. Push the concentric boiler conversion box firmly into the sockets provided on the appliance ensuring the flue and air inlet are not exchanged. (The connections are labelled and when installed correctly the flue pipe socket on the appliance will be directly below the flue pipe connection on the adaptor), see diagram opposite. Fix in position on the appliance using the 4 screws provided.

2. Fit a 1000mm length of concentric pipe to the adaptor using the clamp provided on the outside joint. Ensure the inner flue joint is pushed fully home.

3. Repeat the above procedure for any further pipes/bends etc. until the pipework extends to the roof terminal, (temporarily support/secure the pipe if necessary). Measure and cut any pipes as necessary. Be sure to follow the earlier instructions when cutting pipes/making joints.

4. Connect the roof terminal to the pipework. Ensure the vertical pipework is adequately supported at the connection to the roof terminal.

5. Visually inspect and check each joint is pushed home fully. Ensure the flue also has a minimum continuous fall back to the boiler of 50mm/metre.

6. Permanently secure the flue pipes at approximately 1 metre centres. Ensure a bracket is provided adjacent to each joint on horizontal pipes.

7. Check the joint between the roof terminal and flashing is watertight and secure the roof wall clamp.

Note : The flue pipe must **not** rely on the roof terminal for support.

It is the responsibility of the installer to ensure that the flue installation through the roof is weatherproof i.e no rain must ingress into dwelling roof space.

1. We only do business upon the Conditions which appear below and no other. Unless we so agree in writing these Conditions shall apply in full to any supply of goods by us to the exclusion of any Conditions or terms sought to be imposed by any purchaser. These Conditions of Sale and Warranty Terms override those which are contained on the Invoice Forms and all Sales are now subject to these Conditions of Sale and Warranty terms only.

2. PRICE

Orders are accepted at the price ruling at the date of receipt of order, this price is our last published list price plus a supplement to allow for any increase in the price of copper between the dates of publication of our price lists ("the copper price supplement"). An order may not be cancelled or varied after acceptance without the written consent of the company. Such cancellation or variation shall be subject to such reasonable charges as may be appropriate.

3. SPECIFICATION

The goods are supplied in accordance with the Specifications (if any) submitted to the Purchaser and any additions and alterations shall be the subject of an extra charge. Any goods not so specified shall be in accordance with our printed literature or the literature of any of our component suppliers (subject to any modifications made since publication). If we adopt any changes in construction or design of the goods, or in the specification printed in our literature, the Purchaser shall accept the goods so changed in fulfilment of the order.

4. PAYMENT

The invoice price of goods shall be payable within 30 days of despatch by us of our invoice for the goods or such longer time as may be stated by our quotation or invoice. If we receive payment in full on or before the due date we will allow a discount of 5% except where we have quoted a special net price. If payment is not received in full on or before the due date we shall be entitled in addition to the invoice price to:

- (i) payment of a sum equal to any increase in the copper price supplement applicable to the particular goods sold between the date of receipt of order and the date of receipt of payment in full; and
- (ii) interest on any part of the invoice price unpaid after the due date at the rate of 3% per annum over the base rate for the time being of Midland Bank plc.

5. TIME

We give estimates of delivery dates in good faith and time of delivery is not nor shall be made of the essence of any contract nor shall we be liable for any loss or damage occasioned by delay in delivery.

6. DELIVERY

We deliver free normally by our own vehicles within 25 miles of any of our manufacturing depots. Delivery to any place more than 25 miles from one of our manufacturing depots is subject to our quoted delivery charges. We reserve the right to make delivery of goods contained in one order by more than one consignment and at different times. Where a period is agreed for delivery and such period is not extended by our Agreement, the Purchaser shall take delivery within that period. If the Purchaser fails to take delivery, we shall be entitled at the Purchaser's risk and expense to store the goods at the Purchaser's premises or elsewhere and to demand payment as if they had been despatched. Offloading at point of delivery shall be the responsibility of and be undertaken by the Purchaser.

7. SHORTAGES OR DAMAGE

Goods must be inspected before signature of delivery note and any damage, shortage or discrepancy noted on the delivery note and the goods returned on the same vehicle. The buyer must also give us immediate written notice of the damage, shortage or discrepancy so that we may prompt investigation.

8. RETURN OF GOODS

Goods may not be returned to the Company except by prior written permission of an authorised officer of the Company and such return shall be subject to payment by the Purchaser of handling and re-stocking charges, transport and all other costs incurred by the Company.

9. COMPANY LIABILITY

ALL OUR GOODS ARE MADE OF THE BEST MATERIALS FROM REPUTABLE MANUFACTURERS AND WHERE STATED ARE MANUFACTURED TO THE APPROPRIATE BRITISH STANDARD. COMPLAINTS MUST BE GIVEN TO US IMMEDIATELY, BEFORE ANY ACTION IS TAKEN, AS RESPONSIBILITY CANNOT BE ACCEPTED IF REPAIRS OR RENEWALS ARE ATTEMPTED ON SITE WITHOUT OUR WRITTEN AUTHORITY.

Where we agree to rectify any defect, we reserve the right to undertake the work on our own premises. Provided that our product has been installed in accordance with any instructions for installation any any relevant codes of practice and in accordance with the bye-laws and requirements obtaining in any particular area we give the following warranties:

(1) Domestic and Commercial Open Vented Cylinders and Tanks.

If the copper cylinder or tank or any integral pipework proves to be defective either in materials or workmanship, we will either repair or supply replacement at our option with the closest substitute in the case of any obsolete product to any address in Great Britain.

- (a) free of all charge during the first year after delivery by us.
- (b) thereafter at a charge of one-tenth of the then current list price and any copper price supplement and delivery charge during the second year after delivery by us and increasing by a further one-tenth on the second and subsequent anniversary of delivery by us.

AND FURTHER WE WILL MEET THE CONTRACTORS/INSTALLERS REASONABLE COSTS IN REMOVING AND REPLACING ANY DEFECTIVE OPEN VENTED COPPER CYLINDER OR TANK WITH DEFECTIVE INTEGRAL PIPEWORK AS FOLLOWS:

- (i) in the case of vessels of less than 80 imperial gallons capacity up to a maximum of one-half of the extent of our liability in regard to the replacement product expressed in (1) (a) and (b) above
- II) IN THE CASE OF VESSELS LARGER THAN 79 IMPERIAL GALLONS CAPACITY UP TO A MAXIMUM OF ONE-QUARTER OF THE EXTENT OF OUR LIABILITY IN REGARD TO THE REPLACEMENT PRODUCT AS EXPRESSED IN PARAGRAPHS (1) (A) AND (B) ABOVE.

(2) Domestic Mains Fed Products

If the copper storage vessel itself or any integral pipework as part of the storage vessel assembly proves to be defective either in materials or workmanship, we reserve the right to either repair or supply replacements or the closest possible substitute in the case of any obsolete product and will collect and deliver to any address in England, Wales and Scotland (excluding all Scottish Islands).

- (a) free of all charge during the first year after delivery by us.

- (b) thereafter at a charge of one-fifth of the then current list price or any copper price supplement and delivery charge during the second year after delivery by us increasing by a further one-fifth on the second and subsequent anniversary of delivery by us.

AND FURTHER we will meet the contractors/installers reasonable costs in removing and replacing any defective copper storage vessel or storage vessel with defective integral pipework from the Domestic Mains Pressure Range of products up to a maximum of one-third of the extent of our liability in regard to the replacement product expressed in (2) (a) and (b) above.

- (3) Components of our products other than Storage Vessels and Integral Pipework. We will either extend to the purchaser the same terms of warranty as we are given by the manufacturer of the component or if the manufacturer does not give any warranty, replace free of charge any component which becomes defective within twelve months after the date of the delivery by us and is returned to us at the purchaser's expense but we shall not meet the cost of removal or shipping or return of the component or any other cost charges or damages incurred by the purchaser.

- (4) In the case of the Gulfstream range of products any heat generator found to be defective and admitted to be such by us either as regards materials or workmanship within 12 months from date of installation or 18 months from date of manufacture whichever is the sooner, will be repaired or replaced at our option. AND FURTHER we will meet the contractors/installers reasonable costs in removing and replacing any defective heat generator up to a maximum of one-third of the extent of our liability in regard to the replacement product.

- (5) In the case of goods manufactured solely in accordance with our specification and designs and in respect of any installation work carried out by or on our behalf, our entire liability and the purchaser's sole remedies (subject to (1-4) above) and shall be as follows:

- (a) we accept liability for death or personal injury to the extent that it results from our negligence that of our employees agents or subcontractors.
- (b) subject to paragraph (d) below, we accept liability for direct physical damage to tangible property to the extent that such damage is caused by our negligence that of our employees agents or subcontractors.
- (c) our total liability to the purchaser over and above any liability to replace under (1 - 4) above (whether in contract or in tort including negligence) in respect of any one cause of loss or damage claimed to result from any breach of our obligations hereunder, shall be limited to actual money damages which shall not exceed £20,000 provided that such monetary limit shall not apply to any liability on the part of ourselves referred to in paragraph (a) above.
- (d) except as provided in paragraph (a) above but otherwise notwithstanding any provision herein contained in no event shall we be liable for the following loss or damage howsoever caused and even if foreseeable by us or in our contemplation :-
 - (i) economic loss which shall include loss of profits, business revenue, goodwill or anticipated savings.
 - (ii) damages in respect of special indirect or consequential loss or damage (other than death, personal injury and damage to tangible property).
 - (iii) any claim made against the purchaser by any other party (save as expressly provided in paragraph (b) above).
- (e) except in respect of our liability referred to in paragraph (a) above no claim may be made or action brought (whether in contract or in tort including negligence) by the purchaser in respect of any goods supplied by us more than one year after the date of the invoice for the relevant goods.

(f) nothing in these Conditions shall confer on the purchaser any rights or remedies to which the purchaser would not otherwise be legally entitled.

(6) Notwithstanding any other provision contained herein the Purchaser's hereby agree to fully indemnify us against any damages losses costs claims or expenses incurred by us in respect of any claim brought against us by any third party for :-

(a) any loss injury or damage wholly or partly caused by any goods supplied by us or their use.

(b) any loss injury or damage wholly or partly caused by the defective installation or sub-standard workmanship or materials used in the installation of any goods supplied by us.

(c) any loss injury or damage in any way connected with the performance of this contract.

PROVIDED that this paragraph (6) will not require the Purchaser to indemnify us against any liability for our own acts of negligence or those of our employees agents or sub-contractors.

FURTHER in the case of goods supplied by us which are re-sold to and installed by a third party by the Purchaser it will be the sole responsibility of the Purchaser to test the goods immediately after their installation to ensure that inter alia they are correctly installed and are in proper working order, and are not likely to cause any loss injury or damage to any person or property.

10. VARIATION OF WARRANTY AND EXCLUSION

Should our warranty and exclusion be unacceptable we are prepared to negotiate for variation in their terms but only on the basis of an increase in the price to allow for any additional liability or risk which may result from the variation.

Purchasers are advised to insure against any risk or liability which they may incur and which is not covered by our warranty.

11. RISK AND RETENTION OF TITLE

(a) goods supplied by us shall be at the Purchaser's risk immediately upon delivery to the Purchaser or into custody on the Purchaser's behalf or to the Purchaser's Order. The Purchaser shall effect adequate insurance of the goods against all risks to the full invoice value of the goods, such insurance to be effective from the time of delivery until property in the goods shall pass to the Purchaser as hereinafter provided.

(b) property in the goods supplied hereunder will pass to the Purchaser when full payment has been made by the Purchaser to us for :-

(i) the goods of the subject of this contract.

(ii) all other goods the subject to of any other contract between the Purchaser and us which, at the time of payment of the full price of the goods sold under this contract, have been delivered to the Purchaser but not paid for in full.

(c) until property in the goods supplied hereunder passes to the Purchaser in accordance with paragraph (2) above.

(i) the Purchaser shall hold the goods in a fiduciary capacity for us and shall store the same separately from any other goods in the Purchaser's possession and in a manner which enables them to be identified as our goods.

(ii) the Purchaser shall immediately return the goods to us should our authorised representative so request. All the necessary incidents associated with a fiduciary relationship shall apply.

(d) the Purchaser's right to possess the goods shall cease forthwith upon the happening of any of the following events, namely :-

(i) if the Purchaser fails to make payment in full for the goods within the time stipulated in clause 4 hereof.

(ii) if the Purchaser, not being a company, commits any act of bankruptcy, makes a proposal to his or her creditors for a compromise or does anything which would entitle a petition for a Bankruptcy Order to be presented.

(iii) if the Purchaser, being a company, does anything or fails to do anything which would entitle an administrator or an administrative receiver or a receiver to take possession of any assets or which would entitle any person to present a petition for winding up or to apply for an administration order.

(e) the Purchaser hereby grants to us an irrevocable licence to enter at any time any vehicle or premises owned or occupied by the Purchaser or in the possession of the Purchaser for the purposes of repossessing and recovering any such goods the property in which has remained in us under paragraph (2) above. We shall not be responsible for and the Purchaser will indemnify us against liability in respect of damage caused to any vehicle or premises in such repossession and removal being damaged which it was not reasonably practicable to avoid.

(f) notwithstanding paragraph (3) hereof and subject to paragraph (7) hereof, the Purchaser shall be permitted to sell the goods to third parties in the normal course of business. In this respect the Purchaser shall act in the capacity of our commission agent and the proceeds of such sale :-

(i) shall be held in trust for us in a manner which enables such proceeds to be identified as such, and :

(ii) shall not be mixed with other monies nor paid into an overdrawn bank account.

We, as principal, shall remunerate the Purchaser as commission agent a commission depending upon the surplus which the Purchaser can obtain over and above the sum, stipulated in this contract of supply which will satisfy us.

(g) in the event that the Purchaser shall sell any of the goods pursuant to clause (6) hereof, the Purchaser shall forthwith inform us in writing of such sale and of the identity and address of the third party to whom the goods have been sold.

(h) if, before property in the goods passes to the Purchaser under paragraph (2) above the goods are or become affixed to any land or building owned by the Purchaser it is hereby agreed and declared that such affixation shall not have the effect of passing property in the goods to the Purchaser. Furthermore if, before property in the goods shall pass to the Purchaser under paragraph (2) hereof, the goods are or become affixed to any land or building (whether or not owned by the Purchaser), the Purchaser shall:-

(i) ensure that the goods are capable of being removed without material injury to such land or building.

(ii) take all necessary steps to prevent title to the goods from passing to the landlord of such land or building.

(iii) forthwith inform us in writing of such affixation and of the address of the land or building concerned.

The Purchaser warrants to repair and make good any damage caused by the affixation of the goods to or their removal from any land or building and to indemnify us against all loss damage or liability we may incur or sustain as a result of affixation or removal.

(i) in the event that, before property in the goods has passed to the Purchaser under paragraph (2) hereof, the goods or any of them are lost, stolen, damaged or destroyed :-

(i) the Purchaser shall forthwith inform us in writing of the fact and circumstances of such loss, theft, damage or destruction.

(ii) the Purchaser shall assign to us the benefit of any insurance claim in respect of the goods so lost, stolen, damaged or destroyed.

12. NON-PAYMENT

If the Purchaser shall fail to make full payment for the goods supplied hereunder within the time stipulated in clause 4 hereof or be in default of payment for any other reason then, without prejudice to any of our other rights hereunder, we shall be entitled to stop all deliveries of goods and materials to the Purchaser, including deliveries or further deliveries of goods under this contract. In addition we shall be entitled to terminate all outstanding orders.

13. RISK

All goods sold by us shall be at the sole risk of the Purchaser from the date of despatch by us of the invoice for their price.

14. VALUE ADDED TAX

All prices quoted are exclusive of Value Added Tax which will be charged at the rate ruling at the date of despatch of invoice.

15. TRADE SALES ONLY

We are only prepared to deal with those who are not consumers within the terms of the Unfair Contract Terms Act 1977, the Sale of Goods Act 1979 and the Supply of Goods and Services Act 1982. Accordingly any person who purchases from us shall be deemed to have represented that he is not a consumer by so purchasing.

16. JURISDICTION

The agreement is subject to English/Scots law and any dispute arising hereunder shall be settled in accordance therewith dependent upon the location.

