

# SYSTEMATE 2000

## DESIGN, INSTALLATION AND SERVICING INSTRUCTIONS

PLEASE LEAVE THESE INSTRUCTIONS IN THE POCKET PROVIDED ON  
THE BACK OF THE FRONT PANEL

### Gas Council Approved Reference Numbers

SysteMate 125 97-317-26  
SysteMate 145 97-317-27  
SysteMate 185 97-317-28  
SysteMate 210 97-317-29  
SysteMate 225 97-317-30



*The code of practice for the installation,  
commissioning & servicing of central heating systems*

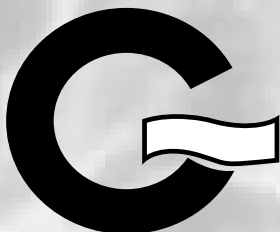

**A SEALED CENTRAL HEATING  
AND MAINS PRESSURE HOT WATER SUPPLY  
SYSTEM INCORPORATING  
A THERMAL STORE**

**ALL MODELS COMPLY WITH THE  
WATER HEATER MANUFACTURERS  
SPECIFICATION FOR HOT WATER  
ONLY THERMAL STORES**

# CONTENTS

## ISSUE 7 : 01-03

Section	Page
<b>1.0 DESIGN</b>	
1.1 Introduction	3
1.2 Technical Data	5
1.3 System Details	10
<b>2.0 INSTALLATION</b>	
2.1 Site Requirements	16
2.2 Installation	17
2.3 Commissioning	25
<b>3.0 SERVICING</b>	
3.1 Annual Servicing	29
3.2 Changing Components	29
3.3 Short Parts List	30
3.4 Fault Finding	32
Appendix 'A'	34
Appendix 'B'	35
Terms & Conditions	38



*The code of practice for the installation,  
commissioning & servicing of central heating systems*

As part of the industry wide "Benchmark" Initiative all Gledhill Systemates now include a Benchmark Installation, Commissioning and Service Record Log Book. Please read carefully and complete all sections relevant to the appliance installation. The details of the Log Book will be required in the event of any warranty work being required. There is also a section to be completed after each regular service visit. **The completed Log Book and these instructions should be left in the pocket provided on the back of the front panel.**

**The Gledhill Systemate 2000 range is a WBS listed product and complies with the WMA Specification for hot water only thermal storage products. The principle was developed in conjunction with British Gas. This product is manufactured under a BS EN ISO 9002 Quality System audited by BSI.**

**Patents Pending**

**The Gledhill Group's first priority is to give a high quality service to our customers.**

**Quality is built into every Gledhill product and we hope you get satisfactory service from Gledhill.**

**If not please let us know.**

# 1.0 DESIGN

## 1.1 INTRODUCTION

These instructions should be read in conjunction with the Installation and Servicing Instructions issued by the manufacturers of the heat source e.g. the boiler used.

Any water distribution and central heating installation must comply with the relevant recommendations of the current version of the Regulations and British Standards listed below:-

Gas Safety Regulations  
Building Regulations  
I.E.E. Requirements for Electrical Installations  
Water Regulations

### British Standards

BS6798, BS5449, BS5546, BS5440:1, BS5440:2, CP331:3, BS6700, BS5258, BS7593 and BS7671.

A competent person as stated in the Gas Safety Regulations must install the SystemeMate 2000 heating system. The manufacturer's notes must not be taken as overriding statutory obligations.

The SystemeMate 2000 is only suitable for use with a sealed primary, i.e. central heating, system.

The SystemeMate 2000 is not covered by section G3 of the current Building Regulations and is therefore not notifiable to Building Control.

The information in this manual is provided to assist generally in the selection of equipment. The responsibility for the selection and specification of the equipment must however remain that of the customer and any Designers or Consultants concerned with the design and installation.

**Please Note:** We do not therefore accept any responsibility for matters of design, selection or specification or for the effectiveness of an installation containing one of our products unless we have been specifically requested to do so.

All goods are sold subject to our Conditions of Sale, which are set out at the rear of this manual.

In the interest of continuously improving the SystemeMate range, Gledhill Water Storage Ltd reserve the right to modify the product without notice, and in these circumstances this document, which is accurate at the time of printing, should be disregarded. It will however be updated as soon as possible after the change has occurred.



# 1.0 DESIGN

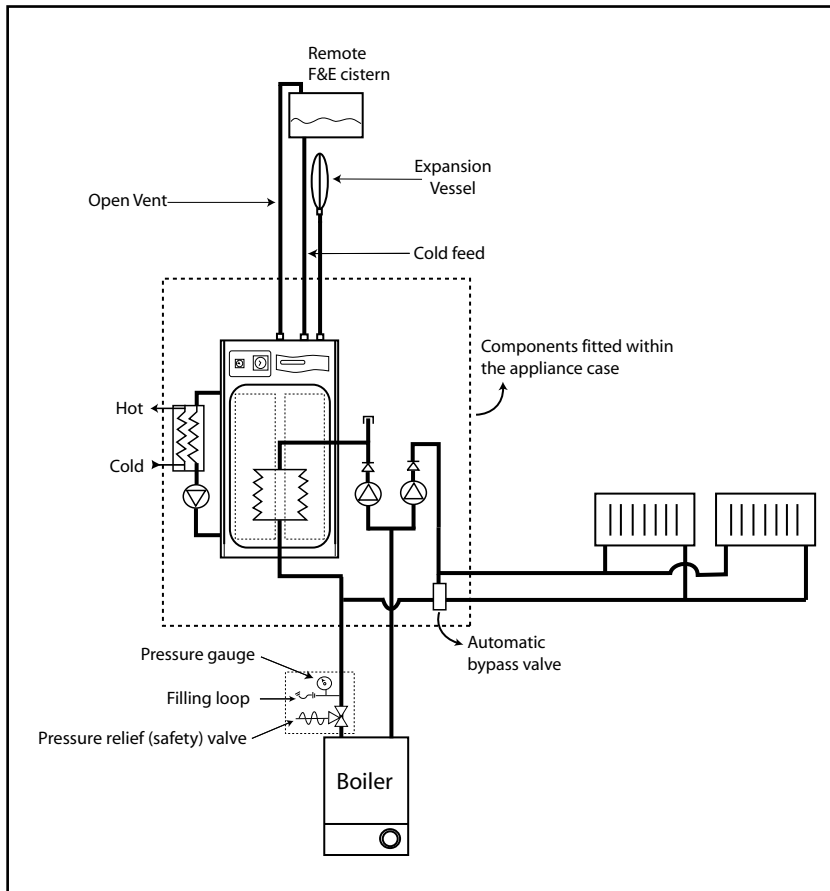

An important feature of this product is that hot water can be supplied directly from the mains at conventional flow rates without the need for temperature and pressure relief safety valves or expansion vessels. This is achieved by passing the mains water through a plate heat exchanger. The outlet temperature of the domestic hot water is maintained by a printed circuit board, which controls the speed of the pump circulating the primary water from the store through the plate heat exchanger.

Because of the innovative method of hot water production no in-line scale reducer is normally required on the cold supply to the appliance.

If scale should become a problem the plate heat exchanger is easily isolated and replaced with a service exchange unit.

The whole system is controlled by a special electronic control p.c.b. complete with programmer to which an external room thermostat can be easily connected.

The pcb also incorporates the facility to operate the heating pump for a few seconds every few days when the heating is not being used, to reduce the likelihood of the pumps sticking as well as providing a boiler pump overrun facility.

Any sealed system automatic boiler designed to operate on an 82°C flow and a 71°C return up to a maximum of 35kW can be linked to any suitable model of Systemate 2000 and the deciding factor is the space heating and the hot water requirements of a dwelling. See Section 1.2 Technical Data for further details.

The Systemate 2000 is available with the option of 'Switch' which will provide a 9kW electrical emergency backup in case of failure of the main heat source. See section 1.3 System Details for further information.

There is no facility available to incorporate a standard 3kW immersion heater for back up hot water only.

Gledhill are part of the 'Benchmark' scheme and a separate commissioning/service log book is included with the product.

## 1.1 INTRODUCTION

### Description

The Systemate 2000 shown schematically above is designed to provide sealed system space heating and mains pressure hot water at high flow rates when coupled to any remotely sited, condensing or non condensing, boiler suitable for sealed heating systems.

The Systemate 2000 is an indirectly heated hot water only thermal store and is supplied with the factory fitted controls and equipment shown in Section 1.2 Technical Data.

The indirect heat exchanger is highly efficient and designed to provide extremely quick hot water recovery as well as back-up space heating when using 'Switch'.

For details of how to produce SAP ratings calculations contact Gledhill Technical Department.

**Because the F & E cistern is only used to fill the thermal store the standard appliance is supplied as a manual fill model, i.e, without a ballvalve and overflow, which makes it particularly suitable for use in flats/apartments. A ballvalve and overflow fitting can be supplied as an optional extra if required.**

# 1.0 DESIGN

## 1.2 TECHNICAL DATA

Model	SM 125	SM 145	SM 185	SM 210	SM 225			
Weight (empty)	65kg	68kg	72kg	89kg	101kg			
Weight (full)	180kg	193kg	222kg	259kg	291kg			
DHW Pump	Grundfos 15/50	Grundfos 15/50	Grundfos 15/50	Grundfos 15/50	Grundfos 15/50			
Heating Pump	Grundfos 15/50	Grundfos 15/50	Grundfos 15/50	Grundfos 15/60	Grundfos 15/60			
Boiler Pump	Grundfos 15/50	Grundfos 15/50	Grundfos 15/50	Grundfos 15/60	Grundfos 15/60			
Primary/heating pipe connections	22mm	22mm	22mm	28mm	28mm			
MCW & DHW pipe connections	22mm	22mm	22mm	22mm	22mm			
Cold feed/expansion connection	15mm	15mm	15mm	15mm	15mm			
Safety open vent connection	22mm	22mm	22mm	22mm	22mm			
Primary connections (for summer use bathroom towel rail)	15mm	15mm	15mm	15mm	15mm			
Drain Connection	R ½"	R ½"	R ½"	R ½"	R ½"			
Maximum Head Thermal Store	10 meters	10 meters	10 meters	10 meters	10 meters			
Maximum pressure heating circuit	3 bar	3 bar	3 bar	3 bar	3 bar			
Maximum pressure domestic water	5 bar	5 bar	5 bar	5 bar	5 bar			
Volume of primary coil (litres)	2.0	2.0	2.0	4.0	4.0			
Hot water flow rate	up to 35 lts/min	up to 35 lts/min	up to 35 lts/min	up to 35 lts/min	up to 35 lts/min			
Max boiler size	15 kW	20 kW	25 kW	30 kW	35 kW			
'Switch'	9kW	9kW	9kW	9kW	9kW			
<b>Typical Dwelling types</b>								
Bedrooms	1-3	2-3	2-4	3-5	4-6			
Bathrooms	1	1	2	1	2	2	3	4
En-suite shower	1	2	1	4	2	4	2	0

### Notes:-

- The SysteMate 225 appliance is suitable for use in large properties because it produces the same 'peak hour output' as a typical 250 - 320 litre unvented cylinder. For properties requiring the SM 225 the incoming main should be a minimum of 32mm MDPE with a pressure of not less than 2 bar dynamic and an adequate flow in line with the pipe sizing calculations. In many cases, properties of this size will benefit from having 2 smaller sized appliances located adjacent to the areas of peak hot water use which will increase the available flow rate and may remove the need to provide trace heating on the hot water distribution.
- The plastic F & E cistern complete with fittings and the expansion vessel are supplied separately.
- The flow rates are based on a 35°C temperature rise and assume normal pressure and adequate flow to the appliance. The actual flow rate from the appliance is automatically regulated to a maximum of 28 litres/min.
- Models are available in Hard and Soft water versions (suffixed 'H' or 'S').
- Unit is supplied on a 100mm high installation base.
- The domestic hot water outlet temperature is automatically regulated to approximately 55°C at the bath flow rate of 18 litres/min recommended by BS 6700. The temperature is not user adjustable.
- The maximum boiler size shown above is for the standard pump fitted and for a typical system. The designer/installer must calculate the suitability of the standard pump as part of normal design procedures.
- The expansion vessel sizes shown above have been calculated to be adequate for typical systems. The designer/installer must calculate their suitability for the actual system and provide an extra vessel if required.

# 1.0 DESIGN

## 1.2 TECHNICAL DATA

### Standard Equipment

The standard configuration of the SystemeMate 2000 is shown opposite. The Appliance Control Board (A.C.B.), mounted inside the appliance, controls the operation of the complete system. The A.C.B. is pre-wired to a terminal strip where all electrical connections terminate. It is supplied with the following factory fitted equipment:-

1. Space heating pump
2. Domestic hot water primary (plate heat exchanger) pump
3. Boiler pump
4. Hard water appliance control board (A.C.B)
5. Electro-mechanical clock to control the space heating (in conjunction with room thermostat - if fitted)
6. Expansion vessel for the primary/heating system (supplied separately)
7. Plate heat exchanger
8. DHW temperature sensor
9. PHE return sensor
10. Store temperature sensor
11. Y type strainer/flow regulator
12. A feed and expansion cistern for filling the primary thermal store (complete with cold feed/open vent pipework assembly) is supplied separately.

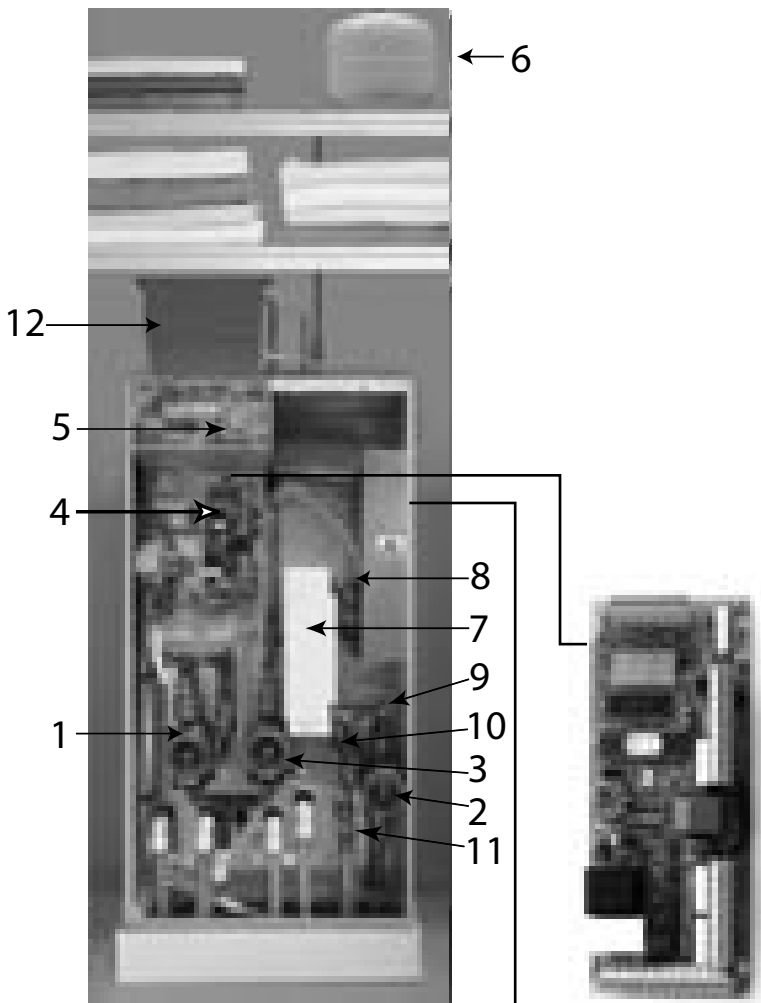

Appliance Control Board  
A.C.B.



Electro-mechanical clock  
programmer



Digital clock programmer

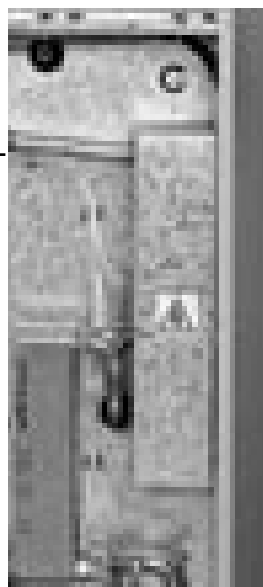

Switch

### Optional Extra Equipment

- \* A soft water model is available for areas where the hardness level is below 200 p.p.m. (mg/ltr)
- \* Flexible connection kit for use in connection with suitable push fit connectors for quick connection to first fix pipe installation.
- \* 'Switch' emergency electrical back-up for hot water and/or heating in the event of a boiler fault.
- \* A seven day digital clock/programmer to control the space heating (in conjunction with a room thermostat if fitted).
- \* A kit to site the clock/programmer remotely.
- \* A no clock option - because of the design of the appliance it should not be necessary to fit anything other than a single channel clock to control the heating system.
- \* 15mm 3 bar pressure relief (safety) valve for fitting near the boiler (see boiler manufacturers recommendations).
- \* Pressure gauge and filling loop for fitting near the boiler.
- \* Hot and cold water manifolds for use with plastic pipework.
- \* Ballvalve/overflow connector for F & E cistern.

# 1.0 DESIGN

## 1.2 TECHNICAL DATA

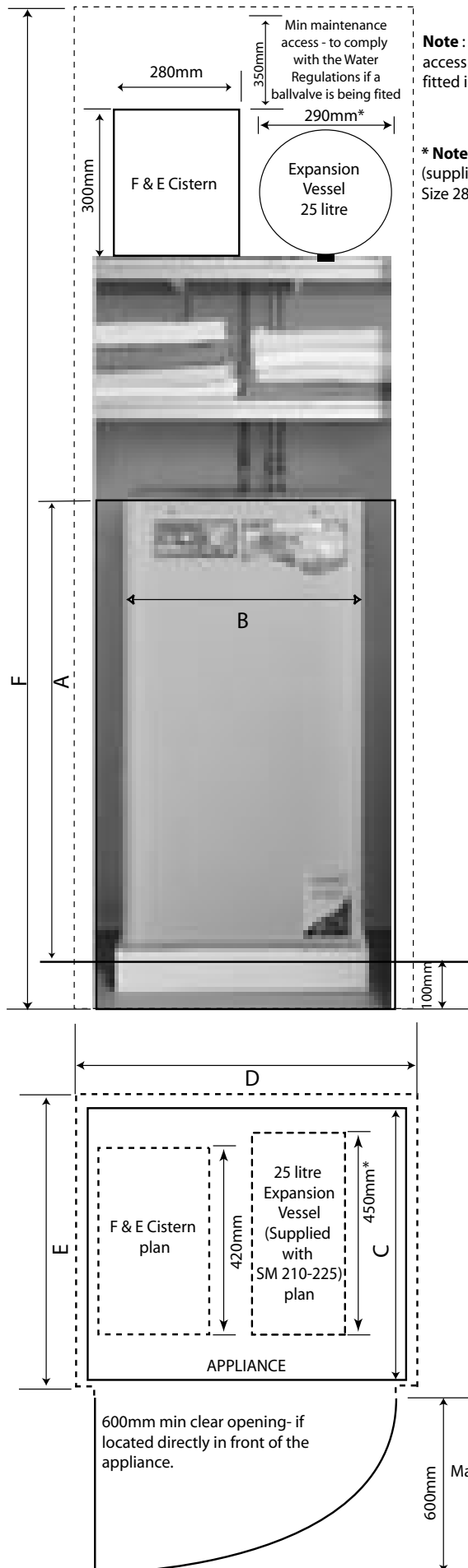

**Note :** 225mm is considered adequate access if the ballvalve is not being fitted i.e. manual fill is being used

**\* Note :** 12 litre vessel (supplied with SM 125 - 185)  
Size 280mm diam x 300mm long

**Note:** The dimensions below do not allow for the 100mm high installation base.

APPLIANCE DIMENSIONS			
Model	Height	Width	Depth
	A	B	C
SM 125	1140mm	595mm	595mm
SM 145	1140mm	595mm	595mm
SM 185	1350mm	595mm	595mm
SM 210	1495mm	595mm	595mm
SM 225	1670mm	595mm	595mm

The following table of minimum cupboard dimensions only allow the minimum space required for the appliance (including the F & E cistern and expansion vessel) and any extra space required for shelving etc in the case of airing cupboards etc must be added.

MINIMUM CUPBOARD DIMENSIONS			
Model	Height	Width	Depth
	F	D	E
SM 125	1890mm	700mm	600mm
SM 145	1890mm	700mm	600mm
SM 185	2100mm	700mm	600mm
SM 210	2245mm	700mm	600mm
SM 225	2420mm	700mm	600mm

**Note:** The above dimensions are based on the Appliance and the F & E cistern (fitted with a ballvalve) being in the same cupboard. If the manual fill method is chosen the heights can be reduced by 125mm.

# 1.0 DESIGN

## 1.2 TECHNICAL DATA

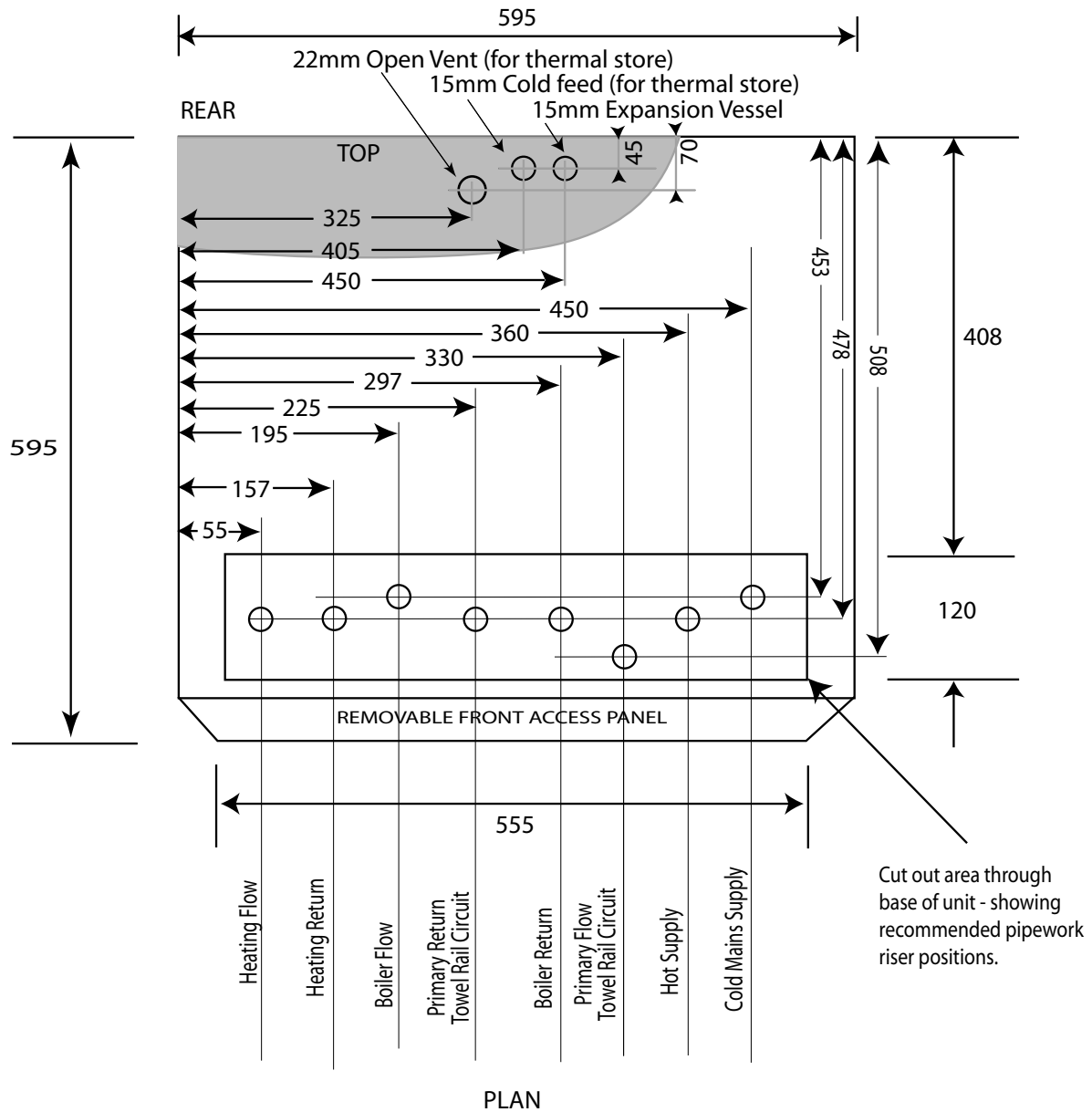

The SystemeMate 2000 units are supplied on an installation base to allow the pipe runs to connect to the appliance from any direction. It is easier if all pipes protrude vertically in the cut out area shown. Compression or push fit connections can be used and we do offer a set of flexible connectors as an option, (for use with suitable push fit connectors only). All pipe positions are approximate and subject to a tolerance of +/- 10mm in any direction. Space for a 15mm cold water supply and a 22mm warning/overflow pipe for the separate feed and expansion cistern (if fitted) will also be required.

If a warning/overflow pipe is NOT provided the F & E cistern should be filled from a temporary hose connection incorporating a double check valve. This can be from a temporary hose connection supplied from any cold water tap or from a permanent cold branch provided adjacent to the F & E cistern. The temporary connection must be removed once the appliance is filled.

\* Drawing not to scale.



# 1.0 DESIGN

## 1.2 TECHNICAL DATA

Note: 1mW.G. = 10kPa

Heating/cooling exchange (small pressure loss of 1.5mW.G. @ 0.5 l/s)

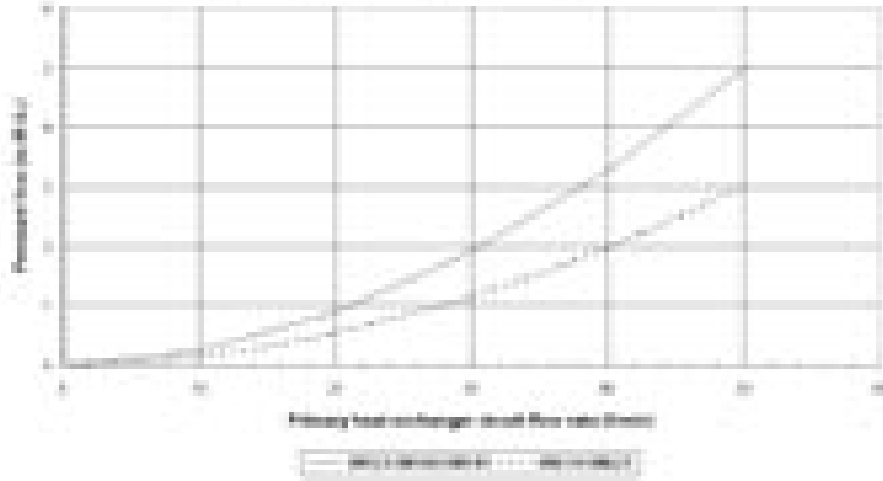

Heating/cooling exchange (small pressure loss of 1.5mW.G. @ 0.5 l/s)

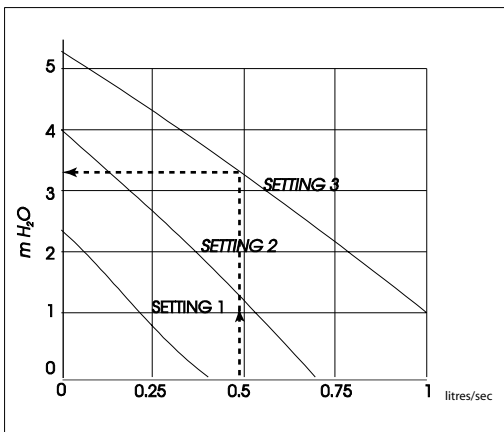
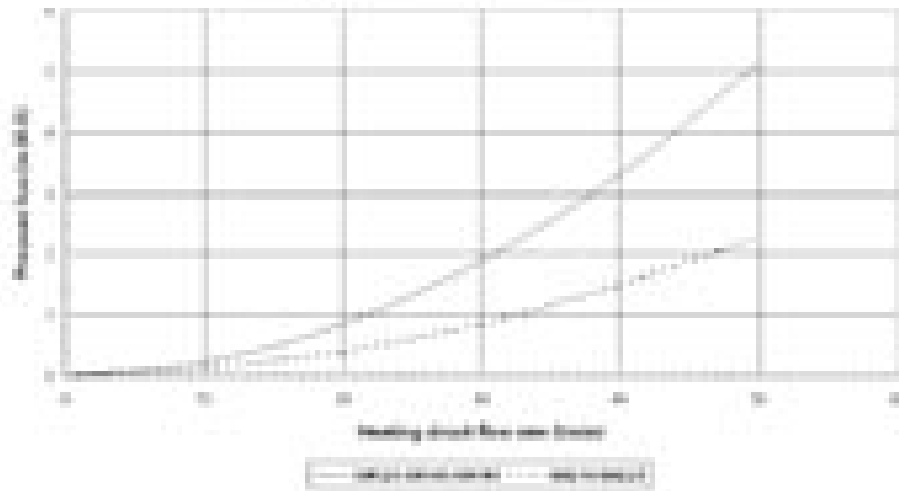

**GRUNDFOS 15/50**

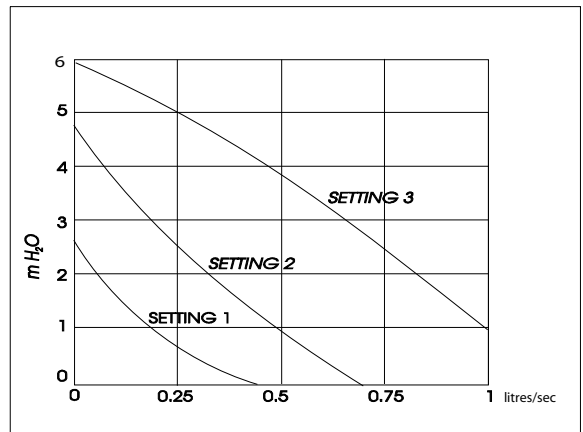

**GRUNDFOS 15/60**

**PERFORMANCE GRAPHS OF GRUNDFOS PUMPS**

# 1.0 DESIGN

## 1.3 SYSTEM DETAILS

### Hot and Cold Water System

#### General

A schematic layout of the hot and cold water services in a typical small dwelling is shown below. Systemate 2000 will operate at mains pressures as low as 1 bar and as high as 5 bar although the recommended range is 2-3 bar. If the manifolds (available as an optional extra) are being used the inlet pressure to the manifold must be a minimum of 2 bar. It is also important to check that all other equipment and components in the hot and cold water system are capable of accepting the mains pressure available to the property. If the mains pressure can rise above 5 bar or the maximum working pressure of any item of equipment or component to be fitted in the system, a suitable pressure limiting (reducing) valve will be required.

**Note:** Each Systemate 2000 is fitted with a strainer and flow regulator on the cold mains supply connection. If the supply pressure is less than 2 bar or if the manifolds (available as an optional extra) are being used or if all taps are provided with flow regulators the flow regulator on the cold inlet should be removed.

No check valve or similar device should be fitted on the cold water supply branch to the Systemate 2000.

Because of the innovative method of hot water production no scale reducer is required on the branch to the appliance. However, to comply with the Benchmark Guidance Note for Water Treatment in Heating and Hot Water Systems the installer should check the hardness level of the water supply and if necessary fit a scale reducer to provide protection to the whole of the domestic water system.

The hot water flow rate from the Systemate 2000 is directly related to the adequacy of the cold water supply to the dwelling. This must be capable of providing for those services, which could be required to be supplied simultaneously, and this maximum demand should be calculated using procedures defined in BS 6700.

If a water meter is fitted in the service pipe, it should have a nominal rating to match the maximum hot and cold water peak demands calculated in accordance with BS 6700. This could be up to 80ltr/min in some properties.

**Note:** The diagram below shows the F & E cistern with a ballvalve and warning/overflow pipe which can be fitted if required. However, the standard preferred arrangement is for the cistern to be manually filled from a temporary hose connection fitted with a double check valve.

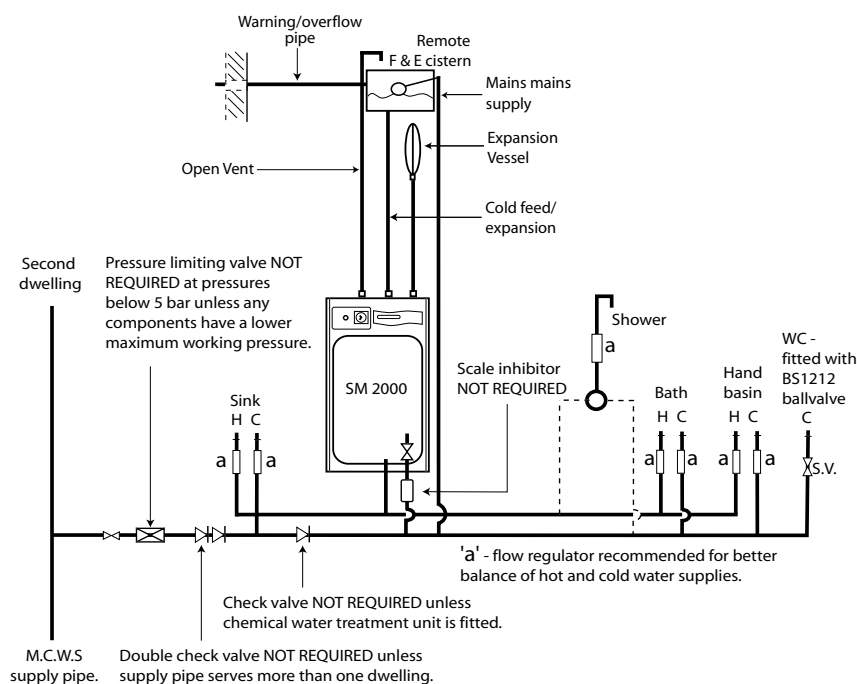

**Typical hot and cold water distribution**

## 1.3 SYSTEM DETAILS

### Hot and Cold Water System

#### Pipe Sizing / Materials

To achieve even distribution of the available supply of hot and cold water, it is important in any mains pressure system, that the piping in a dwelling should be sized in accordance with BS 6700. This is particularly important in a large property with more than one bathroom.

However, the following rule of thumb guide lines should be adequate for most smaller property types as long as water pressures are within the recommended range of 2-3 bar.

1. A 15mm copper or equivalent external service may be sufficient for a small 1bathroom dwelling (depending upon the flow rate available), but the minimum recommended size for new dwellings is 22mm (25mm MDPE).
2. The internal cold feed from the main incoming stop tap to the SystemeMate should be run in 22mm pipe. The cold main and hot draw-off should also be run in 22mm as far as the branch to the bath tap.
3. The final branches to the hand basins and sinks should be in 10mm and to the baths and showers in 15mm. (1 metre recommended)
4. **We would recommend that best results for a balanced system are achieved by fitting appropriate flow regulators to each hot and cold outlet. These MUST be fitted in cases where the final branch pipe sizes are not as recommended in item 3 or water pressures are above the recommended water pressure range of 2-3 bar. See Appendix A for further details.**

**Note: If manifolds (available as an optional extra) are being used suitable flow regulators are automatically provided in the manifold and do not need to be provided at each outlet - See Appendix B for further details.**

**Note: If a warning/overflow pipe is NOT provided the F & E cistern should be filled from a temporary hose connection supplied from any cold water tap or from a permanent cold branch provided adjacent to the F & E cistern. The temporary hose must be fitted with a double check valve and removed once the appliance is filled.**

All the recommendations with regard to pipework systems in this manual are generally based on the use of BS/EN Standard copper pipework and fittings.

However, we are happy that plastic pipework systems can be used in place of copper internally as long as the chosen system is recommended for use on domestic hot and cold water systems by the manufacturer and is installed fully in accordance with their recommendations.

This is particularly important in relation to use of push fit connections when using the optional flexible hose kits - see 2.2 Installation, Pipework connections.

It is also essential that if an alternative pipework material/system is chosen the manufacturer confirms that the design criteria of the new system is at least equivalent to the use of BS/EN Standard copper pipework and fittings.

#### Taps/Shower Fittings

Aerated taps are recommended to prevent splashing.

Any type of shower mixing valve can be used as long as both the hot and cold supplies are mains fed. However, all mains pressure systems are subject to dynamic changes particularly when other hot and cold taps/showers are opened and closed. To minimise the impact of this we would always recommend the use of thermostatic showers with this appliance.

The shower head provided must also be suitable for mains pressure supplies.

The hot water supply to a shower-mixing valve should be fed wherever practical directly from the SystemeMate 2000 or be the first draw-off point on the hot circuit. The cold supply to a shower-mixing valve should wherever practical be fed directly from the rising mains via an independent branch. The shower must incorporate or be fitted with the necessary check valves to provide back-syphonage protection in accordance with the Water Regulations.

The supply of hot and cold mains water directly to a bidet is permitted provided that it is of the over-rim flushing type and that a type 'A' air gap is incorporated.

#### Hot and Cold Water System.

If the length of the hot water draw off pipework is excessive and the delivery time will be more than 60 seconds before hot water is available at the tap, you may wish to consider using trace heating to the hot water pipework such as the Raychem HWAT system.

The appliance has not been designed to suit a re-circulating domestic hot water circuit.

Please consult Gledhill Technical Department for further details.

It is important that the cold water pipework is adequately separated/protected from any heating/hot water pipework to ensure that the water remains cold and of drinking water quality.

# 1.0 DESIGN

## 1.3 SYSTEM DETAILS

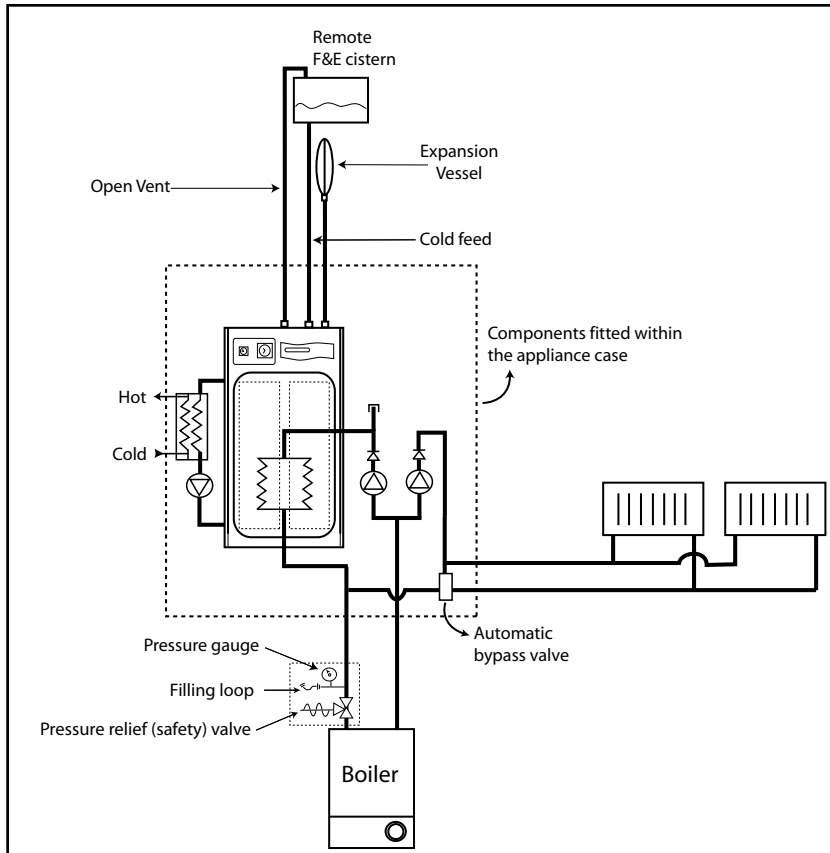

### Heating System

#### General

A schematic layout of the heating system in a typical small dwelling is shown above.

The flow and return from the boiler must always run directly to the SysteMate 2000 and the flow should rise continuously to facilitate venting. The heating circuit is taken from the SysteMate 2000 and is piped in the conventional manner.

The SysteMate 2000 is only suitable for a sealed heating system and therefore boiler/heating pipework can run at a higher level than the store.

It is recommended that the F & E cistern for the appliance is fitted at high level in the same cupboard as the SysteMate 2000. However, it can be fitted remotely up to 10m above the base of the SysteMate 2000 i.e. the maximum static pressure in the store must not exceed 1 bar.

It is recommended that the expansion vessel is fitted at high level in the appliance cupboard alongside the F & E cistern.

The performance of the system pump and the pressure losses through the SysteMate 2000 primary coil circuit are shown in 1.2 Technical Data. The nett pump head available for the heating circuit can be determined from these figures and this nett pump head should be used for sizing the heating circuit pipework.

**For example:** At 24 litres/min primary flow rate, the pressure loss through the SysteMate 2000 model SM210 (coil and fittings) is 2.1m W.G. (21kPa). The maximum pump head available at 24 litres/min and setting 3 is 3.2m H<sub>2</sub>O (32kPa), therefore 1.1m W.G. (11kPa) is available for the boiler circuit.

With sealed heating systems air is released during the first few weeks of operation. This will need to be vented and the system re-pressurised.

The overflow/warning pipe should be installed in a material suitable for a heating system feed and expansion cistern in accordance with BS 5449.

An automatic bypass is fitted on the SysteMate 2000 to compensate for pressure (i.e. flow) rate changes in the heating circuit e.g. when the thermostatic radiator valves close. The system does not require any other bypass valves but a bypass radiator used in conjunction with a room thermostat is suitable.

There shall be no permanent connection to the mains water supply for filling the system, even through a non-return valve without the approval of the Local Water Authority. An approved filling loop is required with the SysteMate 2000 (available as an optional extra) which this should be disconnected after commissioning the system. This should be located adjacent to the boiler along with a suitable gauge and pressure relief valve (also available as optional extras) as shown opposite.

## 1.3 SYSTEM DETAILS

### Heating System

#### Pipe Sizing/Materials

The SystemeMate 2000 is designed to be installed with any condensing or non condensing boiler which is suitable for a sealed heating system (i.e. fitted with an overheat thermostat) and is capable of delivering hot water at a minimum of 80°C.

The primary pipework connecting the boiler and the thermal store should be sized to achieve a maximum of 11°C rise across the boiler or the maximum temperature rise specified by the boiler manufacturer, whichever is smaller, but in any instance it should not be less than 22mm copper tube.

If the boiler is a condensing type the boiler must be set to operate at a normal 82°C flow 71°C return system.

**Note:** There should be no valves in the pipework connecting the boiler to the SystemeMate 2000.

The heating circuit operates on the normal primary boiler temperatures i.e. 82°C flow and 71°C return. Therefore any traditional hot water radiators or convectors can be used with this system and no special over-sizing of the heat emitters is necessary.

All the recommendations with regard to pipework systems in this manual are generally based on the use of BS/EN Standard copper pipework and fittings.

However, we are happy that plastic pipework systems can be used in place of copper internally as long as the chosen system is recommended for use on domestic heating systems by the manufacturer and is installed fully in accordance with their recommendations. We always recommend the use of barrier pipe for these systems.

It is also essential that if an alternative pipework material/system is chosen the manufacturer confirms that the design criteria of the new system is at least equivalent to the use of BS/EN Standard copper pipework and fittings.

#### Boiler Size

It is only necessary to calculate the heating requirements in accordance with BS 5449. The allowances shown below should be added for domestic hot water. The control system automatically gives priority to hot water when necessary.

Allowance for Domestic Hot Water	
Model	(kW)
SM125	2
SM145	3
SM185	3
SM210	3.5
SM225	4

#### Boiler Sited Below SystemeMate 2000

The flow pipe from the boiler to the SystemeMate 2000 must rise continuously. No valve shall be fitted in the primary flow pipe as this forms the expansion pipe to the expansion vessel.

The size of the primary pipework connecting the boiler to the SystemeMate 2000 must not be less than 22mm (or that specified by the boiler manufacturer).

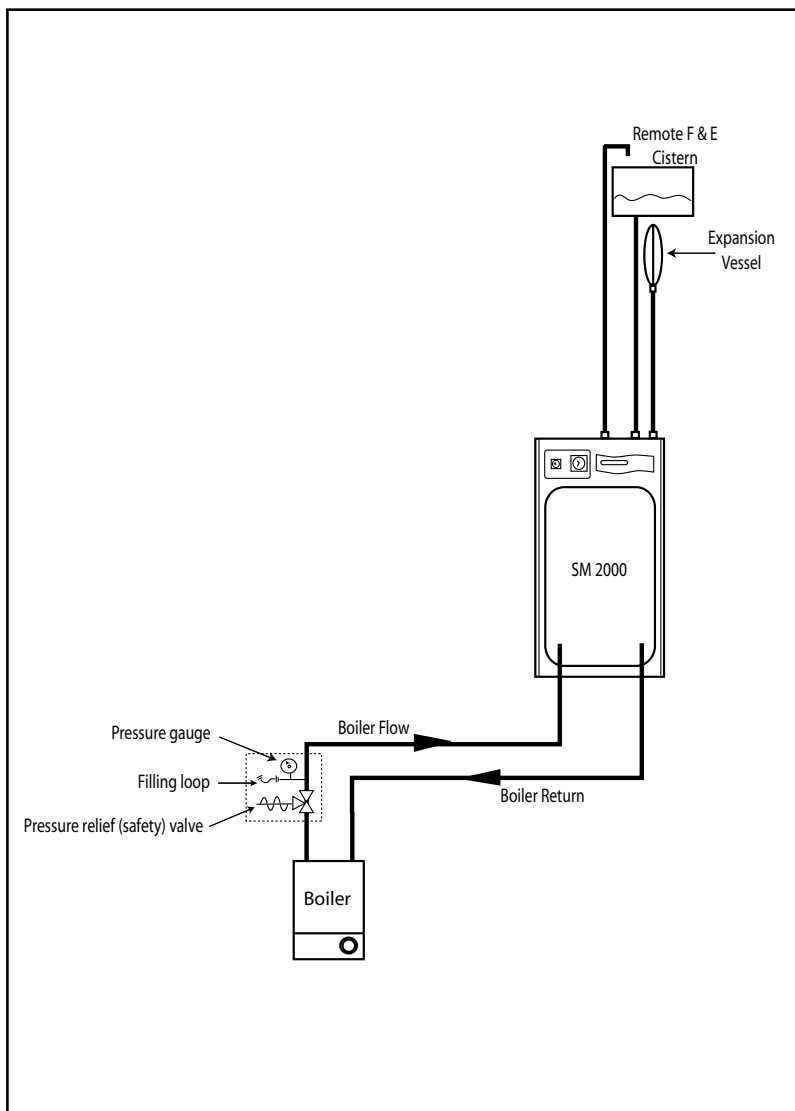

# 1.0 DESIGN

## 1.3 SYSTEM DETAILS

### Heating System

#### Boiler sited above the Systemate or with dipped flow and return pipes

A gravity check valve should be fitted in the boiler return pipework to prevent gravity circulation between the Systemate 2000 and the boiler during dormant periods.

An automatic air vent will be required on the flow adjacent to the boiler and depending upon the pipe layout an automatic or manual air vent will also be required on the return adjacent to the boiler.

The pressure relief (safety valve) must be located on the flow immediately adjacent to the boiler.

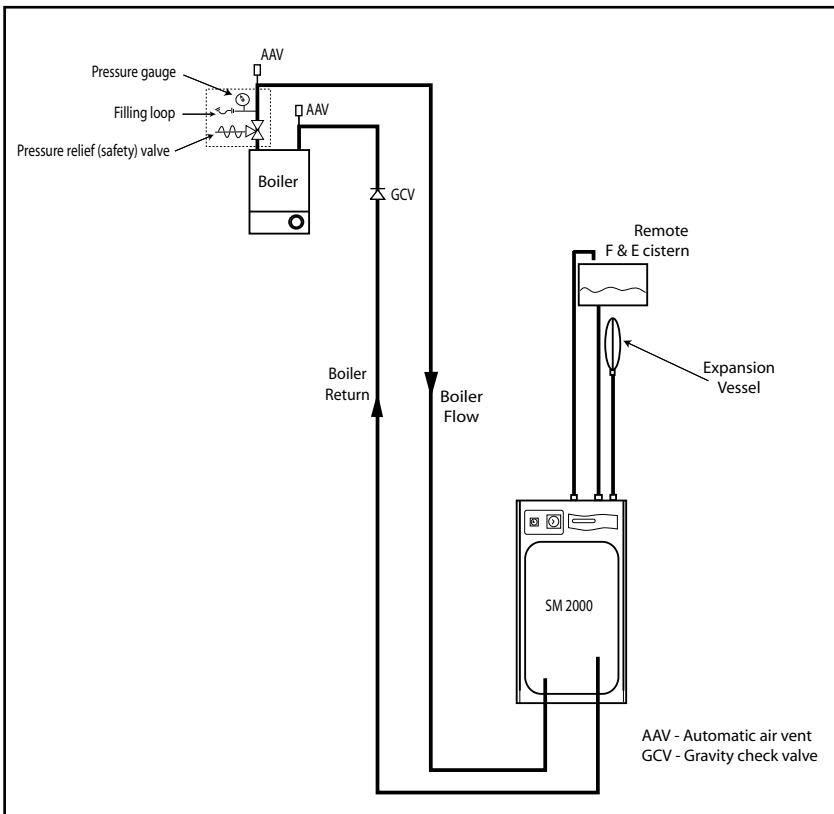

### Heating System

#### Connection of Bathroom Radiator/Towel Rail for Summer use

If a pumped circuit is required for a bathroom radiator/towel rail, the flow and return pipework can be connected into the 15mm copper blanked connections provided. We recommend any radiators/towel rails on this circuit are provided with T.R.V.'s and that the total heat output of the radiators/towel rails is not more than 5% of the boiler output.

**The radiators will only get hot when the boiler is firing and the store is being heated.**

It is important that the flow rates through these radiators is adjusted to the minimum required at the lockshield valves on the radiators. If this is not done the performance of the Systemate will be adversely affected.

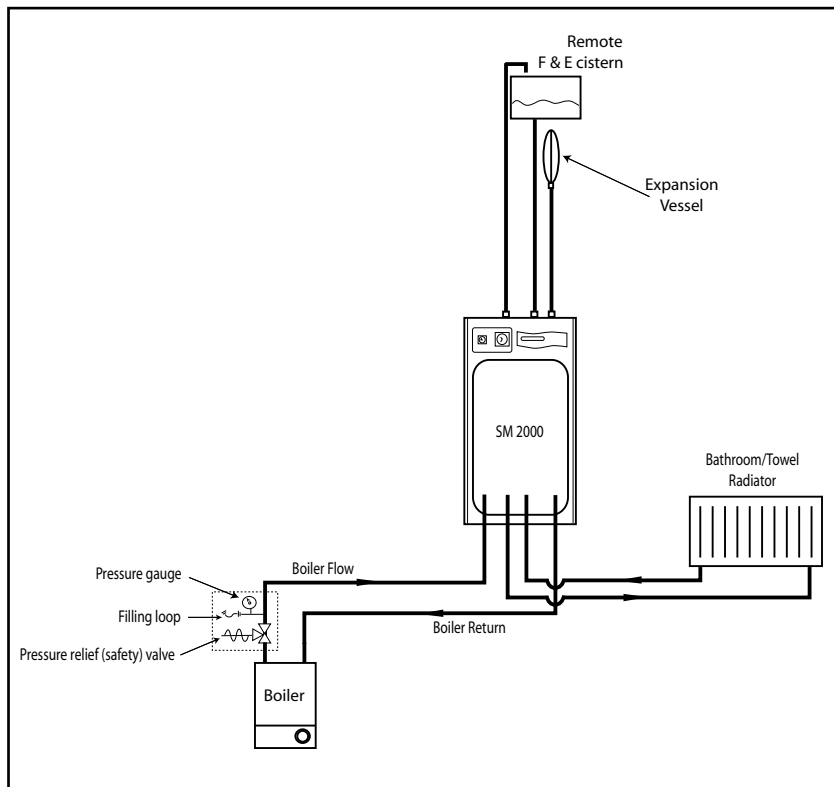

## 1.3 SYSTEM DETAILS

### Heating System

#### Expansion Vessel Requirements

The Systemate expansion vessel is pre-charged to 1.0 bar. The maximum water content of the heating system (boiler + radiators + connecting pipework + primary coil but NOT store volume) must not be greater than those shown in the table below.

A figure of 4.5 litres/kW of installed radiator capacity can be used for a preliminary assessment of the water content of the heating system.

The values presented in the table are based on a maximum boiler flow temperature of 93°C. The expansion vessel must be suitable to accommodate the change in volume of the water in the system when heated from 10°C to 110°C as specified in BS 5449: 1990 clause 16.2.

The primary heating coil and pipework volumes are shown in the table in 1.2 Technical Data.

In normal circumstances an initial vessel and system charge pressure of 1 bar is suitable for most domestic purposes.

The minimum system pressure should not be less than the static head plus 0.5 bar i.e. the height of the highest point in the system above the expansion vessel plus a margin of 0.5 bar.

If the system volume is greater than that shown in the table at the selected operating conditions then an additional expansion vessel must be fitted.

### 'Switch'

The Systemate 2000 can be ordered with the option of 'Switch' which provides a 9kW electrical emergency back up in the case of failure of the main heat source i.e. gas boiler.

**This must NOT be used to provide hot water only in summer if the main system is working correctly.**

If Switch is ordered the electrical supply will need to take account of the increased load. Full details of the requirements are provided in Section 2.1 Site Requirements and 2.2 Installation.

Otherwise the design requirements are the same as the standard appliance.

Switch can operate on 'hot water' or 'hot water and heating' modes. In the former only hot water pump and electric heating element are energized. In the latter the heating system pump is also energized. This means that the heating will be on permanently unless manually switched back to the 'hot water' only position.

It also means that wherever Switch is being used the normal domestic hot water temperature controls are over-ridden. Initially dependent on the flow rate/store temperature hot water can be delivered at the tap at temperatures as high as 75°C. A warning notice to this effect is provided in the front of the appliance.

However, once the initial store temperature has been reduced the Switch element thermostat will reduce the temperature at the tap to no more than 65°C. Full details of how to operate the system are provided on a label fixed to the front of the appliance.

12 Litre Vessel i.e. SM 125/145/185								
Maximum Recommended Heating System Volumes								
Safety valve setting (bar)	3.0							
Vessel charge pressure (bar)	0.5			1.0			1.5	
Initial system pressure (bar)	0.5	1.0	1.5	1.0	1.5	2.0	1.5	2.0
Maximum permitted system volume (litres)	140	80	40	110	60	27	70	35

25 Litre Vessel i.e. SM 210/225								
Maximum Recommended Heating System Volumes								
Safety valve setting (bar)	3.0							
Vessel charge pressure (bar)	0.5			1.0			1.5	
Initial system pressure (bar)	0.5	1.0	1.5	1.0	1.5	2.0	1.5	2.0
Maximum permitted system volume (litres)	270	160	85	200	115	50	140	65



# 2.0 INSTALLATION

## 2.1 SITE REQUIREMENTS

The appliance is designed to be installed in an airing/cylinder cupboard and the relevant minimum dimensions are provided in section 1.2 Technical Data.

Because of the ease of installation we recommend that the cupboard construction is completed and painted before installation of the appliance. The cupboard door can be fitted after installation.

If the unit needs to be stored prior to installation it should be stored upright in a dry environment and on a level base/floor.

Installation and maintenance access is needed to the front of the appliance and above the F & E cistern. See Technical Data section for further details.

The minimum dimensions contained in section 1.2 Technical Data allow for the passage/connection of pipes to the appliance from any direction as long as the appliance is installed on the installation base provided. If the installation base is not used extra space may be needed to allow connection to the pipework and the whole of the base area should be continuously supported on a material which will not easily deteriorate if exposed to moisture.

The floor of the cupboard needs to be level and even and capable of supporting the weight of the appliance when full. Details of the weight when full is provided in section 1.2 Technical Data.

The appliance is designed to operate as quietly as practicable. However, some noise (from pumps etc) is inevitable in any heating system. This will be most noticeable in cupboards formed on bulkheads, or at the mid span of a suspended floor. In these cases the situation can be improved by placing the appliance on a suitable sound deadening material (i.e. carpet underlay or similar).

Cupboard temperatures will normally be higher than in a conventional system and the design of the cupboard and door will need to take this into account. No ventilation is normally required to the cupboard.

A suitable location will be needed for the separate feed and expansion cistern and expansion vessel. This will often be at high level in the cupboard housing the Systemate 2000. The dimensions and clearances are provided in section 1.2 Technical Data. The location will need to provide a suitable route for the cold feed/expansion pipe and the open safety vent pipe for the appliance as well as the connecting pipe to the system expansion vessel. The location will also need to provide a suitable route and discharge position for the warning/overflow pipe and the ballvalve supply from the mains cold water system if these are being fitted.

**Note: The standard appliance is supplied with a cistern without a ballvalve/overflow for filling manually.**

An electrical supply must be available which is correctly earthed, polarized and in accordance with the latest edition of the IEE requirements for electrical Installations BS 7671.

The electrical mains supply needs to be 230V/50Hz/1Ph

Connection must be made using a double-pole linked isolator with a contact separation of 3mm in both poles which is located within 1m of the appliance. The supply must only serve the appliance.

The supply to the standard appliance shall be fused at 3 amp - nominal maximum full load current for all SM models = 1.4 amps (this does not include the boiler).

If the 'Switch' electrical emergency backup is being provided, the minimum breaking capacity of the main isolation switch and cable sizes/lengths at 230V shall follow the recommendations in the table below.

Nominal full load current	Min rating of isolating switch	Cable size	Max. recommended cable run-based on 9.2V drop and 0.4 second disconnection time using a type 1 or B breaker
41.0 Amps	45 Amps	10 mm <sup>2</sup>	49 metres
Recommended circuit protection device - based on 0.4 second disconnection time		45A type 1 - M.C.B. to BS 3871 45A type B circuit breaker to BS EN 60898	

### Electrical Supply requirements for Systemate<sup>2000</sup> with Switch



## 2.2 INSTALLATION

### Preparation/placing the appliance in position.

Details of the recommended positions for termination of the first fix pipework are provided in section 1.2 Technical Data. The pipework can be located or its position checked using the template provided with each appliance. If these have been followed installation is very simple and much quicker than any other system. The appliance is supplied shrink wrapped on a timber installation base. Carrying handles are also provided in the back of the casing.

The feed and expansion cistern complete with ballvalve, cold feed/expansion and overflow/warning fittings are provided in a separate box along with the system expansion vessel. If flexible connections have been ordered these will also be inside the feed and expansion cistern.

The appliance should be handled carefully to avoid damage and the recommended method is shown opposite. Before installation the site requirements should be checked and confirmed as acceptable. The plastic cover and protective wrapping should be removed from the appliance and the installation base (provided) placed in position.

The appliance can then be lifted into position in the cupboard on top of the base and the front panel removed by unscrewing the 2 screws and lifting the door up and out (see opposite) ready for connection of the pipework and electrical supplies. The feed and expansion cistern support shall be installed ensuring that the base is fully supported and the working head of the appliance is not exceeded. The recommended access for maintenance must also be provided - see section 1.2 Technical Data.

**Note:** Although the above guidance is provided any manual handling/lifting operations will need to comply with the requirements of the Manual Handling Operations Regulations issued by the H.S.E.

The appliance can be moved using a sack truck on the rear face although care should be taken and the route should be even.

In apartment buildings containing a number of storeys we would recommend that the appliances are moved vertically in a mechanical lift.

If it is proposed to use a crane expert advice should be obtained regarding the need for slings, lifting beams etc.

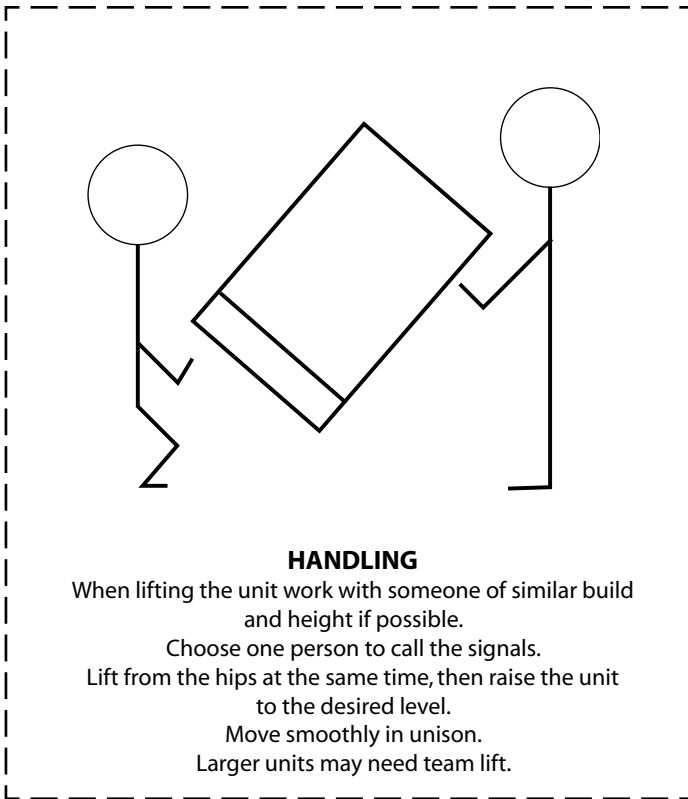

### HANDLING

When lifting the unit work with someone of similar build and height if possible.  
Choose one person to call the signals.  
Lift from the hips at the same time, then raise the unit to the desired level.  
Move smoothly in unison.  
Larger units may need team lift.



## 2.0 INSTALLATION

### 2.2 INSTALLATION

#### Pipework connections

The position of the pipework connections is shown opposite. The connection sizes and dimensions are listed in Section 1.2 Technical Data.

All the connections are also labelled on the appliance. It is essential that the pipework is connected to the correct connection.

The connections can be hard piped but we recommend the use of flexible connections (available as an optional extra).

When using push fit connectors with the flexible hose kits it is important to check that they are compatible. Written approval has already been obtained for:-

Hepworth - Hep<sub>2</sub>O BiTite

John Guest - Speedfit

Yorkshire - Tectite

However, as similar assurances cannot be obtained for Polypipe fittings we cannot recommend their use.

Connections A, B, D, E, F, G, H, I, and L are plain ended copper pipe.

Connections C & J are compression fittings.

Connection K is a RC $\frac{1}{2}$  ( $\frac{1}{2}$ " BSPT internal)

- A - Safety open vent
- B - Cold feed/expansion
- C - Expansion vessel pipe
- D - Central heating flow
- E - Central heating return
- F - Primary flow (from boiler)
- G - Primary return (for summer use bathroom towel rail circuit)
- H - Primary return (to boiler)
- I - Domestic hot water
- J - Incoming mains water
- K - Drain (valve is not provided with the appliance)
- L - Primary flow (for summer use bathroom towel rail circuit)

**Note:** The safety open vent and cold feed/expansion should be connected to the F & E cistern using the pipework assembly provided.

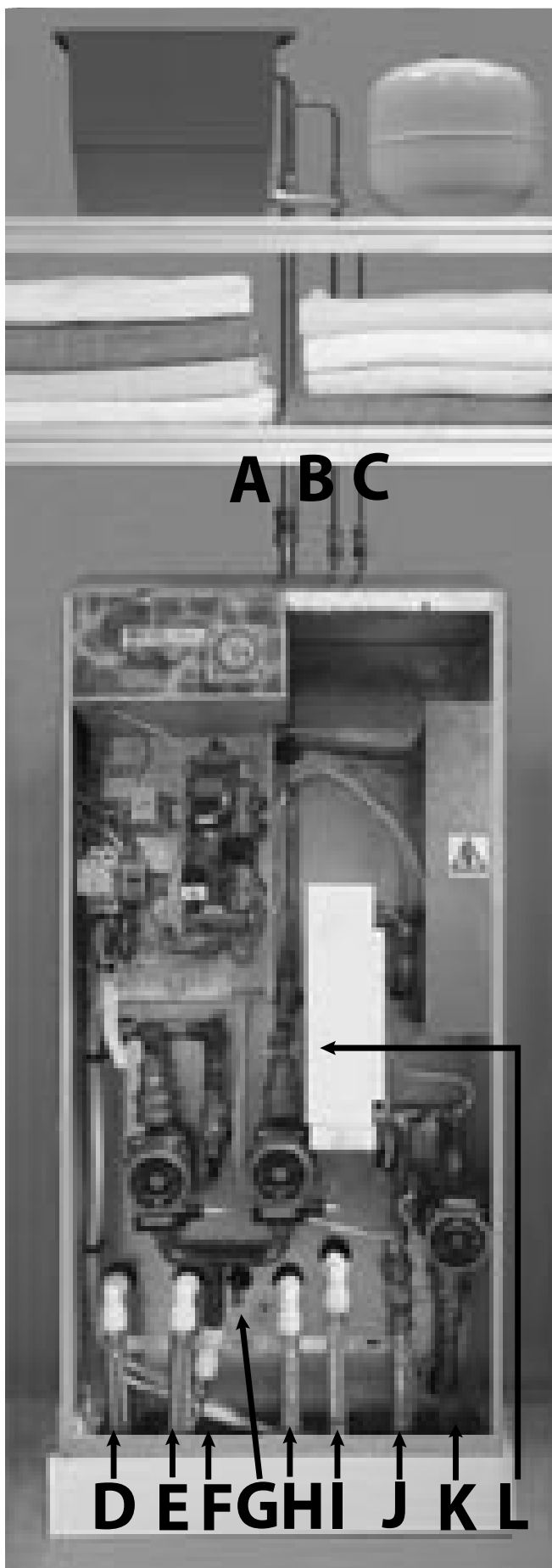

## 2.2 INSTALLATION

All factory made joints should be checked after installation in case they have been loosened during transit.

The fittings for the feed and expansion cistern should be installed following the instructions provided by the manufacturer in a position to suit the particular location and the cistern fitted on its supports/base.

The cold feed/expansion and safety open vent should be installed between the appliance and the feed and expansion cistern.

**Combined feed and open vent pipe arrangements must not be used.**

No valves should be fitted in the safety open vent which must be a minimum of 22mm copper pipe or equivalent.

The expansion vessel should be positioned on the supports provided and the connecting pipe from the Systemate 2000 connected to the air vent assembly provided.

If an overflow/warning pipe is fitted it shall have a continuous fall, be fitted to discharge clear of the building and be sited so that any overflow can be easily observed. It shall also be installed in a size and material suitable for use with heating feed and expansion cisterns in accordance with BS 5449 and should not have any other connections to it.

It is normally envisaged that the feed and expansion cistern will be located in the same cupboard as the Systemate appliance itself to maintain a dry roof space.

The cold feed/open vent pipework assembly (as supplied) should be used if it is intended to install the F & E cistern directly on top of the appliance.

However, if it is necessary to locate the cistern in the roof space (or on a higher floor) the cold feed/open vent pipework assembly (as supplied) should be used to connect to the F & E cistern and pipework site run by the installer to connect this to the appliance,

Obviously, any pipework in the roof space and the feed and expansion cistern will need to be adequately insulated to protect against frost damage.

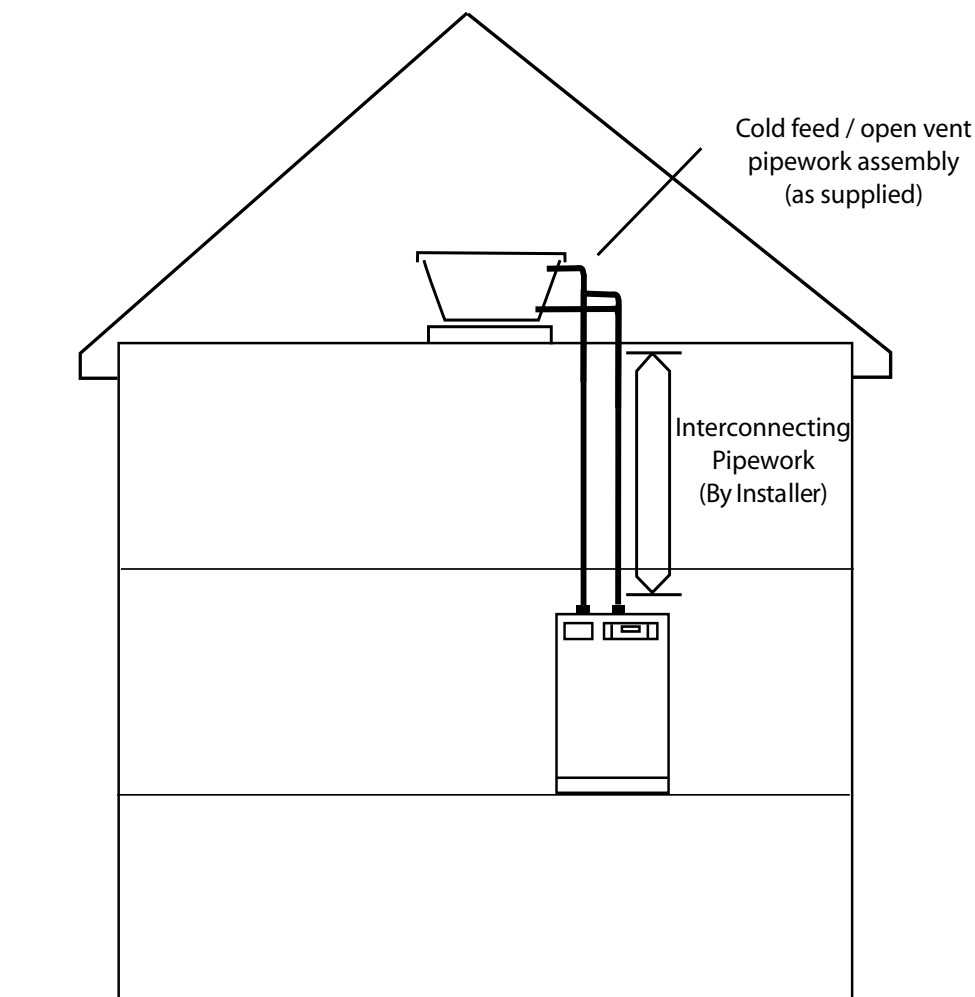

# 2.0 INSTALLATION

## 2.2 INSTALLATION

### WIRING DIAGRAM - STANDARD SYSTEMATE<sup>2000</sup> APPLIANCE

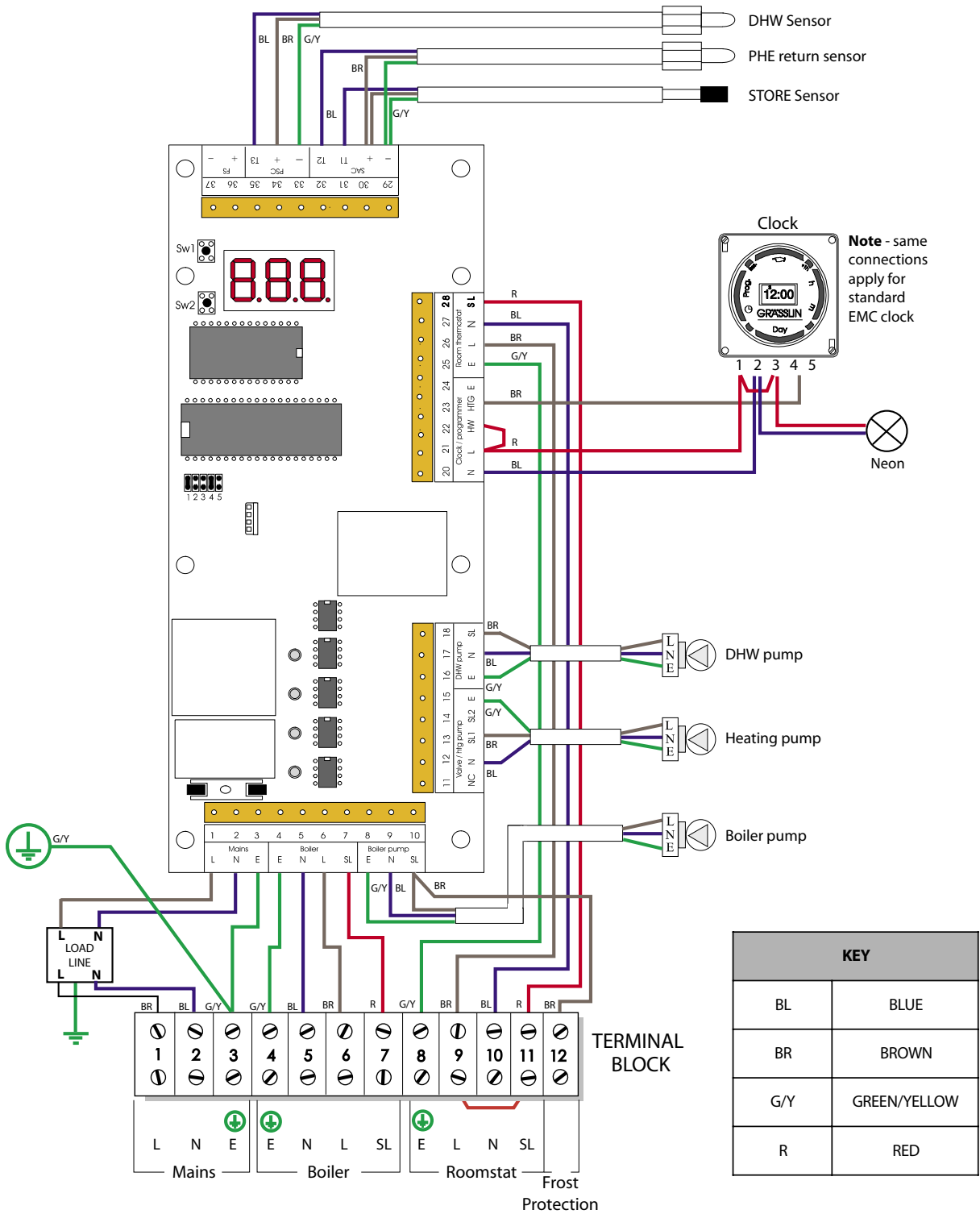

**Note** - same connections apply for standard EMC clock

KEY	
BL	BLUE
BR	BROWN
G/Y	GREEN/YELLOW
R	RED

Systemate<sup>2000</sup> with clock

ISSUE NO : 5	DATE : DEC 02
APPROVED	

# 2.0 INSTALLATION

## 2.2 INSTALLATION

### Electrical Connection - Standard Appliance

The Systemate 2000 is pre-wired to a 12 way terminal strip from the A.C.B. and plumbers are well able to complete the electrical installation provided they adhere strictly to the IEE Requirements for Electrical Installations BS 7671. A schematic arrangement of the wiring is shown on page 24.

All the terminals are suitably labelled.

**Note:** Do not attempt the electrical work unless you are competent to carry it out to the above standards.

Before commencing check that the power source is in accordance with section 1.2 Site Requirements and ensure that it is isolated.

Run the external wiring through the service slot provided in the base of the appliance.

It is recommended that the 3 core input cable from the isolator to the appliance is not less than 1.5mm<sup>2</sup> PVC grade to BS 6500.

Make the connections as shown opposite on the terminal strip provided.

**The appliance is provided with a link between terminals 9 and 11 on the terminal strip. This must be removed if a room thermostat is fitted see opposite.**

### No Clock Models

- If a remote clock is not being provided links will be required between 21/22 and 22/23.
- If a single remote clock is being provided a single link will be required between 21/22 to allow the appliance to provide hot water 24hrs/day.
- If a two channel clock is being provided no links will be required. (A two channel clock is normally only required to eliminate noise caused by the boiler firing during the night).
- Wire the connections from the clock as shown opposite.

Clamp the cables in the grips provided below the terminal strip and ensure all cables are routed to avoid hot surfaces.

**Note:** The appliance is provided with a 4.0mm earth cable from an earthing strap on the heating system bypass pipe to the earth stud on the wiring panel.

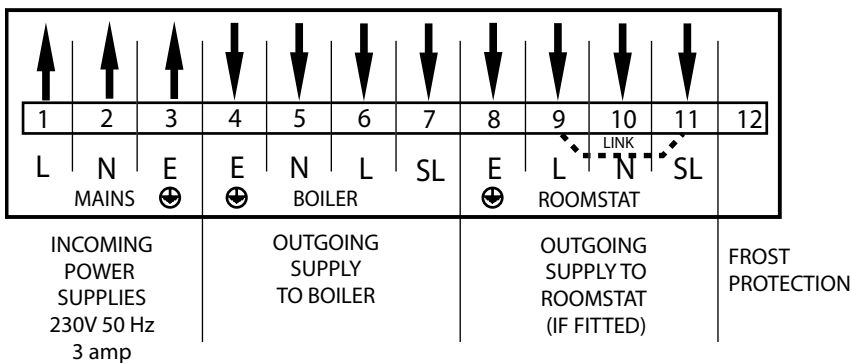

### Wiring guide from Clock to ACB

- Neutral - Terminal 20
- Permanent Live (to clock) - Terminal 21
- Hot Water Channel Switched Live (from clock) - Terminal 22 (only required with 2 channel clock)
- Heating Channel Switched Live (from clock) - Terminal 23

# 2.0 INSTALLATION

## 2.2 INSTALLATION

The **Systemate 2000** incorporates a **pump overrun for the boiler pump and terminal 6 on the terminal strip (as shown on page 22) should only be used if the boiler requires a permanent live for another purpose.**

The boiler manufacturers wiring instructions should be read in conjunction with this manual.

Before switching on the electrical supply check all the factory made terminal connections to ensure they have not become loose during transit.

### Frost Protection

When frost protection is required for the whole house or where a base temperature is required during cold weather, then a frost thermostat should be wired across plug in terminals 21 and 23 on the A.C.B board.

An alternative to fitting a frost thermostat would be to set the programmer to constant during the time required and adjust the room thermostat to a suitable setting.

When frost protection is required for the boiler circuit only a frost thermostat and pipe mounted thermostat should be fitted. The pipe thermostat should be mounted on the primary return pipe adjacent to the boiler and both thermostats should be wired from the terminal strip as shown opposite.

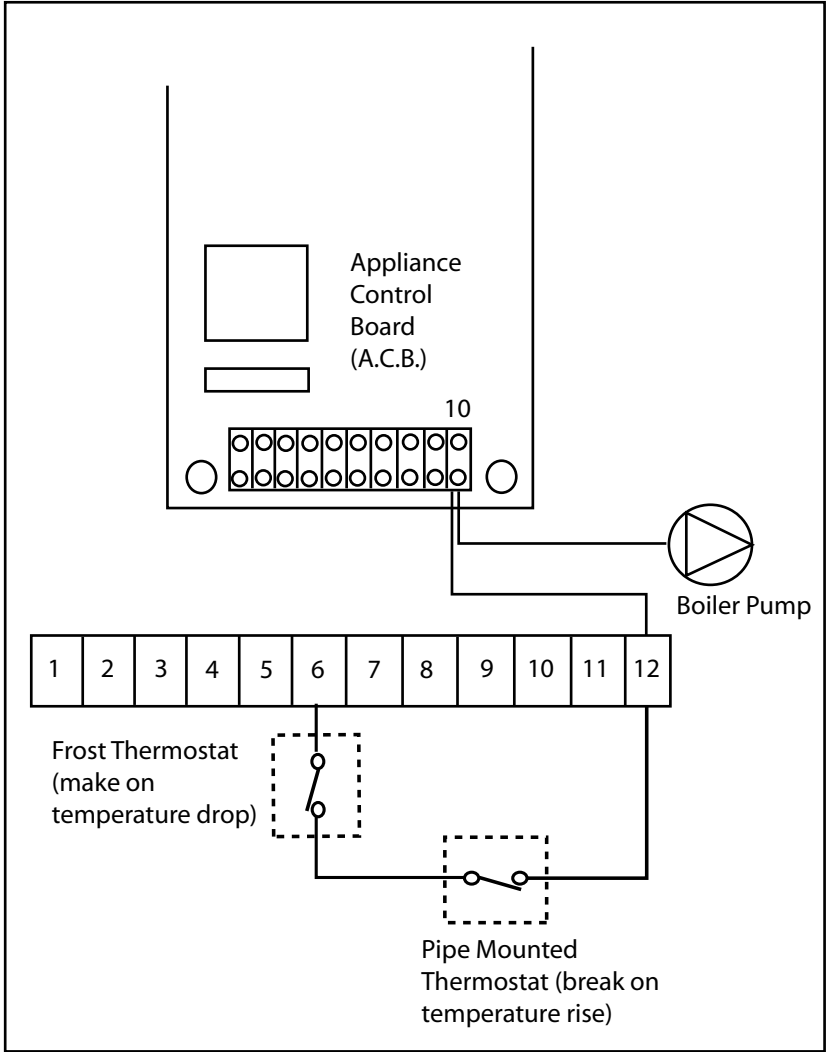

# 2.0 INSTALLATION

## 2.2 INSTALLATION

### WIRING DIAGRAM - SYSTEMATE<sup>2000</sup> WITH SWITCH

KEY	
BL	BLUE
BR	BROWN
G/Y	GREEN/YELLOW
R	RED
BLK	BLACK
Y	YELLOW
WH	WHITE

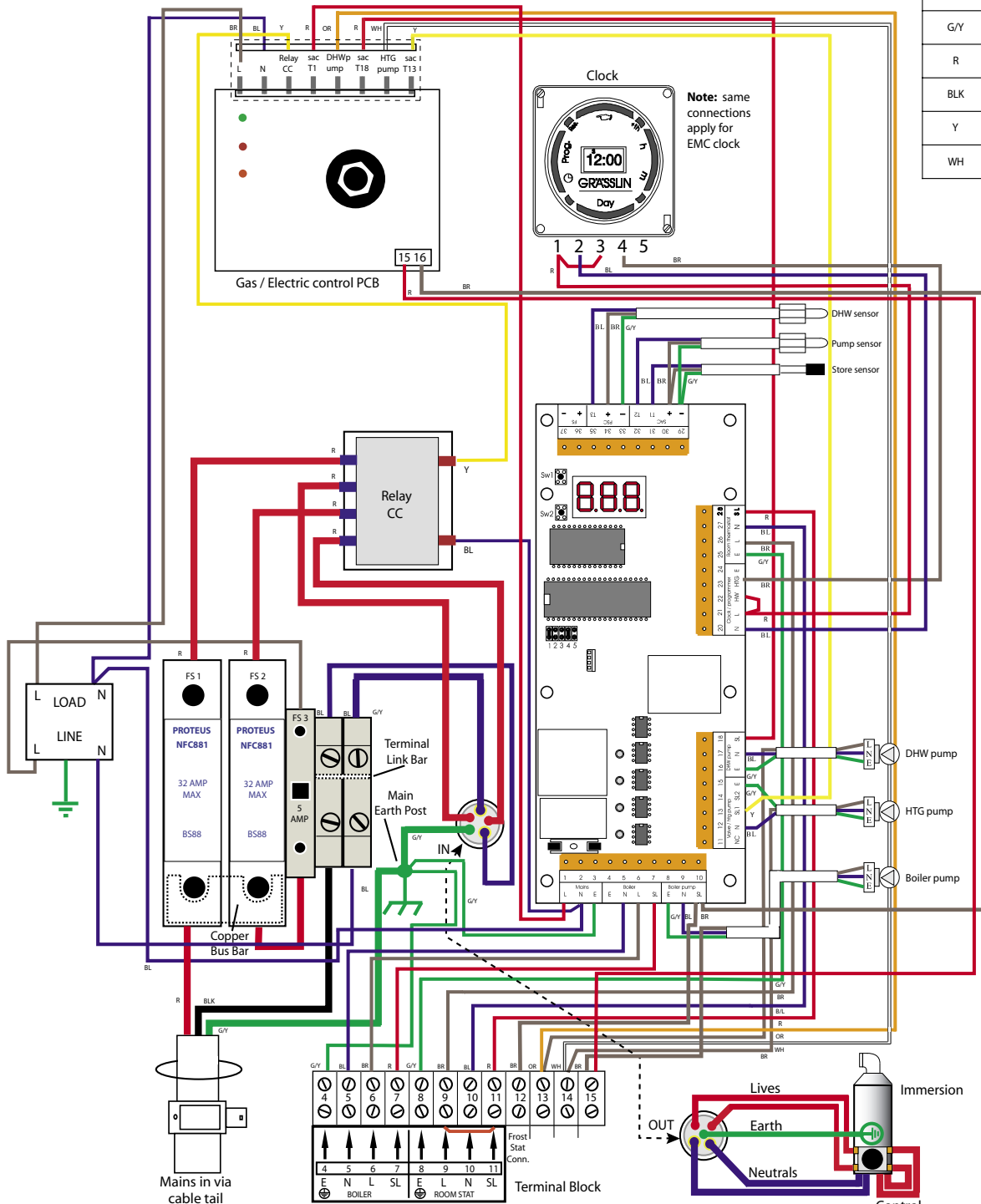

Systemate<sup>2000</sup> with SWITCH and clock fitted

ISSUE NO : 5.1	DATE : DEC 2002
APPROVED	

**WARNING: IF THE SYSTEMATE IS FITTED WITH AN OPTIONAL ELECTRIC BACKUP SYSTEM I.E. 'SWITCH':**

**IMPORTANT: ELECTRICIAN/INSTALLER PLEASE NOTE.**

**THE 2 x 25A FUSES FOR THE 'SWITCH' ELECTRIC BACKUP SYSTEM ARE SUPPLIED IN THE ACTIVE FUSE CARRIER. THE GAS BOILER CAN BE COMMISSIONED WITHOUT INSERTING THESE FUSES.**

**IT IS IMPORTANT THAT THE GAS BOILER IS COMMISSIONED BEFORE TESTING OR USING EMERGENCY SWITCH FACILITY.**

**AFTER THE GAS BOILER HAS BEEN COMMISSIONED CUT AND REMOVE THE PLASTIC TIE AND PUSH DOWN FULLY THE CARRIAGE TO COMMISSION THE SWITCH FACILITY.**

### 2.2 INSTALLATION

**Electrical Power Supplies - Systemate<sup>2000</sup> with Switch.**

A heavy duty electrical supply, see table on page 16, is required for this model and we recommend that a fully qualified electrician must undertake this work.

The electrical installation must comply with the IEE Requirements for Electrical Installations BS 7671.

**Note: do not attempt the electrical work unless you are competent to carry it out to the above standards.**

A 10.0mm<sup>2</sup> power cable is fitted with a 3 metre tail for the installer to connect to an isolator which must not be more than 2 metres away from the appliance.

A schematic arrangement of the internal wiring is shown on page 24.

All terminals are labelled.

Before commencing check that the power supply source (i.e. isolator) is in accordance with section 1.2 Site Requirements and ensure it is isolated.

Run the 10mm<sup>2</sup> cable provided through the service slot provided in the base of appliance and connect to the isolator as follows:-

red • live  
black • neutral  
green/yellow • earth

Check the cables are secure in the grips provided below the terminal strip and ensure they are not in contact with any hot surfaces.

The recommendations contained under Electrical Connection - Standard Appliance should be followed when connecting a remote clock, room thermostat, boiler etc.

**WARNING : DO NOT SWITCH ON ELECTRIC BACKUP, IF FITTED, UNTIL THE APPLIANCE HAS BEEN FULLY COMMISSIONED i.e. PRIMARY STORE IS FILLED AND VENTED.**



## 2.3 COMMISSIONING

Open the incoming stop valve and fill the domestic mains cold and hot water systems.

Check and adjust as necessary the expansion vessel air pressure to the figure specified (normally 1.0 bar).

Fill the whole of the primary heating system with potable water through the filling loop provided adjacent to the boiler to the pressure required (normally 1.0 bar).

During filling vent air as necessary from the high points of the system including the manual air vents provided on the appliance and the feed to the expansion vessel.

Fill the appliance i.e. SysteMate 2000 through the feed and expansion cistern flush and refill.

Check the water level in the feed and expansion cistern and adjust the ballvalve if necessary.

Check the warning pipe is installed correctly, has a continuous fall and is not blocked i.e. discharges water freely.

Check the whole of the primary heating and domestic hot and cold distribution systems for leaks.

It is essential that all systems function properly for optimum performance.

To achieve this, the primary system should be commissioned in accordance with good practice and generally in accordance with the requirements of BS 6798, BS 5449 and BS 7593.

Full details of the requirements are given in PAS 33:1999 under Section 10 Commissioning.

When using either cleansing or corrosion inhibitor chemical, the manufacturers instructions must be followed.

### **Cleansing the Primary System**

**It is very important to ensure that the Primary system is cleaned using a suitable cleansing agent such as Sentinel X300 or Fernox Superfloc to ensure that any flux residues/installation debris are removed.**

The volumes/concentration should be calculated in accordance with the manufacturers instructions allowing the volume for the primary coil shown in the Table in 1.2 Technical Data.

### **Primary Water System Treatment**

Although the SysteMate 2000 has no special water treatment requirements, the radiators and other parts of the circuit will benefit from the application of a scale and corrosion inhibitor such as Sentinel X100 or a Protector such as Fernox MB1.

The volumes/concentration should be calculated in accordance with the manufacturers instructions allowing the volume for the primary coil shown in the Table in 1.2 Technical Data.

### **POWERFLUSHING/CLEANING OF THE HEATING SYSTEM**

If it is proposed to 'powerflush' the heating system we would recommend that the SysteMate appliance is isolated from the heating system being cleaned. Failure to do this could seriously damage the appliance.

When carrying out the work always comply fully with the manufacturers instructions for the powerflushing equipment being used.

If in any doubt please consult our Technical Helpline.

# 2.0 INSTALLATION

## 2.3 COMMISSIONING

Once the system is finally filled turn down the servicing valve for the ballvalve in the F & E cistern to the point where the warning/overflow will cope with the discharge arising from a ballvalve failure.

If an overflow is not provided ensure the temporary connection to the ballvalve is isolated and removed from its connection to the cold water supply.

### Cleansing Hot/Cold Water System Treatment

Fully flush and, when necessary, chlorinate the hot and cold water system in accordance with the recommendations in the Model Water Byelaws and BS 6700.



### Commissioning the Systemate Control System

The Systemate control system will automatically commission itself to match the actual performance of the installed boiler but the thermostat on the boiler should be left at maximum initially.

The control system/A.C.B has been initialised at the factory and will operate automatically.

However, the operation of the control system should be checked as follows on the A.C.B (shown opposite).

1. Set the boiler thermostat to MAXIMUM
2. Switch off heating on the clock/ programmer and room thermostat
3. **Check the jumper settings are correct. These must all be in the correct positions for the appliance to work correctly - see opposite for options.**
4. Switch on the mains supply.

The A.C.B. will automatically commission itself to suit the system/boiler and the dot after the  ON the LED display will flash: e.g.  ON

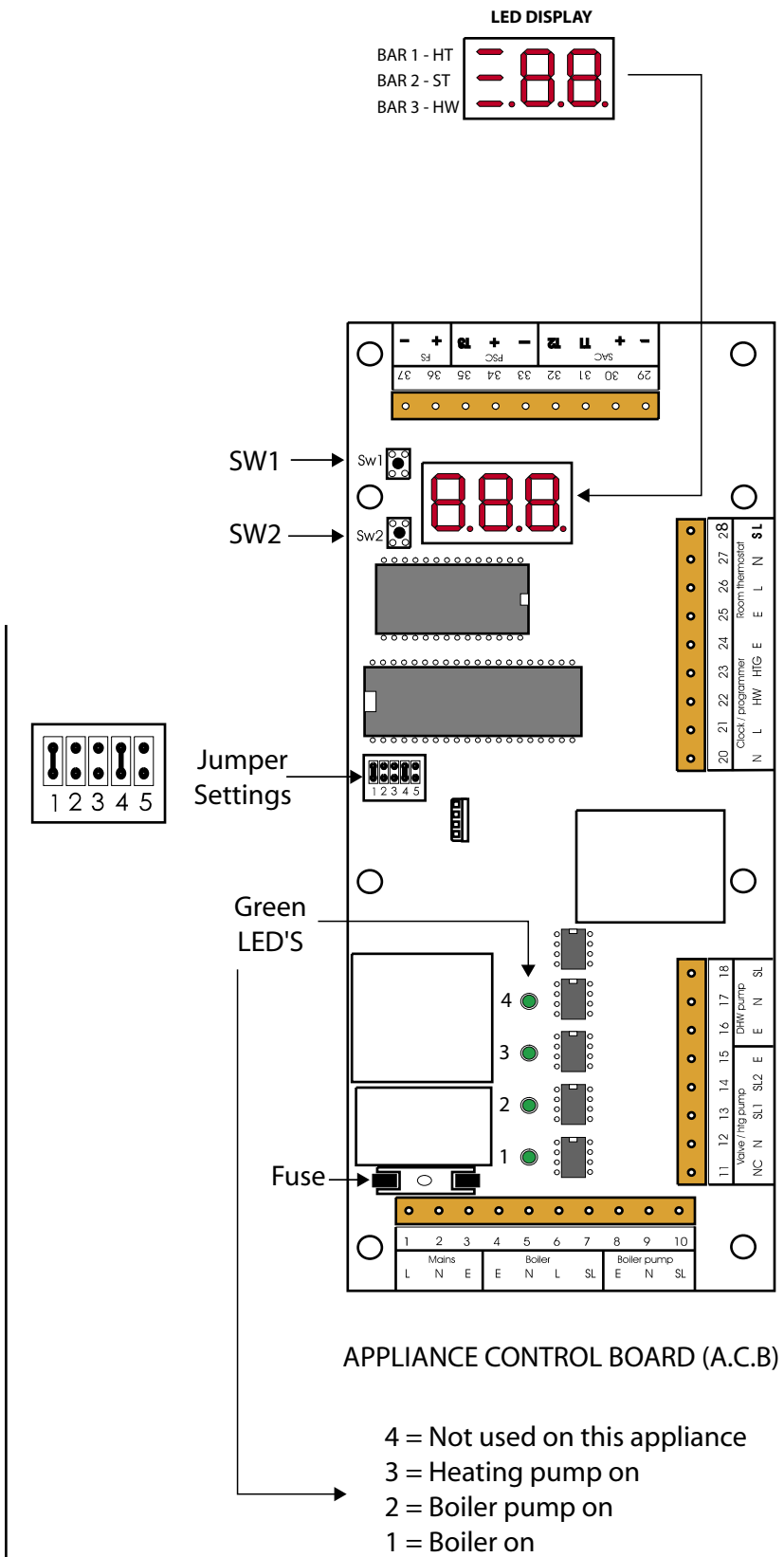

## 2.3 COMMISSIONING

The control system is now initialised. The operation of the controls can now be checked.

1. Horizontal LED bar 2 'store' will be lit.  
Boiler and boiler pump will be running and green LED's 1 and 2 on the A.C.B will be switched on.

**Note:** The controls within the A.C.B will not allow the heating system to function until the store temperature has reached 64°C. Therefore although the LED bar 1 'HT' will light when heating is switched on, the heating pump (Green LED -3) will not switch on if the store temperature is less than 64°C. Time will need to be allowed for this to happen during initial commissioning. This will vary depending on the boiler size and the model of the SystemeMate 2000 being used.

2. Once a temperature of 64°C has been reached on the thermal store, switch on space heating clock/programmer and room thermostat.
  - Horizontal LED bar 1 'HT' will light.
  - Green LED 3 on the A.C.B will switch on.  
Heating pump will run.
3. Switch off space heating on clock/programmer or room thermostat
  - Horizontal LED bar 1 'HT' will switch off.
  - Green LED 3 on the A.C.B will switch off.  
Heating pump will switch off.
4. Open the hot tap
  - Horizontal LED bar 3 'DHW' on the LED display will light.
  - Domestic hot water pump will run.
5. Close the hot water tap
  - Horizontal LED bar 3 will switch off
  - Domestic hot water pump will continue to run for a short period of time before switching off.
6. The A.C.B incorporates a 3 minute boiler pump overrun facility. Check green LED 2 remains lit for this period of time when the boiler switches off i.e. the thermal store reaches temperature.

The control functions have now been checked.

Let the boiler heat the store and when the store is satisfied, i.e. green LED's 1 and 2 on the A.C.B are off, the radiator circuit and hot water can be checked and balanced in the normal way.

The boiler thermostat should be left **at maximum** for optimum performance/efficiency.

### When commissioning the system

- If the boiler is range rated, then adjust it to the **maximum** heat input.
- Check the boiler thermostat is set to maximum.
- Set the boiler pump speed so that the temperature difference across the boiler is **about 11°C** - when the space heating is off.
- Balance the heating system and set the heating system pump speed so that the temperature difference across the flow and return is **not greater than 11°C**.

**NOTE :** When using the SystemeMate with a Keston C25 comply with the following :

The heating circuit and boiler circuit pumps in the SystemeMate must not be disconnected. Although it is not necessary, the pump in the boiler may be disconnected (after consultations with the manufacturers).

The speed of the boiler circuit pump in the SystemeMate should be adjusted to give about a 15°C temperature rise across the boiler. However, if this starts circulation in the heating circuit when the heating is off, the speed should be increased.

The speed of the heating circuit pump in the SystemeMate should be adjusted to give about an 11°C temperature difference across the heating circuit.

- Check the DHW plate heat exchanger pump is set to maximum.
- Check that there is no overflow when the whole of the system is fully up to temperature.
- Check that the heating system pressure is not greater than 2.0 bar when the whole of the system is up to temperature.
- The domestic hot water pump should always be set at pump speed 3.

Because the A.C.B is able to adjust to suit the water temperatures delivered by the boiler the thermostat should always be set at maximum during commissioning.

The temperature settings established during commissioning can be checked using push button switches sw1 and sw2 on the PCB as described in section 3.3 Fault Finding.

The clock/programmer provided on the appliance controls the heating system only and should be set to suit the householders requirements using the instructions shown on the separate leaflet and the label on the front of the appliance. If the appliance is fitted with Switch (see page 17 and 25) the boiler should be switched off and Switch operated to ensure it is working correctly.

- When the selector knob is not in normal position, the PCB, room thermostat and the time clock are electrically isolated.
- When the selector knob is in HW only position the plate heat exchanger pump will run continuously at full speed.
- When the selector knob is in the HW and HTG position, the plate heat exchanger pump and the heating pump will run continuously.

### 2.3 COMMISSIONING

**This product is covered by the 'Benchmark' scheme and a separate commissioning/service log book is included with this product. This must be completed during commissioning and left with the product to meet the Warranty conditions offered by Gledhill.**

On completion:-

1. Do ensure that the electrical connections (e.g. mains supply, room thermostat) to the unit are correct and tight.
2. Do ensure that the functioning and control of the system is explained to the occupant.

These Instructions should be placed along with the component manufacturers instructions in the pocket provided on the rear of the front panel. The front panel should then be refitted.

**NOTE:-** With sealed heating systems air is released from the water during the first few weeks of operation. This must be vented and the system repressurized.

#### Important Do's and Don'ts

**DO** check the incoming mains water pressure and flow rate are adequate. (The preferred range of mains pressure is 2-3bar).

**DO** check that all plumbing and electrical connections are in accordance with the labelling on the thermal store.

**DO** check and ensure the air pressure side of the expansion vessel is set at 1.0 bar (or as specified)

**DO** ensure the Systemate is fitted on a sealed primary (i.e. closed) system and the boiler is suitable (i.e. fitted with an overheat thermostat)

**DO** adjust the ballvalve so that the water level in the appliance F & E cistern when the system is cold is correct and does not overflow when the appliance is at maximum temperature

**DO** turn down the servicing valve for the ballvalve in the F & E cistern, once the system is finally filled, to the point where the warning/overflow pipe will cope with the discharge arising from a ballvalve failure.

**DO** make sure that there is adequate clearance above the appliance F & E cistern to service the ballvalve.

**DO** ensure that the range rated appliances are set at the **highest output** and the boiler thermostat is set to **maximum** for all boilers.

**DO** insulate any exposed pipework in the Systemate cupboard.

**DO** plumb the overflow/warning pipe (if fitted) in a 20mm internal diameter pipe material which is suitable for use with a heating F & E cistern, in accordance with BS 5449 (such as copper) and ensure it has a continuous fall and discharges in a conspicuous external position.

**DO** check the pump settings

**a.**The boiler pump should be set to give a temperature difference across the boiler of 11°C or less.

**b.**The heating pump should be set to give a temperature difference across the flow and return of not more than 11°C.

**c.** The hot water plate heat exchanger pump should be set at **maximum**.

**DO** ensure that the bypass valve for the heating system is set correctly.

**DON'T** use a combined feed and vent on Systemate installations.

**DON'T** use pipe smaller than 28mm between the boiler and the Systemate when the boiler rating exceeds 20kW (about 68,000 Btu/h).

**DON'T** operate the 'switch' backup facility until the system is fully fitted, vented and commissioned.

## 3.0 SERVICING

### 3.1 ANNUAL SERVICING

No annual servicing of the Systemate 2000 is necessary.

However, if required, the operation of the controls and a hot water performance test can be carried out when servicing the boiler to prove the appliance is working satisfactorily and within its specification.

### 3.2 CHANGING COMPONENTS

Free of charge replacements for any faulty components are available from Gledhill during the in-warranty period (normally 12 months).

However, if any component is damaged during installation e.g. the A.C.B., by incorrect wiring by the installer, a new replacement must be ordered and paid for.

After this, spares can be obtained direct from Gledhill using the 'Speed Spares' service, or through any of the larger plumbers merchants/ specialist heating spares suppliers.

Help and advice is also available from the Technical Helpline on 01253 474401.

However, all components are readily accessible and can be changed quickly and easily by the installer using common plumbing practice.

If it is necessary to replace any of the pumps fitted to the appliance the pump head (motor pack) only should be removed as recommended by Grundfos. Assuming it is within warranty this will be accepted by a merchant as being covered by the Grundfos national service exchange agreement, as long as it is a complete pump i.e. alleged faulty motor pack and new base is left with the merchant. It is important when a pump has been replaced to ensure that any air is adequately vented.

## 3.0 SERVICING

### 3.3 SHORTS PART LIST

Key No.	Description	Manufacturer	Stock Code No.	Gas Council Part No.
1	Feed and expansion cistern	Polytank	XB343	
2	Ball float	Masfield/Epson	FT429	370 506
3	Ballvalve	Beta	FT207	370 505
4	Single check valve	Detail Plastic Co	GT048	E37 479
4	Brass housing	Midland Brass Co	GT049	
5	15/50 pump with 1½" connections	Grundfos	XB001	384 288
6	15/60 pump with 1½" connections	Grundfos	XB241	
7	22mm ball type pump valve	Vemco	XB121	E26 010
8	28mm ball type pump valve	Vemco	XB122	
9	Plate heat exchanger	Swep	GT017	E05 664
10	Appliance control board (A.C.B)	Elok	XB255	E39 158
11	Store sensor	Elok	GT149	E26 022
12	PHE return sensor	Elok	GT153	E26 024
13	D.H.W. temperature sensor	Elok	GT153	E26 024
14	Electro-mechanical clock	Grasslin	XB215	385 873
15	Digital clock	Grasslin	XB216	385 874
16	Switch control thermostat (64T21)		XB344	
17	Switch heating element		XB341	
18	Switch control p.c.b.	Prelude	XB386	
19	Switch control knob		XB378	
20	AC30 fuse base	Proteus	XB388	
21	Power relay		XB298	E39 163
22	20mm high break fuse 5amp		XB382	
23	3025 LC fuse		XB364	E39 161
24	12 Ltr. Expansion Vessel	Reliance	XG164	
25	25 Ltr. Expansion Vessel	Reliance	XG165	
26	'Y' Type strainer		XB314	
27	Flow regulator		GT086	
28	Electronic Noise Filter		XB307	

# 3.0 SERVICING

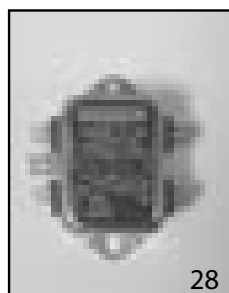
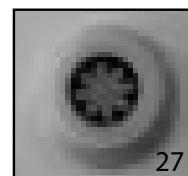
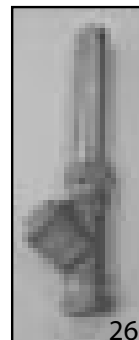
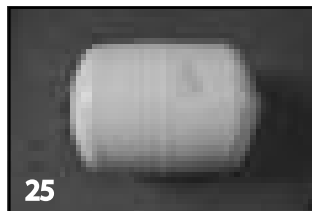
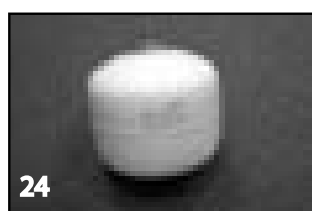
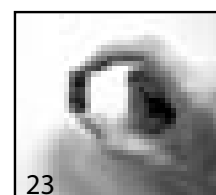
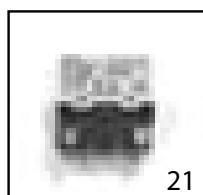
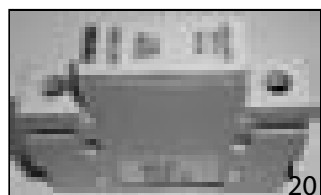
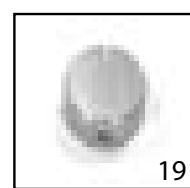
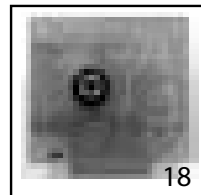
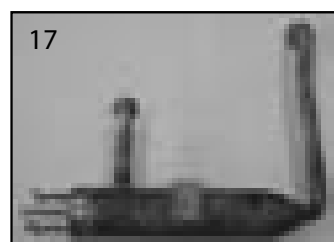
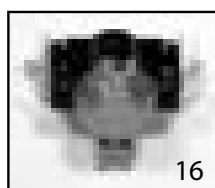
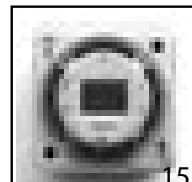
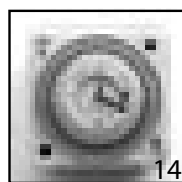
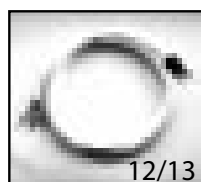
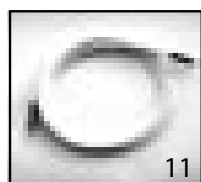
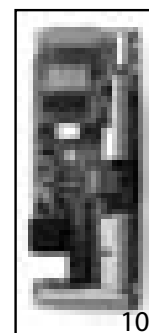
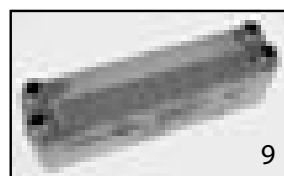
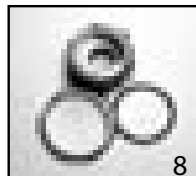
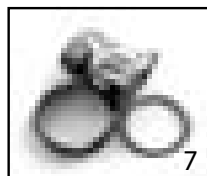
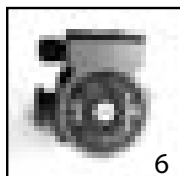
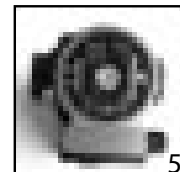
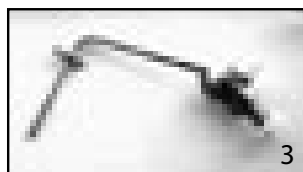
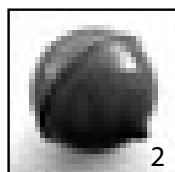
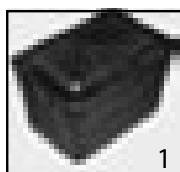

## 3.4 FAULT FINDING

Despite everyone's best efforts some problems could occur and lead to complaints from the householder.

Complaints can be grouped into the following three main categories:-

1. The system is noisy
2. Hot water service is unsatisfactory
3. Space heating is unsatisfactory

The following checks should be carried out by the installer before calling the manufacturer.

### 1. Causes of a 'Noisy' System

Noisy pump operation

**Check** the level of water in the Appliance F & E cistern - adjust and vent the plate heat exchanger pump and system if necessary.

**Check** and if necessary adjust the pressure in the heating/primary system and vent the system.

**Check** the pump speed setting of the boiler pump - reduce if necessary but ensure that the temperature rise across the boiler does not exceed 11°C.

**Check** the pump speed setting of the heating pump - reduce if necessary but ensure a temperature difference across the flow and return does not exceed 11°C.

**Check** and adjust if necessary the heating system bypass valve.

**Check** that the radiators are correctly balanced.

Noisy boiler operation

**Check** the flow rate through the boiler at full gas rate by measuring the temperature rise across the boiler. If the temperature rise is greater than 11°C, then increase the pump speed.

**Check**

and adjust if necessary the pressure in the heating/primary system.

**Check** and vent the system if necessary.

Noise when hot water tap is opened

If the plate heat exchanger pump is noisy when the hot water tap is opened, then check the level of water in the appliance F & E cistern and vent the pump if necessary.

Water hammer - loose pipework and/or tap washers.

### 2. Causes of 'Unsatisfactory Hot Water Service'

**Check** that the Systemate is full of water i.e. level of water in the appliance F & E cistern is correct when system is cold.

**Check** boiler thermostat - this should be set at maximum.

**Check** that the boiler flow temperature is adequate when it stops firing. Boilers should provide a flow temperature of  $82 \pm 3^\circ\text{C}$  but temperatures as low as  $76^\circ\text{C}$  will allow the Systemate 2000 to provide a satisfactory performance.

**Check** that the store is charging to at least  $73^\circ\text{C}$ .

**Check** that the hot water plate heat exchanger pump starts when the hot water tap is opened and stops shortly after it is closed.

**Check** that the plate heat exchanger pump is set at maximum speed.

**Check** that the space heating and hot water load is not greater than the boiler output and that the Systemate 2000 model is suitable for the type of dwelling.

If all the above checks are satisfactory then it is possible that the performance of the heat exchanger is impaired by scale. In this case the hot water flow rate will be noticeably less than the cold water flow rate. Replace with a factory exchange unit and re-check hot water performance.

### 3. Causes of 'Unsatisfactory Space Heating'

**Check** the boiler thermostat - this should be set at maximum.

**Check** that the boiler flow temperature before it is switched off is adequate - it should not be less than  $80^\circ\text{C}$ .

**Check** the operation and the settings of the heating programmer and the room thermostat.

**Check** that the heating system pump is circulating the water to the radiator circuit.

If some rooms are not being heated properly, then balance the system, adjust the pump speed and check the operation of the thermostatic radiator valves (if fitted).

### Overflow from Feed and Expansion Cistern

**Check** that the controlled level of water in the cistern is no higher than necessary. Adjust if required.

The ACB can be used to establish/check the operating and set temperatures of the appliance as well as identify faults on any of the 3 sensors. This is done by operating switches SW1 and SW2 as shown opposite and reading the LED display. (See page 27)

Store T1, PHE T2, and DHW T3 indicate the current value being read by the store, PHE and DHW sensors respectively. The location of the sensors is shown in the diagram shown opposite/below.

T1 ON and T1 OFF show the store temperature set points which are automatically reset on each boiler cycle to match the temperature produced by the boiler.

T1 ON shows the temperature at which the store will call for heat, i.e. signal the boiler to fire.

T1 OFF shows the temperature at which the store will be satisfied, i.e. signal the boiler to switch off.

### POWERFLUSHING/CLEANING OF THE HEATING SYSTEM

If it is proposed to 'powerflush' the heating system we would recommend that the Systemate appliance is isolated from the heating system being cleaned. Failure to do this could seriously damage the appliance.

When carrying out the work always comply fully with the manufacturers instructions for the powerflushing equipment being used.

If in any doubt please consult our Technical Helpline.



# 3.0 SERVICING

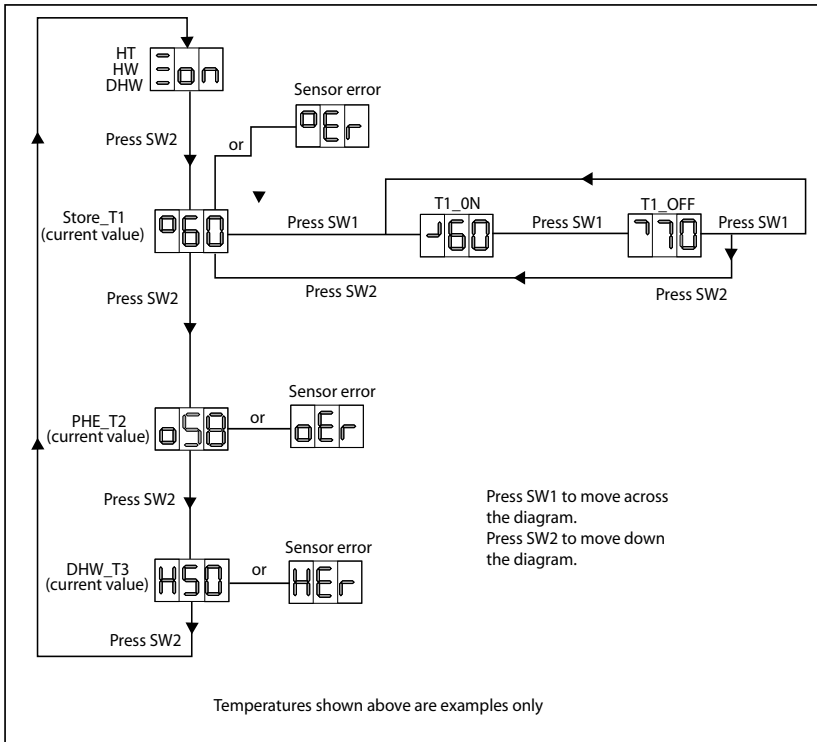

In addition to the main LED display the ACB has four green LED'S which can be used to check a supply is being provided when required to the Boiler (LED 1), Boiler pump (LED 2) and Heating pump (LED 3). LED 4 is not used on this appliance.

The following procedure should be followed to carry out these checks.

- Switch off mains
- Check and if necessary insert correct jumpers (1 & 4) to suit appliance type
- Insert jumper 5
- Switch on mains
- The PCB will carry out functional checks and then stop. When complete the LED display will show ON.
- Switch off mains
- Remove jumper 5
- Switch on mains to put into normal operating mode

During the functional checks the green LED's 1-4 will be switched on and then off at 5 second intervals and the output number will be indicated on the LED display.

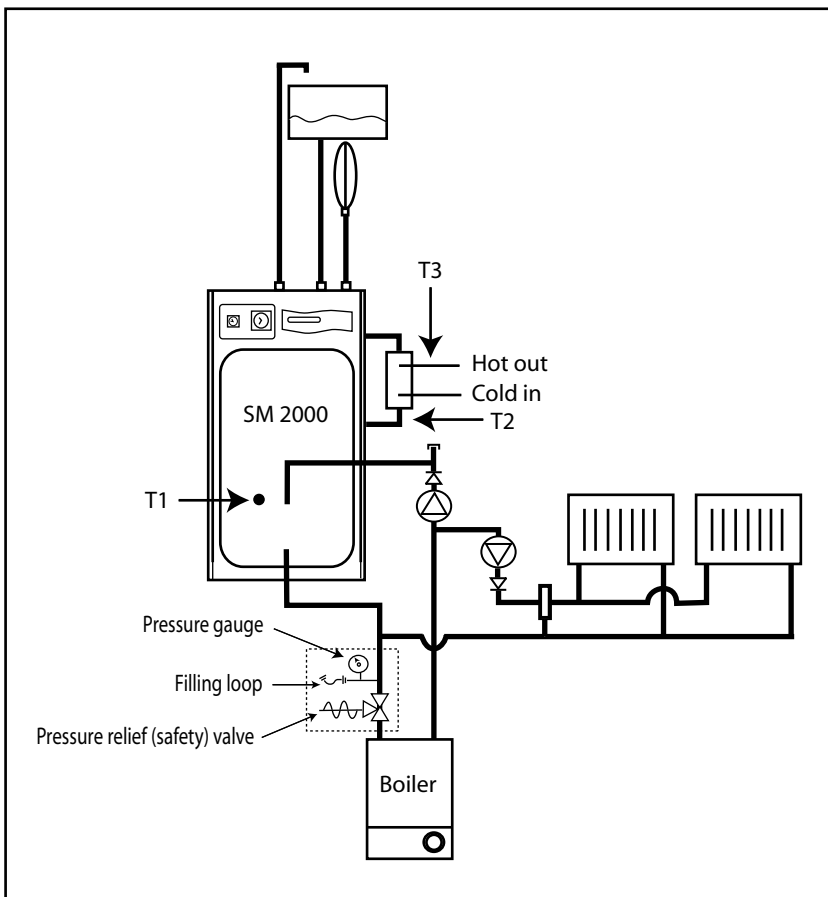

**Note: If the A.C.B. board is replaced it will re-initialize itself automatically.**

**The operation of the system controls/operation can then be checked.**

**The same appliance control board is used on a number of appliances and the jumpers MUST be in the correct position for the appliance to work satisfactorily.**

**See section 2.3 Commissioning for details.**

If the problem cannot be resolved and the appliance is fitted with the switch emergency electric backup this should be switched on and operated in accordance with the instructions on the label fitted to the appliance until the installer/manufacturer can attend.

**When requesting a visit from the manufacturer the installer must have the completed 'Benchmark' commissioning/service record sheet to hand to enable help to be provided.**

## WATER SAVINGS

WATER RELATED COSTS CAN BE REDUCED BY GOOD PLUMBING PRACTICE.

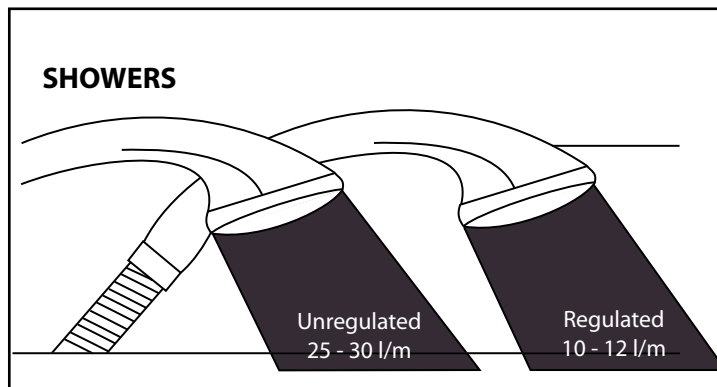
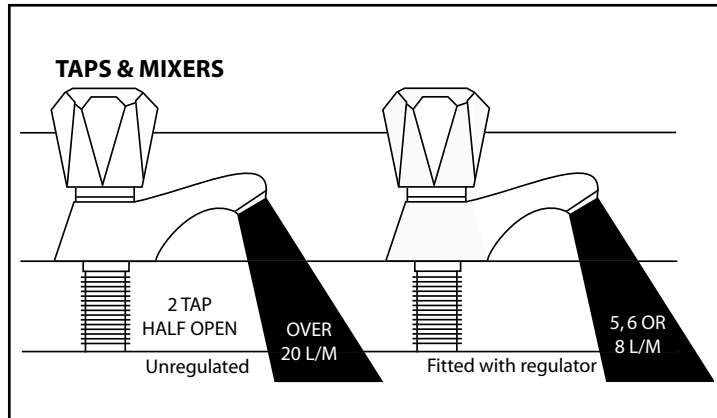

Vast quantities of water are needlessly run off to waste due to Taps, Mixers and Showers discharging flow rates far in excess of the rates required for them to perform their duties.

The contrasting flow rates shown on this leaflet clearly illustrate the savings that can be made whilst still providing a good performance.

British made Aquaflow Regulators provide constant flow rates by automatically compensating for supply pressure changes between 1 bar & 10 bars.

To facilitate installation into the wide range of plumbing equipment which is encountered in the U.K, Four Fixing Options are available:-

### OPTIONS FOR SHOWERS

1. MXF "DW" Range - For fitting behind Fixed Shower Heads or onto Flexible Hoses for Handshowers (preferably onto the inlet end when lightweight hoses are used).
2. Compression Fitting Range. "In Line" regulators as in Option 4 for Taps & Mixers.

Information by courtesy of

**AQUAFLOW REGULATORS LTD**

Haywood House, 40 New Road, Stourbridge, West Midlands DY8 1PA  
TELEPHONE (01384) 442611 FAX: (01384) 442612

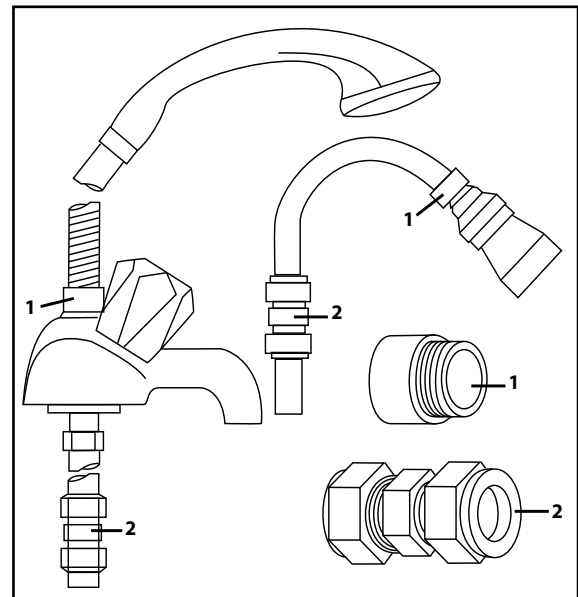

### 4 FIXING OPTIONS FOR TAPS & MIXERS

1. MK Range - Combined Regulators & Aerators for screwing onto Taps & Mixers with internal or external threads on their noses. Anti Vandal models also available.
2. MR05-T Range - Internal Regulators. Push-fit into Tap or Mixer seats. Produced in three sizes - 12.5mm (BS1010), 12mm & 10mm, Flangeless models also available for Taps with Low Lift washers.
3. MXF Standard Range - Screw on tail models for Taps & Mixers. Fix onto the tails before fitting the tap connectors. Available in 3/8", 1/2", 3/4" and 1" BSP.
4. Compression Fitting Range - "In Line" regulators housed in 15mm & 22mm CXC Couplers & Isolating Valves. <sup>UMPS</sup> ~~UMPS~~ by the Water Research Centre. Isolation valves available for slotted screwdriver operation or with coloured plastic handles. Now available also in plastic bodied push-fit couplers & valves.

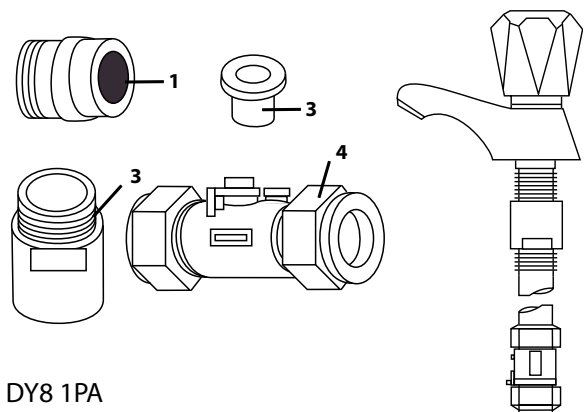

# APPENDIX B

## MANIFOLDS

Manifold type: 1 - Stock Code MIP 050 (one bathroom, one en suite shower room, one cloakroom)			
Flow regulator (litres/minute)	Terminal fitting	Hot water manifold outlets Quantity	Cold water manifold outlets Quantity
18	Bath tap	1	1
8	Hand basin	3	3
10	Kitchen sink	1	1
8	Toilet cistern	None	3
8	Shower	1	1
8	Washing machine	1	1
8	Dishwasher	None	1
<b>Total</b>		<b>7</b>	<b>11</b>

Two sets of manifolds are available as an optional extra. Each set comprises a separate hot and cold water manifold. Both are provided with a 22mm inlet connection located centrally. All outlet connections are 15mm compression. The centre to centre dimension of each branch is 55mm.

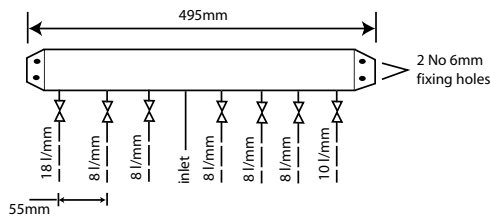

A

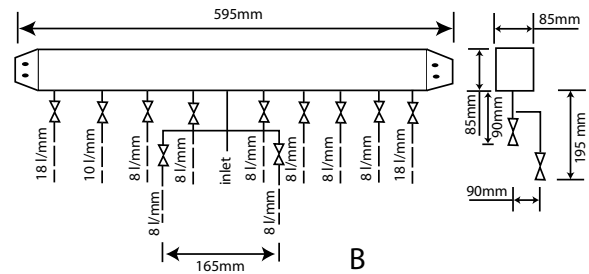

B

Manifold type: 2 - Stock Code MIP 060 (two bathrooms, one en suite shower room, one cloakroom, one utility room)			
Flow regulator (litres/minute)	Terminal fitting	Hot water manifold outlets Quantity	Cold water manifold outlets Quantity
18	Bath tap	2	2
8	Hand basin	3	3
10	Kitchen sink	2	2
8	Toilet cistern	None	3
8	Shower	1	1
8	Washing machine	1	1
8	Dishwasher	None	1
<b>Total</b>		<b>9</b>	<b>13</b>

The arrangement of each manifold is supplied as shown. This provides the best balance of flows but the flow regulators/duty of each branch can be changed if required as long as a reasonable balance is maintained. If it is necessary to change or clean the flow regulator this can be done without needing to drain the system by closing the valve and removing the screwed cover below the white plastic cover.

The manifolds are designed to be used with plastic pipework and are supplied complete with isolation valves and flow regulators on each branch. They would normally be installed in the same cupboard as the thermal storage appliance (on page 36) but can be installed in another cupboard close to the appliance if required.

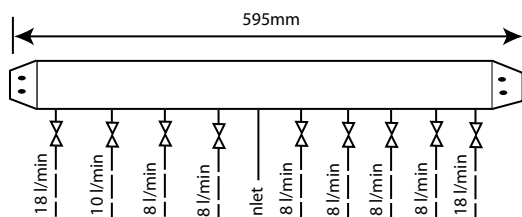

C

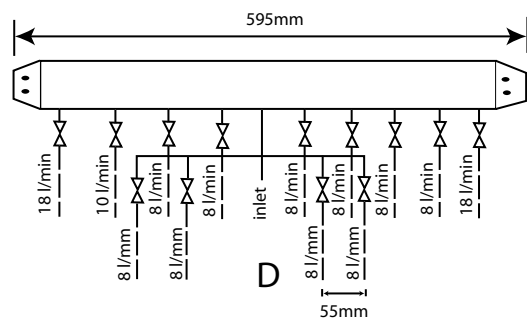

D

# APPENDIX B

*An optional location where cupboard space is tight*



The pressure loss through a flow regulator at the designated flow rate is about 1.8 bar. Therefore for the flow regulator to control the flow rate at pre-set level, the inlet pressure must be greater than 1.8 bar. If the inlet pressure is lower, the flow rate will be correspondingly less than the pre-set values.

The maximum equivalent pipe lengths from the manifold to the terminal fittings can be estimated from the above information and the resistance characteristics of the pipes. The examples presented below are for 15mm copper pipe in table 1 and for plastic pipework in table 2.

*The preferred solution where space will allow*



**Table 1 : Maximum equivalent pipe length in 15mm copper**

Inlet pressure (bar)	Maximum equivalent length of pipe (m)		
	@ 8 l/m	@ 10 l/m	@ 18 l/m
2.0	33	13	5
2.5	110	45	17
3.0	200	80	30

**Table 2 : Maximum equivalent pipe lengths in plastic pipe**

Inlet pressure (bar)	Maximum equivalent length of pipe (m)		
	@ 8 l/m	@ 10 l/m	@ 18 l/m
2.0	10mm: 2.0	10mm: 1.3 15mm: 12.5	15mm: 4.5 22mm: 40
2.5	10mm: 4.0	10mm: 2.6 15mm: 25.0	15mm: 9.0 22mm: 80.0
3.0	10mm: 6.0	10mm: 3.9 15mm: 37.5	15mm: 13.5 22mm: 120

# APPENDIX B

The size of the distribution pipes supplying the manifold should be calculated using the method set out in BS 6700. A typical diagrammatic arrangement of a system using Manifold Type 1 is shown below. This is only meant to show the principles involved and the actual connection of fittings to the manifold will need to suit the arrangements shown in page 35.

**Note 1** - If it is proposed to fit chemical water treatment such as a water softener this should be fitted in this location and the cold water branch in the sink should be branched off the cold water main prior to the treatment device instead of the cold water manifold.

Any other isolating/control valves and backflow protection devices should be provided as necessary to comply with the Water Regulations.

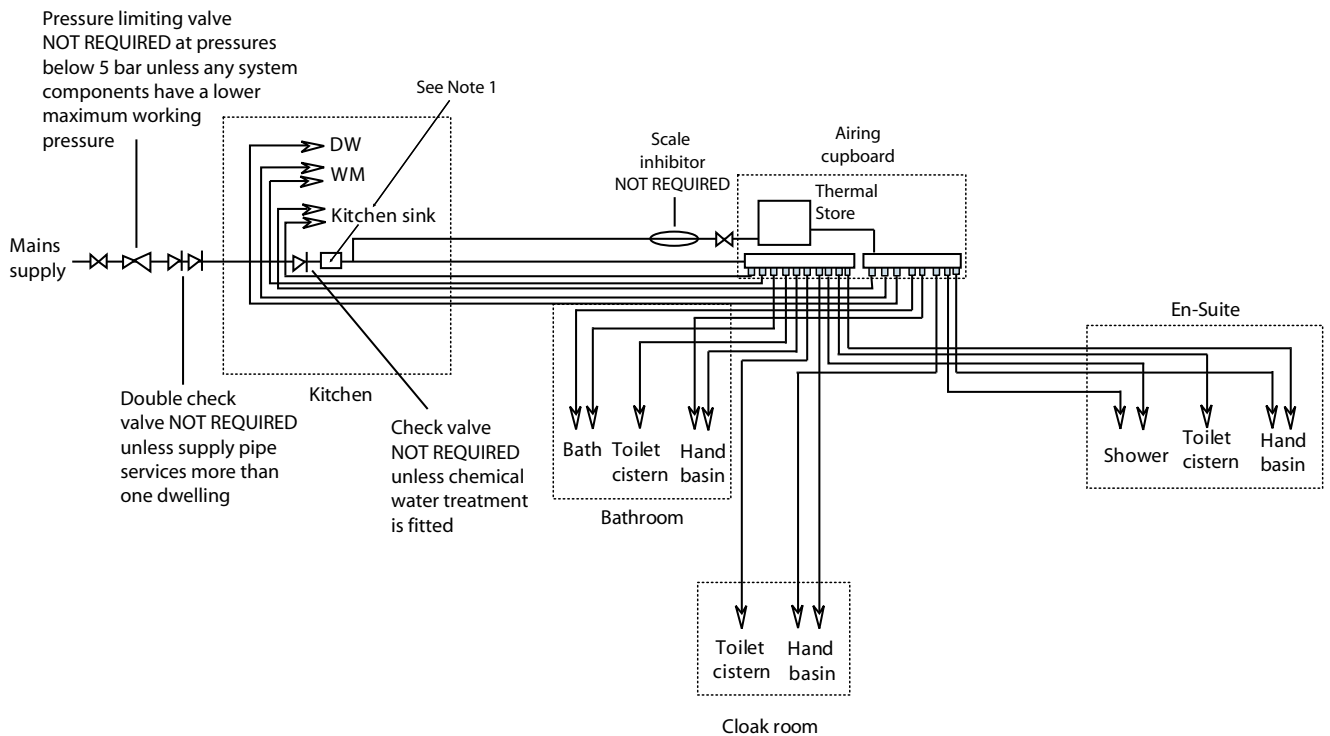

1. We only do business upon the Conditions which appear below and no other. Unless we so agree in writing these Conditions shall apply in full to any supply of goods by us to the exclusion of any Conditions or terms sought to be imposed by any purchaser. These Conditions of Sale and Warranty Terms override those which are contained on the Invoice Forms and all Sales are now subject to these Conditions of Sale and Warranty terms only.

## 2. PRICE

Orders are accepted at the price ruling at the date of receipt of order, this price is our last published list price plus a supplement to allow for any increase in the price of copper between the dates of publication of our price lists ("the copper price supplement"). An order may not be cancelled or varied after acceptance without the written consent of the company. Such cancellation or variation shall be subject to such reasonable charges as may be appropriate.

## 3. SPECIFICATION

The goods are supplied in accordance with the Specifications (if any) submitted to the Purchaser and any additions and alterations shall be the subject of an extra charge. Any goods not so specified shall be in accordance with our printed literature or the literature of any of our component suppliers (subject to any modifications made since publication). If we adopt any changes in construction or design of the goods, or in the specification printed in our literature, the Purchaser shall accept the goods so changed in fulfilment of the order.

## 4. PAYMENT

The invoice price of goods shall be payable within 30 days of despatch by us of our invoice for the goods or such longer time as may be stated by our quotation or invoice. If we receive payment in full on or before the due date we will allow a discount of 5% except where we have quoted a special net price. If payment is not received in full on or before the due date we shall be entitled in addition to the invoice price to:

- (i) payment of a sum equal to any increase in the copper price supplement applicable to the particular goods sold between the date of receipt of order and the date of receipt of payment in full; and
- (ii) interest on any part of the invoice price unpaid after the due date at the rate of 3% per annum over the base rate for the time being of Midland Bank plc.

## 5. TIME

We give estimates of delivery dates in good faith and time of delivery is not nor shall be made of the essence of any contract nor shall we be liable for any loss or damage occasioned by delay in delivery.

## 6. DELIVERY

We deliver free normally by our own vehicles within 25 miles of any of our manufacturing depots. Delivery to any place more than 25 miles from one of our manufacturing depots is subject to our quoted delivery charges. We reserve the right to make delivery of goods contained in one order by more than one consignment and at different times. Where a period is agreed for delivery and such period is not extended by our Agreement, the Purchaser shall take delivery within that period. If the Purchaser fails to take delivery, we shall be entitled at the Purchaser's risk and expense to store the goods at the Purchaser's premises or elsewhere and to demand payment as if they had been despatched. Offloading at point of delivery shall be the responsibility of and be undertaken by the Purchaser.

## 7. SHORTAGES OR DAMAGE

Goods must be inspected before signature of delivery note and any damage, shortage or discrepancy noted on the delivery note and the goods returned on the same vehicle. The buyer must also give us immediate written notice of the damage, shortage or discrepancy so that we may prompt investigation.

## 8. RETURN OF GOODS

Goods may not be returned to the Company except by prior written permission of an authorised officer of the Company and such return shall be subject to payment by the Purchaser of handling and re-stocking charges, transport and all other costs incurred by the Company.

## 9. COMPANY LIABILITY

All our goods are made of the best materials from reputable manufacturers and where stated are manufactured to the appropriate British Standard. Complaints must be given to us immediately, before any action is taken, as responsibility cannot be accepted if repairs or renewals are attempted on site without our written authority.

Where we agree to rectify any defect, we reserve the right to undertake the work on our own premises. Provided that our product has been installed in accordance with any instructions for installation any relevant codes of practice and in accordance with the bye-laws and requirements obtaining in any particular area we give the following warranties:

### (1) Domestic and Commercial Open Vented Cylinders and Tanks.

If the copper cylinder or tank or any integral pipework proves to be defective either in materials or workmanship, we will either repair or supply replacement at our option with the closest substitute in the case of any obsolete product to any address in Great Britain.

- (a) free of all charge during the first year after delivery by us.
- (b) thereafter at a charge of one-tenth of the then current list price and any copper price supplement and delivery charge during the second year after delivery by us and increasing by a further one-tenth on the second and subsequent anniversary of delivery by us.

**AND FURTHER** we will meet the contractors/installers reasonable costs in removing and replacing any defective Open Vented Copper Cylinder or Tank with defective integral pipework as follows:

- (i) in the case of vessels of less than 80 imperial gallons capacity up to a maximum of one-half of the extent of our liability in regard to the replacement product expressed in (1) (a) and (b) above
- ii) in the case of vessels larger than 79 imperial gallons capacity up to a maximum of one-quarter of the extent of our liability in regard to the replacement product as expressed in paragraphs (1) (a) and (b) above.

### (2) Domestic Mains Fed Products

If the copper storage vessel itself or any integral pipework as part of the storage vessel assembly proves to be defective either in materials or workmanship, we reserve the right to either repair or supply replacements or the closest possible substitute in the case of any obsolete product and will collect and deliver to any address in England, Wales and Scotland (excluding all Scottish Islands).

(a) free of all charge during the first year after delivery by us.

(b) thereafter at a charge of one-fifth of the then current list price or any copper price supplement and delivery charge during the second year after delivery by us increasing by a further one-fifth on the second and subsequent anniversary of delivery by us.

**AND FURTHER** we will meet the contractors/installers reasonable costs in removing and replacing any defective copper storage vessel or storage vessel with defective integral pipework from the Domestic Mains Pressure Range of products up to a maximum of one-third of the extent of our liability in regard to the replacement product expressed in (2) (a) and (b) above.

(3) Components of our products other than Storage Vessels and Integral Pipework. We will either extend to the purchaser the same terms of warranty as we are given by the manufacturer of the component or if the manufacturer does not give any warranty, replace free of charge any component which becomes defective within twelve months after the date of the delivery by us and is returned to us at the purchaser's expense but we shall not meet the cost of removal or shipping or return of the component or any other cost charges or damages incurred by the purchaser.

(4) In the case of the Gulfstream range of products any heat generator found to be defective and admitted to be such by us either as regards materials or workmanship within 12 months from date of installation or 18 months from date of manufacture whichever is the sooner, will be repaired or replaced at our option. **AND FURTHER** we will meet the contractors/installers reasonable costs in removing and replacing any defective heat generator up to a maximum of one-third of the extent of our liability in regard to the replacement product.

(5) In the case of goods manufactured solely in accordance with our specification and designs and in respect of any installation work carried out by or on our behalf, our entire liability and the purchaser's sole remedies (subject to (1-4) above) and shall be as follows:

(a) we accept liability for death or personal injury to the extent that it results from our negligence that of our employees agents or subcontractors.

(b) subject to paragraph (d) below, we accept liability for direct physical damage to tangible property to the extent that such damage is caused by our negligence that of our employees agents or subcontractors.

(c) our total liability to the purchaser over and above any liability to replace under (1 - 4) above (whether in contract or in tort including negligence) in respect of any one cause of loss or damage claimed to result from any breach of our obligations hereunder, shall be limited to actual money damages which shall not exceed £20,000 provided that such monetary limit shall not apply to any liability on the part of ourselves referred to in paragraph (a) above.

(d) except as provided in paragraph (a) above but otherwise notwithstanding any provision herein contained in no event shall we be liable for the following loss or damage howsoever caused and even if foreseeable by us or in our contemplation :-

(i) economic loss which shall include loss of profits, business revenue, goodwill or anticipated savings.

(ii) damages in respect of special indirect or consequential loss or damage (other than death, personal injury and damage to tangible property).

(iii) any claim made against the purchaser by any other party

(save as expressly provided in paragraph (b) above).

(e) except in respect of our liability referred to in paragraph (a) above no claim may be made or action brought (whether in contract or in tort including negligence) by the purchaser in respect of any goods supplied by us more than one year after the date of the invoice for the relevant goods.

(f) nothing in these Conditions shall confer on the purchaser any rights or remedies to which the purchaser would not otherwise be legally entitled.

(6) Notwithstanding any other provision contained herein the Purchaser's hereby agree to fully indemnify us against any damages losses costs claims or expenses incurred by us in respect of any claim brought against us by any third party for :-

(a) any loss injury or damage wholly or partly caused by any goods supplied by us or their use.

(b) any loss injury or damage wholly or partly caused by the defective installation or sub-standard workmanship or materials used in the installation of any goods supplied by us.

(c) any loss injury or damage in any way connected with the performance of this contract.

**PROVIDED** that this paragraph (6) will not require the Purchaser to indemnify us against any liability for our own acts of negligence or those of our employees agents or sub-contractors.

**FURTHER** in the case of goods supplied by us which are re-sold to and installed by a third party by the Purchaser it will be the sole responsibility of the Purchaser to test the goods immediately after their installation to ensure that inter alia they are correctly installed and are in proper working order, and are not likely to cause any loss injury or damage to any person or property.

#### **10. VARIATION OF WARRANTY AND EXCLUSION**

Should our warranty and exclusion be unacceptable we are prepared to negotiate for variation in their terms but only on the basis of an increase in the price to allow for any additional liability or risk which may result from the variation.

Purchasers are advised to insure against any risk or liability which they may incur and which is not covered by our warranty.

#### **11. RISK AND RETENTION OF TITLE**

(a) goods supplied by us shall be at the Purchaser's risk immediately upon delivery to the Purchaser or into custody on the Purchaser's behalf or to the Purchaser's Order. The Purchaser shall effect adequate insurance of the goods against all risks to the full invoice value of the goods, such insurance to be effective from the time of delivery until property in the goods shall pass to the Purchaser as hereinafter provided.

(b) property in the goods supplied hereunder will pass to the Purchaser when full payment has been made by the Purchaser to us for :-

(i) the goods of the subject of this contract.

(ii) all other goods the subject to of any other contract between the Purchaser and us which, at the time of payment of the full price of the goods sold under this contract, have been delivered to the Purchaser but not paid for in full.

(c) until property in the goods supplied hereunder passes to the Purchaser in accordance with paragraph (2) above.

(i) the Purchaser shall hold the goods in a fiduciary capacity for us and shall store the same separately from any other goods in the Purchaser's possession and in a manner which enables them to be identified as our goods.

(ii) the Purchaser shall immediately return the goods to us should our authorised representative so request. All the necessary incidents associated with a fiduciary relationship shall apply.

(d) the Purchaser's right to possess the goods shall cease forthwith upon the happening of any of the following events, namely :-

(i) if the Purchaser fails to make payment in full for the goods within the time stipulated in clause 4 hereof.

(ii) if the Purchaser, not being a company, commits any act of bankruptcy, makes a proposal to his or her creditors for a compromise or does anything which would entitle a petition for a Bankruptcy Order to be presented.

(iii) if the Purchaser, being a company, does anything or fails to do anything which would entitle an administrator or an administrative receiver or a receiver to take possession of any assets or which would entitle any person to present a petition for winding up or to apply for an administration order.

(e) the Purchaser hereby grants to us an irrevocable licence to enter at any time any vehicle or premises owned or occupied by the Purchaser or in the possession of the Purchaser for the purposes of repossessing and recovering any such goods the property in which has remained in us under paragraph (2) above. We shall not be responsible for and the Purchaser will indemnify us against liability in respect of damage caused to any vehicle or premises in such repossession and removal being damaged which it was not reasonably practicable to avoid.

(f) notwithstanding paragraph (3) hereof and subject to paragraph (7) hereof, the Purchaser shall be permitted to sell the goods to third parties in the normal course of business. In this respect the Purchaser shall act in the capacity of our commission agent and the proceeds of such sale :-

(i) shall be held in trust for us in a manner which enables such proceeds to be identified as such, and :

(ii) shall not be mixed with other monies nor paid into an overdrawn bank account.

We, as principal, shall remunerate the Purchaser as commission agent a commission depending upon the surplus which the Purchaser can obtain over and above the sum, stipulated in this contract of supply which will satisfy us.

(g) in the event that the Purchaser shall sell any of the goods pursuant to clause (6) hereof, the Purchaser shall forthwith inform us in writing of such sale and of the identity and address of the third party to whom the goods have been sold.

(h) if, before property in the goods passes to the Purchaser under paragraph (2) above the goods are or become affixed to any land or building owned by the Purchaser it is hereby agreed and declared that such affixation shall not have the effect of passing property in the goods to the Purchaser. Furthermore if, before property in the goods shall pass to the Purchaser under paragraph (2) hereof, the goods are or become affixed to any land or building (whether or not owned by the Purchaser), the Purchaser shall:-

(i) ensure that the goods are capable of being removed without material injury to such land or building.

(ii) take all necessary steps to prevent title to the goods from passing to the landlord of such land or building.

(iii) forthwith inform us in writing of such affixation and of the address of the land or building concerned.

The Purchaser warrants to repair and make good any damage caused by the affixation of the goods to or their removal from any land or building and to indemnify us against all loss damage or liability we may incur or sustain as a result of affixation or removal.

(i) in the event that, before property in the goods has passed to the Purchaser under paragraph (2) hereof, the goods or any of them are lost, stolen, damaged or destroyed :-

(i) the Purchaser shall forthwith inform us in writing of the fact and circumstances of such loss, theft, damage or destruction.

(ii) the Purchaser shall assign to us the benefit of any insurance claim in respect of the goods so lost, stolen, damaged or destroyed.

#### **12. NON-PAYMENT**

If the Purchaser shall fail to make full payment for the goods supplied hereunder within the time stipulated in clause 4 hereof or be in default of payment for any other reason then, without prejudice to any of our other rights hereunder, we shall be entitled to stop all deliveries of goods and materials to the Purchaser, including deliveries or further deliveries of goods under this contract. In addition we shall be entitled to terminate all outstanding orders.

#### **13. RISK**

All goods sold by us shall be at the sole risk of the Purchaser from the date of despatch by us of the invoice for their price.

#### **14. VALUE ADDED TAX**

All prices quoted are exclusive of Value Added Tax which will be charged at the rate ruling at the date of despatch of invoice.

#### **15. TRADE SALES ONLY**

We are only prepared to deal with those who are not consumers within the terms of the Unfair Contract Terms Act 1977, the Sale of Goods Act 1979 and the Supply of Goods and Services Act 1982. Accordingly any person who purchases from us shall be deemed to have represented that he is not a consumer by so purchasing.

#### **16. JURISDICTION**

The agreement is subject to English/Scots law and any dispute arising hereunder shall be settled in accordance therewith dependent upon the location.











