

INSTALLATION AND SERVICING

Flexicom

18sx

G.C. No. 41-315-72

**High Efficiency
Condensing System
Boilers**



Glow-worm, Nottingham Road, Belper, Derbyshire. DE56 1JT

www.glow-worm.co.uk

Guarantee Registration

Thank you for installing a new Glow-worm appliance in your home.

Glow-worm appliances are manufactured to the very highest standard so we are pleased to offer our customers a Comprehensive Guarantee.

This product is guaranteed for 24 months from the date of installation or 30 months from the date of manufacture, whichever is the shorter, for parts. In addition this product is guaranteed for 12 months from the date of installation or 18 months from the date of manufacture, whichever is the shorter, for labour.

The second year of the parts guarantee, from the beginning of the 13th month onwards after installation or manufacture, is conditional upon the boiler having been serviced by a CORGI registered gas installer,

in accordance with the manufacturer's recommendations. We strongly recommend regular servicing of your gas appliance, but where the condition is not met, any chargeable spare parts or components issued within the applicable guarantee period still benefit from a 12 month warranty from the date of issue by the manufacturer.

We recommend you complete and return as soon as possible your guarantee registration card. If your guarantee registration card is missing you can obtain a copy or record your registration by telephoning the Glow-worm Customer Service number 01773 828100.

Customer Service:

01773 828100

Technical Helpline:

01773 828300

General and Sales enquiries:

Tel. 01773 824639

Fax: 01773 820569

**To register your Glow-worm appliance
call:**

0800 0732142



The code of practice for the installation,
commissioning & servicing of gas central heating

The instructions consist of two parts, Installation and Servicing Instructions. The instructions are an integral part of the appliance and must, to comply with the current issue of the Gas Safety (Installation and Use) Regulations, be handed to the user on completion of the installation.

CONTENTS	DESCRIPTION	SECTION	PAGE
INTRODUCTION	Warnings		4
	Important Information		3
	General Information		5
	Appliance Safety Devices		6
	Maintenance and Servicing		6
INSTALLATION INSTRUCTIONS	Technical Information	1	7
	Boiler Location and Ventilation	2	9
	Flue Options and Terminal Clearances	3	10
	Heating System	4	12
	Domestic Hot Water System	5	14
	Installation Preparation	6	15
	Gas/Water & Appliance Connection	7	18
	Safety Discharge Valve and Condensate Connection	8	20
	Flue Preparation and Installation	9	22
	Electrical Connection	10	35
	Commissioning	11	37
	Servicing	12	39
	Fault Finding	13	43
	Replacement of Parts	14	49
	Spare Parts	15	56
Manual Handling	16	57	

WARNINGS

Gas Leak or Fault

Turn off the gas emergency control valve immediately. Eliminate all sources of ignition, i.e. smoking, blowlamps, hot air guns etc. Do not operate electrical lights or switches either on or off. Open all doors and windows, ventilate the area.

Sheet Metal Parts

This boiler contains metal parts (components) and care should be taken when handling and cleaning, with particular regard to edges.

Sealed Components

Under no circumstances must the User interfere with or adjust sealed parts.

Important Information

Gas Category

This boiler is for use only on G20 natural gas.

Gas Safety (Installation and Use) Regulations

In your own interests and that of safety, it is the Law that ALL gas appliances are installed by a competent person in accordance with the current issue of the above regulations.

Testing and Certification

This boiler is tested and certificated for safety and performance. It is, therefore, important that no alteration is made to the boiler, without permission, in writing, by Glow-worm.

Any alteration not approved by Glow-worm, could invalidate the certification, boiler warranty and may also infringe the current issue of the statutory requirements.

CE Mark

This boiler meets the requirements of Statutory Instrument, No. 3083 The Boiler (Efficiency) Regulations, and therefore is deemed to meet the requirements of Directive 92/42/EEC on the efficiency requirements for new hot water boilers fired with liquid or gaseous fuels.

Type test for purposes of Regulation 5 certified by: Notified body 0087.

Product/production certified by: Notified body 0086.

The CE mark on this appliance shows compliance with:

1. Directive 90/396/EEC on the approximation of the laws of the Member States relating to appliances burning gaseous fuels.
2. Directive 73/23/EEC on the harmonisation of the Laws of the Member States relating to electrical equipment designed for use within certain voltage limits.
3. Directive 89/336/EEC on the approximation of the Laws of the Member States relating to electromagnetic compatibility.

Control of Substances Hazardous to Health

Under Section 6 of The Health and Safety at Work Act 1974, we are required to provide information on substances hazardous to health.

The adhesives and sealants used in this appliance are cured and give no known hazard in this state.

Electrical Supply

The boiler must be earthed.

All system components shall be of an approved type and all wiring to current I.E.E. wiring regulations.

External wiring must be correctly earthed, polarised and in accordance with the relevant standards.

In GB this is BS 7871.

In IE this is the current edition of I.S.813 "Domestic Gas Installations".

The boiler must be connected to a permanent 230V ac, 50Hz supply.

Connection of the whole electrical system of the boiler, including any heating controls, to the electrical supply must be through one common isolator and must be fused 3 Amp maximum.

Isolation should be by a double pole switched fused spur box, with a minimum gap of 3mm for both poles. The fused spur box should be readily accessible and preferably adjacent to the appliance. It should be identified as to its use.

Alternatively connection can be made through an unswitched shuttered socket and 3A fused 3-pin plug both to the current issue of BS 1363, provided they are not used in a room containing a bath or shower.

Wiring to the boiler must be PVC 85°C insulated cable, not less than 0.75mm² (24/0.20mm).

IMPORTANT NOTE

ALL electrical connections to the boiler must be permanently fixed to a wall or a sturdy support feature in a tidy manner.

General Information

General Note

This boiler is designed for use as part of a sealed water central heating system with fully pumped circulation. The pump, expansion vessel and associated safety devices are all fitted within the boiler.

Once the controls are set the boiler operates automatically. Please read these instructions and follow them carefully for the correct installation and economical use of your boiler.

Water Treatment

In the case of an existing system, it is ESSENTIAL that prior to installing the new boiler the system is thoroughly flushed. For optimum performance after installation of a new system, the boiler and its associated central heating system should also be flushed. Flushing should be carried out in accordance with BS7593: 1992 using a cleanser such as Sentinel X300 or X400, Fernox Restorer or Salamander corrosion guard cleaner.

For long-term corrosion protection, after flushing, a suitable inhibitor should be used, refer to the current issue of BS 5449 and BS 7593 on the use of inhibitors in central heating systems. Examples are Sentinel X100, Fernox Protector or Salamander corrosion guard inhibitor.

Compartment or Cupboard Installations

If the boiler is fitted into a compartment or cupboard it does not require ventilation openings.

Do not use the compartment or cupboard for storage.

Clearances

If fixtures are positioned close to the boiler, space must be left as shown in diagram 2.1.

Condensate Drain

The condensate drain, see diagram 8.2, must not be modified or blocked.

Plumbing from flue terminal

Like all condensing boilers this appliance will produce a plume of condensation from the flue terminal in cool weather. This is due to the high efficiency and hence low flue gas temperature of the boiler. It is normal and not a fault indication.

Electrical Supply

If the mains electricity and gas are to be turned off for any long periods during severe weather, it is recommended that the whole system, including the boiler, should be drained to avoid the risk of freezing. Make sure that, if fitted, the immersion heater in the cylinder is switched off.

NOTE: Contact your installation/servicing company as draining, refilling and pressurising **MUST** be carried out by a **competent person**.

Manual Handling

IMPORTANT: With regards to the "Manual Handling Operations, 1992 Regulations", the appliance exceeds the recommended weight for a one man lift.

Appliance Safety Devices

Electrical Supply Failure

The boiler will not work without an electrical supply. Normal operation of the boiler should resume when the electrical supply is restored. Reset any external controls, to resume normal operation of the central heating. If the boiler does not resume normal operation press the reset button. If the boiler does not resume normal operation after this call your Installation/Service company.

Overheating safety

In the event of the boiler overheating the safety devices will cause a safety shutdown. If this happens, press the reset button.

Safety Discharge Valve

A safety discharge valve and discharge pipe is fitted to the boiler. This valve must not be touched. Should there be any discharge from the pipe, isolate the boiler electrical supply and call your installer or Glow-worm's own service organisation using the telephone number on the inside front cover of this booklet.

Frost protection

The appliance has a built in frost protection device that protects the boiler from freezing. With the gas and electric supplies ON and irrespective of any room thermostat setting, the frost protection device will operate the pump when the temperature of the boiler water falls below 8°C. A timer is used so that the temperature can be checked periodically. After 10 minutes the pump will be stopped if the temperature is higher than 10°C or has already reached 35°C. The burner will activate if the boiler temperature does not reach 10°C after 30 minutes or at any time if the temperature drops to 5°C. The burner will switch off when the temperature reaches 35°C.

Condensate Drain Blockage

As a safety feature the boiler will stop working if the condensate drain becomes blocked. During freezing conditions this may be due to the forming of ice in the condensate drain external to the house. Release an ice blockage by the use of warm cloths on the pipe. The boiler should then restart. Contact your installation/service company if the fault persists.

Maintenance and Servicing

Maintenance and Servicing

To ensure the continued efficient and safe operation of the appliance it is recommended that it is checked and serviced as necessary at regular intervals. The frequency of servicing will depend upon the particular installation conditions and usage. If this appliance is installed in a rented property there is a duty of care imposed on the owner of the property by the current issue of the Gas Safety (Installation and Use) Regulations, Section 35. Servicing/maintenance should be carried out by a **competent person** in accordance with the rules in force in the countries of destination. To obtain service, please call your installer or Glow-worm's own service organisation using the telephone number on the inside front cover of this literature. Please be advised that the 'Benchmark' logbook, located at centre of literature, should be completed by the installation engineer on completion of commissioning and servicing.

Spare Parts

Remember, when replacing a part on this appliance, use only spare parts that you can be assured conform to the safety and performance specification that we require. Do not use reconditioned or copy parts that have not been clearly authorised by Glow-worm. If a part is required contact Glow-worm's own service organisation using the telephone number on the inside front cover of this booklet. Please quote the name of the appliance, this information will be on the name badge on the front of the appliance. If in doubt seek advice from the local gas company or Glow-worm's own service organisation using the telephone number on the inside front cover of this booklet.

1 Technical Information

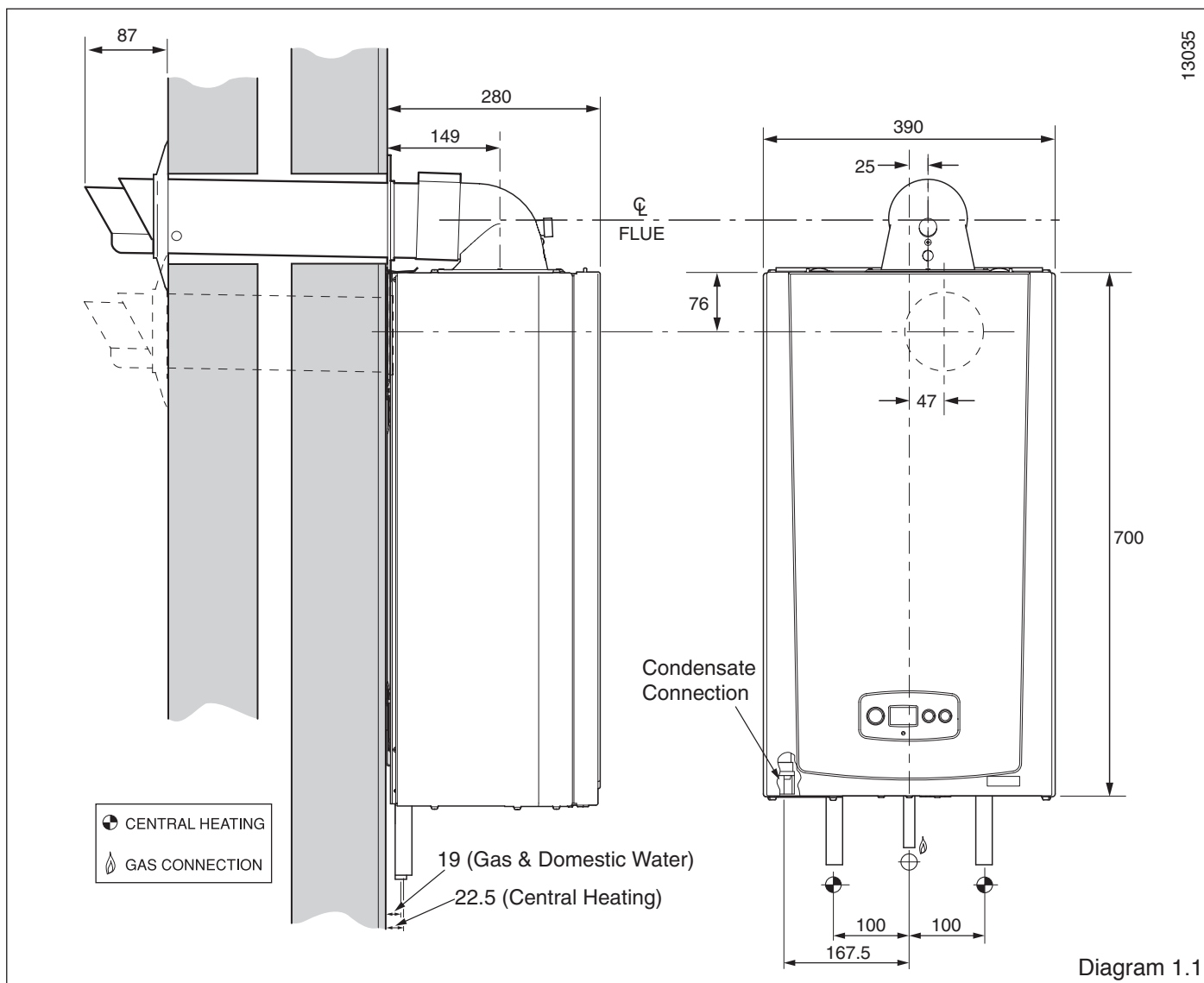

1.1 IMPORTANT NOTICE

The boiler is supplied in one carton, which includes the appliance packs, see diagram 5.1.

The flue is supplied separately.

This boiler is for use only on G20 natural gas.

Where no British Standards exists, materials and equipment should be fit for their purpose and of suitable quality and workmanship.

The installation of this boiler must be carried out by a **competent person** in accordance the rules in force in the countries of destination.

Manufacturer's instructions must not be taken as overriding statutory requirements.

1.2 Statutory Requirements

In GB the installation of the boiler must be carried out by a competent person as described in the following regulations:

The manufacturer's instructions supplied.

The Gas Safety (Installation and Use) Regulations.

The appropriate Buildings Regulations either The Building Regulations, The Building Regulations (Scotland), The Building Regulations (Northern Ireland).

The Water Fittings Regulations or Water byelaws in Scotland.

The Health and Safety at Work Act, Control of Substances Hazardous to Health (COSHH).

The Current I.E.E. Wiring Regulations.

Where no specific instructions are given, reference should be made to the relevant British Standard Code of Practice.

In IE, the installation must be carried out by a **competent person** and installed in accordance with the current edition of I.S.813 "Domestic Gas Installations", the current Building Regulations and reference should be made to the current ETCI rules for Electrical Installation.

In GB the following Codes of Practice apply:

BS4814, BS6798, BS5440 Part 1 and 2, BS5546 Part 1, BS5449, BS6891, BS6700, BS7074 Part 1 and 2, BS7593, BS7671.

In IE: I.S.813, BS5546, BS 5449, BS 7074, BS 7593.

Manufacturer's instructions must not be taken as overriding statutory requirements.

NOTE: For further information, see the current issue of the Building Regulations, approved document L1 (in the UK) and the references:

- 1) Central heating system specification (CheSS) and
- 2) Controls for domestic central heating system and hot water. BRECSU.

1 Technical Information

1.3 Gas Supply

The gas installation must be in accordance with the relevant standards.

In GB this is BS6891.

In IE this is the current edition of I.S.813 "Domestic Gas Installations".

The supply from the governed meter must be of adequate size to provide a steady inlet working pressure of 20mbar (8in wg) at the boiler.

On completion, test the gas installation for soundness using the pressure drop method and suitable leak detection fluid, purge in accordance with the above standard.

1.4 Technical Data

All dimensions are given in millimetres (except as noted).

See diagrams 1.1 and 1.2.

The data label is positioned on the base of the boiler.

1.5 Condensate Drain

A plastic drain pipe must be fitted to allow discharge of condensate to a drain.

Condensate should, if possible, be discharged into the internal household draining system. If this is not practical, discharge can be made externally into the household drainage system or a purpose designed soak away, see section 8.2 for more details.

1.6 Vertical Plumbing Kits

Should any combination of the domestic hot water, heating flow or return pipes come from above the boiler, an Upward Piping Kit is available to facilitate, part No. A2041500.

Contact Glow-worm for further details.

BOILER SPECIFICATION	18sx
Lift weight	36kg (79lb)
Total weight (installed)	41kg (90lb)
Gas connection Ø O.D.	15mm. copper
Heating and return connection Ø O.D.	22mm. copper
Condensate connection Ø I.D.	21.5mm. plastic
Safety valve discharge connection Ø O.D.	15mm. copper
Safety valve (preset)	3 bar (43/51bf/in ²)
Heating system minimum pressure	0.7bar (10.11bf/in ²)
Maximum flow temperature	82°
Expansion vessel capacity	8 litres (1.76 gallons)
Expansion vessel charge pressure	0.5bar (7,31bf/in ²)
Electrical supply	230V~50Hz
Electrical rating	180W fused 3A
IP classification	X4D
Internal fuse rating on main PCB	2A
Gas supply (governed metre only)	I ₂ H G20 natural gas
Inlet gas working pressure	20mbar
Burner % CO ₂ case on	9.3 nominal
Burner % CO ₂ case off	9.3 nominal
Approximate max. gas rate after 10 mins. from cold	1.93 m ³ /hr
	68.1 ft ³ /hr
Approximate min. gas rate after 10 mins. from cold	0.99 m ³ /hr
	35.1 ft ³ /hr
Heat input NETT Q = kW	18.2 max.
	9.4 min.
Heat output P = kW	18.0 max.
	9.3 min.
Flue type	C13, C33, C53
NOx	Class 5

13216

Diagram 1.2

2 Boiler Location and Ventilation

2.1 Location

This boiler is not suitable for outdoor installation.
This boiler may be installed in any room, although particular attention is drawn to the installation of a boiler in a room containing a bath or shower where reference must be made to the relevant requirements.
This boiler is suitable for installation in bathroom zones 2 and 3.
In GB this is the current I.E.E. WIRING REGULATIONS and BUILDING REGULATIONS.
In IE reference should be made to the current edition of I.S.813 "Domestic Gas Installations" and the current ETCI rules.

2.2 Clearances

The boiler should be positioned so that at least the minimum operational and servicing clearances are provided, see diagram 2.1.
Additional clearances may be beneficial around the boiler for installation and servicing.
For flue installations where external access is not practicable, consideration should be given for the space required to insert the flue internally, which may necessitate clearance larger than those specified in diagram 2.1.

2.3 Timber Frame Buildings

If the boiler is to be installed in a timber frame building it should be fitted in accordance with the Institute of Gas Engineers document IGE/UP/7/1998. If in doubt seek advice from the local gas undertaking or Glow-worm.

2.4 Room Ventilation

The boiler is room sealed so a permanent air vent is not required.

2.5 Cupboard or Compartment Ventilation

Due to the high efficiency and hence low casing temperature of this boiler, cupboard or compartment ventilation is not necessary.
Leave existing air vents.

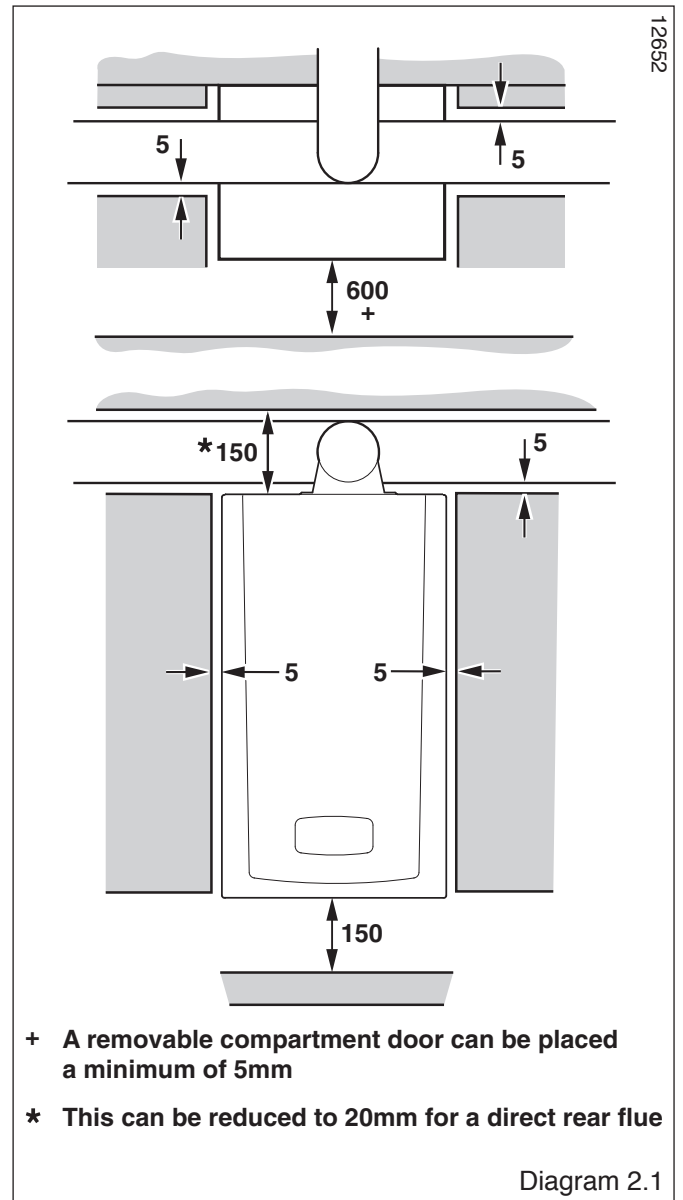
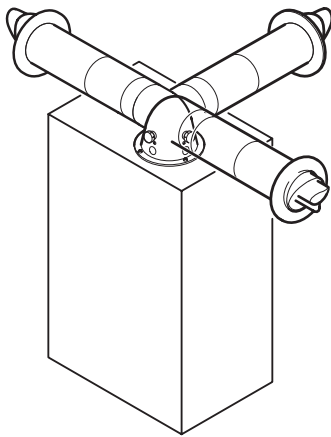
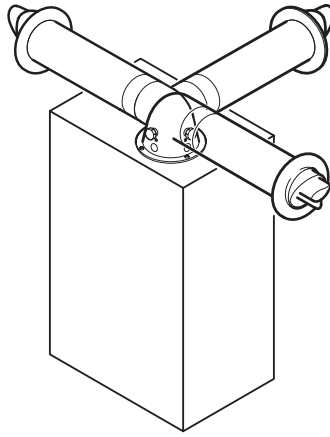

Diagram 2.1

3 Flue Options and Terminal Clearances



Top horizontal telescopic flue Ø60/100
Part No. A2043600



Top horizontal standard flue Ø60/100
Part No. A2043400

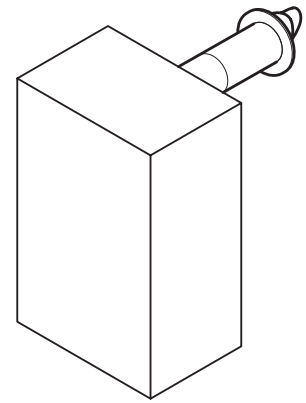

Rear telescopic flue Ø60/100
Part No. A2043500

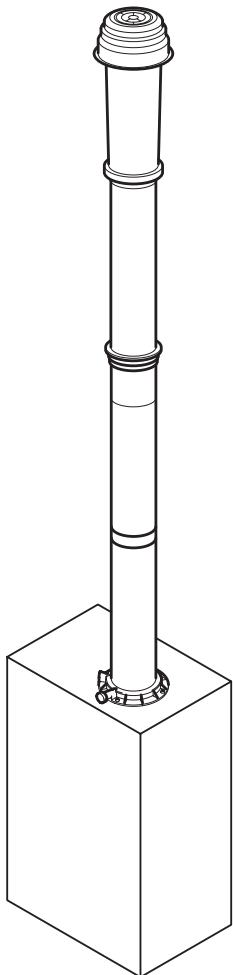

Vertical Flue
Vertical Flue Adapter, concentric flue Ø60/100
Part. No. A2024600
Vertical flue terminal kit, concentric flue Ø60/100
Part. No. 2000460480

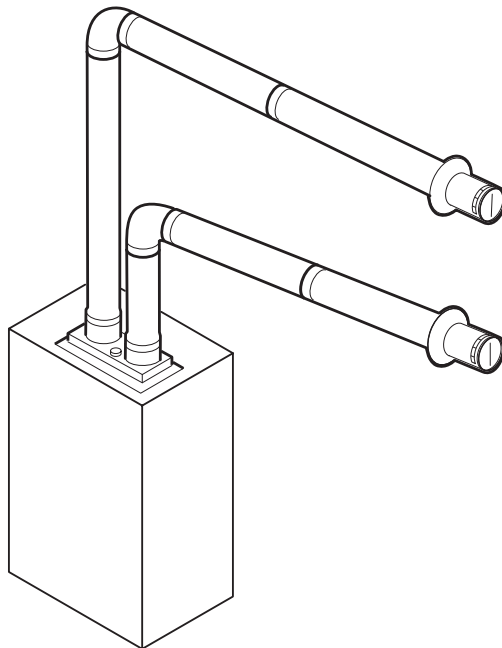

Twin Flue
Twin Flue Adapter, concentric flue Ø80
Part No. A2011000

Flue Accessories

Black Horizontal Terminal Kit, for use with
A2043500; A2043600; A2043400
Black Horizontal Terminal Kit,
concentric flue Ø60/100 - Part No. A2043700

Plume Management Kit, for use with
A2043500; A2043600; A2043400
Plume Management Kit, basic set, white,
concentric flue Ø60/100 - Part No. A2044100
1m extension, white - Part No. A2044300
87° elbow, white - Part No. A2044700
45° bend (2), white - Part No. A2044500
Plume Management Kit, basic set, black,
concentric flue Ø60/100 - Part No. A2044000
1m extension, black - Part No. A2044200
87° elbow, black - Part No. A2044600
45° bend (2), black - Part No. A2044400

Concentric Flue Ø60/100 accessories:
2 metre extension kit, concentric flue
Ø60/100 - Part No. 2000460483
1 metre extension kit, concentric flue
Ø60/100 - Part No. 2000460482
0.5 metre extension kit, concentric flue
Ø60/100 - Part No. 2000460481
Adjustable flue pipe 0-50mm kit,
concentric flue Ø60/100 - Part No. 2000460487
90° flue elbow pack,
concentric flue Ø60/100 - Part No. 2000460484
45° flue bend pack,
concentric flue Ø60/100 - Part No. 2000460485
Flue support clips (3),
concentric flue Ø60/100- Part No. A2043900

Additional accessories are available.
See Glow-worm "Flue Options Guide" for
configurations available.

Diagram 3.1

3 Flue Options and Terminal Clearances

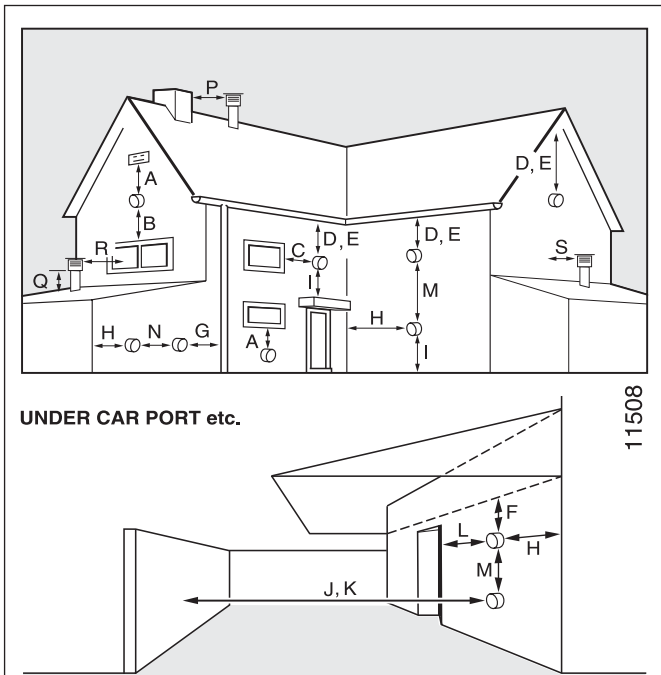

HORIZONTAL FLUES		
A	DIRECTLY BELOW AN OPENING, AIR BRICK, OPENING WINDOWS	300
B	ABOVE AN OPENING, AIR BRICK, OPENING WINDOWS	300
C	HORIZONTALLY TO AN OPENING, AIR BRICK, OPENING WINDOWS	300
D	BELOW GUTTER, DRAIN/SOIL PIPE	25
E	BELOW EAVES	25
F	BELOW A BALCONY OR CAR PORT	25
G	FROM VERTICAL DRAIN PIPES AND SOIL PIPES	25
H	FROM INTERNAL/EXTERNAL CORNERS	25
H*	TO A BOUNDARY ALONGSIDE THE TERMINAL	300
I	ABOVE ADJACENT GROUND OR BALCONY LEVEL	300
J*	FROM SURFACE OR A BOUNDARY FACING THE TERMINAL	600
K	FACING TERMINALS	1200
L	FROM OPENING (DOOR/WINDOW) IN CAR PORT INTO DWELLING	1200
M	VERTICAL FROM A TERMINAL	1500
N	HORIZONTALLY FROM A TERMINAL	300
VERTICAL FLUES		
P	FROM ANOTHER TERMINAL	600
Q	ABOVE ROOF LEVEL	300
R	FROM ADJACENT OPENING WINDOW	1000
S	FROM ADJACENT WALL TO FLUE	300

Diagram 3.2

3.1 Flue Options

There are various flue options to choose from as illustrated in diagram 3.1. The flue lengths and installation are described in section 9.

3.2 Flue Terminal Position

The minimum acceptable siting dimensions for the terminal from obstructions, other terminals and ventilation openings are shown in diagram 3.2. For Ireland the minimum distances for flue terminal positioning must be those detailed in I.S.813 "Domestic Gas Installations".

The terminal must be exposed to the external air, allowing free passage of air across it at all times.

Being a condensing boiler some plumbing may occur from the flue outlet. This should be taken into consideration when selecting the position for the terminal.

NOTE: If necessary it is permitted to increase the terminal protrusion through the outside wall to greater than the minimum dimension of 87mm but no more than 600mm, see diagram 1.1. Carports or similar extensions of a roof only, or a roof and one wall, require special consideration with respect to any openings, doors, vents or windows under the roof. Care is required to protect the roof if made of plastic sheeting. If the carport comprises of a roof and two or more walls, seek advice from the local gas supply company before installing the boiler.

H* and J* See diagram 3.2. These dimensions comply with the building regulations, but they may need to be increased to avoid wall staining and nuisance from plumbing depending on site conditions.

Plume Management Kit: Part No.A2044100 (white) or A2044000 (black) can be used to overcome many site issues.

3.3 Terminal Guard

A terminal guard is required if persons could come into contact with the terminal or the terminal could be subject to damage.

If a terminal guard is required, it must be positioned to provide minimum of 50mm clearance from any part of the terminal and be central over the terminal.

The guard should be similar to that shown in diagram 3.3.

A suitable guard is manufactured by: -
 Tower Flue Components
 Morley Rd.
 Tonbridge
 Kent
 TN9 1RA.
 Size: 280mm x 280mm x 270mm.

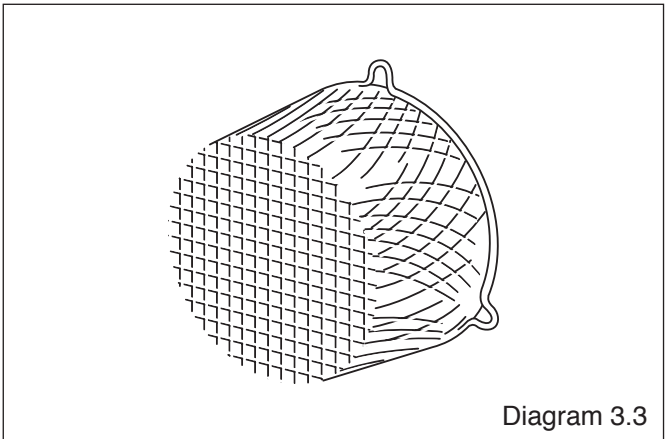

Diagram 3.3

4 Heating System

4.1 General

The boiler is for use only with sealed central heating systems. The safety valve is an integral part of the boiler and it cannot be adjusted. The digital read-out on the controls fascia indicates the system pressure when there is no demand. The circulation pump is integral with the boiler.

4.2 Expansion Vessel

The boiler has an integral expansion vessel with a capacity of 8 litres (1.76 gallons), with a change pressure of 0.5bar. **NOTE:** The expansion vessel volume depends on the total water system volume and the initial system design pressure. To check if an additional expansion vessel is required, an accurate calculation of vessel size is given in the current issue of BS5449 and BS7074 Part 1, for IE refer to the current edition of I.S.813 "Domestic Gas Installations".

4.3 Flow Rate

The flow rate through the boiler must not be allowed to fall below that given in diagram 1.2. The system can be fitted with a lockable balancing valve if necessary in the main flow or return pipes shown as valve "A" in diagram 4.1.

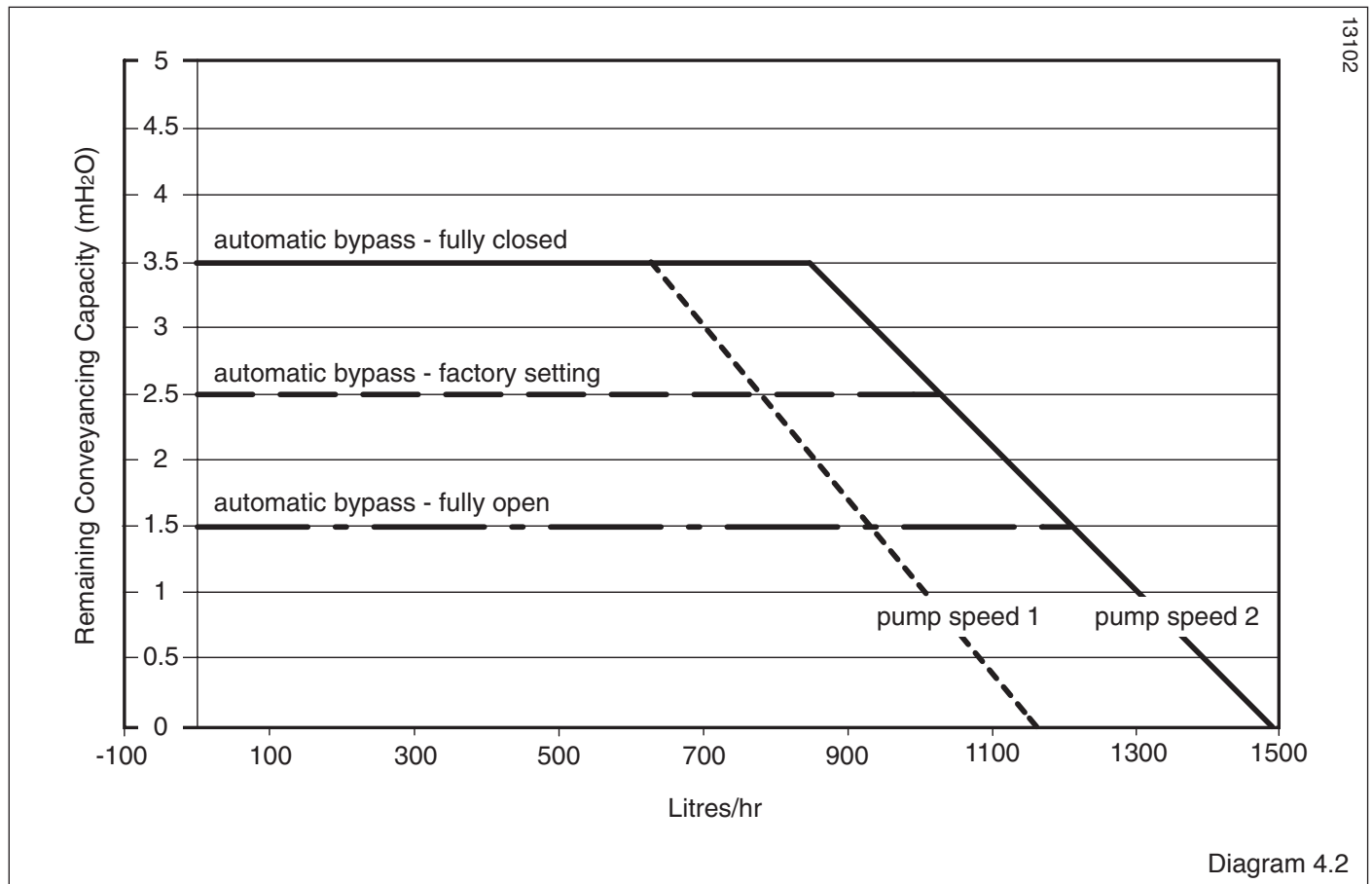
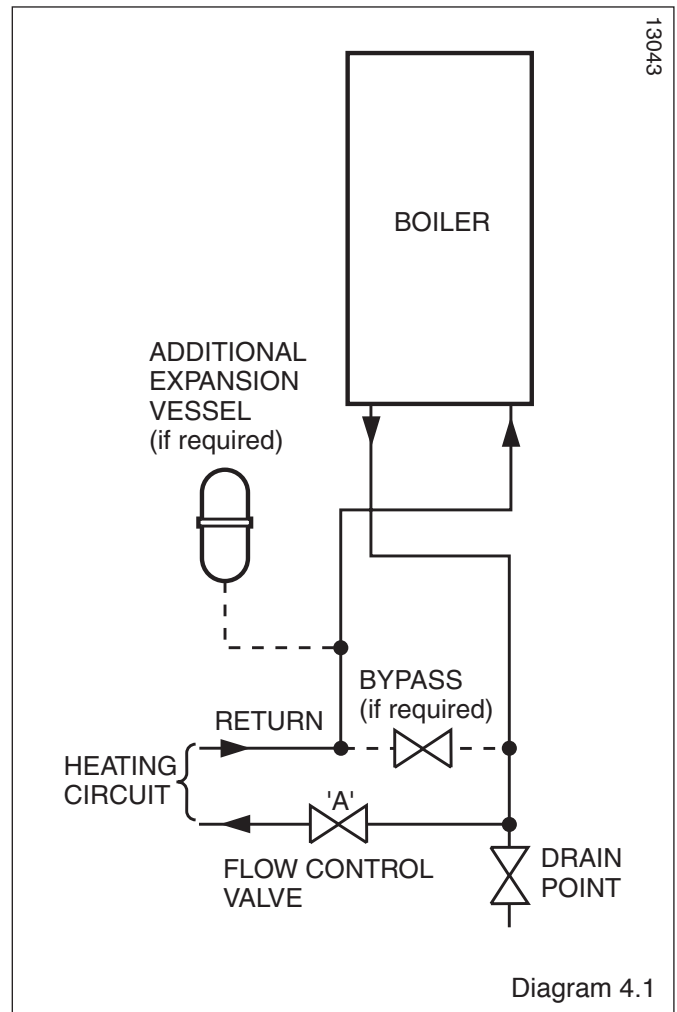

4 Heating System

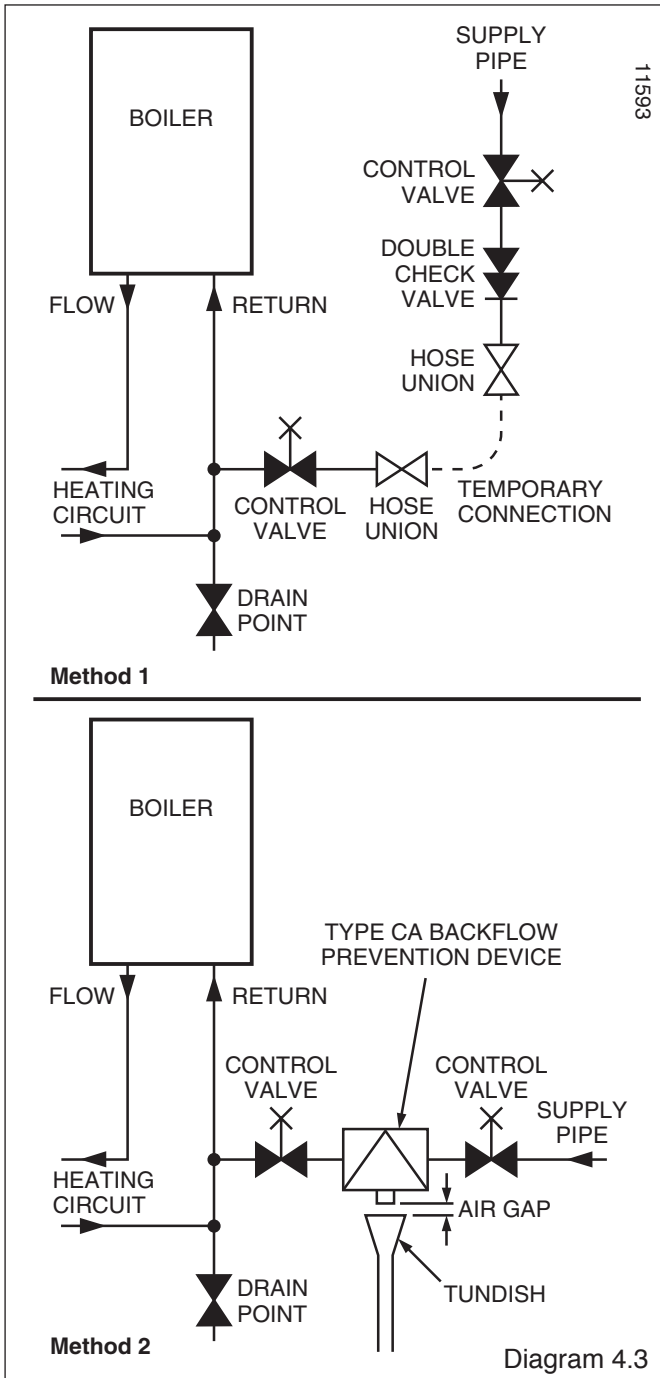

4.4 Bypass

The boiler is fitted with an adjustable automatic bypass. Diagram 4.2 shows the pump head remaining for the heating system depending on the bypass setting and the speed setting of the pump, see section 11 Commissioning. Ensure that under no circumstances does the flow rate drop below the figure specified, refer to table 3 and section 11.6. The installation of the boiler must comply with the requirements of the current issue of BS6798, in Ireland, refer also to the current edition of I.S.813 "Domestic Gas Installations". In GB it is necessary to comply with the Water Supply (Water Fittings) Regulations 1999 (for Scotland, the Water Byelaws 2000, Scotland). To comply with the Water regulations your attention is drawn to: The Water Regulations guide published by the Water Regulations Advisory Service (WRAS) gives full details of the requirements.

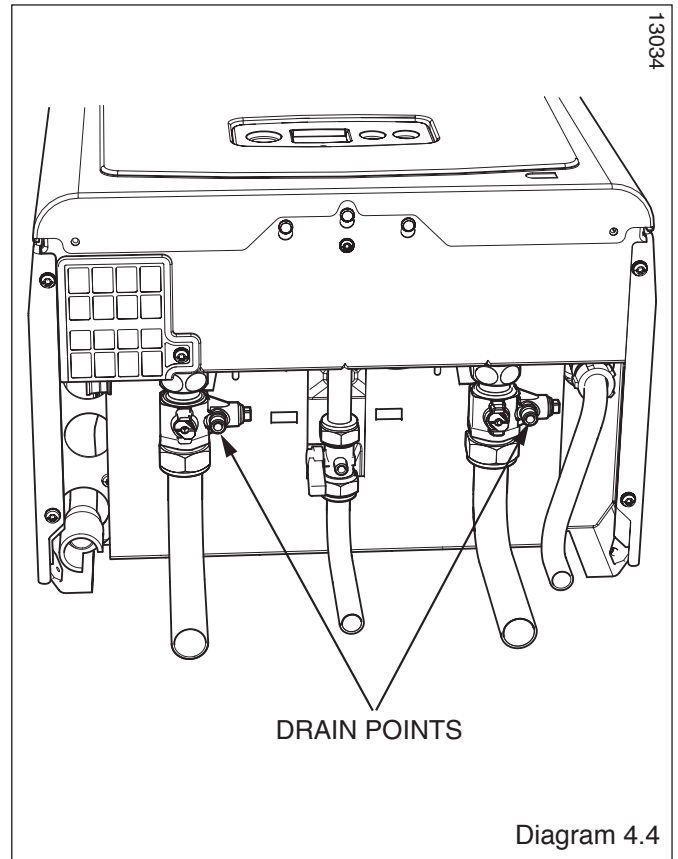

In IE the requirements given in the current edition of I.S.813 "Domestic Gas Installations" and the current Building Regulations must be followed.

4.5 Filling the Sealed System

Provision for filling the system at low level must be made, see diagram 4.3. There must be no permanent connection to the mains water supply, even through a non-return valve. **NOTE:** It is important that fittings used for connection to potable water comply with the water undertakings requirements.

4.6 Water Treatment

In the case of an existing system, it is ESSENTIAL that prior to installing the new boiler the system is thoroughly flushed. For optimum performance after installation of a new system, the boiler and its associated central heating system should also be flushed. Flushing should be carried out in accordance with BS7593: 1992 using a cleanser such as Sentinel X300 or X400, Fernox Restorer or Salamander corrosion guard cleaner. For long-term corrosion protection, after flushing, a suitable inhibitor should be used, refer to the current issue of BS 5449 and BS 7593 on the use of inhibitors in central heating systems. Examples are Sentinel X100 Fernox Protector or Salamander corrosion guard inhibitor.

4.7 Draining Points

Draining taps must be provided at the lowest points of the system, which will allow the entire system to be drained. Drain points for the appliance are provided at the positions shown in diagram 4.4.

5 Domestic Hot Water System

5.1 General

General - All domestic hot water circuits, connections, fittings must be in accordance with the relevant standards and water supply regulations.

For GB: Guidance G17 to G24 and recommendation R17 to R24 of the Water Regulations Guide.

For IE: The current edition of I.S.813 "Domestic Gas Installations".

The domestic water hot service must be in accordance with the current issue of BS5546, refer also to the current issue of BS6700.

5.2 Domestic Hot Water Cylinder

SINGLE FEED INDIRECT CYLINDERS ARE NOT SUITABLE AND SHOULD NOT BE USED.

The domestic hot water cylinder must be of the double feed indirect coil type. It must be suitable for working at a gauge pressure of 0.35bar above the safety valve setting.

6 Installation Preparation

6.1 Appliance Pack

IMPORTANT: With regards to the Health and Safety Manual Handling requirements, two persons shall be required to lift the appliance, refer to section 16 Manual Handling.

Please check the contents of packs as shown in diagram 6.1.

NOTE: The packs are located in the top polystyrene packing. The wall hanging bracket is located at the rear of the boiler, slide upwards to remove.

6.2 Wall Template

Take the wall template from the document pack located within the top polystyrene packing and place in the desired position on a flat wall, giving due consideration to boiler clearances, see section 2, and the flue you are fitting.

6.3 Flue Hole Cutting

External access flue installation can use a 105mm diameter core drill.

Internal access only flue installation will need a 125mm diameter core drill.

If flue extension pipes are to be used then a core drill size of 125mm is required. This will allow the extension pieces to slope at 44mm/metre (2.5°) towards the boiler.

Top horizontal flue - (standard and telescopic)

The standard horizontal flue is designed with an internal fall of 44mm/metre (2.5°) towards the boiler for disposal of condensate therefore the hole can be drilled horizontally. If the standard flue length alone is being used then the flue hole of diameter 105mm can be cut in the position marked on the wall template.

For standard side flues the horizontal flue centre line on the wall template should be extended to the side wall, and the vertical centre of the flue hole marked at 176mm from the back wall.

For extended side flues, the flue hole centre should be determined by extending the dashed inclined line on the template to the side wall. This dashed line is drawn at 44mm/metre (2.5°) rise from the boiler. Where this line reaches the side wall, a horizontal line should be marked. The vertical centre line of the flue should then be marked at 176mm from the back wall.

To allow for the flue passing through the wall at this angle a 125mm hole should be drilled irrespective of internal or external installation.

Remove the wall template whilst drilling the flue hole.

6.4 Rear flue - telescopic

The rear flue is designed with an internal fall of 44mm/metre towards the boiler for disposal of condensate therefore the hole can be drilled horizontally. For installations with external access, a 105mm diameter core drill can be used.

6 Installation Preparation

13037

Fixing Jig (pre-assembled)

- A - Jig Plate
- B - Plug
- C - Plug (gas)
- D - Clamping Spring
- E - Isolation Valve
- F - Isolation Valve
- G - Gas Service Cock

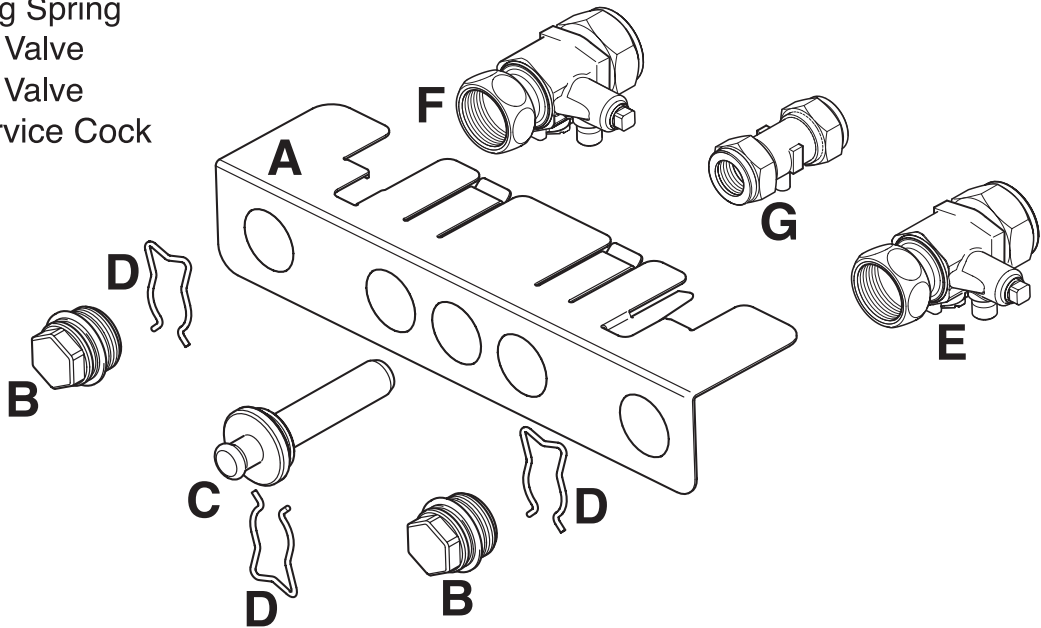

Pipe Pack

- A - Pipe (CH)
- B - Pipe (gas)
- C - Pipe (PRV)
- D - Plastic bag (not shown)
- E - Pipe pack sticker (not shown)

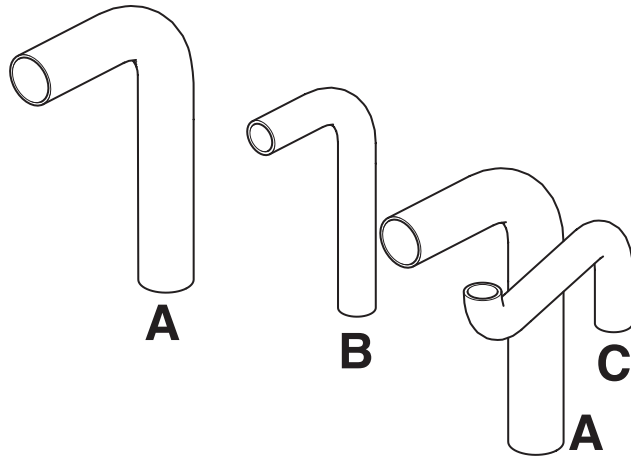

Loose Items Pack

- A - Sealing Washer
- B - Sealing Washer
- C - Union Nut
- D - Plastic Bag (not shown)

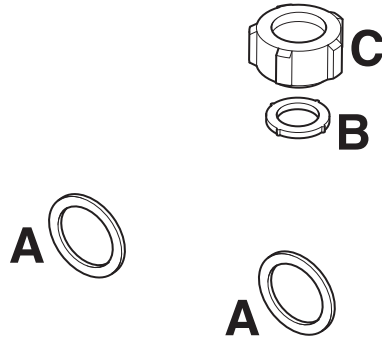

Documentation Pack (not illustrated)
 Wall Template, User Instructions, Installation
 and Servicing Instructions

Diagram 6.1

6 Installation Preparation

6.5 Wall Hanging Bracket Assembly

The Wall Hanging Bracket is supplied in the main boiler packaging at the rear of the boiler.

Reposition the wall template over the flue hole and mark the position of the fixing holes for the hanging bracket, see diagram 6.2.

NOTE: Due to the varied site conditions we do not supply fixings and advise that the installer should supply those which are suitable.

Drill fixing holes and insert suitable wall plugs.

Rear Flue only - If external access is not available the flue to be used should be assembled as described in section 9 and inserted through the hole in the wall before fitting the wall hanging bracket.

Fit the fixing jig support plate to the bottom of the wall hanging bracket, push down to locate. Mark, drill and plug at fixing points and secure the jig support plate, see diagram 6.3.

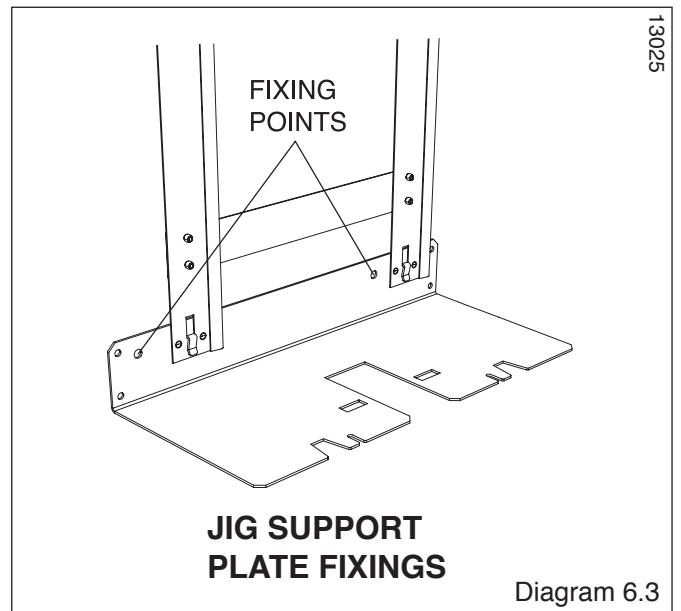
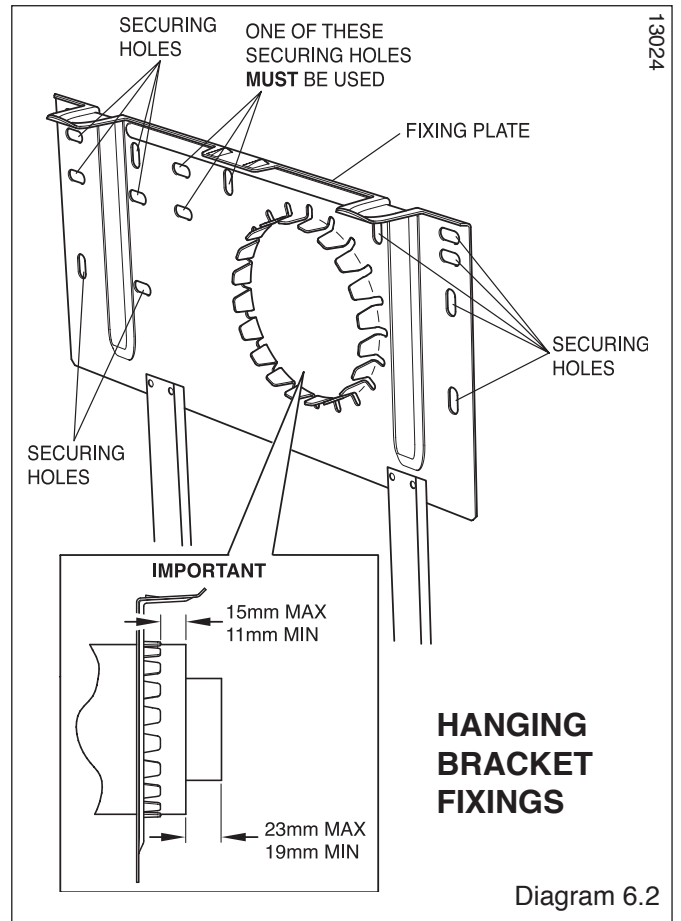

7 Gas / Water & Appliance Connection

7.1 System Connection

The Gas and Water systems can be connected and filled prior to installation of boiler.

All water and gas connections are on the fixing jig with the exception of the condense drain and safety discharge, the positions of these are shown on the wall template.

An Upward Piping Kit, part no. A2041500 should be used if the supplies come from above the boiler otherwise the pipes will have to be chased into the wall.

Fit the Central Heating Isolation Valve handles and secure with screws provided.

Fit the assembled Jig Plate to the Support Plate as shown in diagram 7.1.

Assemble the Gas Service Cock and position onto the plastic plug.

NOTE: Make sure the drain points are accessible, refer diagram 4.4.

Plumb system pipe work to the copper tails. Do not subject service cocks to heat.

There are flats on the body of the valves for locating a spanner to aid tightening to copper tails.

NOTE: At this stage alternative filling and pre-filling methods can be used, refer to section 11 Commissioning.

Prior to filling the water system ensure that the blanking plugs and isolation valves are secured.

Flush out the domestic hot water and the heating systems.

The whole of the gas installation, including the meter, should be inspected, tested for soundness and purged in accordance with the current issue of BS6891 and in IE the current edition of I.S.813 "Domestic Gas Installations".

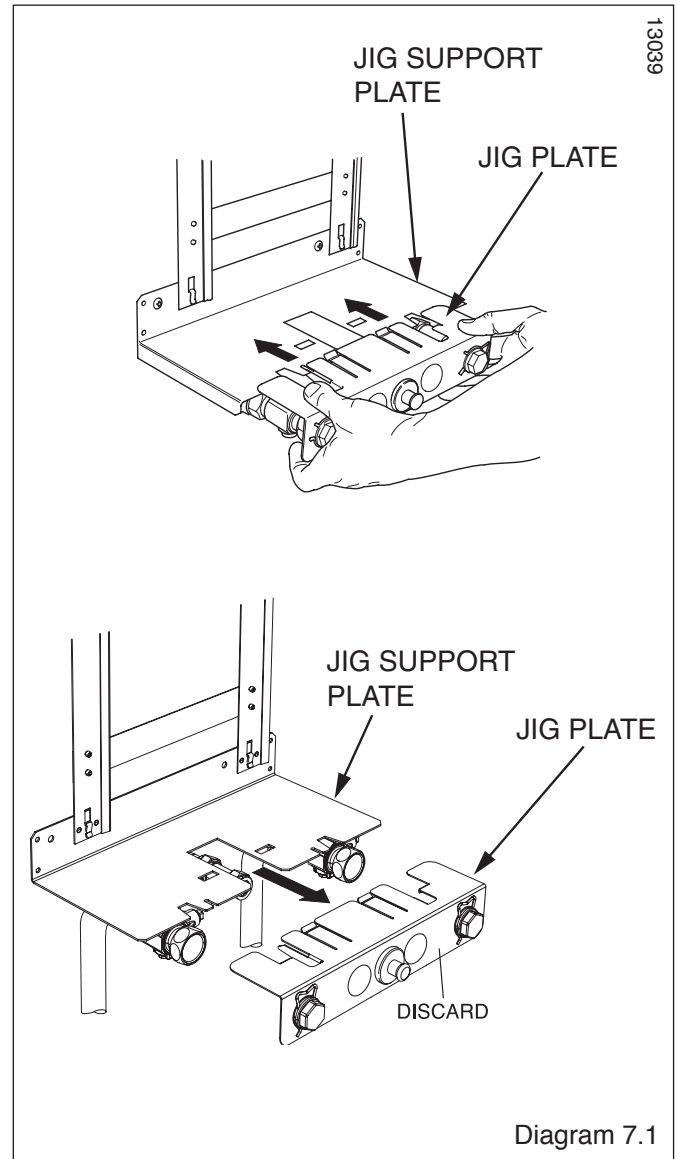

7 Gas / Water & Appliance Connection

7.2 Appliance Connection

IMPORTANT: With regards to the Manual Handling Operations, 1992 Regulations, the following lift operation exceeds the recommended weight for a one man lift, refer to section 16 Manual Handling.

Rear Flue only

This must be fitted before hanging the boiler, refer to Section 9.

NOTE: The appliance and jig (pre-filled) may contain a small amount of water, place a water container beneath the boiler connections.

Make sure the isolation valves are closed before disconnecting the blanking plugs and discarding the jig plate.

Position the sealing washers supplied in the Loose Items pack, as shown in diagram 7.2.

Lifting the boiler into position, lean the top of the boiler slightly to the wall and position just above the hanging bracket. Lower the boiler slowly push back and engage onto the hanging bracket making sure the boiler is located over the retaining bosses, see diagram 7.2.

Remove the protective caps.

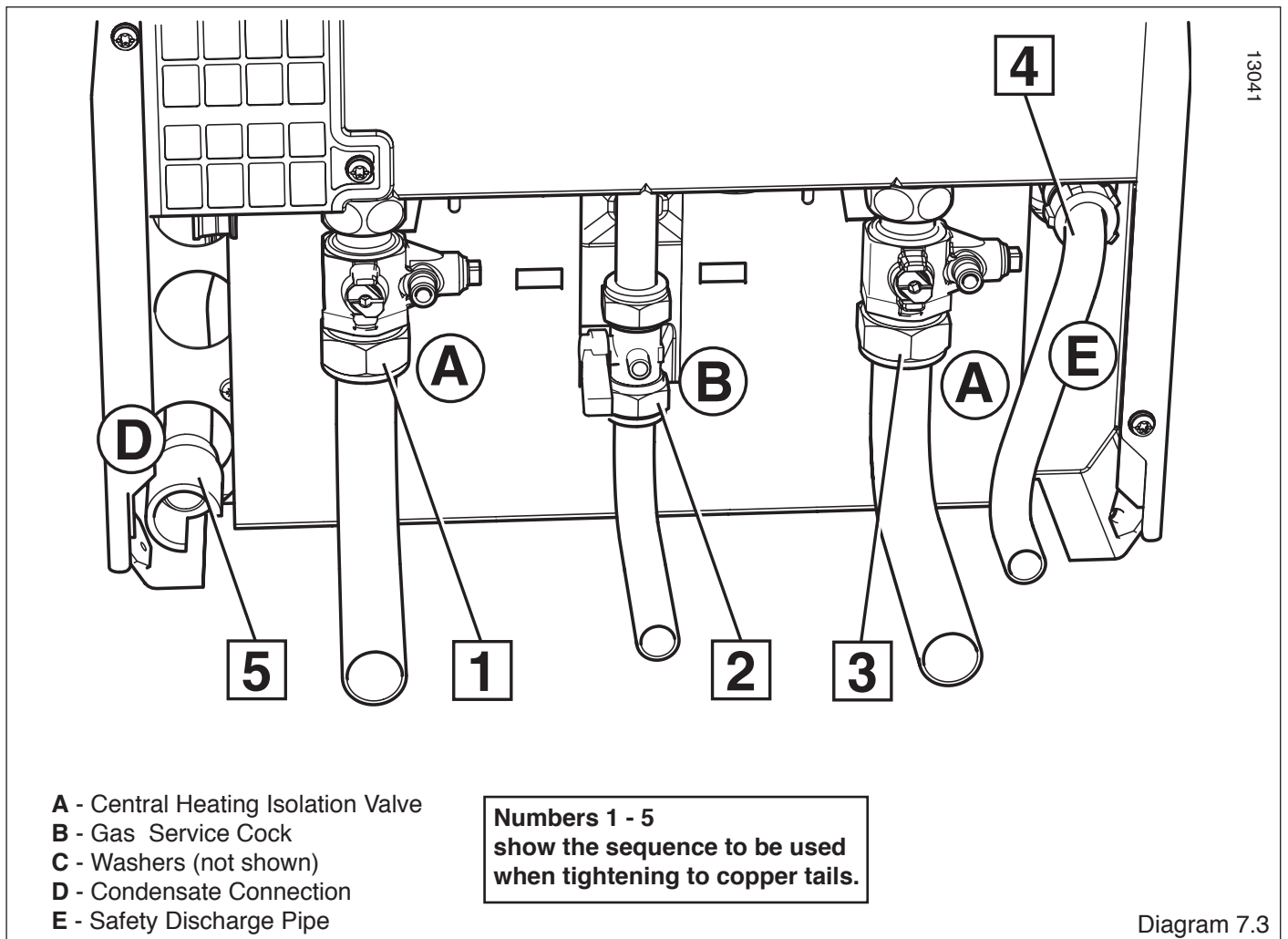
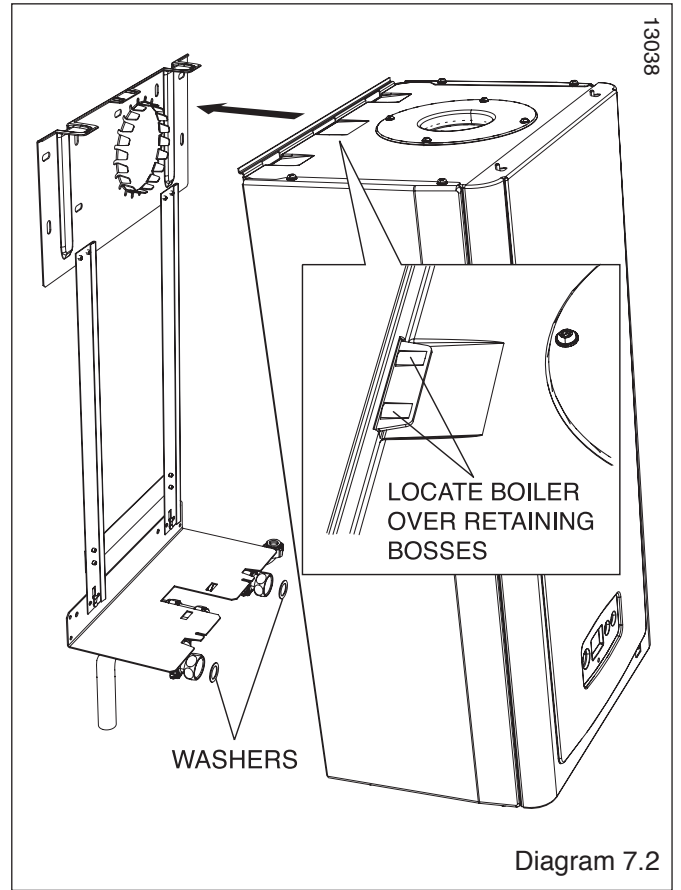

8 Safety Discharge Valve & Condensate Connections

8.1 Safety Discharge Valve

The pipe from the safety discharge valve must not discharge above an entrance, window or any type of public access area. Take the short safety discharge tube, union nut and seal, supplied loose in the boiler fittings pack and fit as shown in diagram 7.3.

This must be extended, using not less than 15mm o.d. pipe, to discharge, in a visible position, outside the building, facing downwards, preferably over a drain.

The pipe must have a continuous fall and be routed to a position so that any discharge of water, possibly boiling, or steam cannot create any danger to persons, damage to property or external electrical components and wiring.

To ease future servicing it is advisable to use a compression type fitting to extend the safety discharge valve tube.

8.2 Condensate Drain Connection

For condensate drain connection, see diagram 7.3. To discharge condensate to a drain, the drain pipe should have a fall of a least 44mm/metre (2.5°) away from the boiler.

Condensate should, if possible be discharged into the household internal drainage system. If this is not practicable, discharge can be allowed into the external household drains or a purpose designed soak away, refer to diagram 8.3.

It is recommended that any external condensate drain pipe is insulated and also preferably of 32mm diameter, to prevent freezing in adverse weather conditions.

The condensate is discharged periodically in 'slugs' by siphonic action.

It is not necessary to provide air breaks or extra traps in the discharge pipe as there is already a trap inside the boiler, see diagram 8.2. Fitting an extra trap may cause the boiler siphon to work incorrectly.

Refer to BS5546 or BS6798 for advice on disposal of boiler condensate.

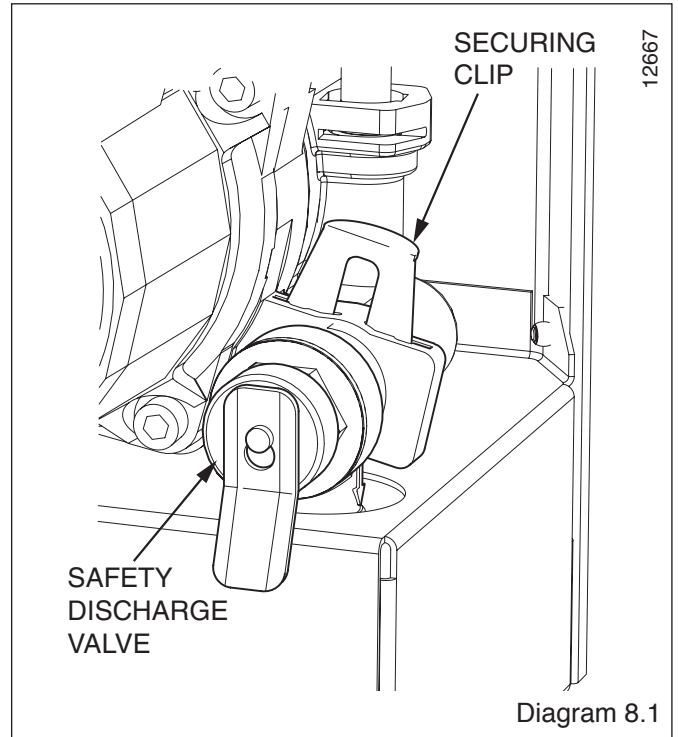

Diagram 8.1

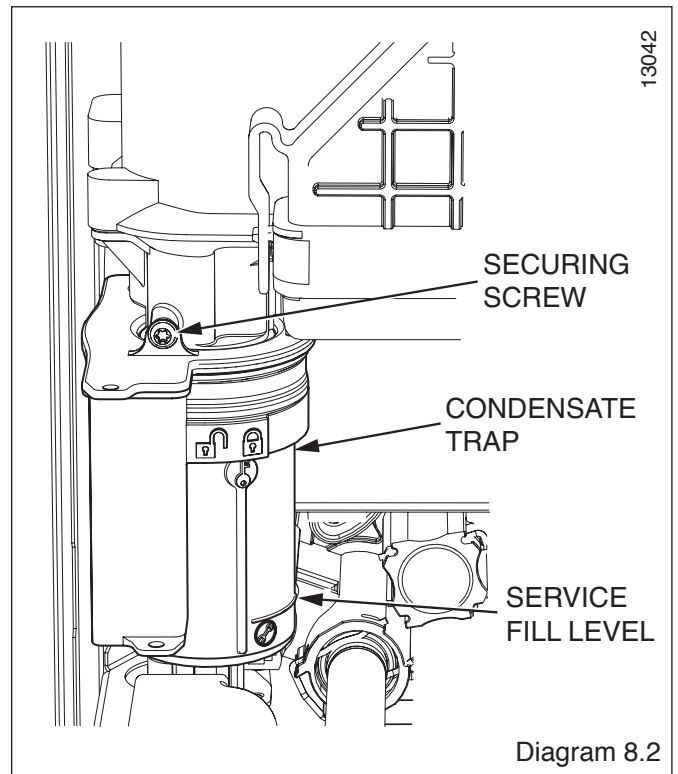
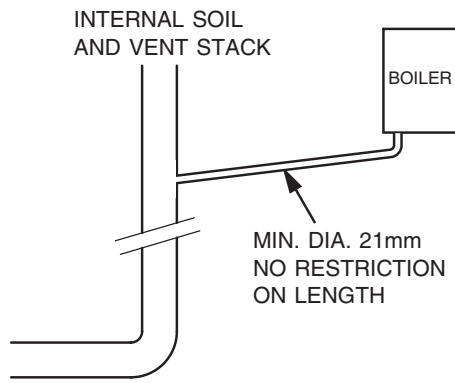

Diagram 8.2

8 Safety Discharge Valve & Condensate Connections

13000



Internal Soil and Vent Pipe

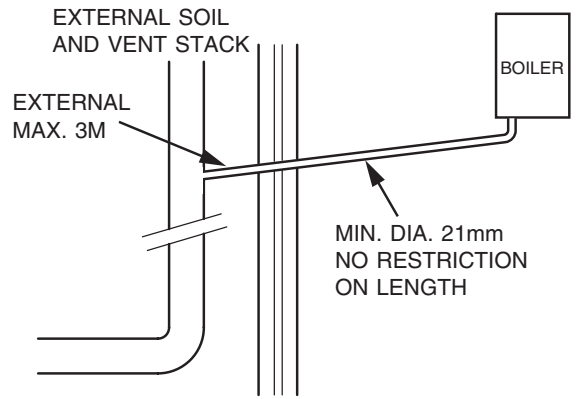

External Soil and Vent Pipe or Rainwater Pipe

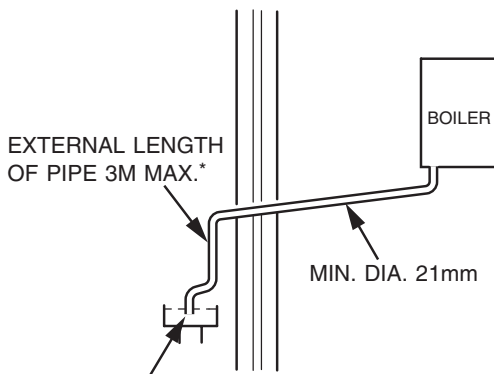

OPEN END OF PIPE DIRECT INTO GULLEY BELOW GROUND LEVEL BUT ABOVE WATER LEVEL

*NOTE: FOR EXTENDED PIPE RUNS 32mm DIA. PIPE SHOULD BE USED.

External Termination to a Gully or Hopper

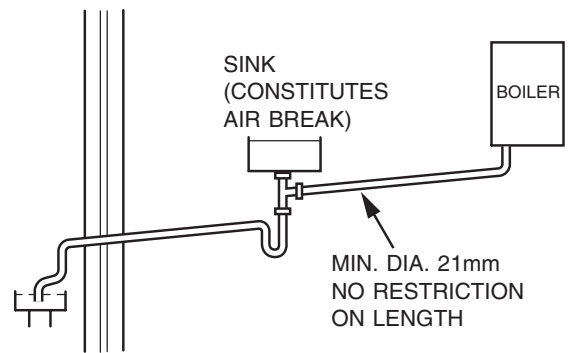

Internal Termination into Combined Sink Waste

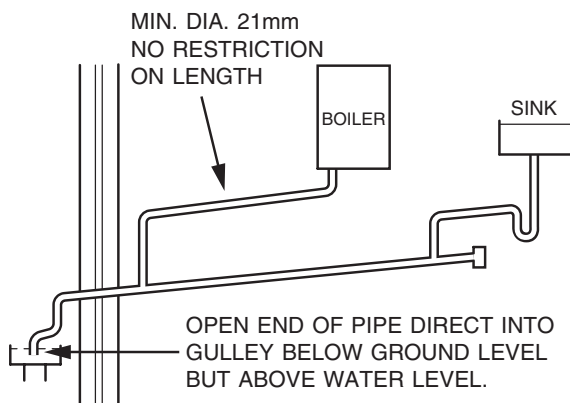

Internal Termination Downstream of Sink Waste

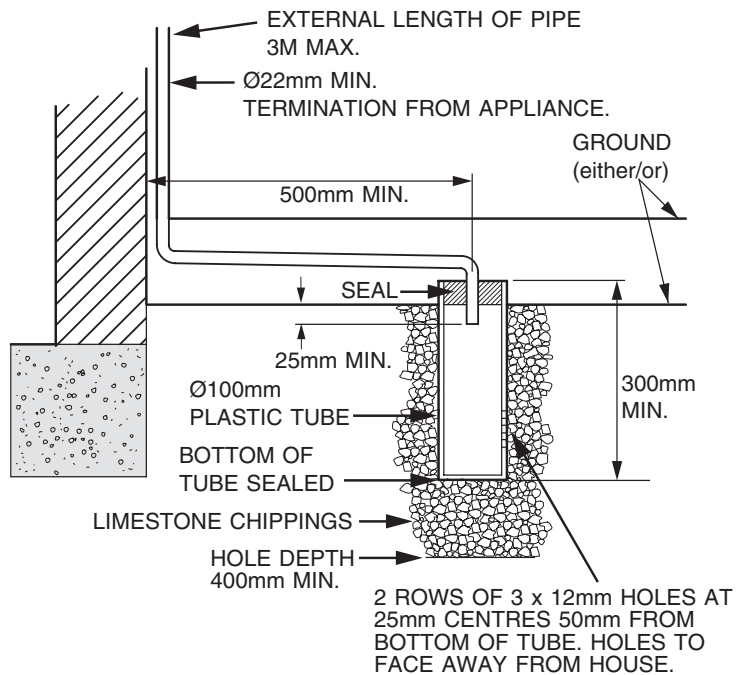

External Termination into Soakaway

NOTE: PIPEWORK SHOULD ALWAYS FALL AWAY FROM BOILER BY AT LEAST 2.5° 44mm FOR EVERY 1M.

Diagram 8.3

9 Flue Preparation and Installation

9.1 Top Horizontal Rear flue - Telescopic Part No. A2043600. Refer to diagram 9.1 for kit contents.

9.2 Flue Length

If a wall thickness of 232 min. to 437 max. is available the Top horizontal rear flue - telescopic can be used without extensions.

If the wall thickness is greater than 437 then using extensions a maximum horizontal flue length of 8 metres plus the Top horizontal rear flue - telescopic can be achieved. However, for every 90° or 45° elbows used the flue length MUST be reduced by 1 metre.

When extension pipes are used the flue system must be designed to have a continuous fall to the boiler of at least 44mm/metre (2.5°) to allow condensate to run back into the boiler and out via the drain.

9.3 Preparation

Remove the top flue outlet cover secured with four screws, see diagram 9.2.

Temporarily fit the flue elbow, measure the distance from the outside wall to flue elbow. If the measurement 'Y' exceeds 525mm, see diagram 9.3 then the appropriate length of extension pipe is required. If the dimension is less than 320mm DO NOT cut the flue, it can project beyond the outside wall face, see diagrams 9.4. If this is not desirable then a Top horizontal rear flue - standard MUST be used and cut to length.

9.4 Flue Fitting

Set the flue to the required length 'Y', ensure the air duct seams line up.

Remove the flue elbow.

Mark the securing hole position in the air duct. Drill a 3mm diameter hole at this position, take care not to pierce the inner flue duct. Secure with screw provided and tape the joint, see diagram 9.5.

Fit the sealing collar onto the locating ring on the flue terminal, see diagram 9.6.

Push the flue assembly into the wall, externally or internally, until the end of the assembly protrudes a short way from the inside face of the wall. This will enable the internal trim ring (if required) to be positioned and allow the flue assembly to be drawn back up to the flue elbow.

Secure the flue elbow in position on top of the boiler with four torque headed screws supplied.

Draw the flue assembly from wall and engage the flue duct into the elbow and butt fit between the air duct and flue elbow.

Ensure the correct alignment of the flue.

Fit the securing collar in position, mark through two of the pre drilled holes in the securing collar. Remove securing collar and drill two 3mm diameter holes one in the elbow and one in the air duct, take care not to pierce the inner flue duct. Fit the securing collar and secure with screws provided, see diagram 9.7.

Slide the internal trim ring back against the wall, securing in place with a small amount of sealant if required.

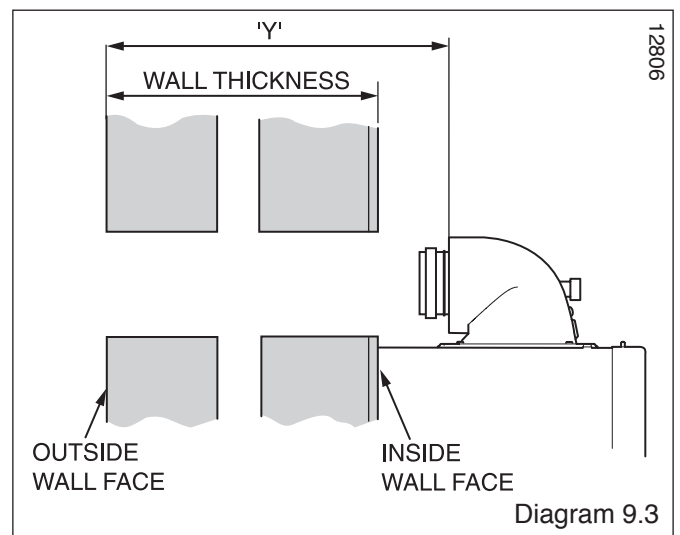
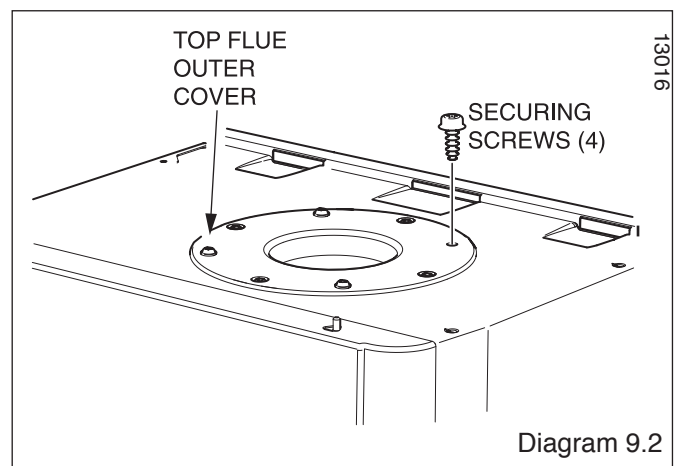
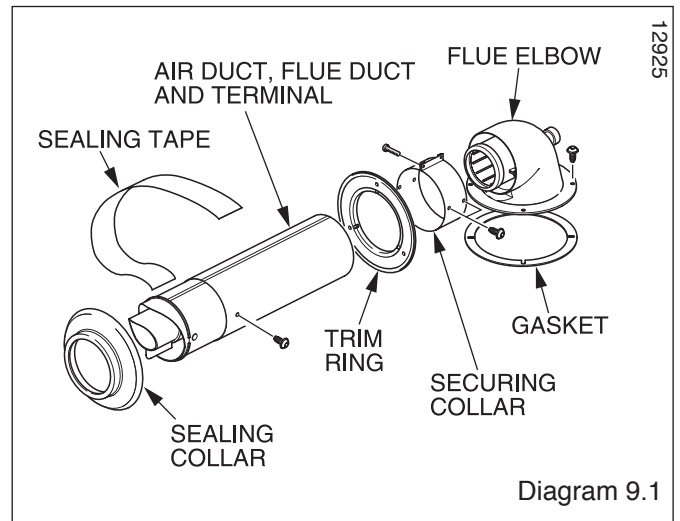

9 Flue Preparation and Installation

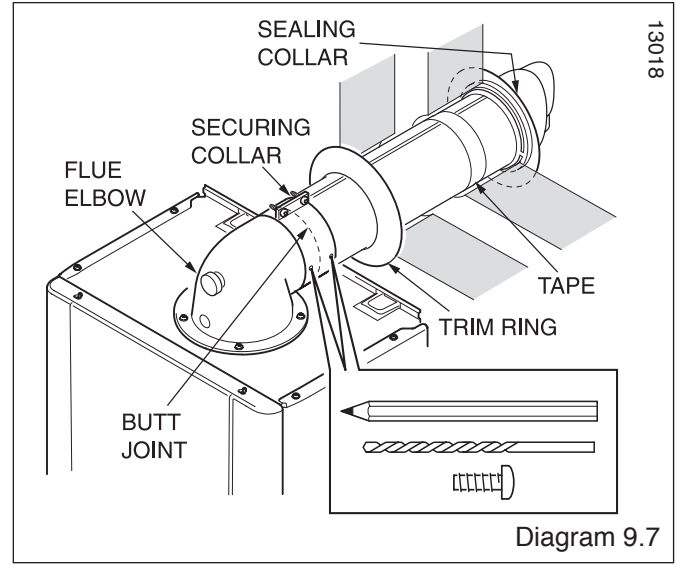
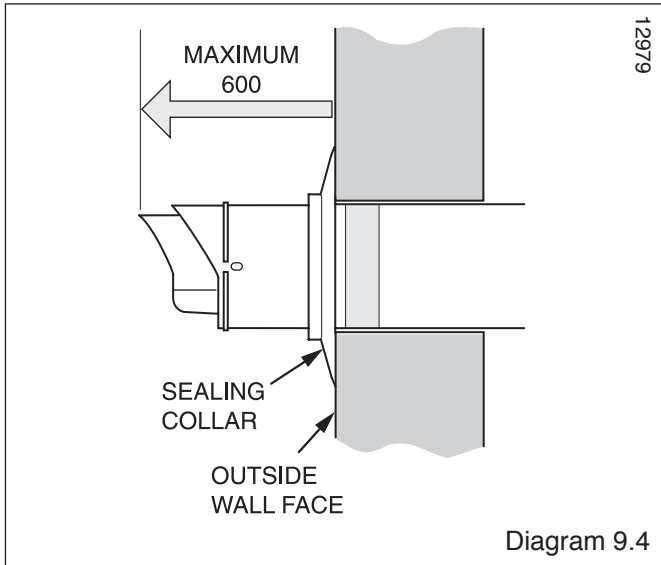

9.5 Top Horizontal Rear flue - Standard Part No. A2043400. Refer to diagram 9.8 for kit contents.

9.6 Flue Length

If a wall thickness of 75 min. to 507 max. is available the Top horizontal rear flue - standard can be used without extensions.

If the wall thickness is greater than 507 then using extensions a maximum horizontal flue length of 8 metres plus the Top horizontal rear flue - standard can be achieved. However, for every 90° or 45° elbows used the flue length MUST be reduced by 1 metre.

When extension pipes are used the flue system must be designed to have a continuous fall to the boiler of at least 44mm/metre (2.5°) to allow condensate to run back into the boiler and out via the drain.

Remove the top flue outlet cover secured with four screws, see diagram 9.2.

Temporarily fit the flue elbow, measure the distance from the outside wall to flue elbow. If the measurement 'Y' exceeds 652mm, then the appropriate length of extension pipe is required. The minimum dimension is 187 to suit a 75 min. wall thickness, see diagram 9.3.

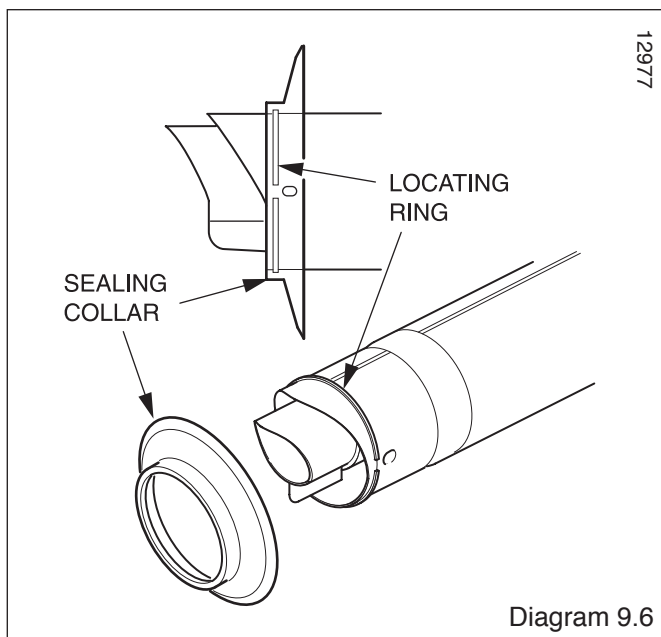
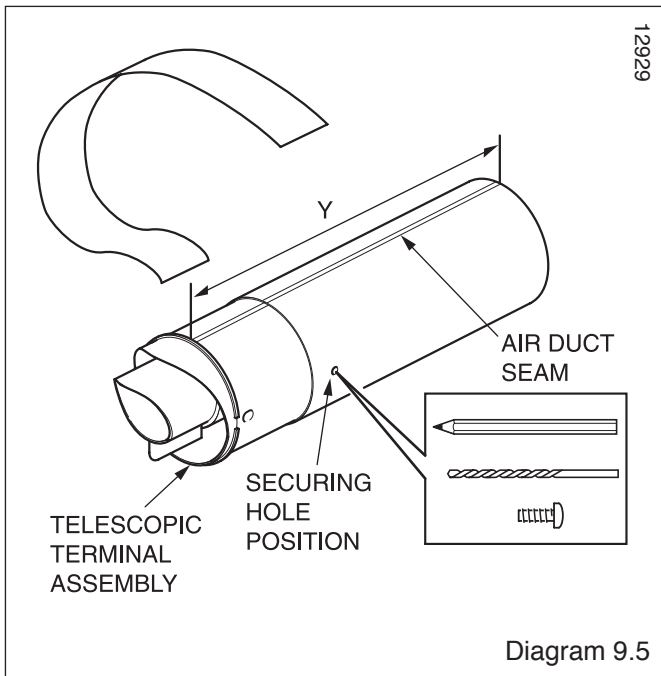

9.7 Flue Fitting

Remove the flue elbow.

Separate the flue duct from the terminal by twisting to release the terminal catch, then pull out of the retaining seal, refer to diagram 9.9.

The flue duct cutting length (L + 11mm.) is shown in diagram 9.9.

The air duct should be cut at the opposite end to the terminal

The plastic flue duct MUST be cut at the opposite end to the terminal catch.

The plastic flue duct extensions MUST be cut at the opposite end to the seal.

9 Flue Preparation and Installation

The cut ducts must be de-burred and all filings and debris removed.

Insert the flue duct into the air duct terminal assembly, remembering to engage the catch within the terminal.

NOTE: If you require to lubricate the seals to ease installation, please do not use a mineral oil based grease, we would recommend the use of water.

Fit the sealing collar onto the locating ring on the flue terminal, see diagram 9.6.

Push the flue assembly into the wall, externally or internally, initially until the end of the assembly protrudes a short way from the inside face of the wall. This will enable the internal trim ring (if required) to be positioned and allow the flue assembly to be drawn back into the flue elbow.

Secure the flue elbow in position on top of the boiler with four torque headed screws supplied.

Draw the flue assembly from wall and engage the flue duct into the elbow and butt fit between the air duct and flue elbow.

Ensuring the correct alignment of the terminal.

Fit the securing collar into position, mark through two of the pre drilled holes in the securing collar. Remove securing collar and drill two 3mm diameter holes one in the elbow and one in the air duct, take care not to pierce the inner flue duct. Fit the securing collar and secure with screws provided, see diagram 9.10.

Slide the internal trim ring back against the wall, securing in place with a small amount of sealant if required.

NOTE: If the air and flue ducts have been correctly cut to the instructions given, the sealing collar should fit flush with the outside wall, check this.

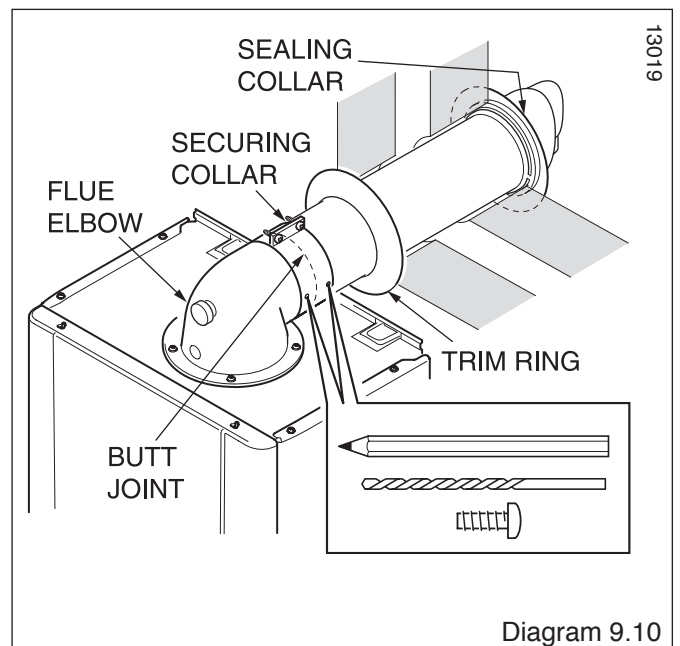
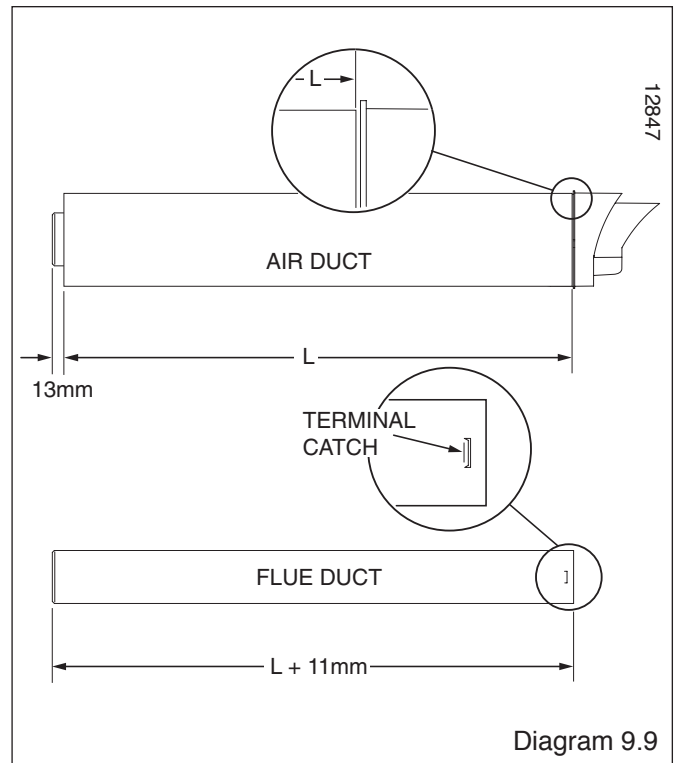
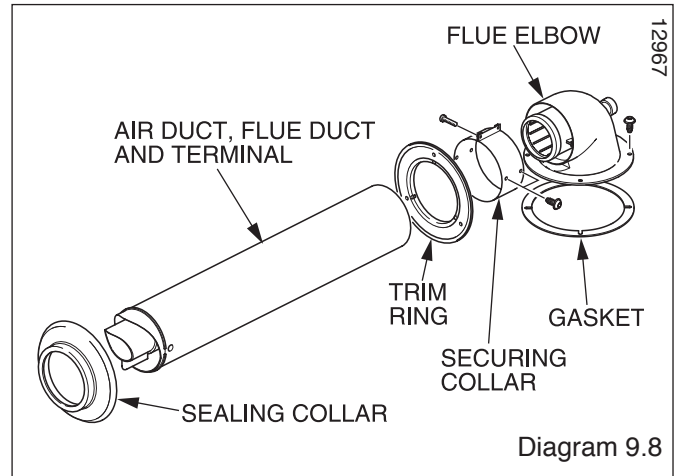

9 Flue Preparation and Installation

9.8 Top Horizontal Side flue - Telescopic Part No. A2043600. Refer to diagram 9.1 for kit contents.

9.9 Flue Length

The maximum permissible horizontal flue length is 8 metres plus the Top horizontal side flue - telescopic. This can be achieved by the use of the 44mm/metre (2.5°), however, for every 90° or 45° elbows used the flue length MUST be reduced by 1 metre.

When extension pipes are used the flue system must be designed to have a continuous fall to the boiler of at least 44mm/metre (2.5°) to allow condensate to run back into the boiler and out via the drain.

9.10 Preparation

Remove the top flue outlet cover secured with four screws, see diagram 9.2.

Temporarily fit the flue elbow, measure the distance from the outside wall to flue elbow. If the measurement 'Y' exceeds 525mm, see diagram 9.11 then the appropriate length of extension pipe is required. If the dimension is less than 320mm DO NOT cut the flue, it can project beyond the outside wall face, see diagrams 9.4. If this is not desirable then a Top horizontal side flue - standard MUST be used and cut to length.

9.11 Flue Fitting

Set the flue to the required length 'Y', ensure the air duct seams line up.

Remove the flue elbow.

Mark the securing hole position in the air duct. Drill a 3mm diameter hole at this position, take care not to pierce the inner flue duct. Secure with screw provided and tape the joint, see diagram 9.5.

Fit the sealing collar onto the locating ring on the flue terminal, see diagram 9.6.

Push the flue assembly into the wall, externally or internally, until the end of the assembly protrudes a short way from the inside face of the wall. This will enable the internal trim ring (if required) to be positioned and allow the flue assembly to be drawn back up to the flue elbow.

Secure the flue elbow in position on top of the boiler with four torque headed screws supplied.

Draw the flue assembly from wall and engage the flue duct into the elbow and butt fit between the air duct and flue elbow.

Ensure the correct alignment of the flue.

Fit the securing collar in position, mark through two of the pre drilled holes in the securing collar. Remove securing collar and drill two 3mm diameter holes one in the elbow and one in the air duct, take care not to pierce the inner flue duct. Fit the securing collar and secure with screws provided, see diagram 9.12.

Slide the internal trim ring back against the wall, securing in place with a small amount of sealant if required.

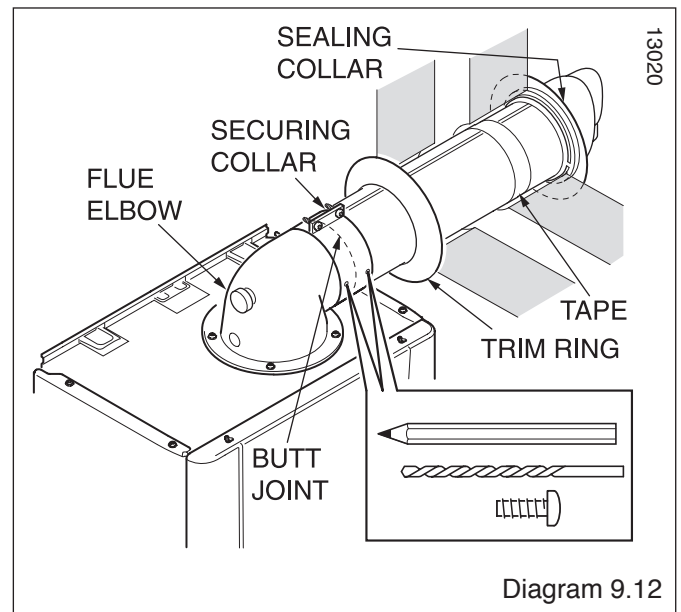
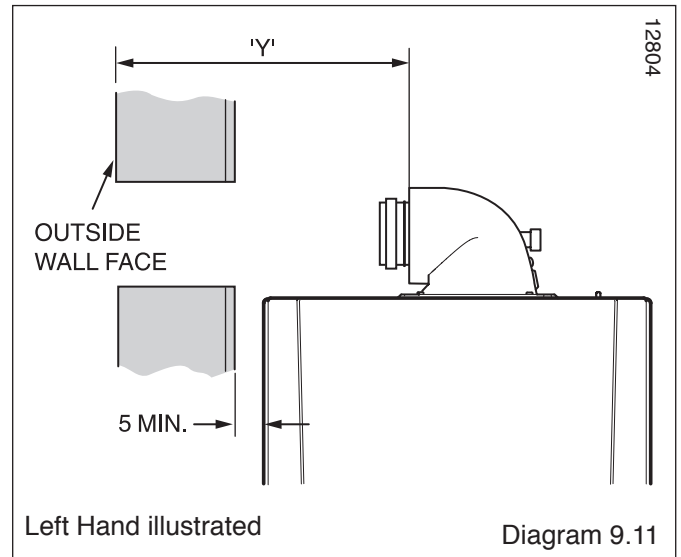

9 Flue Preparation and Installation

9.12 Top Horizontal Side flue - Standard Part No. A2043400. Refer to diagram 9.8 for kit contents.

9.13 Flue Length

Remove the top flue outlet cover secured with four screws, see diagram 9.2.

Temporarily fit the flue elbow, measure the distance from the outside wall to flue elbow. If the measurement 'Y' exceeds 652mm, then the appropriate length of extension pipe is required. The minimum dimension for LH is 270 and RH 242 to suit a minimum wall thickness of 75mm, see diagram 9.11.

9.14 Flue Fitting

Remove the flue elbow.

Separate the flue duct from the terminal by twisting to release the terminal catch, then pull out of the retaining seal, refer to diagram 9.9.

The flue duct cutting length ($L + 11\text{mm.}$) is shown in diagram 9.9.

The air duct should be cut at the opposite end to the terminal

The plastic flue duct **MUST** be cut at the opposite end to the terminal catch.

The plastic flue duct extensions **MUST** be cut at the opposite end to seal.

The cut ducts must be de-burred and all filings and debris removed.

Insert the flue duct into the air duct terminal assembly, remembering to engage the catch within the terminal.

NOTE: If you require to lubricate the seals to ease installation, please do not use a mineral oil based grease, we would recommend the use of water.

Fit the sealing collar behind the locating lugs on the flue terminal, see diagram 9.6.

Push the flue assembly into the wall, externally or internally, initially until the end of the assembly protrudes a short way from the inside face of the wall. This will enable the internal trim ring (if required) to be positioned and allow the flue assembly to be drawn back into the flue elbow.

Secure the flue elbow in position on top of the boiler with four torque headed screws supplied.

Draw the flue assembly from wall and engage the flue duct into the elbow and butt fit between the air duct and flue elbow.

Ensuring the correct alignment of the terminal.

Fit the securing collar into position, mark through two of the pre drilled holes in the securing collar. Remove securing collar and drill two 3mm diameter holes one in the elbow and one in the air duct, take care not to pierce the inner flue duct. Fit the securing collar and secure with screws provided, see diagram 9.13.

Slide the internal trim ring back against the wall, securing in place with a small amount of sealant if required.

NOTE: If the air and flue ducts have been correctly cut to the instructions the sealing collar should fit flush with the outside wall, check this.

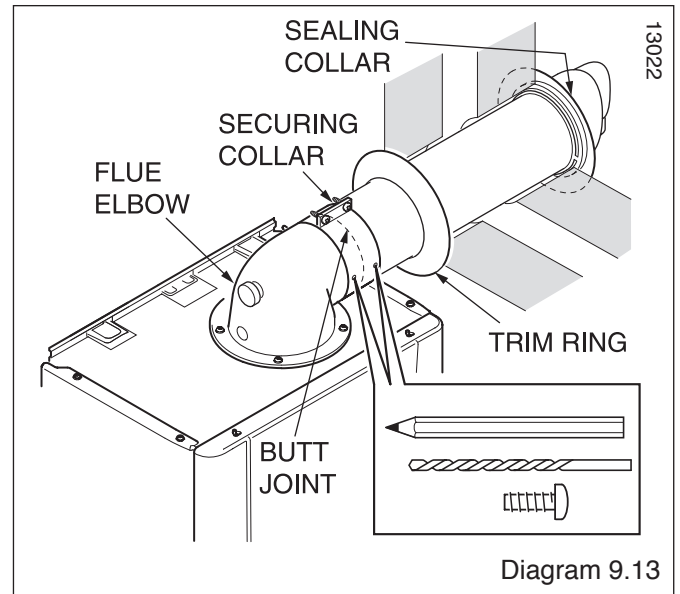

9 Flue Preparation and Installation

9.15 Rear flue - Telescopic Part No. A2043500. Refer to diagram 9.14 for kit contents.

9.16 Flue Length

Measure the distance from the outside wall to the inside wall face. This measurement must not exceed 512mm. if the dimension is less than 291mm DO NOT cut the flue, it can project to its maximum.

9.17 Flue Fitting

Set the flue to the required length 'Y' plus 24mm MIN to 28mm MAX, see diagram 9.16, ensure the air duct seams line up. Mark the securing hole position in the air duct. Drill a 3mm diameter hole at this position, take care not to pierce the inner flue duct. Secure with screw provided and tape the joint, see diagrams 9.14 and 9.15.

Fit the sealing collar onto the locating ring on the flue terminal, see diagram 9.6.

Push the telescopic terminal assembly into the wall, externally or internally, initially.

Draw the telescopic flue through the wall and engage the telescopic terminal assembly into the clamping band grips. The telescopic terminal assembly must be pulled forward of the clamping band grips by the dimension shown in diagram 9.16 to ensure a good seal when the boiler is located onto the fixing plate.

Ensuring the correct alignment of the terminal.

Secure the telescopic terminal assembly using the clamping band supplied. The position of the clamping band securing screw is important, refer to label and wall template.

IMPORTANT: CHECK THE CLAMPING BAND IS SUFFICIENTLY TIGHTENED TO AVOID ANY MOVEMENT OF THE FLUE WHEN FITTING THE BOILER.

Remove the rear flue outlet cover secured with four screws.

Fix the boiler to the wall, refer to Section 6 Boiler Fixing.

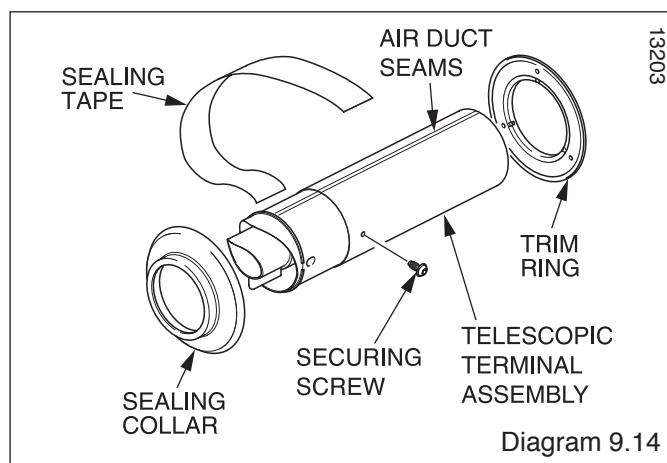
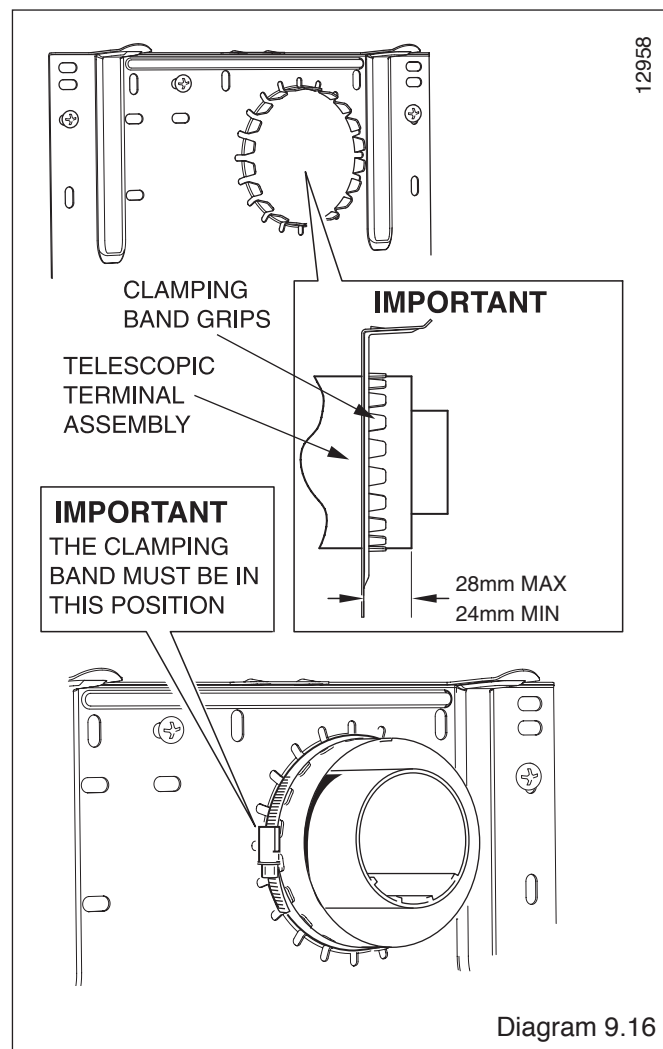
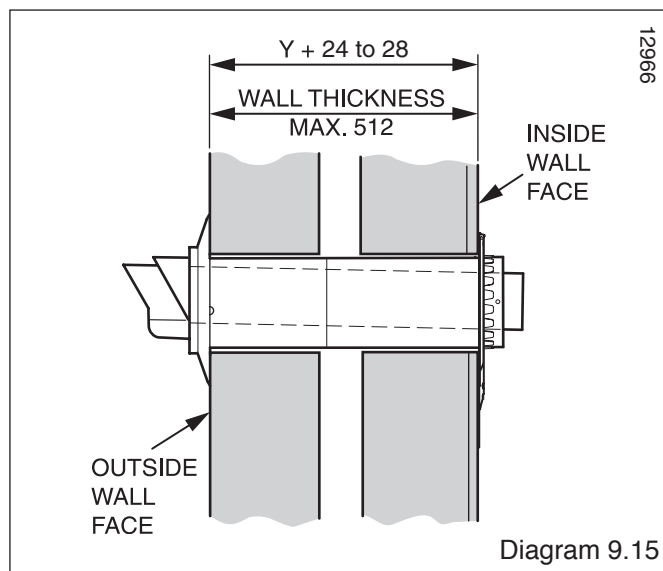

9 Flue Preparation and Installation

9.18 Vertical flue

The vertical flue system is available as an option where the boiler position does not permit the use of the top horizontal or rear flue system.

The system is made up of accessories. The accessories include terminal assembly, bends 45° and 90°, flue extensions, fixing bracket and appropriate weather collar, see diagram 9.17.

The maximum permitted straight flue length is 8 metres plus the terminal. for each 90° or 2x45° bends fitted, the maximum length must be reduced by 1 metre, see diagram 9.22.

NOTE: 2x45° bends can replace 1x90° bend if necessary. When using 90° bends any horizontal extension pipe should be inclined by a minimum of 44mm/metre (2.5°) towards the boiler to facilitate condense removal, see (a) in diagram 9.22.

Alternatively use 45° bends to avoid horizontal runs, see (b) in diagram 9.22.

The terminal should be positioned at least 600mm from any opening into the building, refer to diagram 3.2.

Measure the distance of flue length required for the installation.

The flue must be designed with a continuous fall towards the boiler.

Remove the top flue outlet cover secured with four screws, see diagram 9.2.

Refer to diagram 9.18. Secure the flue adapter in position on top of the boiler with four torx headed screws supplied, making sure the nib fits into the locating slot in the boiler casing to ensure correct orientation.

The rubber 'O' rings of each section should be lubricated prior to assembly.

NOTE: Do not use mineral oils or grease, silicon grease or water is recommended.

Secure the first extension pipe to the flue adapter with the securing collar supplied by positioning the collar centrally over the joint, then tighten the two screws on the securing collar, see diagram 9.19.

Fit more extension pipes as required using the collar and screws supplied with each extension pipe. To fit position the collar centrally over the joint, tighten the two screws on the securing collar. Using the holes provided in the securing collar drill and insert the two self tapping screws supplied, see diagram 9.20.

The rubber 'O' rings of each section should be lubricated prior to assembly.

NOTE: Do not use mineral oils or grease, silicon grease or water is recommended.

When building the flue up it is recommended that it is supported every 2 metres and at every bend by a fixing bracket.

Project the rise of the flue pipe to roof level and cut a 150mm hole in the roof.

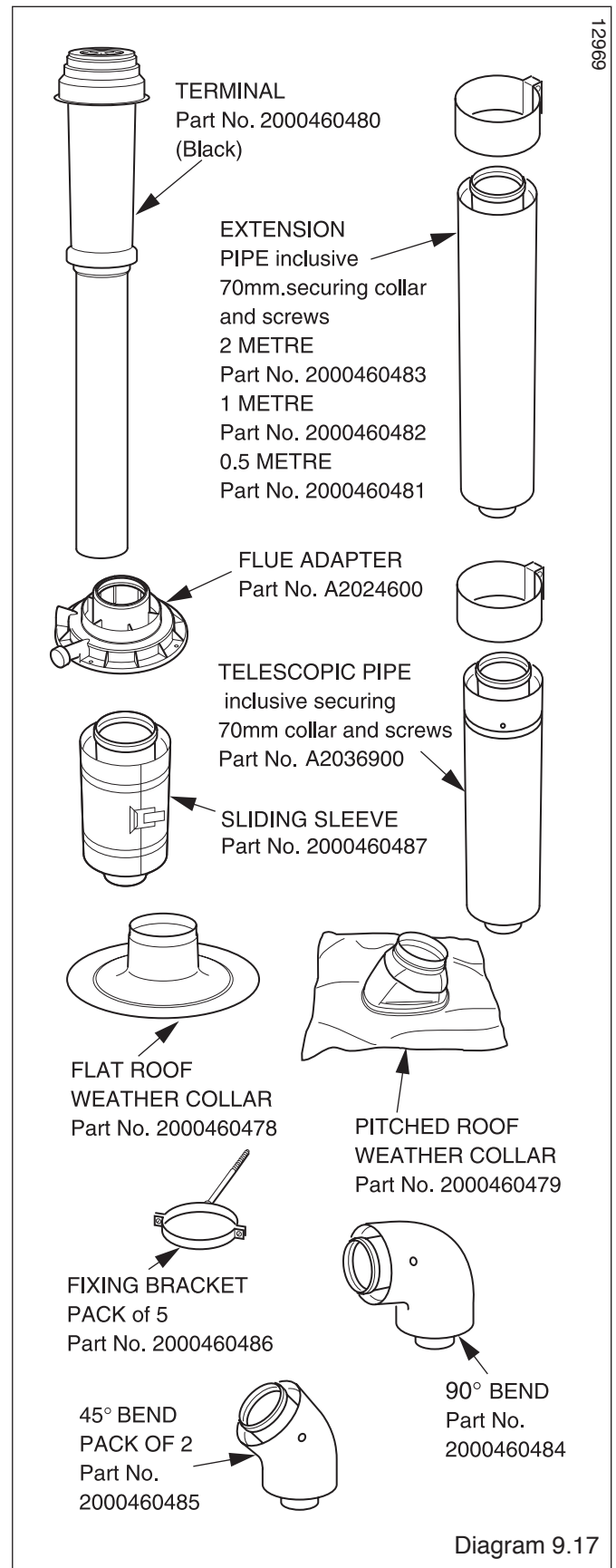

9 Flue Preparation and Installation

Flue Terminal Installation

(a) Pitched Roof

Fit the required pitched roof weather collar over the 150mm hole in the roof. Make good the tiling or slating around the collar incorporating the flashing of the weather collar. Position the angle cap over the weather collar in the correct orientation to attain the correct angle for your roof.

(b) Flat Roof

Fit the aluminium weather collar over the 150mm hole in the roof ensuring a weather tight seal.

From above carefully place the flue terminal through the weather collar.

Completion of Installation

With the flue terminal positioned in the roof the length of the final pipe can be determined. If a telescopic length cannot be used, then a standard flue length can be cut to make the correct length. Cut the flue to the desired length measuring from the 'O' ring end and discard the plain end of the tube. The cuts must be square and made free of burrs to allow correct assembly. (**NOTE:** The flue pipe is 10mm longer than the air pipe), see diagram 9.21. Carefully push the terminal assembly upwards to allow room for fitting the final flue piece. Fit a fixing bracket to the terminal assembly. Pull the terminal assembly down and join to the flue system. Ensure that the terminal is making a weather tight seal on the weather collar. Secure the fixing bracket fitted to the terminal to the roofing struts or a purpose made baton.

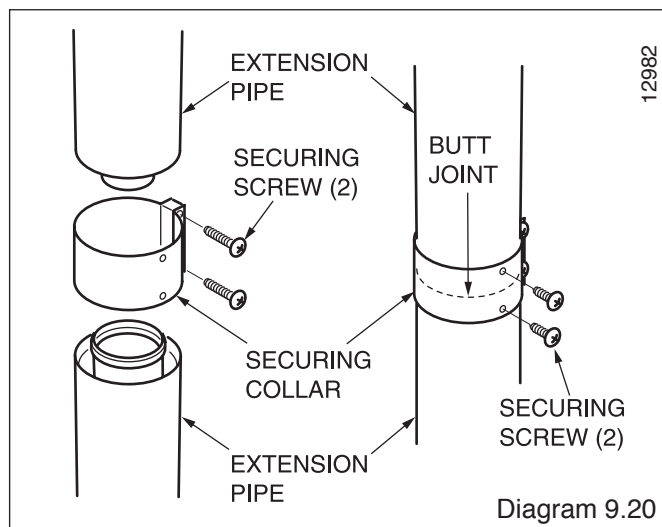
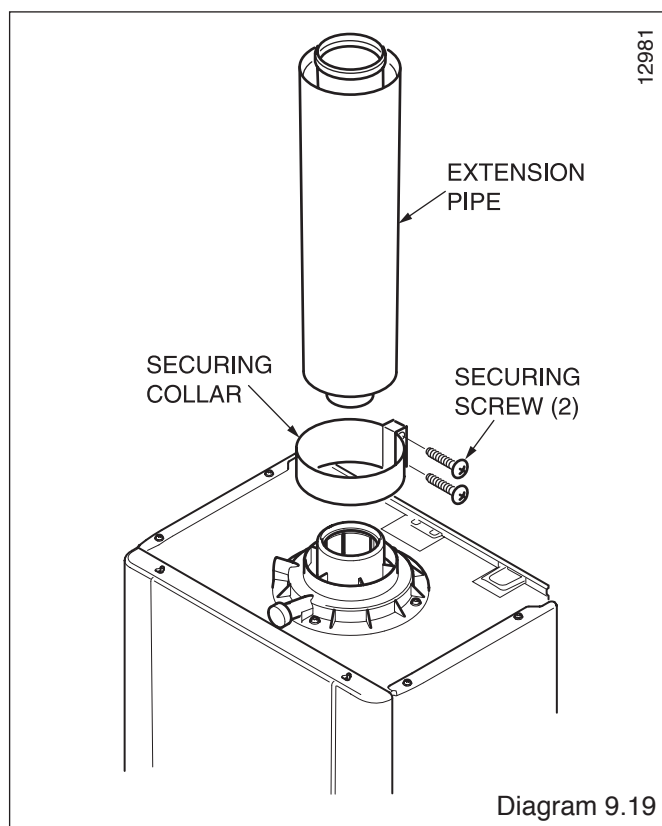
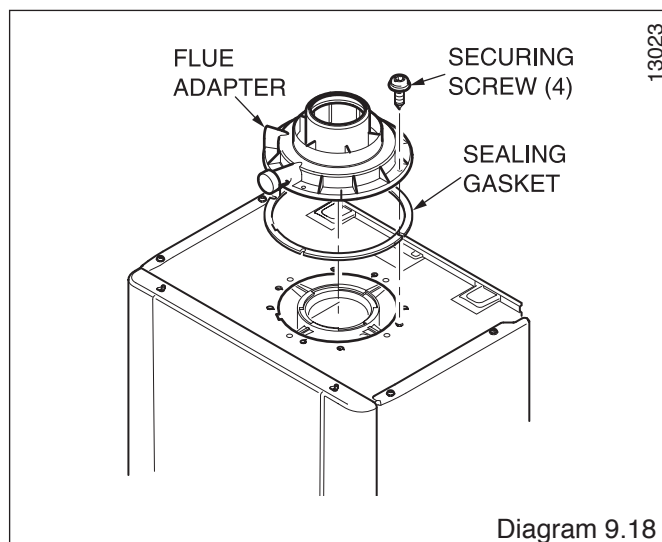

9 Flue Preparation and Installation

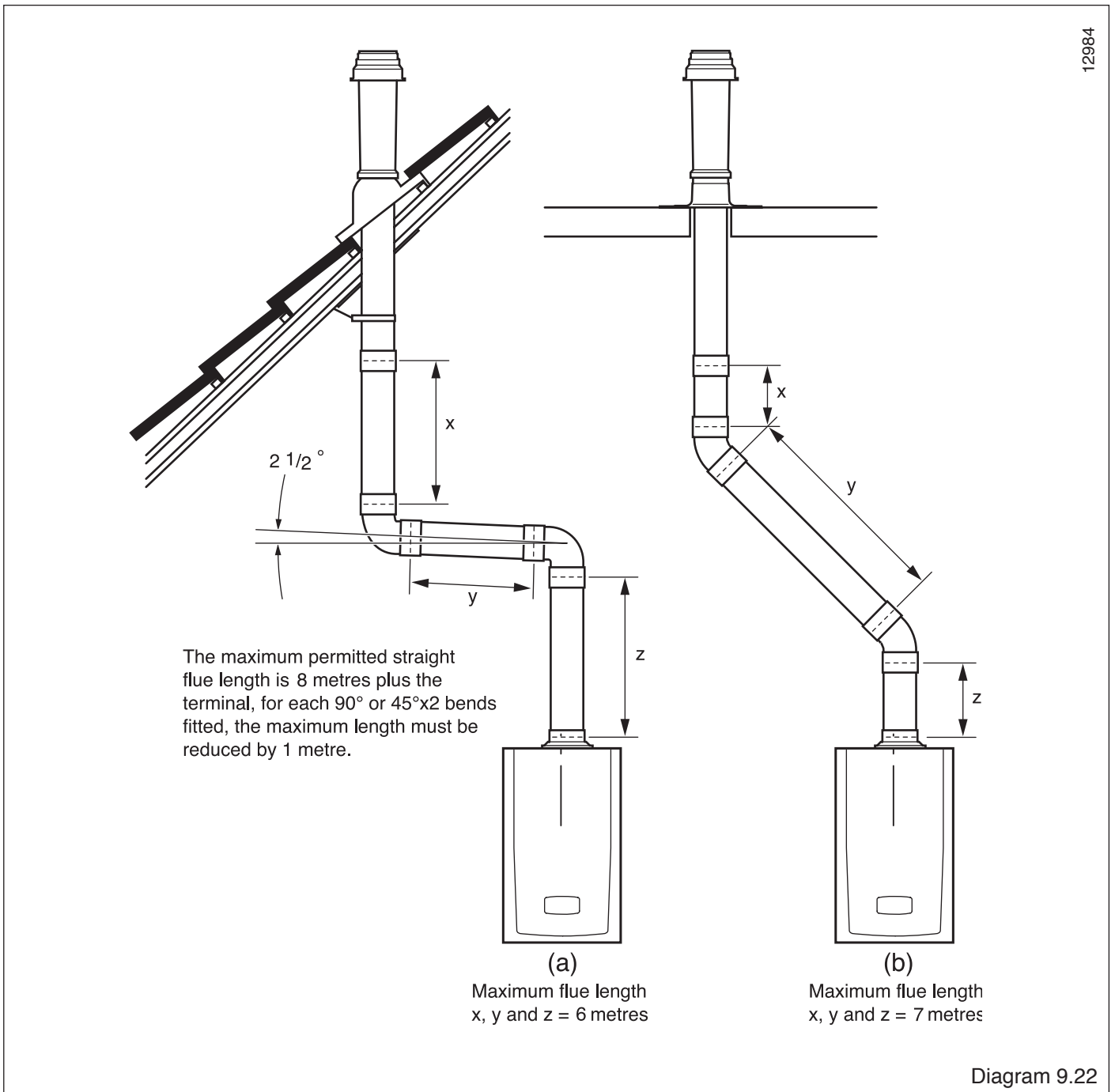
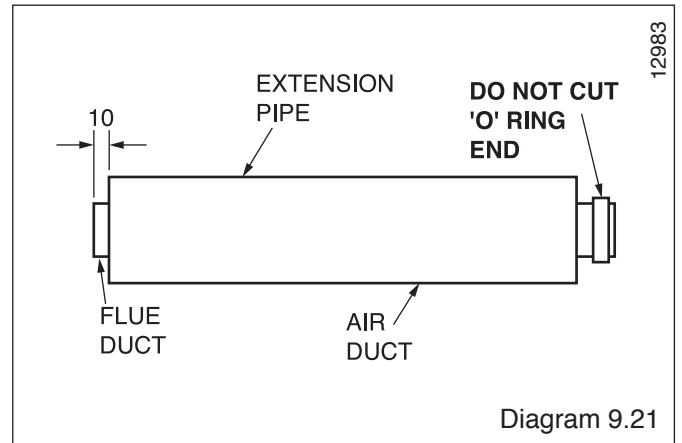

9 Flue Preparation and Installation

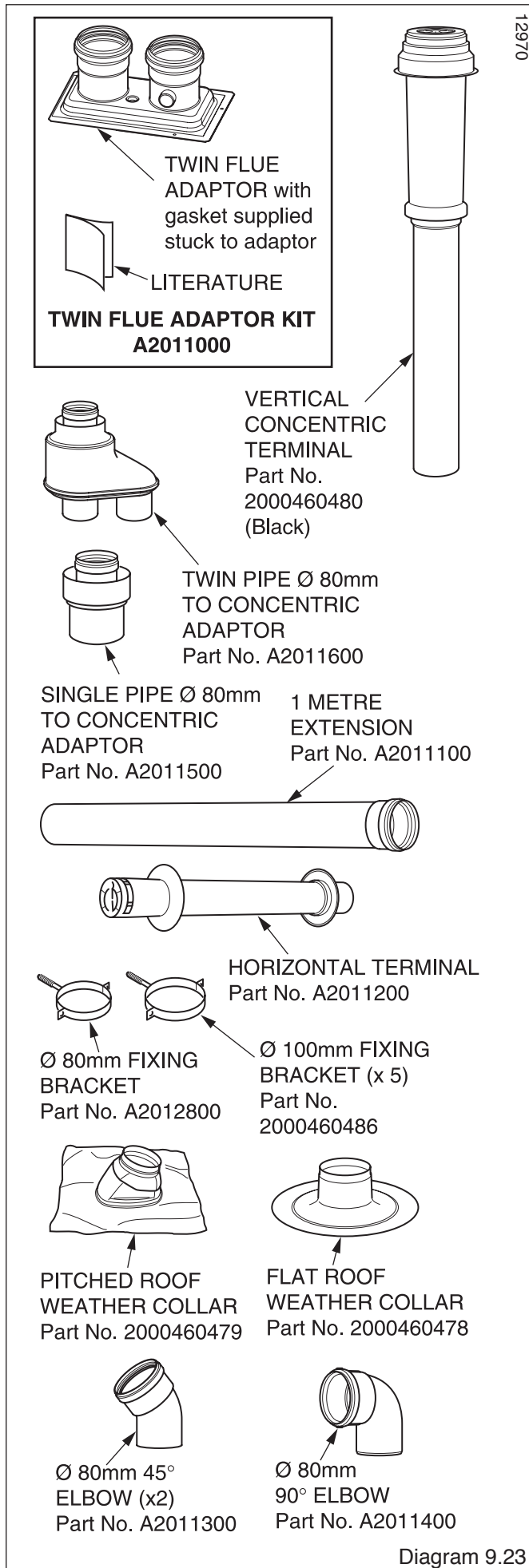

Diagram 9.23

9.19 Twin flue

The twin flue system is available as an option when the top horizontal, rear or vertical flue system is not appropriate.

The system can provide an independent horizontal air inlet and flue outlet, horizontal air inlet and vertical flue outlet or vertical air inlet and flue outlet via a concentric terminal.

NOTE: The air and flue outlets do not have to be equal lengths. 2x45° bends can replace 1x90° bend if necessary.

The maximum permitted straight pipe length is 40 metres plus terminal assemblies, for each 90° or 45° x 2 bends fitted, the maximum length must be reduced by 1 metre.

NOTE: When using 90° bends any horizontal run should be inclined by a minimum of 44mm/metre (2.5°) towards the boiler to facilitate condensate removal.

Alternatively use 45° bends to avoid horizontal runs in the flue pipe.

Terminal Position

The clearances for a flue outlet are given in the "Flue Location and Ventilation" section.

In addition the horizontal air inlet must not be closer than 300 mm from a flue outlet on the same wall or 1200mm from an opposing flue outlet.

Installation Details

The parts available for a twin flue system installation are shown in diagram 9.23.

Boiler Connection

Remove the top flue outlet cover secured with four screws, see diagram 9.2.

Push the twin flue adaptor onto the outlet of the boiler with the air inlet to the left hand side. Secure the adaptor to the top panel with the screws provided. Care should be taken when inserting the screw through the hole in adaptor top.

To facilitate engagement, it is recommended that the rubber 'O' rings are lubricated with silicone grease or water prior to assembly.

See diagram 9.24.

Air and Flue Pipe Installation

The air and flue pipes can now be built up from the boiler.

The flue must be designed with a continuous fall towards the boiler. If using the horizontal flue pipe or 90° bends the pipe must be inclined at 44mm/metre (2.5°) minimum, see diagram 9.25.

Alternatively if space allows, use 45° bends in place of 90° bends.

The rubber 'O' rings of each section should be lubricated prior to assembly with silicone grease.

When building the flue up it is recommended that it is supported every 2 metres and at every bend by a fixing bracket.

9 Flue Preparation and Installation

Horizontal Terminal Installation

With due consideration to terminal clearances mentioned in Section 3.2 drill the one or two holes as required with a 90mm core drill.

Push the horizontal terminal through the wall allowing approx. 100mm to protrude outside.

Push a grey rubber wall seal onto either side of the wall ensuring that both wall seals are pushed up to the wall surface, see examples (b) and (c) diagram 9.25.

Vertical Terminal Installation

With due consideration to terminal clearances mentioned in Section 3.2, project the rise of the flue pipe to roof level and cut 150mm hole in the roof.

(a) Pitched Roof

Fit the required pitched roof weather collar over the 150mm hole in the roof. Make good the tiling or slating around the collar incorporating the flashing of the weather collar. Position the angle cap over the weather collar in the correct orientation to attain the correct angle for your roof. One way round gives a pitch of 25°-38° and the other gives 37°- 50°.

(b) Flat Roof

Fit the aluminium weather collar over the 150mm hole in the roof ensuring a weather tight seal.

Horizontal Pipes-Completion of Installation

Having built the pipe(s) from the boiler to the terminal(s), the length of the final pipe piece can be determined. Cut pipes at the opposite end to the 'O' ring seal making square and free from burrs. Push the horizontal terminal through the wall to engage the final pipe piece and pull back ensuring the grey wall seals are fully pulled up to the outside and inside wall faces.

Vertical Pipes-Completion of Installation

Refer to diagram 9.25.

For installation of (a), attach the twin pipe to concentric flue adaptor, part number A2011600, to the base of vertical terminal assembly. For installation of (b), attach the single pipe to concentric adaptor, part number A2011500, to the base of vertical terminal assembly.

With the vertical terminal assembly positioned in the roof, the length of the final pipe can be determined. Cut the flue to the desired length measuring from the 'O' ring seal end and discard the plain end of the tube. The cut end should be square and free from burrs. Carefully push the terminal assembly upwards to allow room for fitting the final flue piece(s). Fit a 100mm fixing bracket to the terminal assembly Part No2000460486. Pull the terminal assembly down and join to the flue system. Ensure that the terminal is making a weather tight seal on the weather collar. Secure the fixing bracket fitted to the terminal to the roofing struts or a purpose made batton.

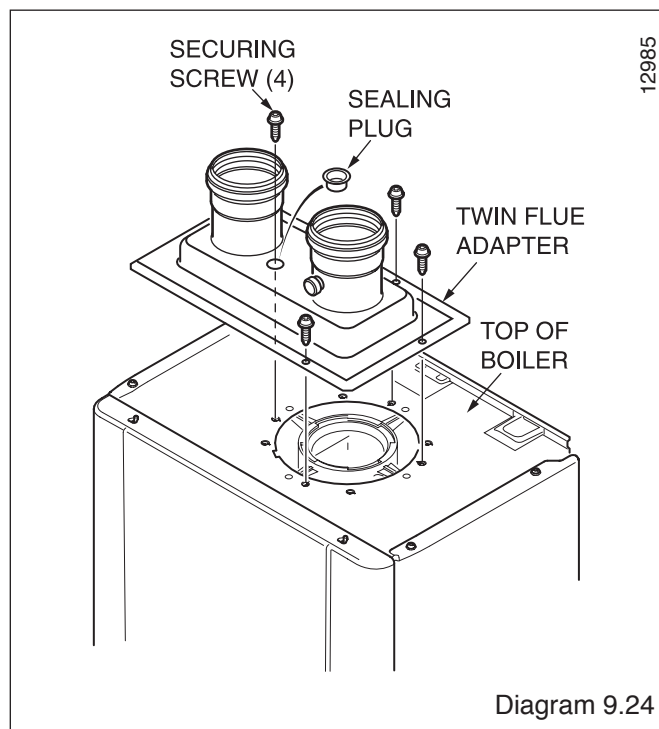

9 Flue Preparation and Installation

12987

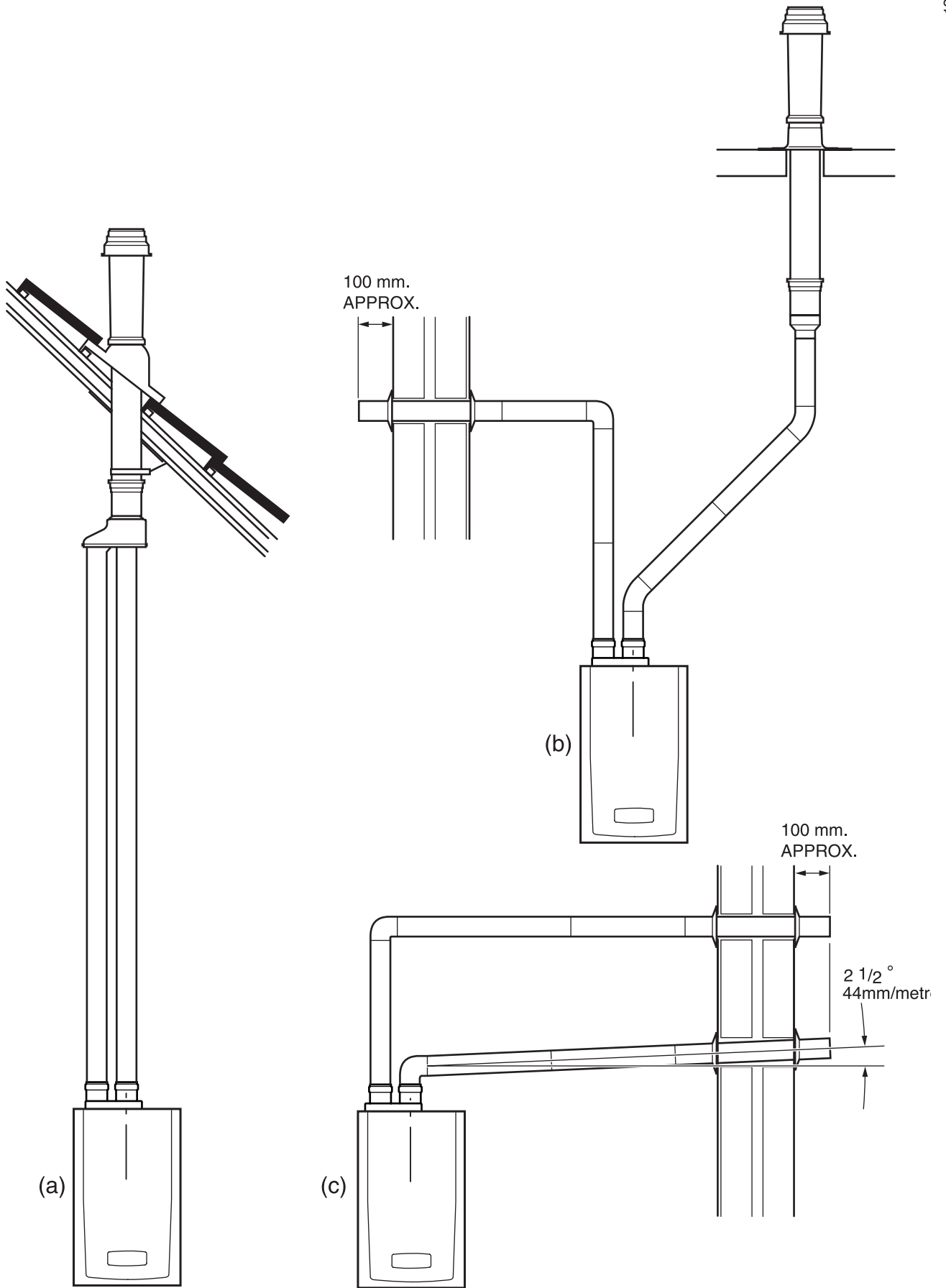

Diagram 9.25

9 Flue Preparation and Installation

12997

IMPORTANT: The flue outlet must not be positioned within 300mm from an opening, air brick or opening windows.

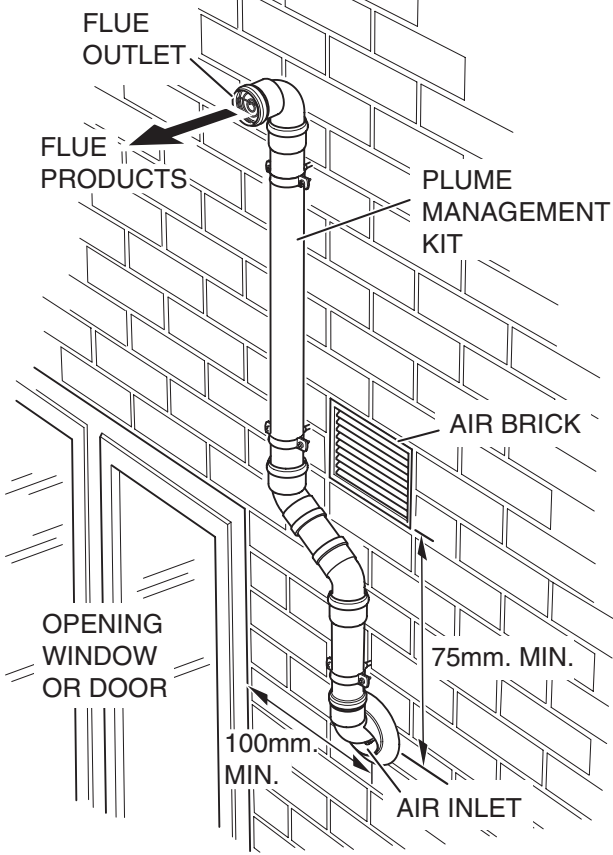

Diagram 9.26

9.20 Plume Management Kit

The Plume Management Kit: Part No. A2044100 (white) or A2044000 (black) can be used to overcome many site issues.

The Plume Management Kit will fit to the Top Horizontal Telescopic, Rear Horizontal Telescopic and Standard Horizontal Flue. This enables the flue products to exhaust further away from the boiler, thereby reducing the impact of pluming 6M. The flue air inlet can be sited closer to doors, opening windows and air bricks, see diagram 9.26.

The maximum length of the Plume Management Kit must NOT exceed 6m with a horizontal concentric flue length of 2m max.

For each 90° bend or 2 x 45° bends the maximum length of the Plume Management Kit must be reduced by 1m.

For more information contact Glow-worm, refer to page 2.

The Plume Management Kit is supplied with installation instructions.

10 Electrical Connection

WARNING: This appliance must be earthed.

This appliance must be wired in accordance with these instructions. Any fault arising from incorrect wiring cannot be put right under the terms of the Glow-worm guarantee.

All system components must be of an approved type.

Electrical components have been tested to meet the equivalent requirements of the BEAB.

Do not interrupt the mains supply with a time switch or programmer.

Connection of the whole electrical system and any heating system controls to the electrical supply must be through a common isolator.

Isolation should preferably be by a double pole switched fused spur box having a minimum contact separation of 3mm on each pole. The fused spur box should be readily accessible and preferably adjacent to the boiler. It should be identified as to its use.

10.1 Installer Interface

Gain access to the Installer Interface by removing the securing screw, see diagram 10.1.

Remove the cable securing clip which will release the Installer Interface cap, see diagram 10.1.

Release the cable gland, route the mains and system cables through the strain relief and connect to the relevant plug dependant upon your choice of system controls, see diagram 10.2.

10.2 Electrical Connections - Testing

Carry out preliminary electrical system checks as below:

1. Test insulation resistance to earth of mains cables.
2. Test the earth continuity and short circuit of cables.
3. Test the polarity of the mains.

IMPORTANT NOTE

ALL electrical connections to the boiler must be permanently fixed to a wall or a sturdy support feature in a tidy manner.

10 Electrical Connection

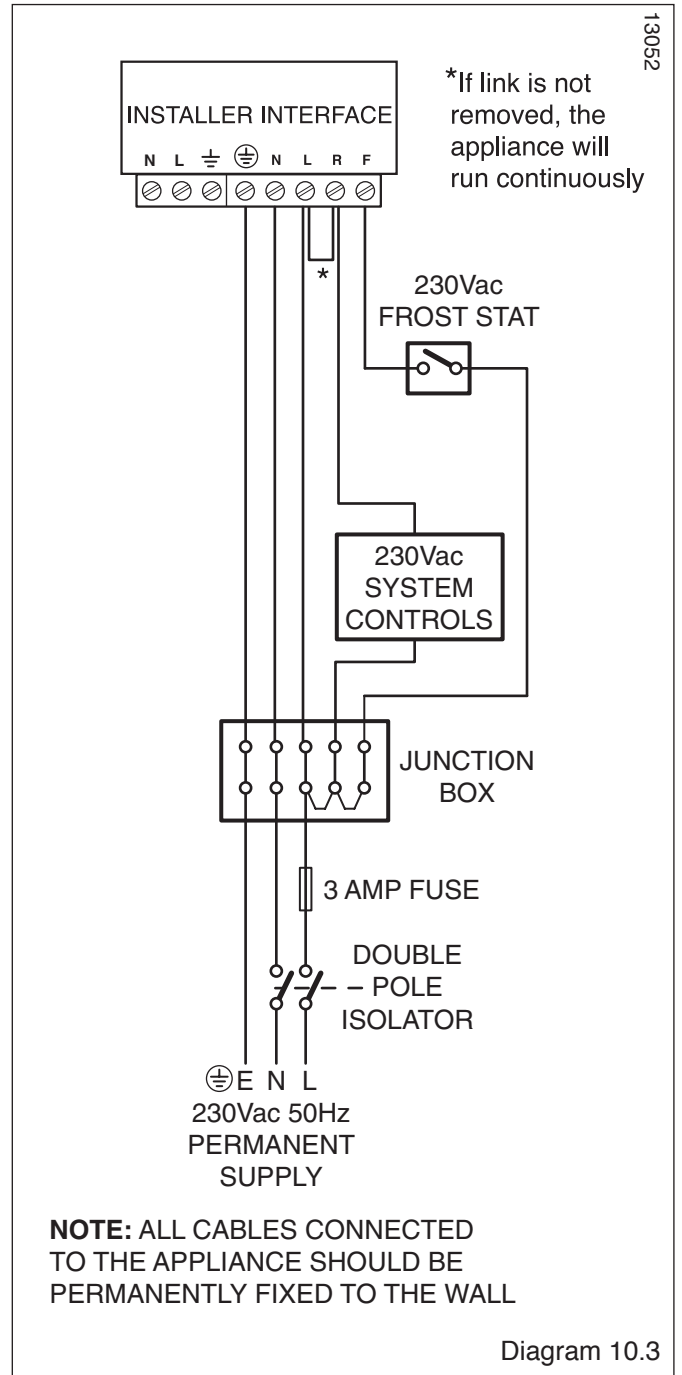
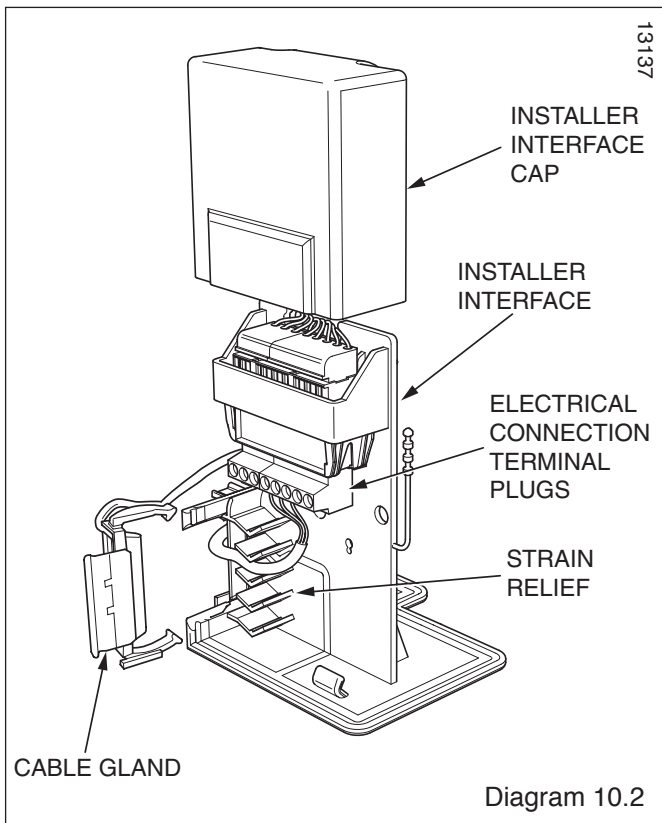
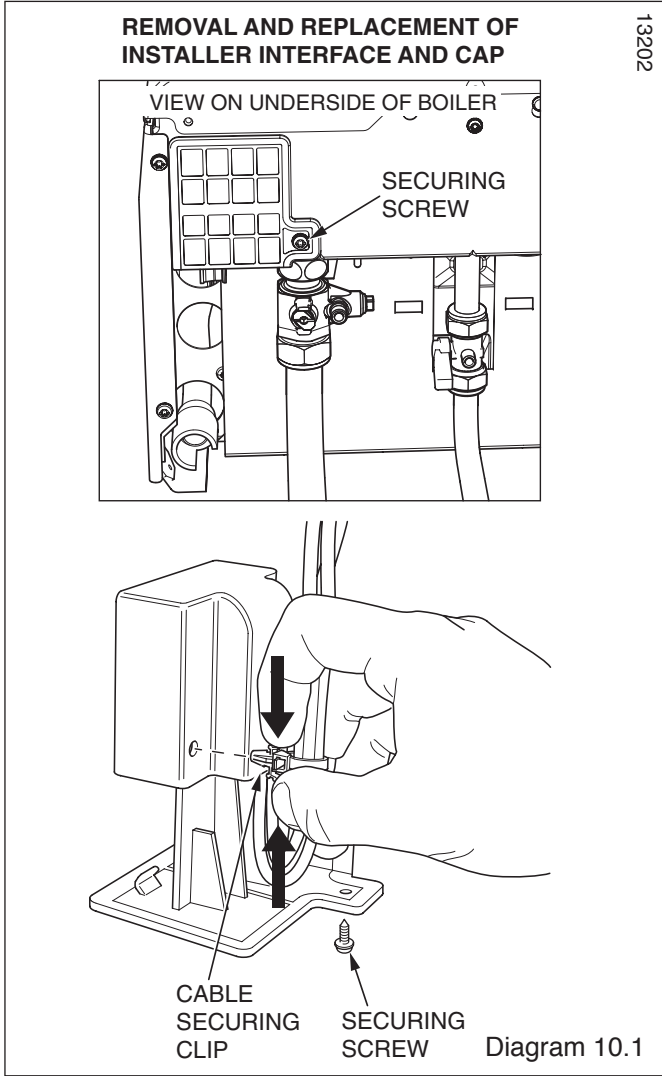

11 Commissioning

11.1 System Commissioning

Pre-filling the system

Once the system pipework has been completed it is possible to pre fill the system before mounting the boiler if so desired. Ensure that the isolation valves are securely tightened into the jig blanking plugs, see diagram 11.2.

Refer to diagram 11.1 and open the CH isolation valves 'A' by using a screwdriver or a 4mm allen key ensuring that the slot is in line with the axis of the cock (shown closed in diagram).

NOTE: A manometer kit accessory, part no. 0020016995 is available to monitor system pressure during filling if required.

This should be attached to the drain point of one of the CH isolation valves and the drain point opened to enable a reading of the system pressure to be taken.

Fill the system until a fill pressure of approximately 1.0 bar is achieved.

Vent all air from the system and repeat the filling procedure until the system is full and all air has been removed.

Check system soundness.

Close the drain point.

To comply with the water regulations the remotely installed filling loop connection must be removed.

When the appliance has been installed:

1. Open the two central heating isolating valves marked 'A' so that the slots are in line with the length of the valve (shown closed in diagram 11.1).
2. Turn the mains electricity supply on to the appliance. Set the Central Heating temperature to OFF by pressing the MODE button on the User Interface until it shows the symbol  and then pressing the - (minus) SELECTOR button. The display will now permanently show system pressure.
3. Pressurise the system until the pressure on the display reads at least 1.0bar.
4. Vent all air from the system - repeat step 3 as necessary until the system is full and all the air has been removed.

5. After filling is complete set the Central Heating temperature to the desired level using the MODE and + (plus) SELECTOR buttons as described above.

11.2 Preparation for Lighting

Isolate the boiler from the mains electrical supply.

Test for gas soundness and purge air from the gas supply. Turn on the gas isolation valve marked 'B' so that the slot is in line with the length of the valve, see diagram 11.1.

11.3 Initial Lighting

The lighting procedure of the boiler is fully automated.

Check that all external controls are calling for heat.

The digital display will show water temperature in central heating demand. The appliance will enter a self checking routine then the fan should start and the ignition will commence.

If the burner fails to light the fan will stop. Initially this may be due to air in the gas supply line. The boiler will automatically have five attempts at ignition.

If the burner fails to ignite the display will show F1.

Depress the 'reset' button on the fascia to clear the display and repeat the ignition sequence.

Set the Central heating temperature to the desired temperature by using the MODE and + (plus) or - (minus) SELECTOR buttons.

The appliance will then continue to fire in central heating mode until the user controls are satisfied.

NOTE: After ignition the boiler will ramp slowly to full rate rather than going immediately to full rate. This is an adaptive feature to cope with small system requirements.

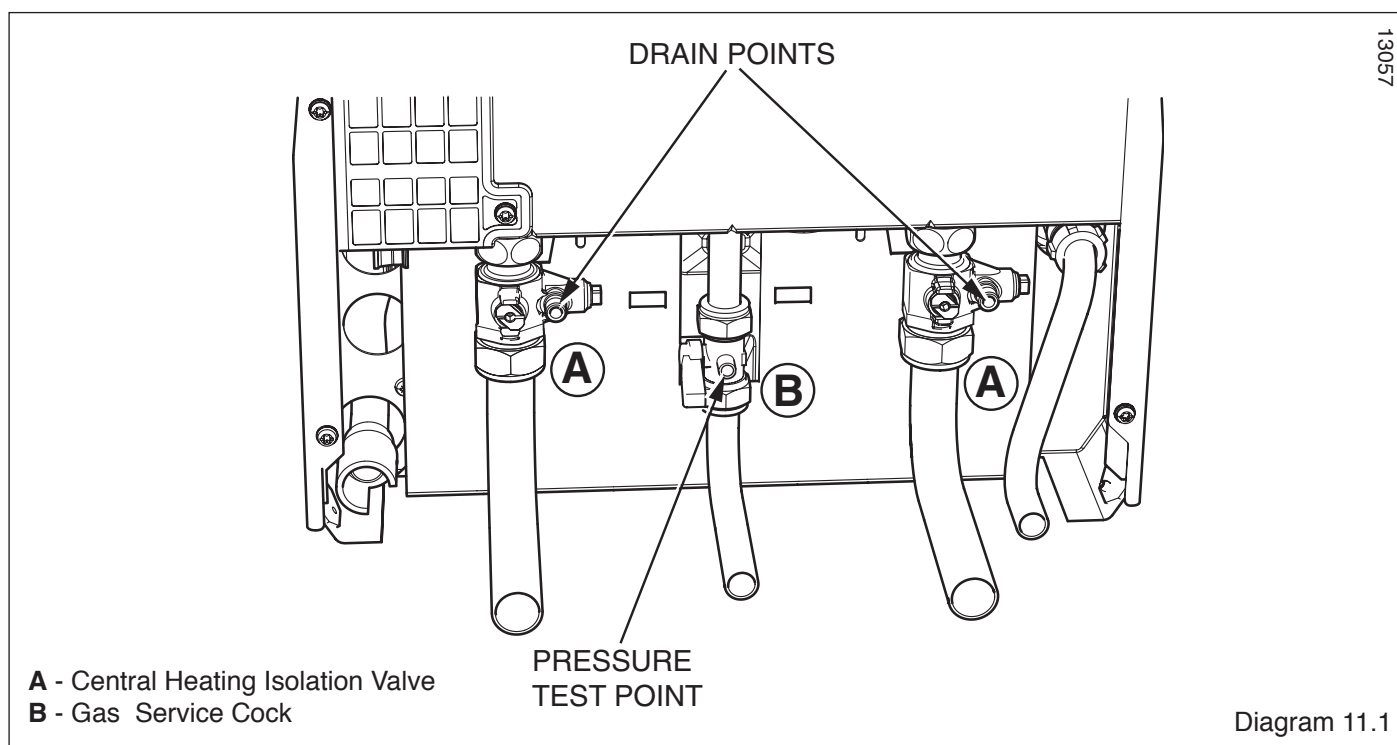

11 Commissioning

11.4 Testing

Should any doubt exist about the gas rate, check it using the gas meter test dial and stop watch at least 10 minutes after the burner has lit, making sure that all other gas burning appliances and pilot lights are off.

It should be noted that this appliance will modulate the heat input according to demand. This may affect the gas rates measured if the appliance reaches its operating temperature during the measurement.

The approximate gas rates:

18sx : 2.0m³/h (71ft³/h)

The gas valve is factory set for natural gas (G20) and should need no adjustment. It should be checked that the supply pressure is 20mbar when the boiler is firing at full rate.

In the unlikely event that the gas valve needs adjusting, refer to section 12.7. Re-setting of the gas valve requires a combustion analyser and any adjustment should only be carried out by a **competent person**.

Note that the burner pressure cannot be measured at the gas valve as it is altered by the suction of the fan and modulated according to demand.

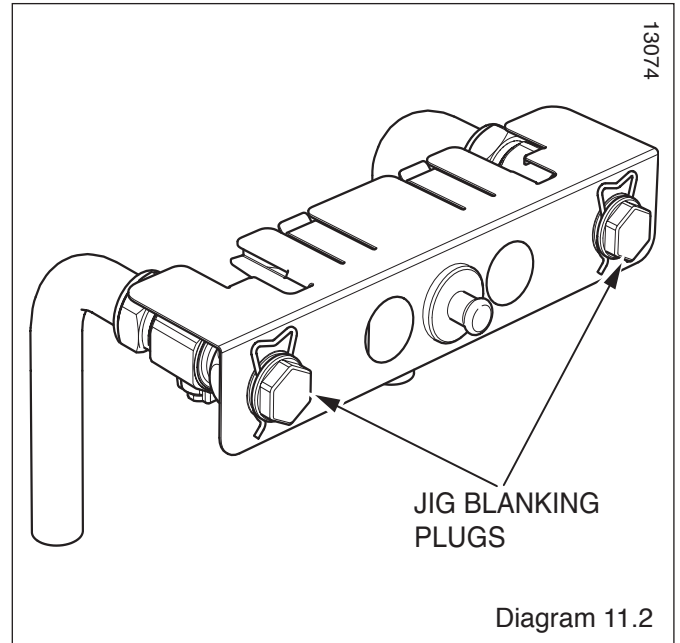

11.5 Testing - Heating System

Check that all external controls are calling for heat, the boiler will fire automatically. Fully open all radiator valves and flow control valve 'A', if fitted, see diagram 4.1.

Balance the radiators as required and if fitted adjust valve 'A' to give the required system differential. Turn off all radiators that can be shut off by the user and check to see if less than the maximum differential allowed of 20°C can be achieved across flow and return.

The pump has two speeds and can be adjusted depending on the requirements of the central heating system, see diagram 4.2.

The appliances have an inbuilt automatic adjustable bypass valve, see diagram 11.3. The pressure can be adjusted between approx 1.5 and 3.5mH₂O.

The bypass is factory pre-set to approx 2.5mH₂O. The pressure changes by approx 0.1mH₂O for each full turn of the bypass screw, see diagram 11.3. Turning clockwise increases the pressure and turning anti-clockwise decreases the pressure.

Allow the system to reach maximum temperature then switch off the boiler by isolating from the electrical supply.

Drain the entire system rapidly whilst hot, using the drain tap at the lowest part of the system. Fill and vent the system as described previously in section 11.1.

Lock or remove the handle from control valve, if fitted.

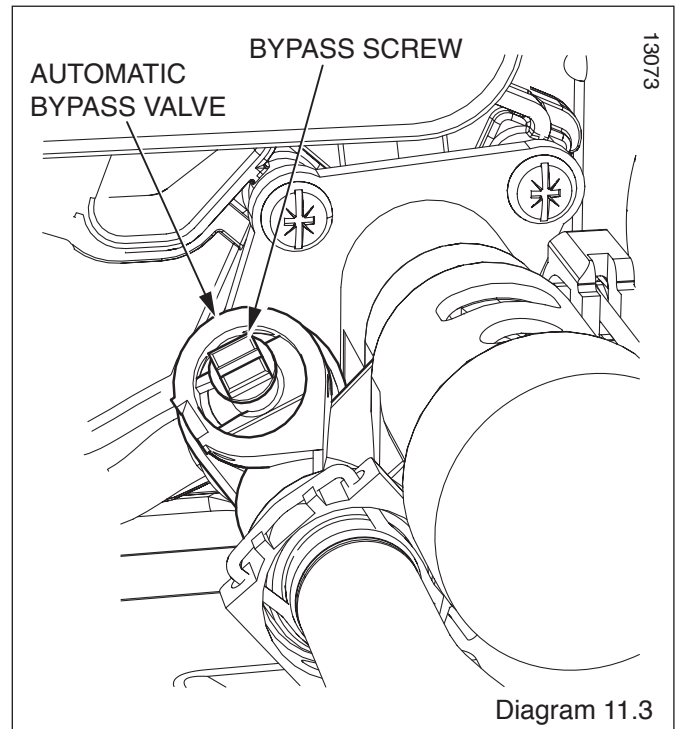

11.6 Completion

Adjust the boiler temperature control and any system controls to their required settings. In addition it is necessary to complete the "Benchmark" logbook.

For IE, it is necessary to complete a "Declaration of Conformity" to indicate compliance to I.S.813. An example of this is given in the current edition of I.S.813.

Testing Flue Gases: If any doubt exists that the flue products are not exhausting correctly, investigate by use of a gas analyser (FGA).

12 Servicing

Important Notes

To ensure the continued efficient and safe operation of the boiler it is recommended that it is checked and serviced at regular intervals. The frequency of servicing will depend upon the particular installation and usage, but in general once a year should be enough.

It is the Law that any servicing is carried out by a **competent person**.

When replacing a part on this appliance, use only spare parts that you can be assured conform to the safety and performance specification that we require. Do not use reconditioned or copy parts that have not been clearly authorised by Glow-worm.

Before commencing with a service or replacement of parts the boiler should be isolated from the electrical supply and the gas supply should be turned off at the gas service cock, see diagram 12.1.

Testing Flue Gases: If any doubt exists that the flue products are not exhausting correctly, investigate by use of a gas analyser (FGA).

Measurement of the products of combustion can be achieved by removing the front panel as described in section 12.1 and then connecting a probe to the combustion analyser test point on the flue elbow, refer Combustion Check.

IMPORTANT NOTE: Products of combustion will be discharged when the cap is removed. It is important to replace the cap immediately.

Combustion Check

A combustion check should not be necessary unless a gas carrying component has been replaced or the combustion setting is suspect.

Connect a CO₂ combustion analyser to the test point, see diagram 12.2.

Turn on the gas service cock, see diagram 12.1.

Turn on the electrical supply, the appliance will begin the ignition sequence.

A competent person only should carry out any adjustment to the gas valve, refer to diagram 12.3.

Monitor the combustion reading and at max rate the reading should be 9.3% ± 0.5.

If adjustment proves necessary then proceed as follows:

Press the “reset” button on the controls fascia, release and immediately press and hold in the “+” button. After approximately 5 seconds “Hi” will be displayed. Pressing the mode button when “Hi” is selected will force the boiler to maximum rate, the display will flash between “Hi” and the “default display” this will indicate the boiler has been forced to maximum.

Adjust the maximum rate CO₂ with the throttle to 9.3%. (Rotate anti-clockwise to increase).

To exit the check sequences press the “mode” and “+” buttons simultaneously, this will reset the boiler to the default display.

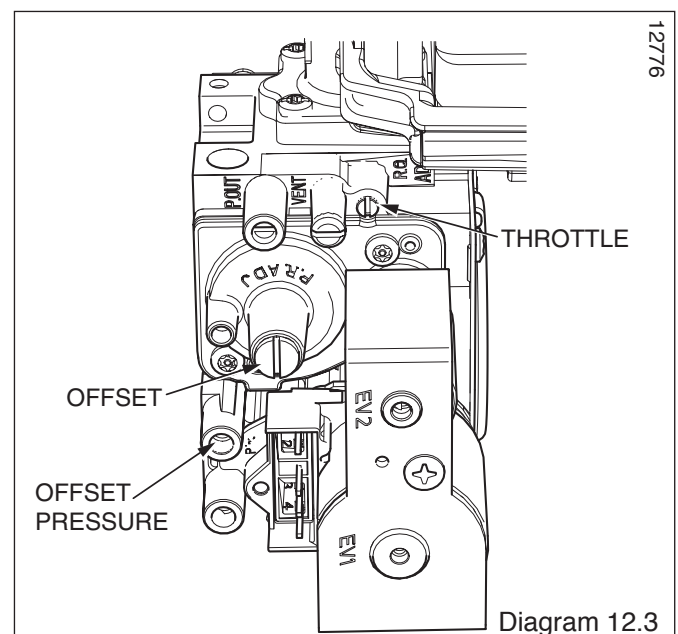
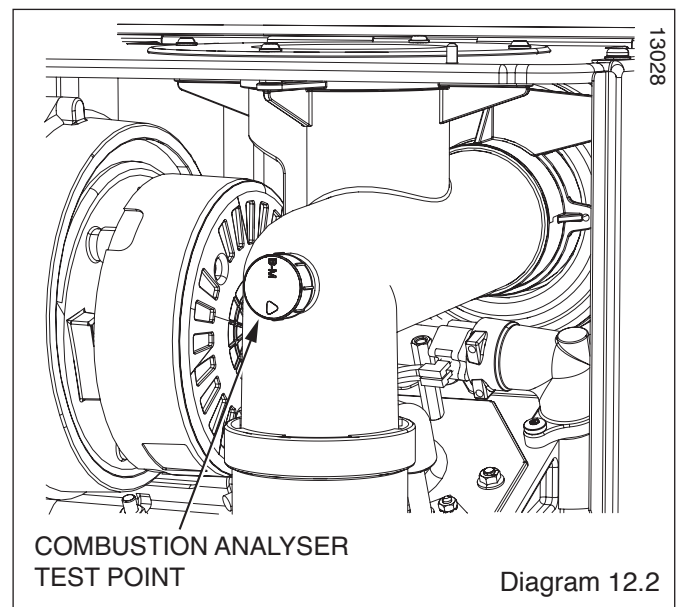
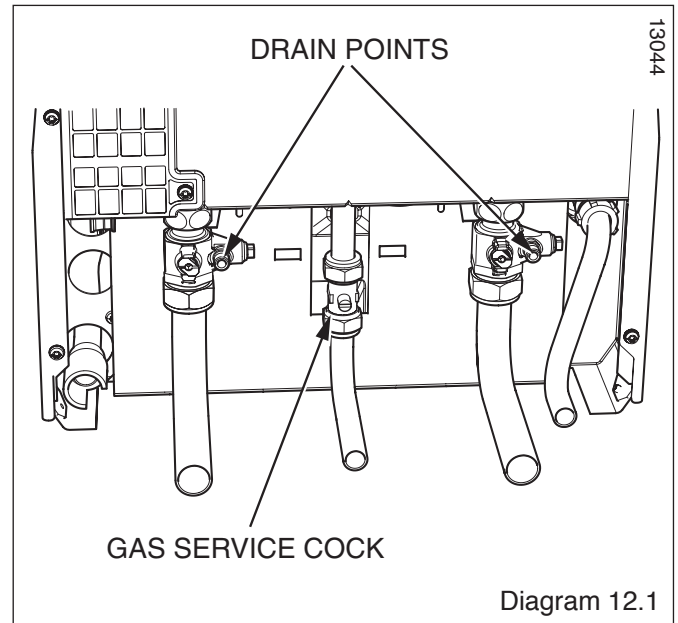

12 Servicing

Monitor the combustion reading and at min rate the reading should be $9.3\% \pm 0.5$.

If adjustment proves necessary then proceed as follows:

Press the “reset” button on the controls fascia, release and immediately press and hold in the “+” button. After approximately 5 seconds “Hi” will be displayed. Pressing the “+” or “-” buttons will cycle between “Hi” and “Lo”. Pressing the mode button when “Lo” is selected will force the boiler to minimum rate, the display will flash between “Lo” and the “default display” this will indicate the boiler has been forced to minimum.

Refer to diagram 12.3, remove the offset screw cover.

Adjustment of the CO_2 at minimum rate is very coarse so carefully adjust the CO_2 with the offset adjustment to 9.3% . (Rotate clockwise to increase).

Refit the offset cover and the cap on the test point.

To exit the check sequences press the “mode” and “+” buttons simultaneously, this will reset the boiler to the default display.

12.1 General

Removal of the front panel is required for all routine servicing. Remove the two screws on the underside of the front panel, see diagram 12.4 and lift off the retaining pins.

For access inside the appliance a Torx T20 drive is required or alternatively a flat blade screwdriver can be used.

Unless stated otherwise any part removed during servicing should be replaced in the reverse order to removal.

Servicing should always include the removal of any debris from the condensate pipe and siphon.

After completing any servicing of gas carrying components, ALWAYS test for gas soundness and carry out a functional test of the controls.

12.2 Flue Hood

Pull the flue hood securing clips away from the flue hood sump and push flue hood up slightly towards flue hood top, see diagram 12.5.

To remove swivel flue hood 90° and pull down and out towards front of boiler.

Check seal for wear or damage and replace if necessary.

IMPORTANT: Do not allow fixings, nuts, screws, etc. to fall into the open flue hood sump, use a temporary cover whilst removing any parts.

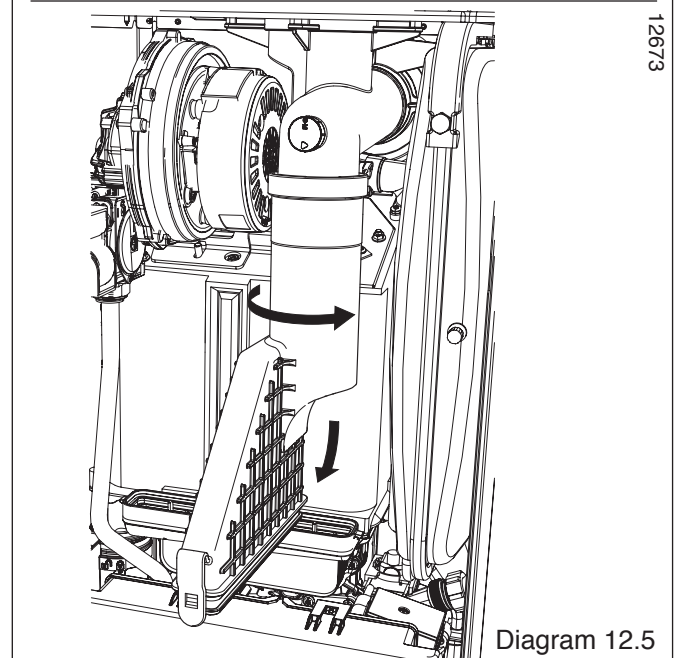
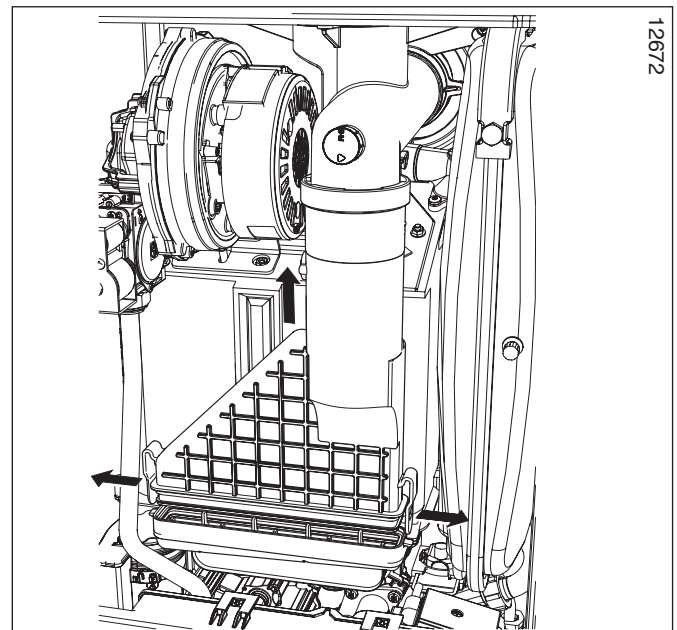
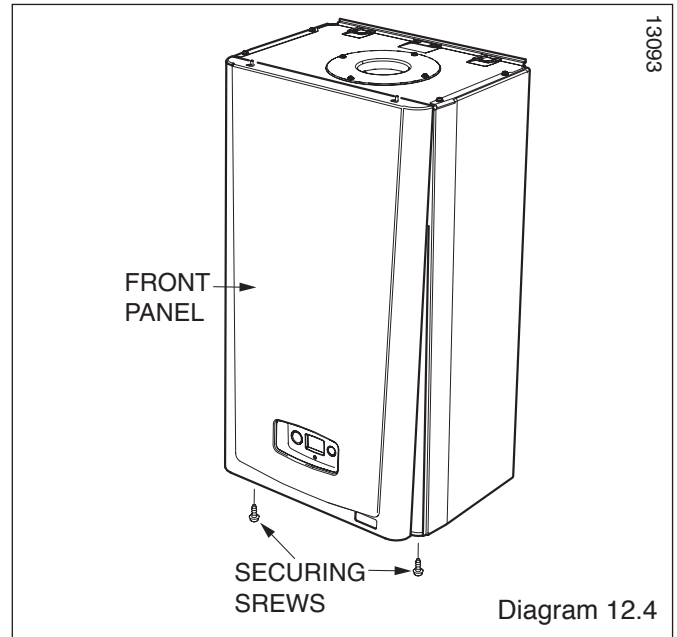

12 Servicing

12.3 Burner

Disconnect the gas supply at the gas valve and electrical connections, see diagram 12.6.

The Silencer (front) is a push fit, so there is no need for tools to remove or fit, see diagram 12.7.

Release the igniter unit support bracket, see diagram 12.8.

Remove the fan retaining bracket.
To ease removal of the securing nut from the fan retaining bracket, a flat bladed screwdriver can be used in the position shown and gently levered down as indicated, see diagram 12.9.

Remove the fan and gas valve assembly.

The silencer (rear) is a push fit so no tools are required for its removal or fitting, see diagram 12.10.

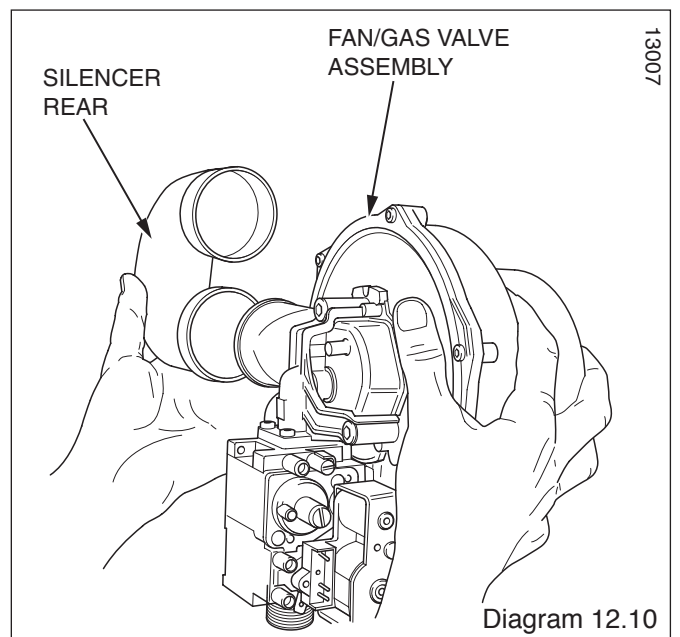
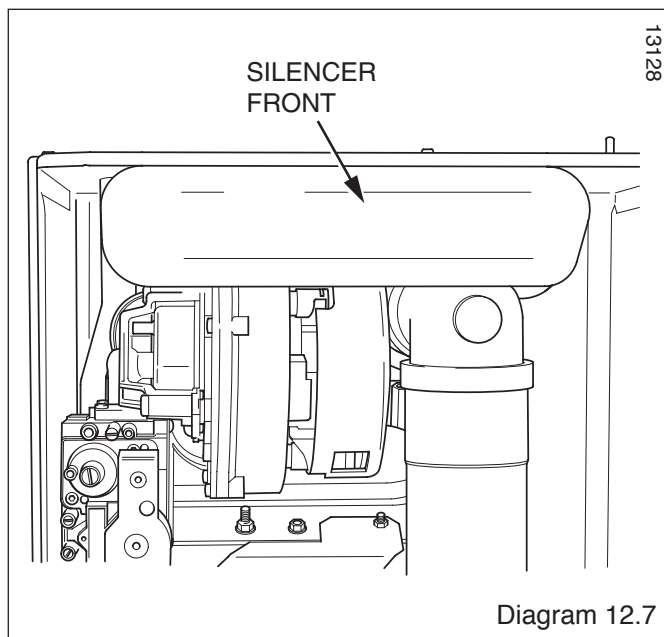
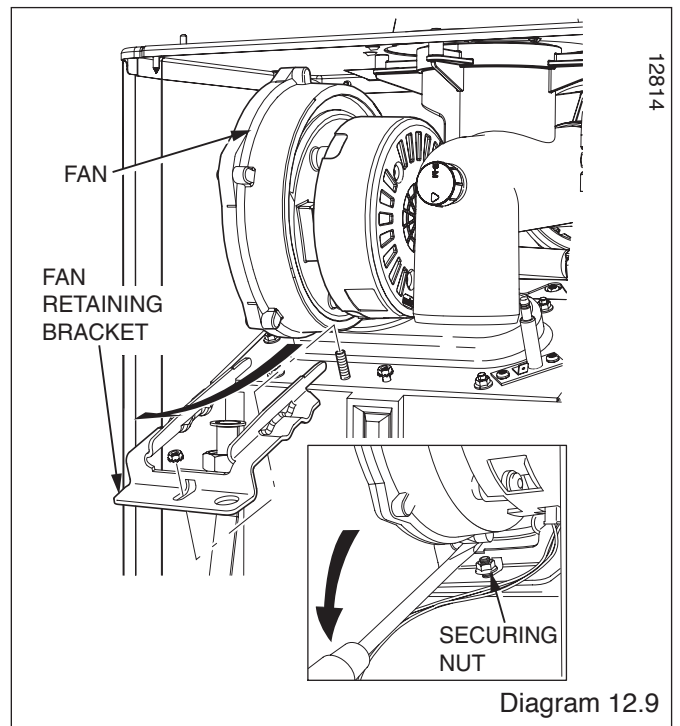
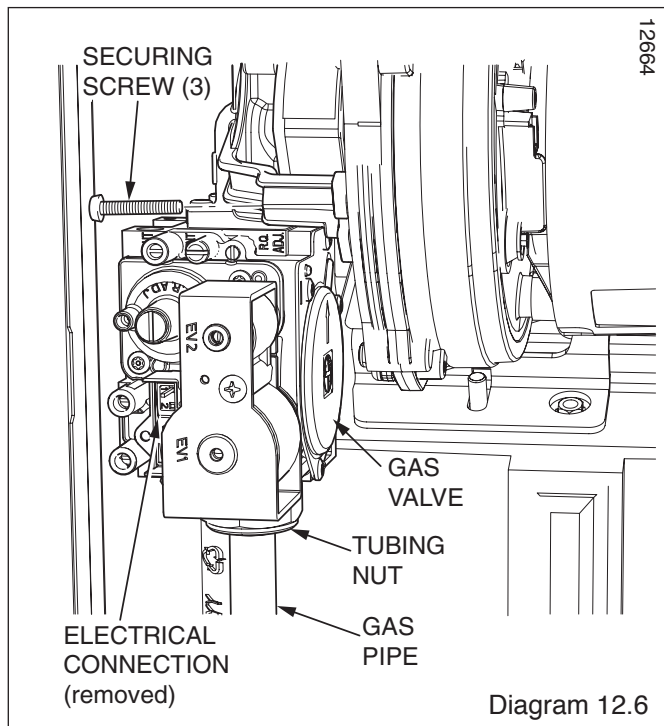
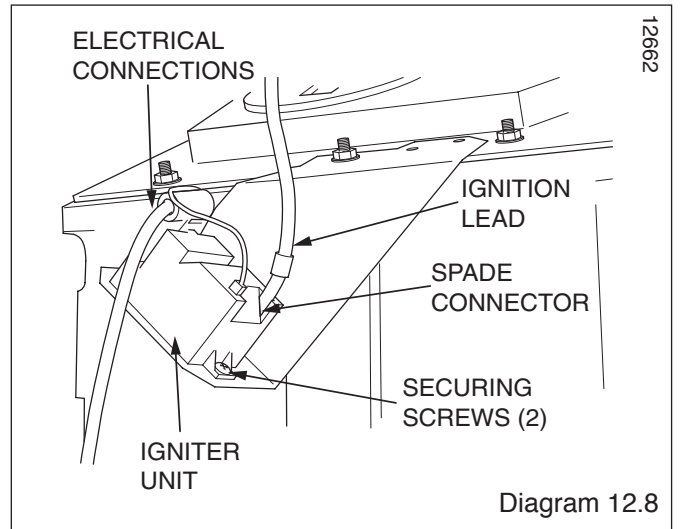

12 Servicing

Check the spark electrode gap is 4mm. Clean and adjust as necessary, diagram 12.11. It should not be necessary to remove the spark electrode from the burner during servicing.

Remove the flanged nuts and studs that secure the burner, note that two studs at the rear also hold the fan clamping bracket, see diagram 12.12.

Clean the burner with a soft brush taking great care not to damage the surface of the burner. DO NOT use wire or sharp instruments to clean the mesh of the burner.

NOTE: The burner gasket should be inspected but will not need replacing unless there are signs of wear or damage.

Follow the tightening sequence when re-fitting the burner, see diagram 12.12.

12.4 Heat Exchanger

Remove loose debris from inside the heat exchanger using a soft brush and vacuum cleaner.

Carefully flush by spraying water into the heat exchanger, any remaining debris should pass through the condensate trap (Ensure the water is kept away from electrical components).

12.5 Condensate Trap

The condensate trap does not normally need removing during servicing unless the service fill level is at full, see diagram 12.13 and section 14 for removal.

To flush the condensate drain carefully pour water into the heat exchanger and check that water flows freely to drain.

12.6 Casing panel seal check

Check the condition of the seal and replace if worn or damaged.

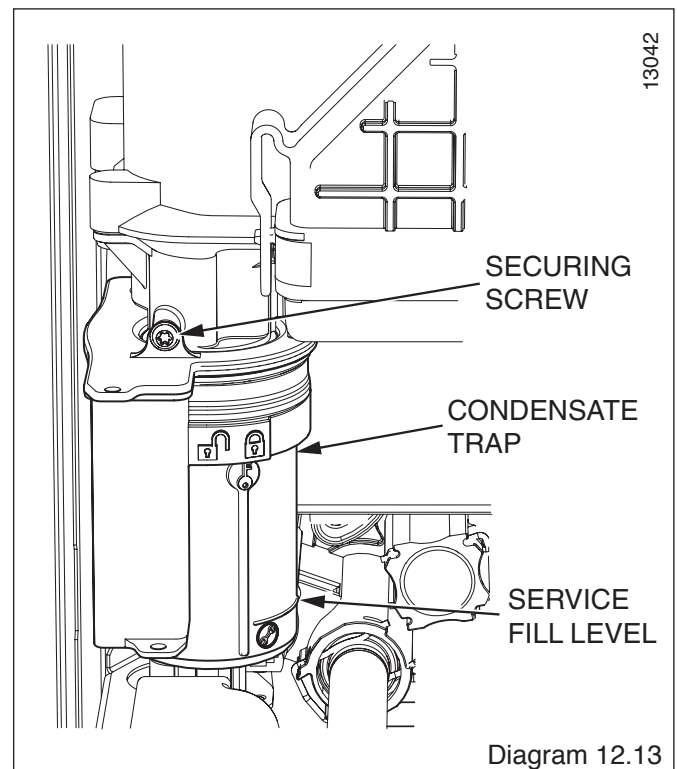
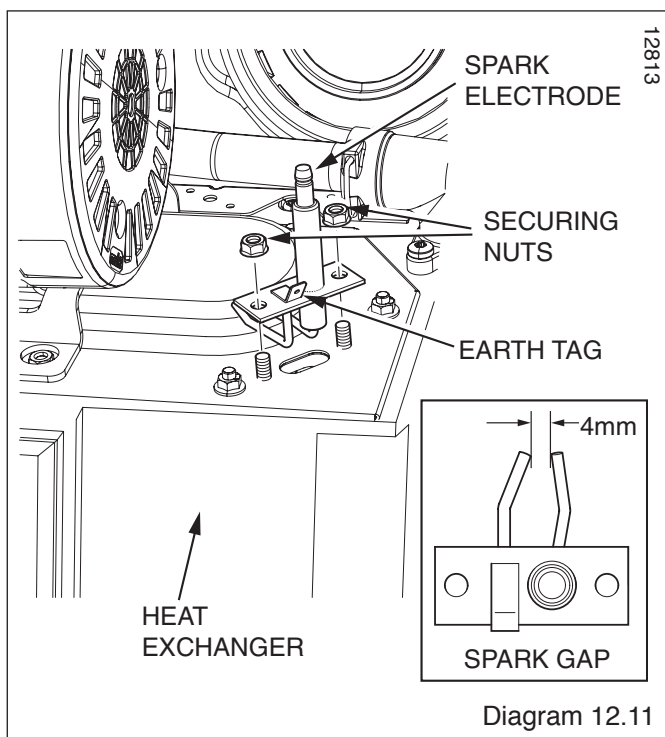
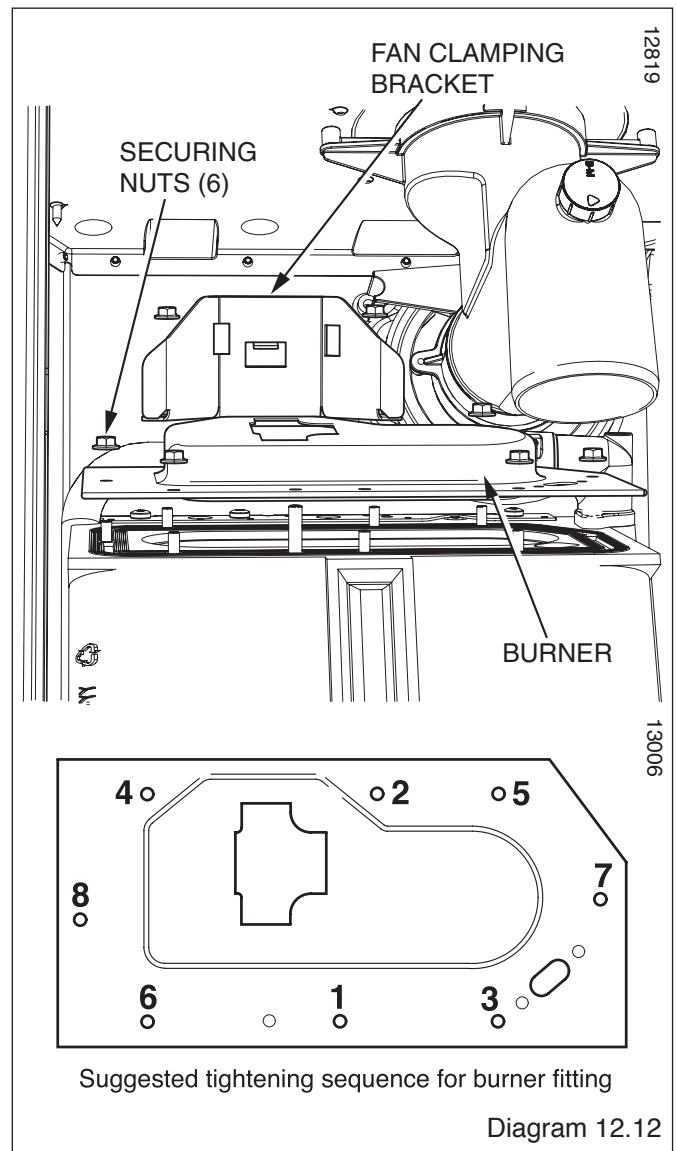

13 Fault Finding

NOTE:

Before trying to operate the boiler make sure that :

- All gas supply cocks are open and that the gas supply has been purged of air.
- There is a permanent mains supply to the boiler.
- There is a heating demand from the external controls.

WARNING

Always isolate the boiler from the electrical supply before carrying out any electrical replacement work.

Always check for gas soundness after any service work.

Electrical Testing

Should there be any doubt about the voltage supply to any of the components, it is possible to carry out a simple electrical test.

Important: On completion of the Service/Fault Finding tasks which have required the breaking and remaking of the electrical connections the earth continuity, polarity, short circuit and resistance to earth checks must be repeated using a suitable multimeter.

To carry out the electrical test, gain access, as follows:
Hinge down the control box and unclip the rear cover to gain access. Refer to the wiring diagram 13.1 and fault finding charts, diagrams 13.2 to 13.6.

13 Fault Finding

13050

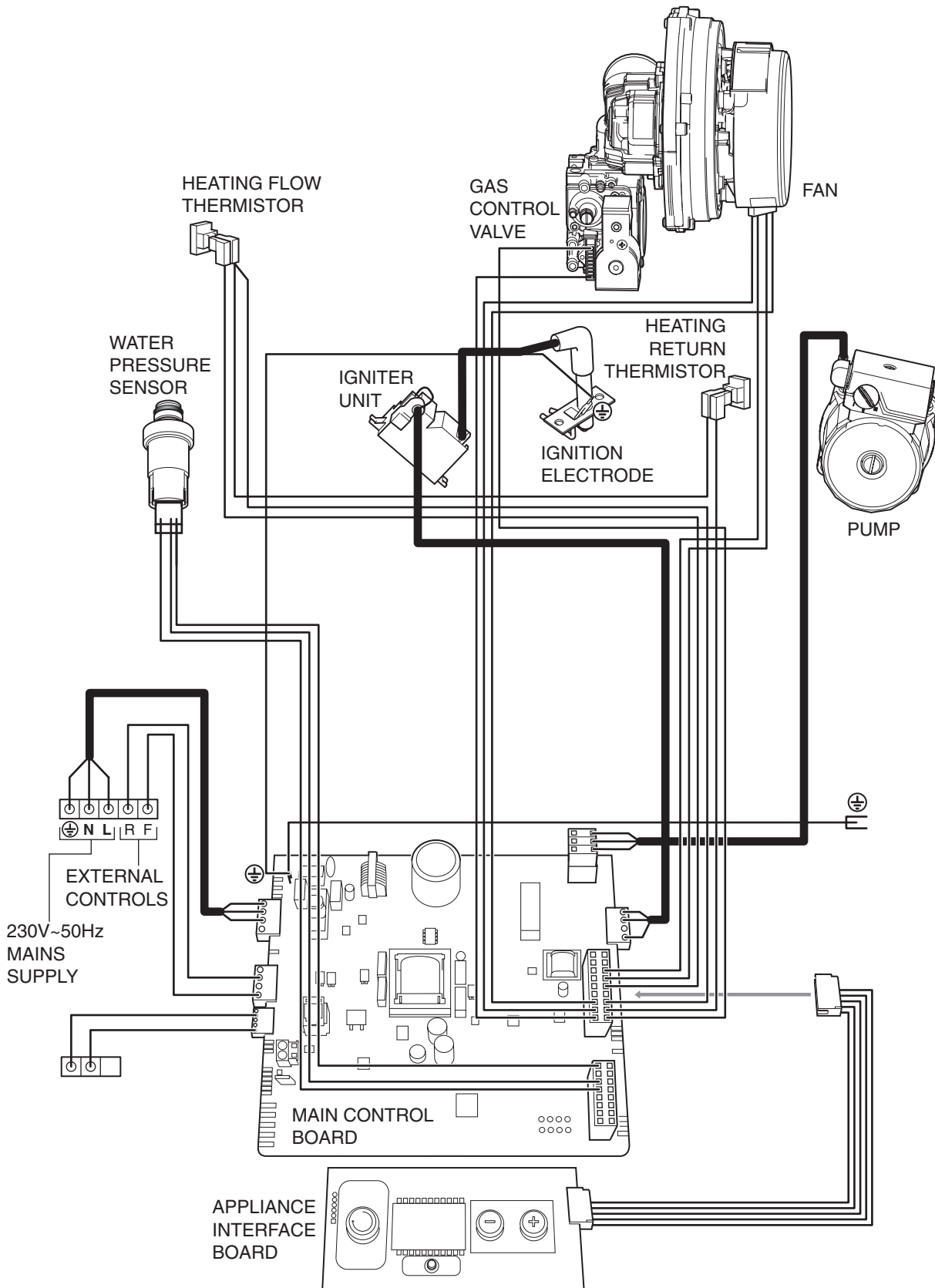

Diagram 13.1

13 Fault Finding

13012

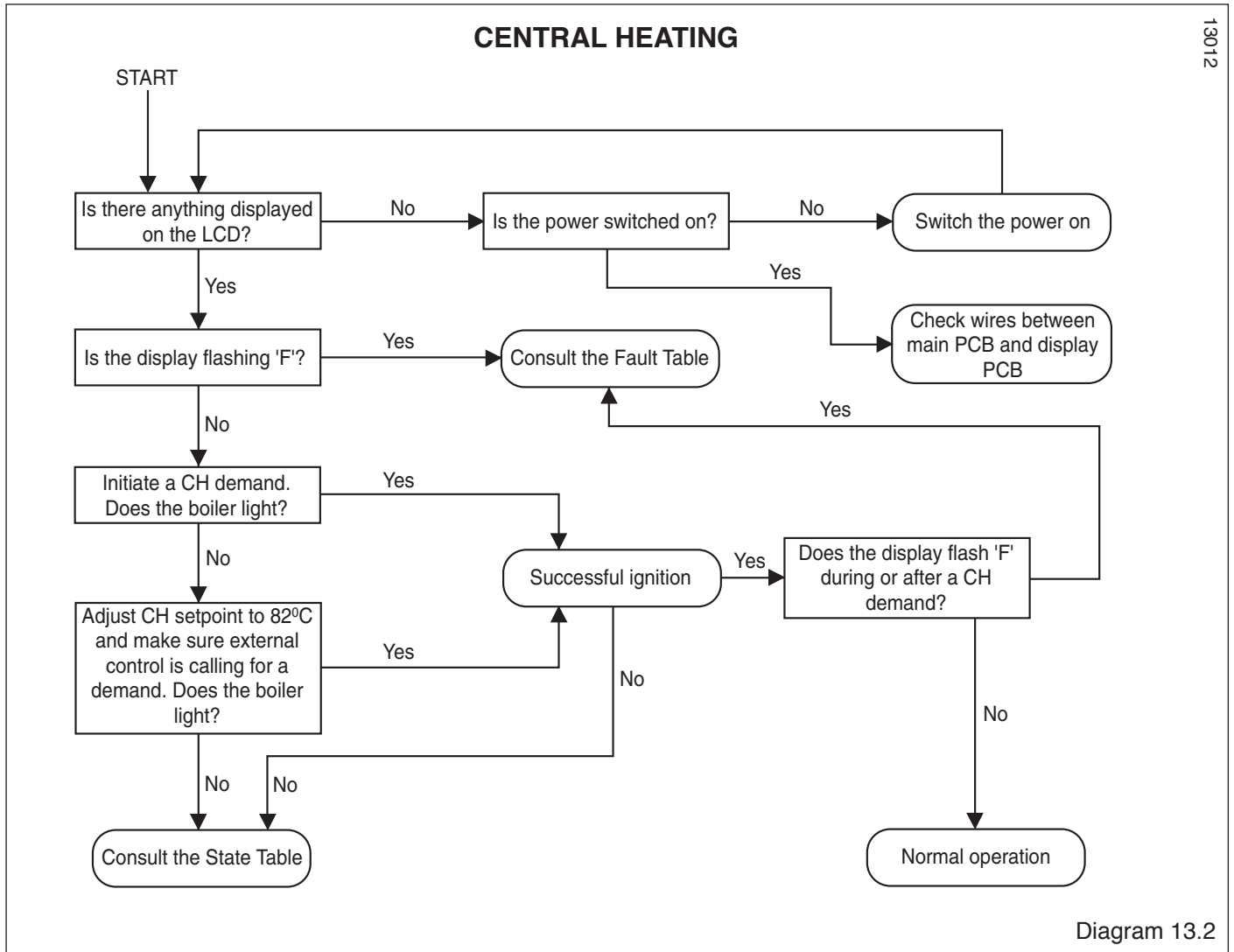

Diagram 13.2

13 Fault Finding

13010

CODE	DESCRIPTION	POSSIBLE CAUSE
F1	Boiler has attempted to light 5 times and failed on all occasions	Gas tap is closed. Gas valve connector is loose, unconnected, faulty, or wires are trapped. Ignitor connectors are loose, unconnected, faulty, trapped. Faulty Ignitor. Low gas inlet pressure. Incorrect gas valve adjustment. Electrode Ignition leads loose, unconnected, faulty, trapped. Electrode broken, defective, or position incorrect. Air inlet blocked, flue inlet blocked, flue duct leaking. Earthing connection loose, disconnected.
F4	Flame goes out whilst lit during a demand	Gas tap is closed. Gas valve connector is loose, unconnected, faulty, or wires are trapped. Ignitor connectors are loose, unconnected, faulty, trapped. Faulty Ignitor. Low gas inlet pressure. Incorrect gas valve adjustment. Electrode Ignition leads loose, unconnected, faulty, trapped. Electrode broken, defective, or position incorrect. Air inlet blocked, flue inlet blocked, flue duct leaking. Earthing connection loose, disconnected.
F5	Overheat in S/W	Boiler has overheated – press reset button
F6	Central Heating Flow Thermistor connection fault	Thermistor wires unconnected, faulty, trapped.
F9	Pressure	Water pressure Connector loose, unconnected, faulty or wires trapped. Water Pressure Sensor Faulty Pump ceased, faulty. No water in the system
F10	Central Heating Return Thermistor connection fault	Thermistor wires unconnected, faulty, trapped.
F13	PCB Memory or sensing fault	Loose connections on Main PCB or display PCB. Central Heating Flow or Return Thermistor wires unconnected, faulty, trapped. Electrode Ignition leads loose, unconnected, faulty, trapped. Earthing connection loose, disconnected.
F22	Low Water pressure or Ignition temperature rise too slow	Not enough water in the system. Central Heating Flow or Return Thermistor wires loose, faulty, trapped. Central Heating Flow or Return Thermistor not connected to pipe correctly Air in the system. Faulty pump or pump speed too fast.
F25	Central Heating Flow temperature rise too high during operation. Central Heating Return temperature rise or temperature difference too high during operation. Central Heating Temperature difference (between Flow and Return) too high during operation.	Check thermistors are connected to pipes correctly. Air in the system. System is too restrictive.
F43	Generic error	Check all electrical connections - internal & external
F70	Software incompatible	Telephone Group Service

NO DISPLAY - Check connection from display PCB to main PCB connector X51

Diagram 13.3

13 Fault Finding

13135

State list - To access the state lists the '-' button must be pressed for longer than 5 seconds until it begins to flash 'S' and then a number to indicate the state. The state numbers are given below.

STATE LISTS

	Central heating mode	Possible Causes
S.00	no heating required	
S.01	fan pre-run	
S.02	pump pre-run	
S.03	ignition	
S.04	burner on	
S.05	pump / fan overrun	
S.06	fan overrun	
S.07	pump overrun	
S.08	Anti cycling period	
	Special cases of status messages	
S.30	No Heating demand from external controls 230V	Check wiring in external controller. Check wiring at Installer Interface.
S.31	summer mode	Check CH setpoint / Check external controls
S.32	Antifreeze active – fan speed variation too high – waiting during blocking function	Check fan connection.
S.34	frost protection active (Priority 4)	Temperature below 8°C - check thermistor connection if this is not true.
S.36	No Heating demand from external controls 24V	Check wiring in external controller. Check wiring at Installer Interface.
S.42	Accessory Module is blocking burner operation	Check accessory module.
S.53	waiting time: temperature difference flow - return sensor too high (Check thermistor fit)	Check flow & return thermistor connections to pipes. Check harness connection to thermistor. Check harness wires are not trapped between any internal components.
S.54	waiting time: no water in system, temperature (gradient error) rise flow / return sensor too high	Check flow & return thermistor connections to pipes. Check harness connection to thermistor. Check harness wires are not trapped between any internal components.
S.76	Waiting period – pressure sensor	Check system pressure - default display.
S.96	Return-Sensor check is running, demand (DHW or heating) is blocked	Check return thermistor connection to pipe. Check harness connection to thermistor.
S.97	Water pressure sensor check is running, demand (DHW or heating) is blocked	Check connection to pressure sensor. Check pump has not seized.
S.98	Flow / Return - sensor check is running, demand (DHW or heating) is blocked	Check flow & return thermistor connections to pipes. Check harness connection to thermistor. Check harness wires are not trapped between any internal components.

Diagram 13.4

13 Fault Finding

To enter the diagnostics menu follow the procedure below:-

Press and hold the '↶' and '+' buttons for approx 5 seconds until the screen changes. Use the '+' or '-' button to select the number 96, this is the password. Hold the '↶' for approx 5 seconds when 96 is selected, when the screen changes release the button. The screen will flash between 'L1' and a number. 'L1' indicates you have level 1 access, the number indicates the diagnostic number below. Use the '+' and '-' to cycle through the selections below. To select a diagnostic number press the '↶' button when the correct number is selected. The display will show the parameter value of the diagnostic number selected. To return to the diagnostic number selector simply press the '↶' button. To change the parameter use the + or - buttons. Once the value has been changed it must be saved by holding the '↶' button for approximately 5 seconds. This will return to the diagnostic number selector.

DIAGNOSTIC CODES - LEVEL 1

Installer Access

Display	Meaning	
d.00	Heating part load	Adjustable heating part load in kW (factory setting: max. output)
d.01	Water pump over run time for heating mode	2 - 60 min (factory setting: 5 min)
d.02	Max. burner anti cycling period at 20°C Flow temperature	3 - 60 min (factory setting: 20 min)
d.04	N/A	N/A
d.05	Flow temperature setpoint	In °C, min. 38 and max. 82
d.06	Domestic hot water setpoint	In °C, 40 to 60°C
d.07	N/A	N/A
d.08	External controls heat demand (Clamp 3-4)	0= no heat request (open) 1 = heat request (closed)
d.09	Flow target temperature from external analogue regulator to terminal 7 R	In °C, minimum from ext. eBUS target value and target value terminal 7
d.10	Status internal heating pump	1,2 = on, 0 = off
d.11	Status external heating pump	1 to 100 = on, 0 = off
d.13	Hot water circulation pump (via accessory module)	1 to 100 = on, 0 = off
d.23	Summer/Winter function	1 = Winter, 0 = Summer
d.25	Hot water activation via eBUS Control	1 = yes, 0 = no
d.33	Fan speed target value	in rpm/100
d.34	Fan speed actual value	in rpm/100
d.40	Flow temperature	Actual value in °C
d.41	Return temperature	Actual value in °C
d.44	Ionisation current	Actual value (10nA)
d.47	N/A	N/A
d.60	Number of safety temperature limiter cut offs	Quantity
d.61	Number of lock outs	Number of unsuccessful ignitions in the last attempt
d.64	Average ignition time	In seconds
d.65	Maximum ignition time	In seconds
d.68	Unsuccessful ignitions in the first attempt	Quantity
d.67	Remaining burner anti cycling time (block time)	Quantity
d.69	Unsuccessful ignitions in the second attempt	Quantity
d.76	Appliance variant (device specific number)	00 to 99
d.80	Heating operating hours	in h
d.82	Cycles in heating mode	Quantity
d.83	Cycles in hot water operation	Quantity
d.84	Maintenance indicator: Number of hours until next maintenance	Quantity
d.90	Digital regulator status	1 = identified, 0 = unidentified (eBUS Address <= 1 0)

13136

Diagram 13.5

14 Replacement of Parts

14.1 General

Replacement of parts must be carried out by a **competent person**.

Before replacing any parts the boiler should be isolated from the mains electric supply and the gas should be turned off at the service cock on the boiler, see diagram 14.1.

Ensure that components with electrical connections are disconnected before removal.

Unless stated otherwise parts are replaced in the reverse order to removal.

After replacing any parts always test for gas soundness and if necessary carry out functional test of the controls.

For replacement of parts the front casing of the boiler will need to be removed. To remove undo the two screws on the underside of the front casing and lift off.

14.2 Draining of Boiler Heating Circuit

Drain down the Heating Circuit of the boiler only, by closing the heating flow and return isolating valves on the wall mounting jig.

Attach a length of hose to the drain point and open the drain valve, see diagram 14.1.

Check for leaks.

14.3 Igniter Unit

For access, refer to section 14.1.

Remove ignition lead and electrical connections then remove igniter unit by removing two securing screws, see diagram 12.8.

14.4 Ignition Lead

For access, refer to section 14.1.

Pull the spark plug style connector off the spark electrode and the spade connector connected to the igniter unit, see diagram 12.8.

14.5 Silencer Assembly (front)

For access, refer to section 14.1.

Pull forwards to remove.

The silencer is a push fit so no tools or fixings are required for its removal or fitting, see diagram 12.7.

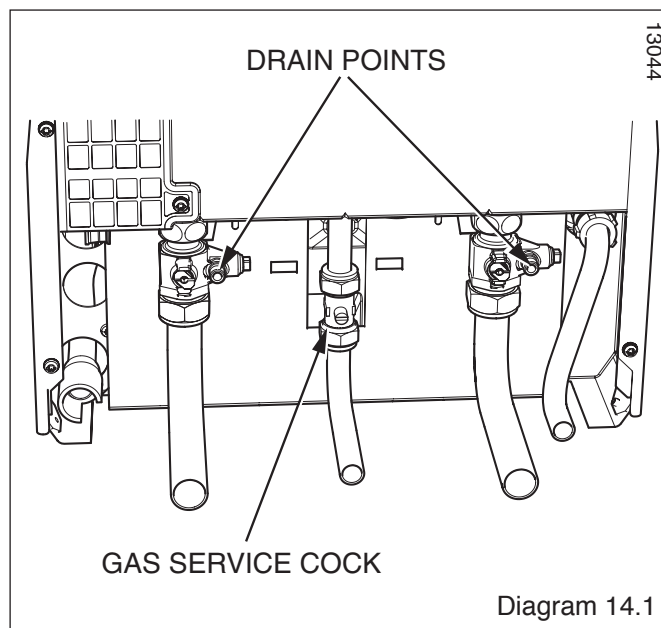

14 Replacement of Parts

14.6 Gas Valve

For access, refer to section 14.1.

Remove the electrical plug from the gas valve.

Undo the tubing nut holding the gas pipe to the gas valve. Remove the three securing screws, holding the gas valve to the fan and remove the gas valve, see diagram 12.6.

After re-fitting check the combustion CO_2 and adjust if necessary, refer to section 12, Combustion Check.

After assembly test for gas soundness and purge in accordance with the current issue of BS6891 or in IE, the current edition of I.S.813 "Domestic Gas Installations".

14.7 Flue Hood

For access, refer to section 14.1.

Pull the flue hood securing clips away from the flue hood sump and push flue hood up slightly towards flue hood top, see diagram 12.5.

To remove swivel flue hood 90° and pull down and out towards front of boiler, see diagram 14.5.

14.8 Fan

For access, refer to section 14.1.

Remove the gas valve as described in the relevant parts of section 14.6.

Remove the securing nut holding the fan retaining bracket, lift front of bracket away from stud and pull forward to release the fan, see diagram 12.9, check and replace any seals or gaskets if necessary.

14.9 Expansion Vessel

For access, refer to section 14.1.

Drain the boiler heating circuit, refer to section 14.2.

Undo the coupling at the base of the vessel, see diagram 14.2.

Remove the locking screw and spacer from the retaining bracket at the top of the expansion vessel. Whilst holding and also pushing down slightly on the vessel, remove the expansion vessel retaining bracket by unhooking and sliding forward.

The expansion vessel can now be removed by sliding it forward clear of its support guides.

When re-fitting a new gasket will be required between the expansion vessel and coupling.

Refill, vent and pressurise the boiler.

Check for leaks.

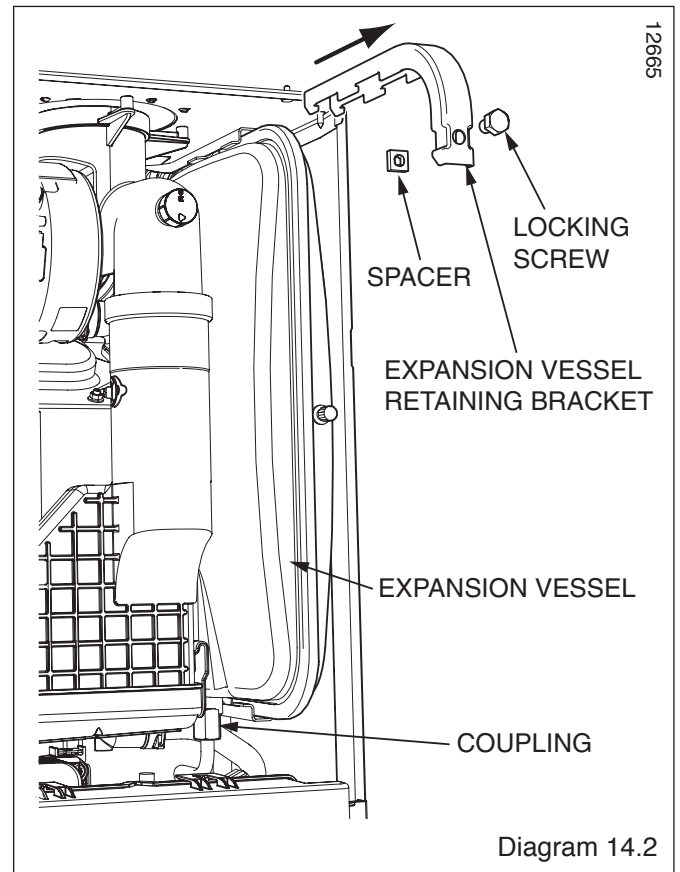

Diagram 14.2

14 Replacement of Parts

14.10 Fan/Gas valve assembly

For access, refer to section 14.1.

Undo the tubing nut to remove the gas valve from the gas pipe and any electrical connections, see diagram 12.6.

Remove the securing nut holding the fan retaining bracket, press down on burner to ease removal of securing nut. Slide out the fan retaining bracket.

Lift front of bracket away from stud and pull forward to release the fan, see diagram 12.9.

Lift fan/gas valve assembly up and forward away from locating studs.

Remove fan gasket and replace if necessary.

To replace the fan and retaining bracket correctly, insert into slots on fan clamping bracket, see diagram 12.12, and locate onto lugs on the burner.

14.11 Silencer assembly (rear)

For access, refer to section 14.1.

Remove the fan/gas valve assembly, see relevant sections.

Pull Silencer rear away from fan/gas valve assembly.

The rear silencer is a push fit so no tools or fixings are required for its removal or fitting, see diagram 12.10.

14.12 Spark Electrode

For access, refer to section 14.1.

Remove the spark plug lead and earth lead.

Remove the two securing nuts, see diagram 12.11.

Withdraw the spark electrode by slowly pulling up and leaning it forward towards the centre of the heat exchanger to ensure that the electrode does not foul on the hole in the burner casing.

Check spark gap.

14.13 Burner

For access, refer to section 14.1.

Remove igniter unit, flue hood, fan and gas valve assembly and spark electrode lead, refer to relevant sections.

Remove the flanged nuts and studs that secure the burner, note that two studs at the rear also hold the fan clamping bracket, see diagram 14.10.

NOTE: The burner gasket should be inspected but will not need replacing unless there are signs of wear or damage.

IMPORTANT: Do not allow fixings, nuts, screws, etc. to fall into the open flue hood sump, use a temporary cover whilst removing any parts.

14 Replacement of Parts

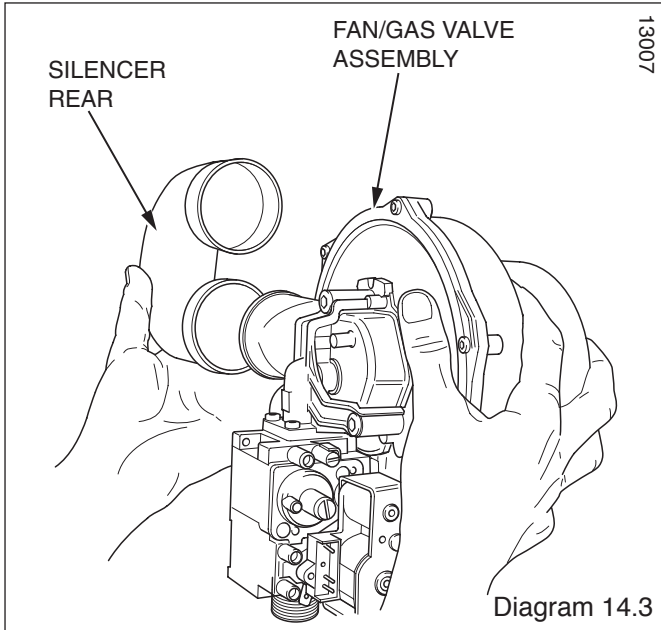

14.14 Condensate Trap

For access, refer to section 14.1.

Remove the drain outlet pipe from the base of the trap. Remove the condensate drain securing screw and carefully pull the trap forward, see diagram 12.13.

On the condensate trap there is a key symbol that should be in line with the locked padlock symbol on the condensate drain. To remove the trap turn in the direction of the unlock symbol and carefully pull down clear of the condensate drain, see diagram 12.13.

Remove any solids found in the condensate trap.

Flush water through the trap to remove any remaining solids. Check for any debris in the outlet pipe of the condensate drain and clean as necessary.

Reassemble and refit the condensate trap.

14.15 Heating Flow Thermistor

For access refer to section 14.1.

Remove the silencer front, fan/gas valve assembly and flue hood for access. See relevant sections.

Refer to diagram 14.4.

Remove the electrical connections from the thermistor.

Remove the retaining clip from the flow pipe.

Remove the thermistor from the retaining clip.

Note that the polarity of the wiring to thermistors is unimportant.

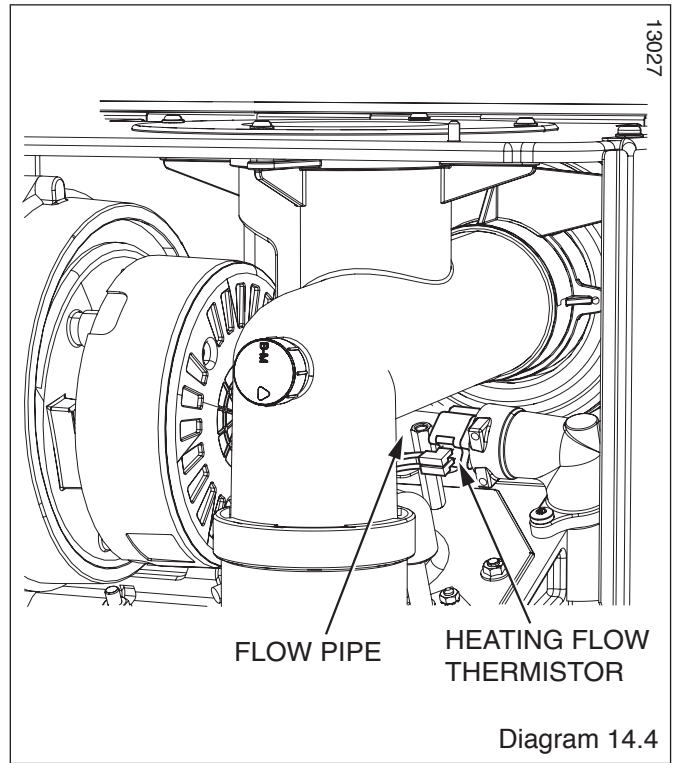

Diagram 14.4

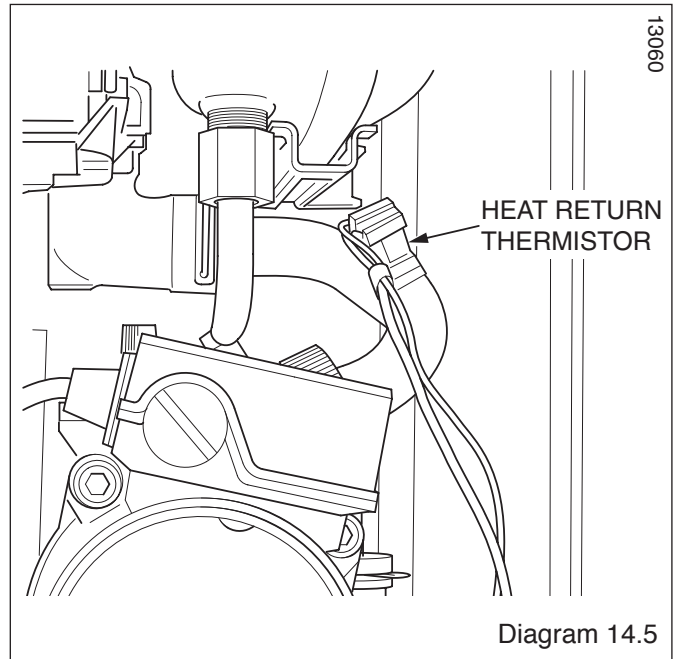

Diagram 14.5

14.16 Heating Return Thermistor

For access, refer to section 14.1.

Refer to diagram 14.5.

Remove the electrical connections from the thermistor.

Remove the retaining clip from the return pipe.

Remove the thermistor from the retaining clip.

Note that the polarity of the wiring to thermistor is unimportant.

14 Replacement of Parts

14.17 Pump (head only)

For access, refer to section 14.1.

Refer to section 14.2 and drain the boiler heating circuit.

Refer to diagram 14.6.

Remove the four cap head screws.

Carefully remove the pump head together with cable. Do not strain cable.

Support the pump head, unscrew cable cover at the side of pump head and remove.

Disconnect wiring from pump head.

Reconnect wiring to new pump head and fit cover.

Fit the new pump head with 'O' ring.

Refill, vent and pressurise the boiler and check for leaks.

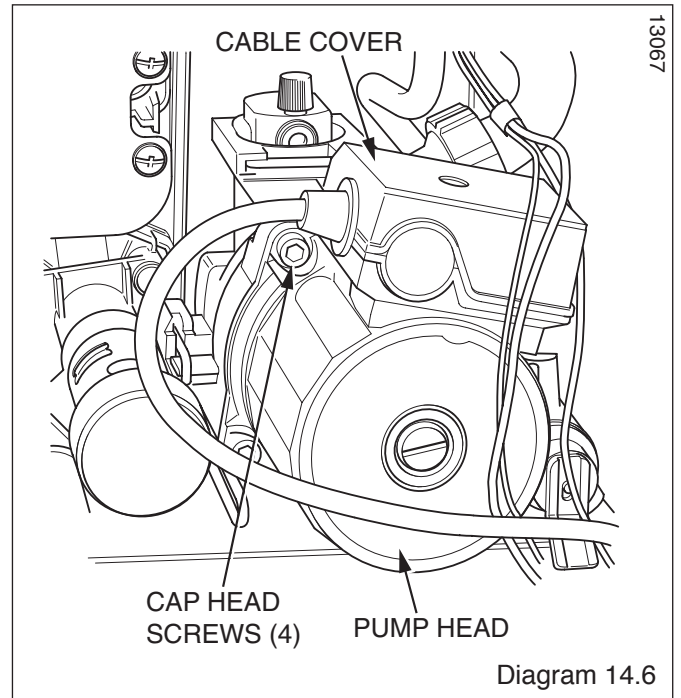

14.18 Safety Discharge Valve

For access, refer to section 14.1.

Refer to section 14.2 and drain the boiler heating circuit.

Refer to diagram 14.7.

Undo the safety discharge valve union and remove from the pipework.

Remove the retaining clip and withdraw the safety discharge valve.

Fit new 'O' ring.

Refill, vent and pressurise the boiler and check for leaks.

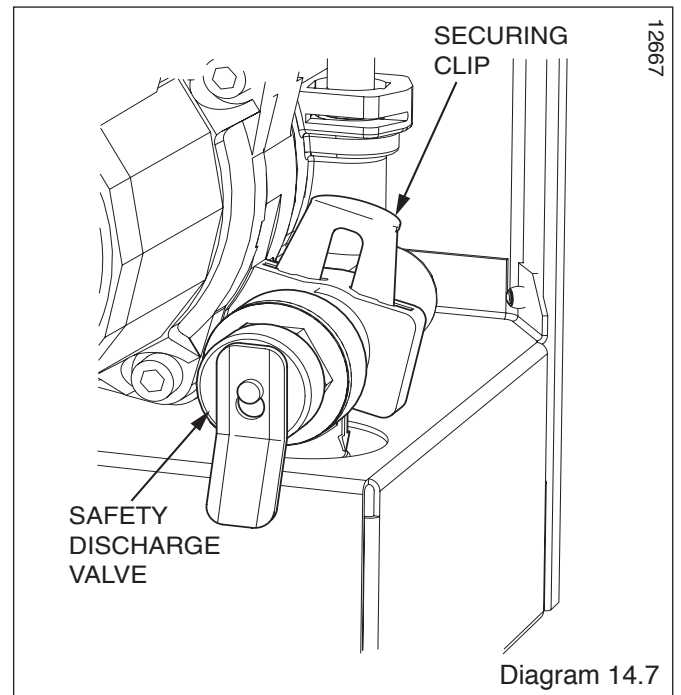

14 Replacement of Parts

14.19 Automatic Air Vent

For access, refer to section 14.1.

Refer to section 14.2 and drain the boiler heating circuit.

Refer to diagram 14.8.

Remove the retaining clip to release the automatic air vent.

Fit the new automatic air vent and 'O' ring ensuring the vent cap is left loose.

Refill, vent and pressurise the boiler and check for leaks.

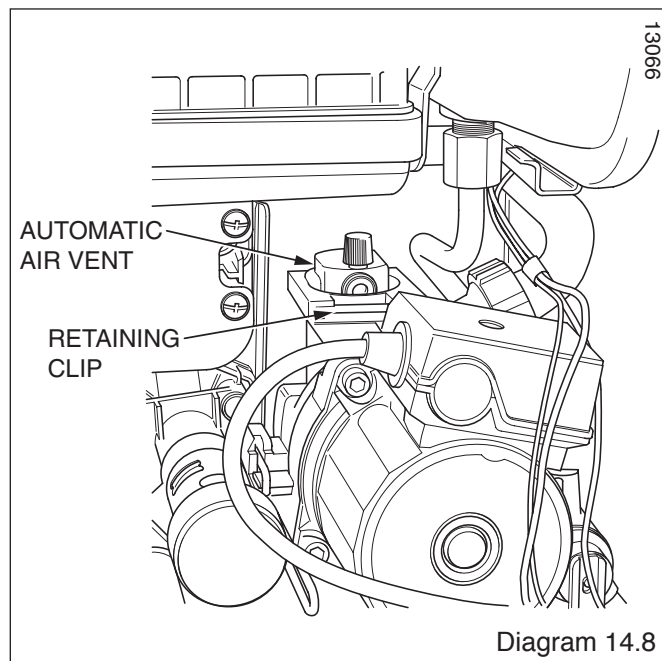

14.20 Heat Exchanger

For access, refer to section 14.1.

Remove silencer front, flue hood, gas valve / burner assembly, spark electrode lead, burner and condense trap.

Refer to section 14.2 and drain the boiler heating circuit.

Remove the retaining clip from the flexible hose connection into the brass elbow on the lower left hand side of the heat exchanger. Detach the flexible hose.

Remove screws securing the heat exchanger, one on top and one underneath the heat exchanger, see diagram 14.9.

Undo the knurled nut at the right hand side of the hydroblock. Remove the retaining clip from the flanged elbow at the right hand bottom of the heat exchanger. Remove the flow pipe.

Lift up heat exchanger slightly to disengage it from its hanging bracket.

Remove the heat exchanger by pulling forward and tilting backwards to ease removal complete with sump, return pipe and flanged elbows.

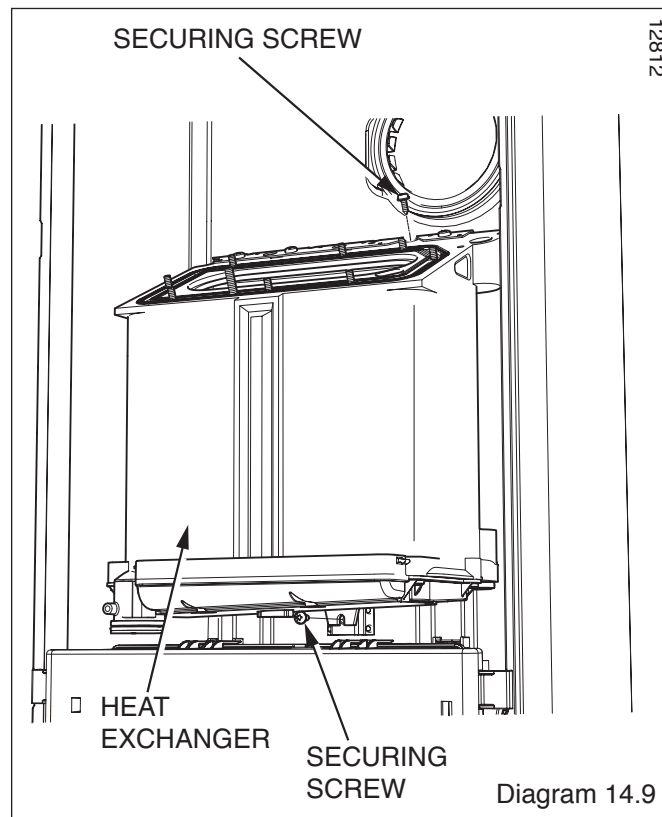

14 Replacement of Parts

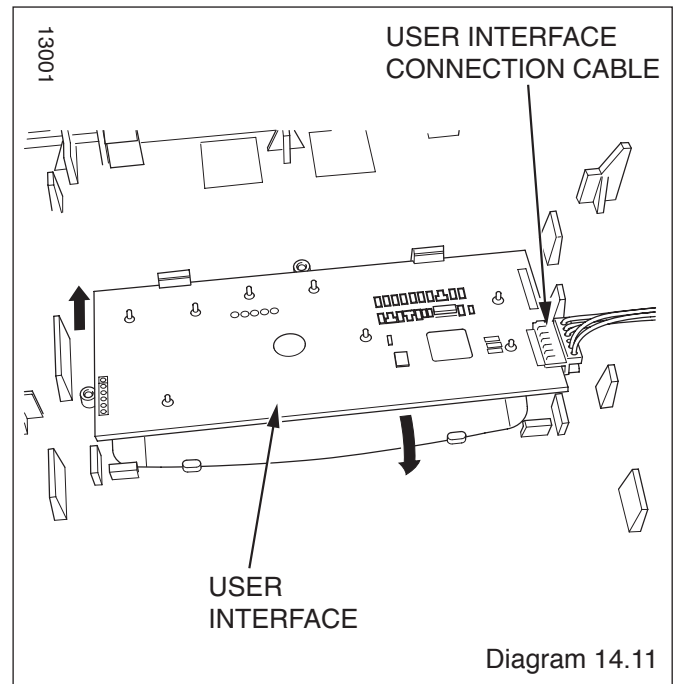
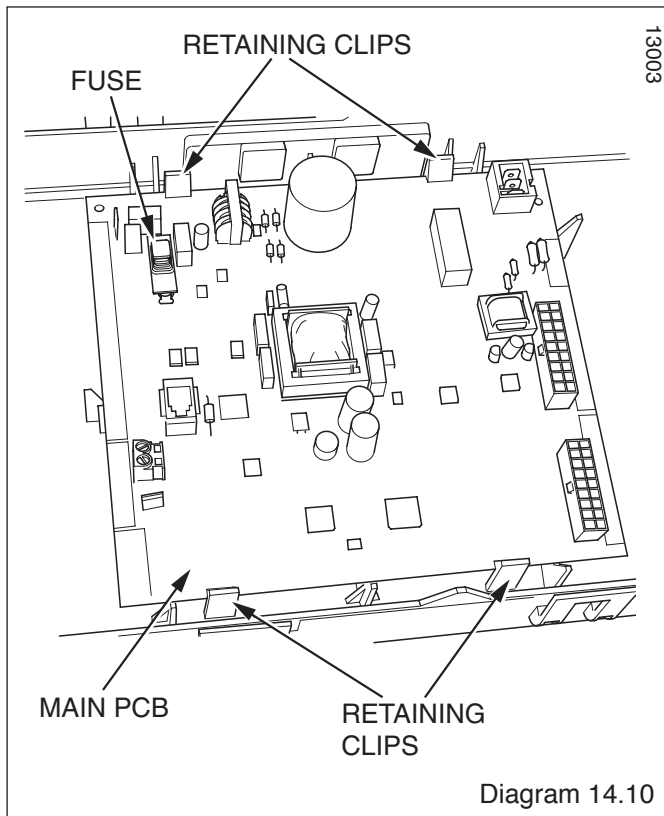

14.21 Access to User interface and Main PCB

For access, refer to section 14.1.

Hinge down the control box and unclip the rear cover to gain access.

Remove electrical connections from main PCB noting their positions for replacement.

Unclip main PCB and remove, see diagram 14.10.

Unclip user interface and remove.

For replacement, see diagram 14.11 and ensure that the user interface connection cable is refitted.

NOTE: When re-fitting any of the control boards make sure you support the control box to avoid straining hinges as you push down and clip back into place.

14.22 Control Box

For access, refer to section 14.1.

Hinge down the control box and unclip the rear cover to gain access.

Remove relevant electrical connections from main PCB and grommets from the control box.

IMPORTANT: Support the control box whilst undoing the hinges.

Remove the hinge securing screws accessed from beneath the boiler and remove the control box, see diagram 14.12.

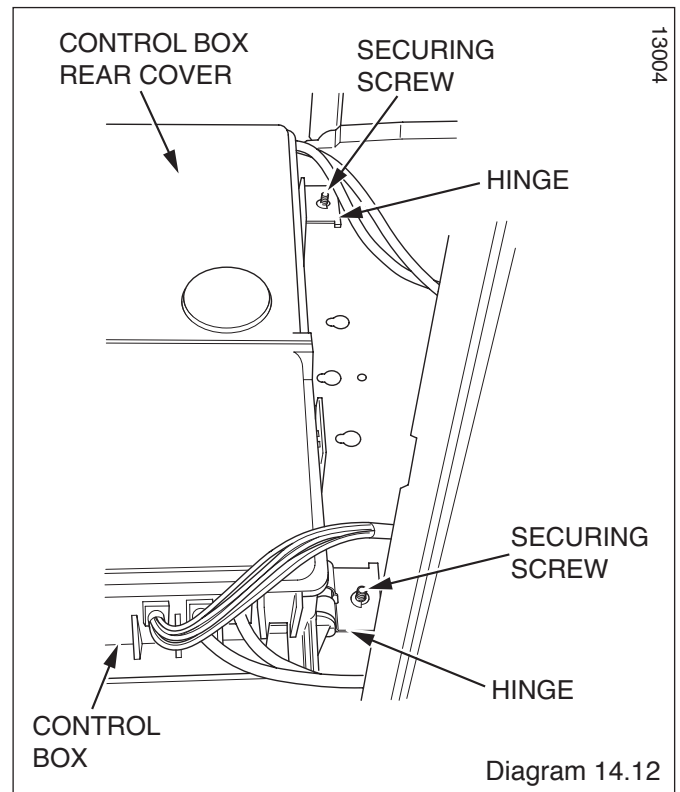

14.23 Fuse - Main PCB - Control Box

For access, refer to section 14.21.

The fuse is located at the top left hand corner of the main PCB, see diagram 14.10.

14.24 Installer Interface

Remove the Installer Interface securing screw accessed from beneath the boiler.

Carefully pull down the Installer Interface to remove, see diagrams 10.1 and 10.2.

15 Spare Parts

Key No.	Part No.	Description	GC No
1	0020020734	Fan	XXXXXX
2	0020020763	Igniter unit	XXXXXX
3	0020020781	Heating flow & return thermistor (2)	XXXXXX
4	0020014160	DHW thermistor	XXXXXX
5	0020020735	Gas valve	XXXXXX
6	0020020731	Spark electrode	XXXXXX
7	0020020728	Burner	XXXXXX
8	0020023826	User interface	XXXXXX
9	0020014180	Pump (head only)	XXXXXX
10	0020014190	Water pressure sensor	XXXXXX
11	0020023825	Main PCB	XXXXXX

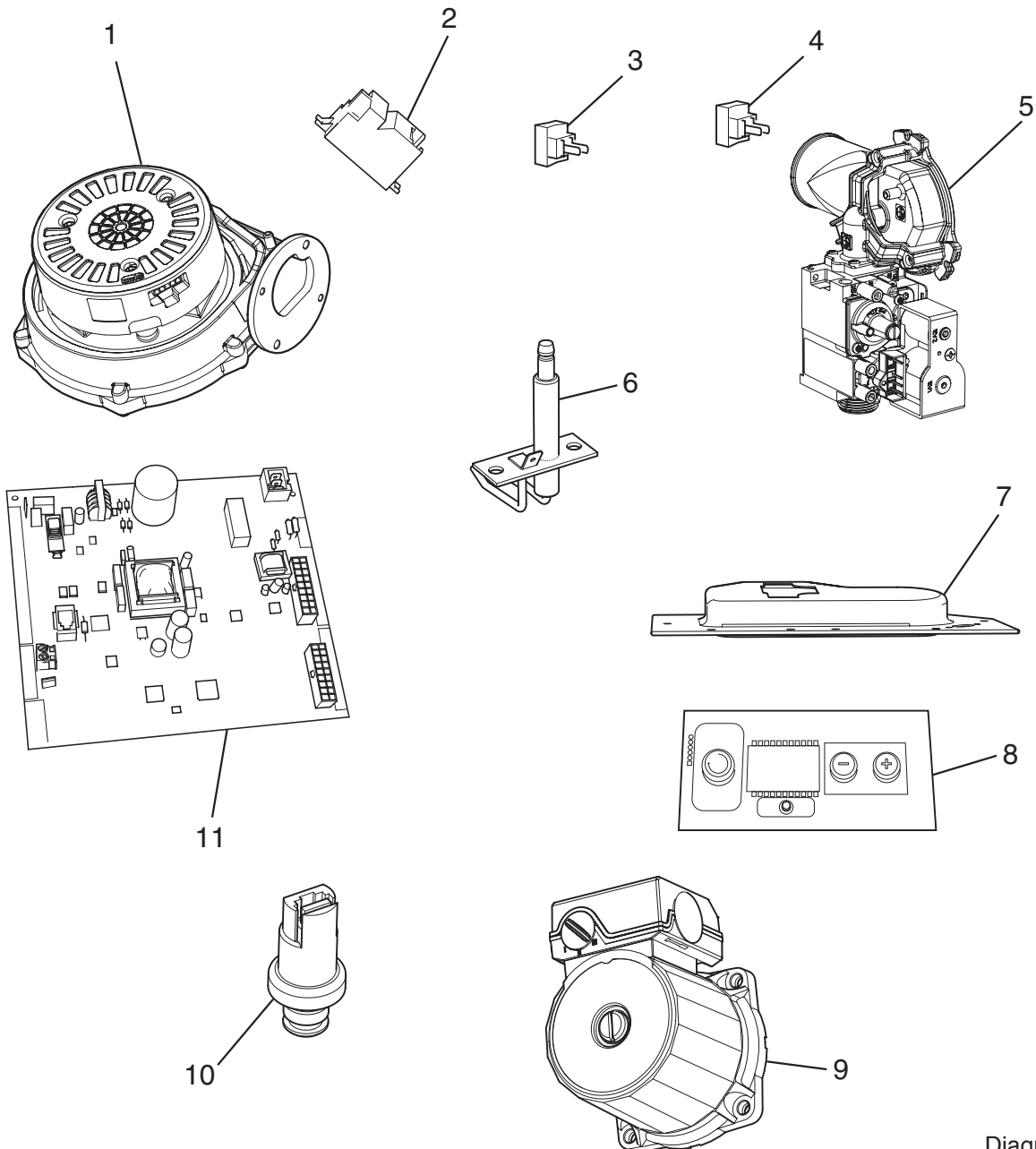

13049

Diagram 15.1

16 Manual Handling

IMPORTANT. With regards to the Manual Handling Operations, 1992 Regulations, the following lift operation exceeds the recommended weight for a one man lift.

General recommendations when handling

Clear the route before attempting the lift.

Ensure safe lifting techniques are used – keep back straight – bend using legs. Keep load as close to body as possible. Do not twist – reposition feet instead. If 2 persons performing lift, ensure co-ordinated movements during lift. Avoid upper body/top heavy bending - do not lean forward/sideways. Recommend wear suitable cut resistant gloves with good grip to protect against sharp edges and ensure good grip. Always use assistance if required.

Removal of carton from delivery van

Recommend 2 person lift or 1 person with use of sack truck. If 1 person is performing lift, straddle the load, tilt and place carton into position on truck. Recommend secure appliance onto truck with suitable straps. Ensure safe lifting techniques are used – keep back straight – bend using legs. Keep load as close to body as possible. If 2 persons performing lift, ensure co-ordinated movements during lift. Always use assistance if required.

Carriage of carton from point of delivery to point of installation – ground floor.

Recommend 2 person lift or 1 person with use of sack truck. If 1 person is performing lift, straddle the load, tilt and place carton into position on truck. Recommend secure appliance onto truck with suitable straps. Ensure safe lifting techniques are used – keep back straight – bend using legs. Keep load as close to body as possible. If 2 persons performing lift, ensure co-ordinated movements during lift. Clear the route before attempting the lift. If removing boiler from truck straddle the load and tilt forwards to facilitate secure grip. Ensure safe lifting techniques are used – keep back straight – bend using legs. Do not twist – reposition feet instead. Take care to avoid trip hazards, slippery or wet surfaces and when climbing steps and stairs. Always use assistance if required.

Carriage of carton from point of delivery to point of installation – first or higher floor, cellar.

Recommend 2-person lift or 1 person with use of sack truck. If 1 person is performing lift, straddle the load, tilt and place carton into position on truck. Recommend secure appliance onto truck with suitable straps. Ensure safe lifting techniques are used – keep back straight – bend using legs. Keep load as close to body as possible. If 2 persons performing lift, ensure co-ordinated movements during lift. Avoid upper body/top heavy bending - do not lean forward/sideways. Clear the route before attempting the lift. If removing boiler from truck straddle the load and tilt forwards to facilitate secure grip. Ensure safe lifting techniques are used – keep back straight – bend using legs. Do not twist – reposition feet instead. Take care to avoid trip hazards, slippery or wet surfaces and when climbing steps and stairs. Always use assistance if required.

Carriage of carton from point of delivery to point of installation – roofspace.

Recommend 2-person lift. Ensure co-ordinated movements during lift. Avoid upper body/top heavy bending - do not lean forward/sideways. Clear the route before attempting the lift. Take care to avoid trip hazards, slippery or wet surfaces and when climbing steps and stairs. When transferring appliance into roofspace, recommend 1 person to be in roofspace to receive the appliance and other person to be below to pass up and support appliance. Ensure safe lifting techniques are used – keep back straight – bend using legs. Keep load as close to body as possible. Always use assistance if required. It is assumed safe access, flooring and adequate lighting are provided in the roof space. It is recommended a risk assessment of the roof space area be carried out before moving the appliance into the area to take into account access, stability of flooring, lighting and other factors, and appropriate measures taken.

Unpacking of appliance from carton.

Recommend 2 persons unpack appliance from carton. Always keep working area clear. Recommend cut base end of carton and open carton flaps, then tilt boiler forwards from its side onto its base and remove carton by sliding up over the boiler. Ensure safe lifting techniques are used – keep back straight – bend using legs. Keep load as close

to body as possible. Always use assistance if required. Dispose of packaging in a responsible manner. Recommend wear suitable cut resistant gloves with good grip to protect against sharp edges and ensure good grip when handling appliance outside packaging.

Positioning of Appliance for Final Installation – no obstructions.

Recommend 2 persons lift appliance to position into place. Fit bracket securely onto wall before lifting appliance into position. Obtain firm grip on front and sides of appliance, lift upwards, ensure stable balance achieved and lift upwards to position in place on bracket. Ensure safe lifting techniques are used – keep back straight – bend using legs - when lifting load from floor level. Do not twist – reposition feet instead. Keep boiler as close as possible to body throughout lift to minimise strain on back. Ensure co-ordinated movements to ensure equal spread of weight of load. Always use assistance if required. Recommend wear suitable cut resistant gloves with good grip to protect against sharp edges and ensure good grip when handling appliance.

Positioning of Appliance for Final Installation – above worktop, foreseeable obstructions etc.

Recommend 2 persons lift appliance to position into place. Fit bracket securely onto wall before lifting appliance into position. Obtain firm grip on front and sides of appliance, lift upwards, onto worktop if practicable. Ensure stable balance achieved and lift upwards to position in place on bracket. If 2 persons positioning onto bracket obtain firm grip at front and sides/base of boiler. Ensure co-ordinated movements during 2 person lifts to ensure equal spread of weight of load. Ensure safe lifting techniques are used – keep back straight – bend using legs - when lifting load from floor level. Do not twist – reposition feet instead. Keep boiler as close as possible to body throughout lift to minimise strain on back. Avoid upper body/top heavy bending - do not lean forward/sideways. Always use assistance if required. Recommend wear suitable cut resistant gloves with good grip to protect against sharp edges and ensure good grip when handling appliance.

Positioning of Appliance for Final Installation – within compartment etc. restricting installation.

Recommend 2 persons lift appliance to position into place, space permitting. Fit bracket securely onto wall before lifting appliance into position. Obtain firm grip on front and sides of appliance, lift upwards, onto worktop if practicable. Ensure stable balance achieved and lift upwards to drop into place onto bracket. If 2 persons positioning onto bracket obtain firm grip at front and sides/base of boiler. Ensure co-ordinated movements during 2 person lifts to ensure equal spread of weight of load. If 1 person positioning onto bracket recommend obtain firm grip supporting base of boiler. Ensure safe lifting techniques are used – keep back straight – bend using legs - when lifting load from floor level. Do not twist – reposition feet instead. Keep boiler as close as possible to body throughout lift to minimise strain on back. Always use assistance if required. Recommend wear suitable cut resistant gloves with good grip to protect against sharp edges and ensure good grip when handling appliance.

Positioning of Appliance for Final Installation – in roof space restricting installation.

Recommend 2 persons lift appliance to position into place, space permitting. Fit bracket securely onto wall before lifting appliance into position. Obtain firm grip on front and sides of appliance, lift upwards, ensure stable balance achieved and lift upwards to drop into place onto bracket. If 2 persons positioning onto bracket obtain firm grip at front and sides/base of boiler. Ensure co-ordinated movements during 2 person lifts to ensure equal spread of weight of load. If 1 person positioning onto bracket recommend obtain firm grip supporting base of boiler. Ensure safe lifting techniques are used - keep back straight – bend using legs - when lifting load from floor level. Do not twist – reposition feet instead. Keep boiler as close as possible to body throughout lift to minimise strain on back. Always use assistance if required. Recommend wear suitable cut resistant gloves with good grip to protect against sharp edges and ensure good grip when handling appliance. It is recommended a risk assessment of the roof space area be carried out before moving the appliance into the area to take into account access, stability of flooring, lighting and other factors, and appropriate measures taken.



Because of our constant endeavour for improvement, details may vary slightly from those shown in these instructions.