

4 INSTALLING THE APPLIANCE

Before installing the appliance, check that the chosen location is suitable (section 3.2), and that the requirements for flue position (section 3.3), and minimum clearances (Fig. 1b) are satisfied.

4.1 UNPACKING THE APPLIANCE

The appliance and standard flue kit are supplied in a single box. In addition, various optional flue kits are available as described in section 2.6. If the appliance is to be installed without access to an external wall, a wall liner kit is also required.

4.2 PREPARING THE WALL

- Fix the paper template in the required position (ensuring that the necessary clearances are achieved) and mark the position of the fixing holes as shown in Fig. 16. Three holes are provided at each side of the wall bracket.
- Cut the hole in the wall for the air/flue duct. The diameter must not be less than 100mm and the hole must be horizontal. If the hole is not accessible from outside, its minimum diameter must be sufficient to allow insertion of the wall liner (130mm, 5¹/₄ in). The wall liner is available as an optional extra and must be sealed in position with mortar (or equivalent). It is recommended that the flue assembly falls slightly downwards away from the boiler.
- Drill two fixing holes using a 8mm drill and insert the wall plugs provided in the hardware pack. If any of the holes fail to provide a secure fixing, use one of the adjacent holes instead.
- Fix the bracket into position and secure to the wall using the two screws provided. Ensure it is level.

16

PAPER TEMPLATE

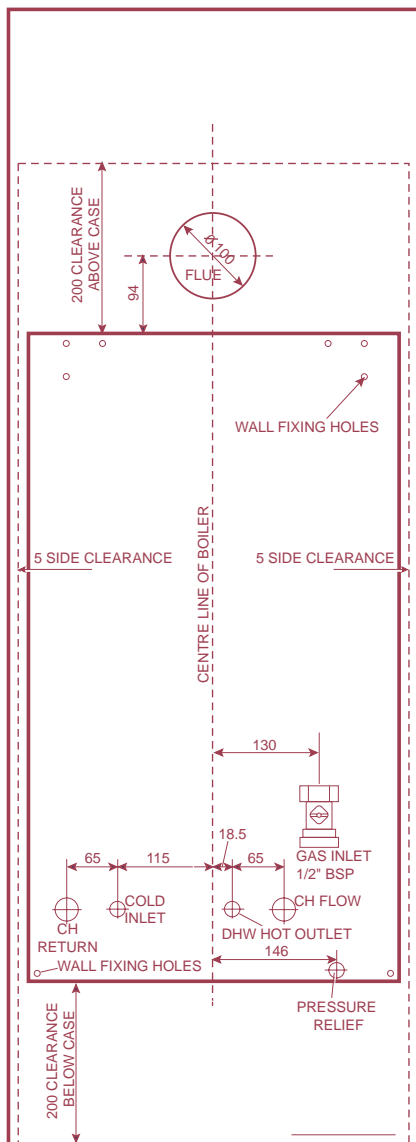

17

MOUNTING THE BOILER

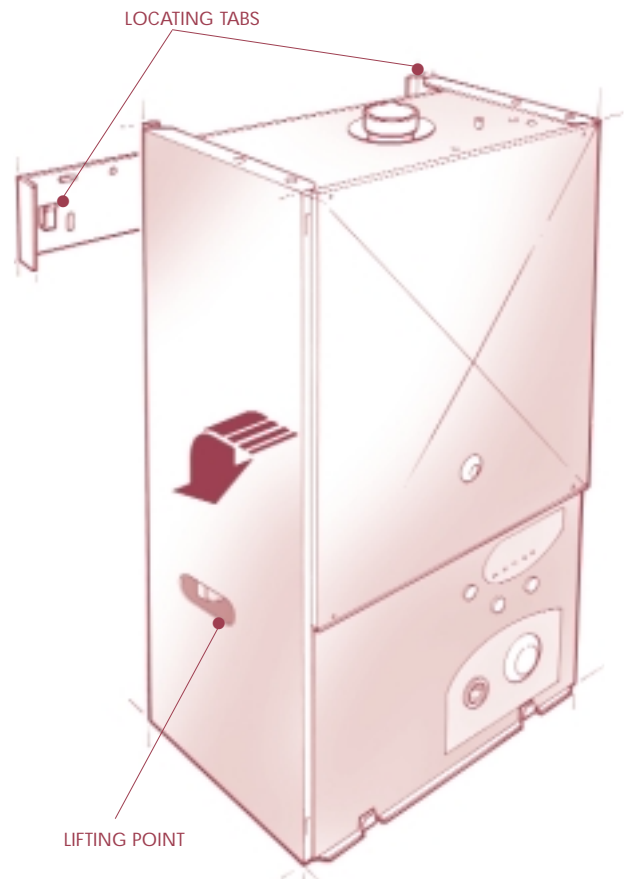

18

DETERMINING THE POSITION OF THE AIR/FLUE DUCT HOLE

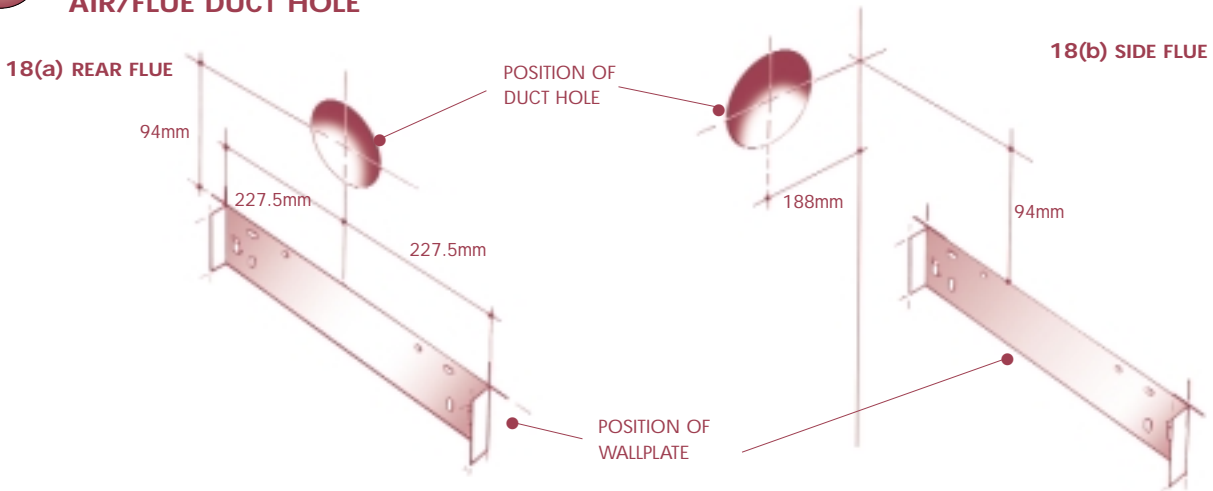

19

SERVICE CONNECTIONS (rear view)

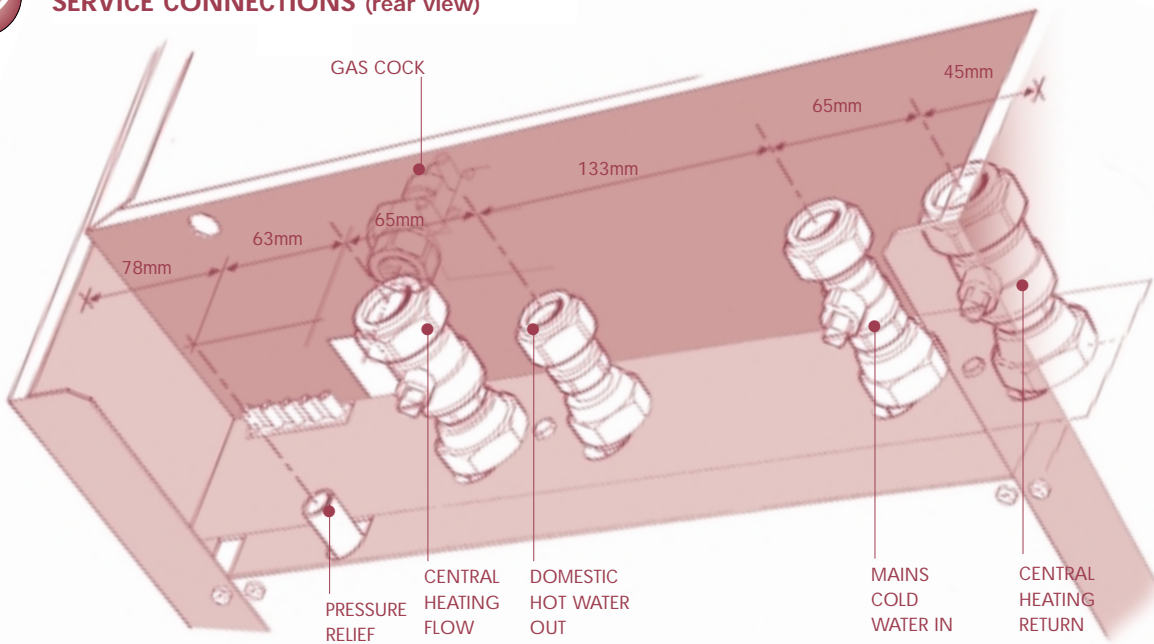

4.3 MOUNTING THE BOILER

- Lift the boiler into position using the lifting points shown in Fig. 17. Position the top of the boiler approximately 10mm above the top of the wall bracket and use the tabs on the wall bracket to locate the boiler in a horizontal direction, then carefully lower the boiler ensuring the two locating tabs are securely engaged (see Fig. 17).
- Locate and tighten the water and gas valves to the boiler. (Seals are pre-fitted).
- Connect the central heating system to the boiler flow and return using the connections shown in Fig. 19.
- Connect the mains water supply and outlet to the appropriate connections as shown in Fig. 19.

4.4 SERVICE CONNECTIONS

- Commission the central heating system as described in section 5.1, then proceed to section 4.5.

4.5 GAS CONNECTION

- Use a 15mm copper tube or bend to connect to the gas service cock to a 15mm compression fitting.

4.6 PRESSURE RELIEF VALVE PIPE CONNECTION

- Connect a suitable discharge pipe to the pressure relief valve tube. The pipe should be a minimum diameter of 15mm copper and should avoid any sharp corners or upward pipe runs where water may be retained. The discharge pipe must terminate in an area where any discharge will not cause a hazard but will be noticed.

4.7 AIR/FLUE DUCT INSTALLATION

If the wall thickness is less than 800mm (31 in) the air/flue duct may be fitted without access to the external wall providing that the optional wall liner is used. (This is necessary to seal any cavity and to allow the sealing ring to pass through from inside but still open and provide an adequate seal). The wall liner is a tube diameter 130mm with a wall thickness of 0.8mm.

4.7.1 PREPARING THE AIR/FLUE DUCTS

- Measure the required flue length as shown in Figure 20. Refer to section 2.6 to determine whether any extension kits are required. Installations using only the standard ducts or standard ducts with straight extensions are described in this section. Installation instructions for all other flue systems are described in the supplements at the rear of this booklet.
- Fit the external sealing ring to the terminal assembly and assemble the air/flue ducts as shown in Figure 21. The standard duct is always used at the entry / exit to the boiler, and the sliding (telescopic) terminal is always slid into the end of the standard or extension duct (where appropriate).
- Achieve the correct flue length using Figure 22 as a guide. Note that the flue length is measured to the inside of the external wall sealing ring. In most cases it will be possible to achieve the required flue length without cutting the ducts, however where necessary the plain ends of the extension ducts may be cut. **Never cut the swaged end**, and always ensure that the cut is square and free of burrs or debris. The minimum overlap of the telescopic section is 50mm (2 in).

20 MEASURING THE EXACT FLUE LENGTH

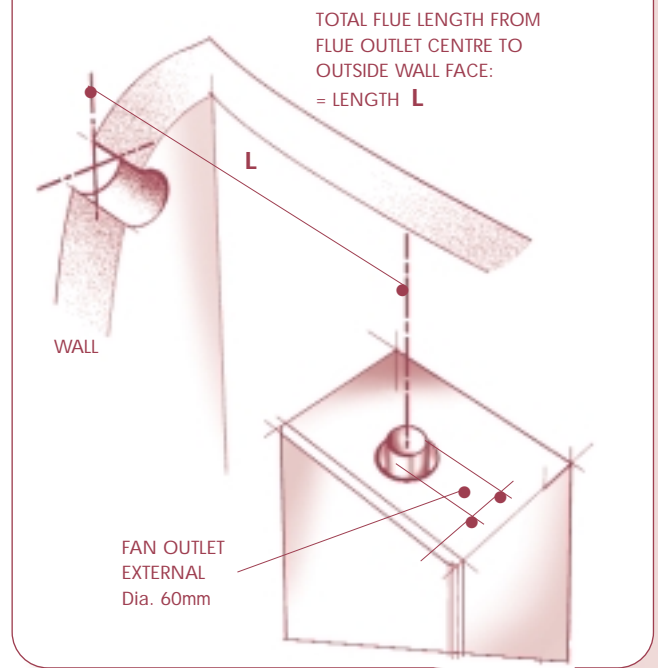

- Assemble the flue using Figure 23 as a guide. It is important that the steps are carried out in the order stated in Figure 23. When securing the ducts in position always drill two 3.3 mm diameter holes in each extension air duct joint and use the self tapping screws provided to secure each joint.

NOTE IT IS ESSENTIAL THAT THE TERMINAL IS FITTED THE CORRECT WAY UP See Fig 21 (i.e. rainshield at the top).

21 AIR/FLUE DUCT ASSEMBLY

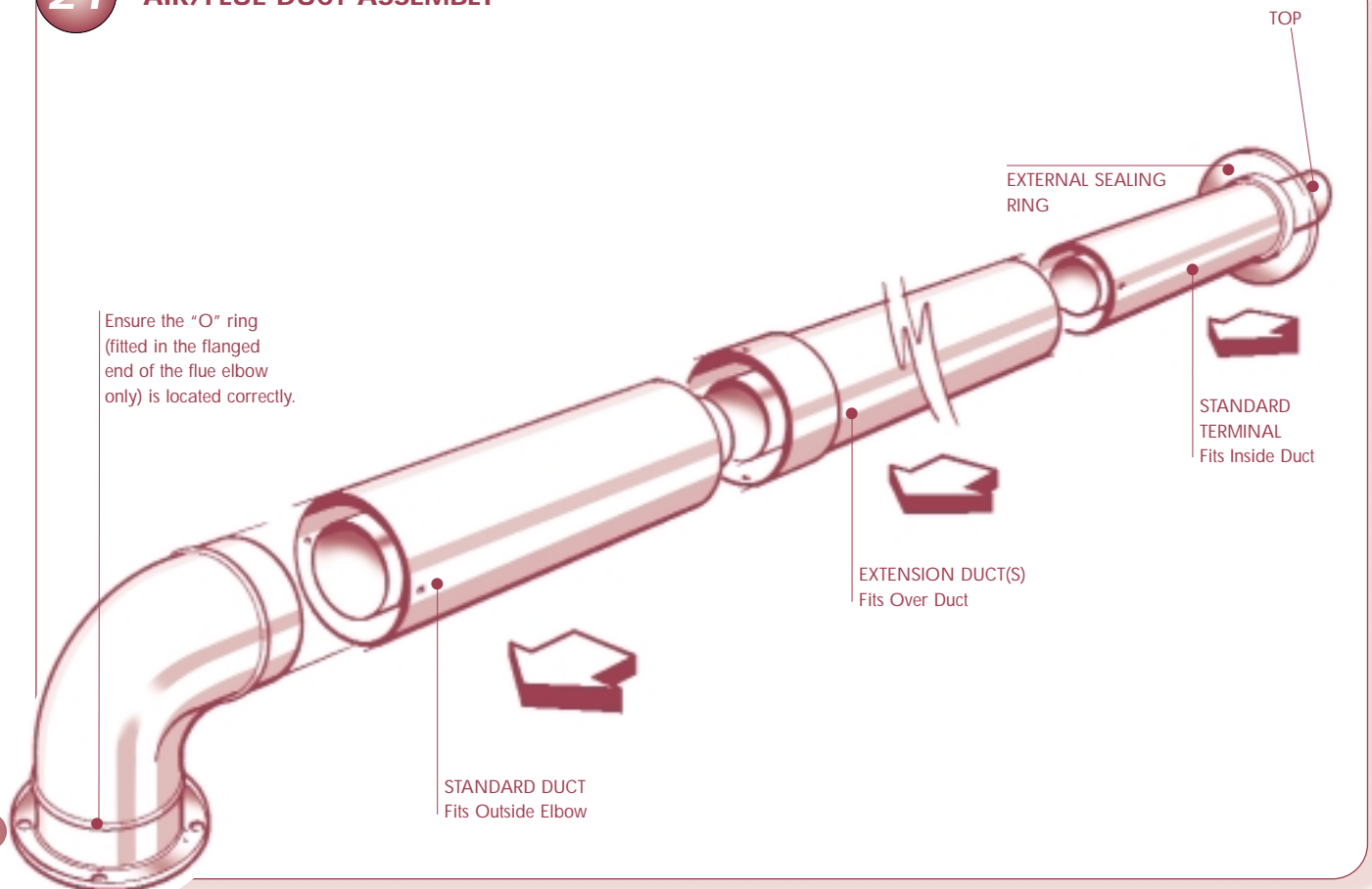

22

ACHIEVING THE CORRECT FLUE LENGTH

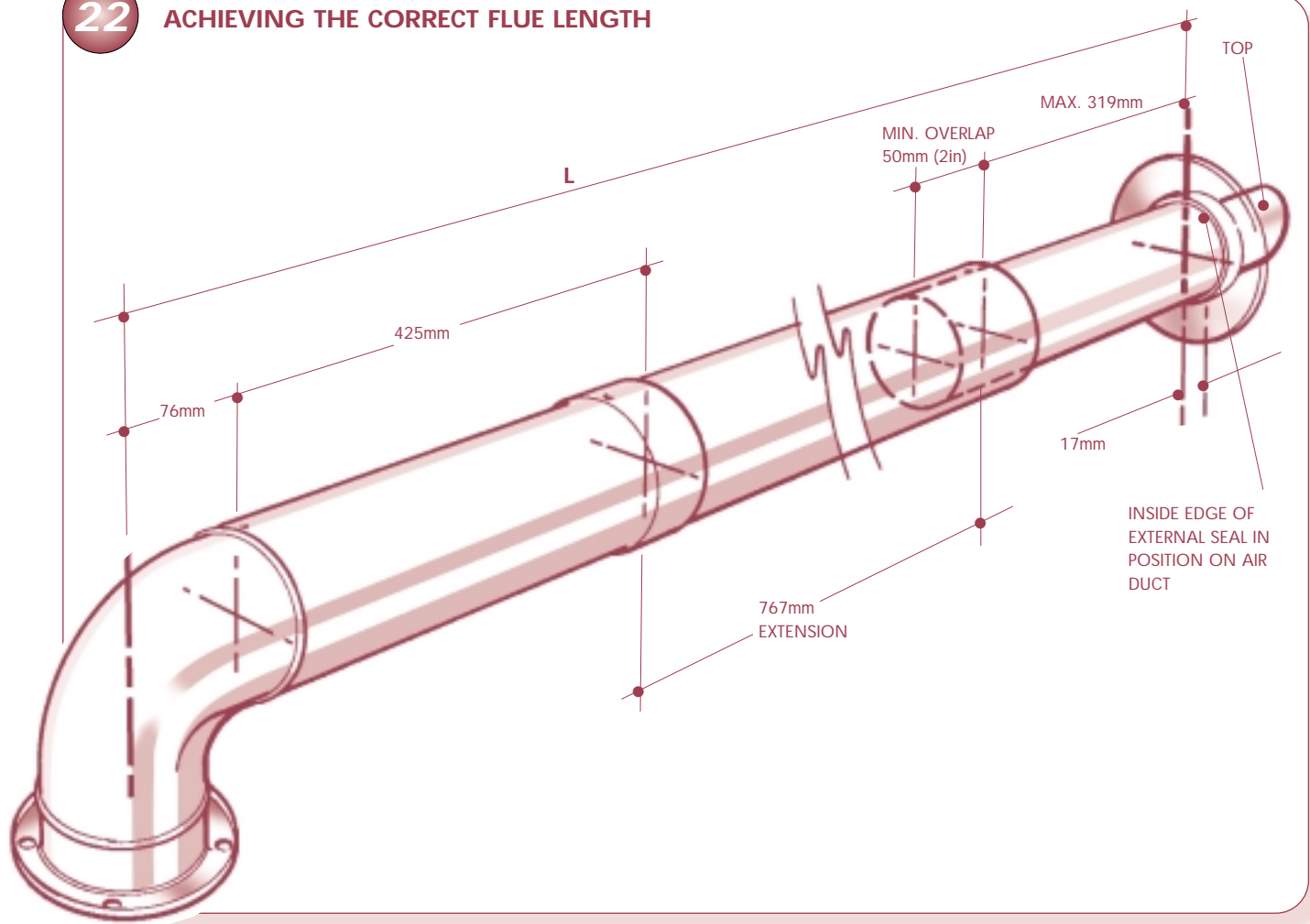

23

ASSEMBLING THE FLUE SYSTEM

1 SLIDE EXTERNAL SEALING RING UP TO FLUE TERMINAL

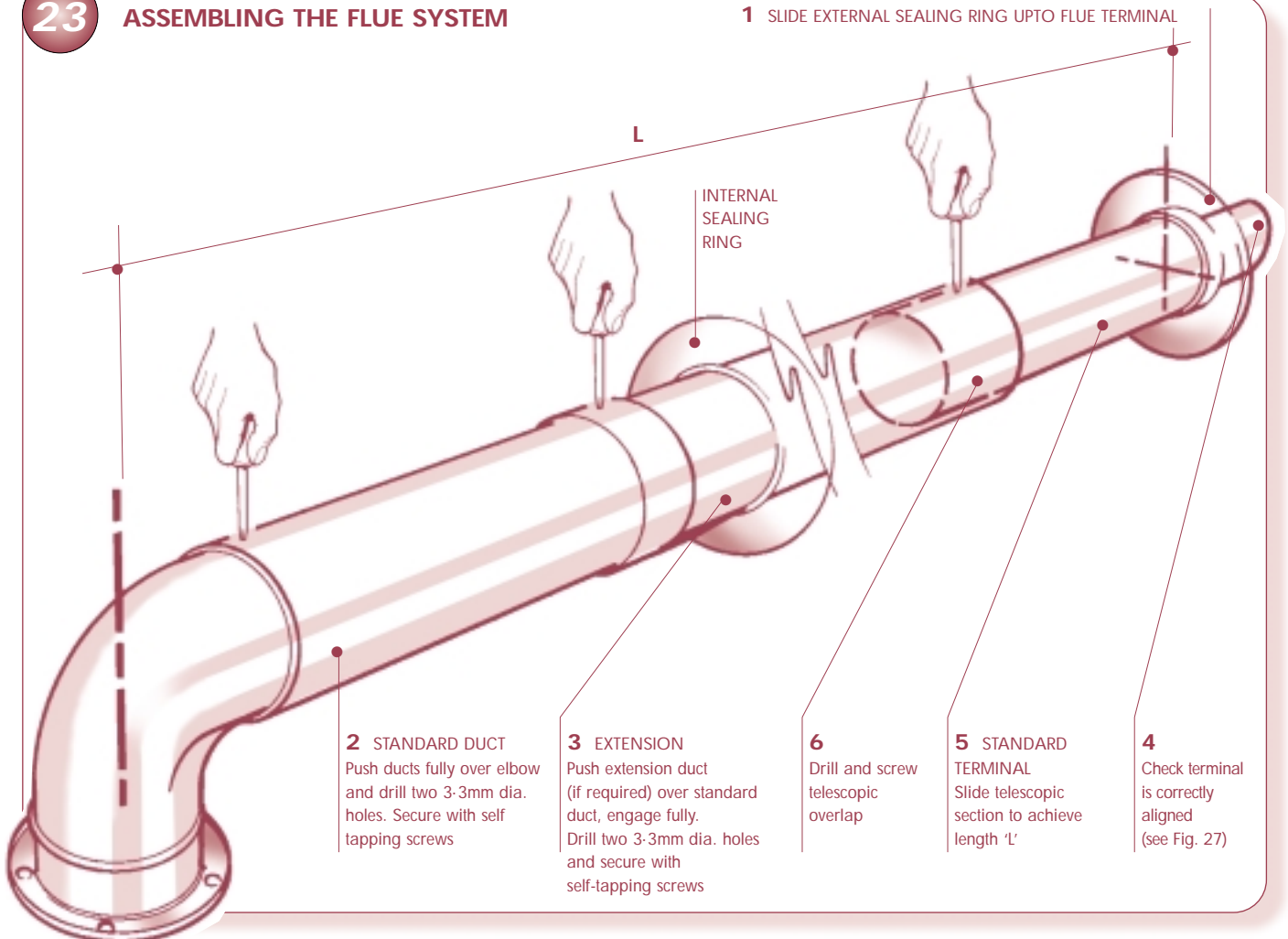

2 STANDARD DUCT
Push ducts fully over elbow and drill two 3-3mm dia. holes. Secure with self tapping screws

3 EXTENSION
Push extension duct (if required) over standard duct, engage fully. Drill two 3-3mm dia. holes and secure with self-tapping screws

6
Drill and screw telescopic overlap

5 STANDARD TERMINAL
Slide telescopic section to achieve length 'L'

4
Check terminal is correctly aligned (see Fig. 27)

4.7.2 FLUE RESTRICTOR

A flue restrictor is supplied with the appliance for use, only if no extensions or additional flue extension elbows are fitted.

If any extension ducts or additional elbows etc are to be used, proceed to section 4.7.3.

If only the standard flue components (i.e. those packed in the same carton as the appliance) are to be used fit the restrictor as follows:

- Note the position of the flue restrictor ring. This is fitted on top of the appliance and is secured by the air pressure switch bracket screws (Fig. 24). Loosen the air pressure switch screw by 1/2 turn only, to release the ring, and tighten the two screws.
- Fit the restrictor ring inside the flue elbow bottom as shown in figure 25 ensuring that it is the correct way round.

NOTES

- Failing to fit the restrictor when installing the appliance with a standard flue system will not provide optimum appliance performance.
- Fitting the restrictor on a flue system incorporating extensions or additional bends will adversely affect performance and

24 FLUE RESTRICTOR LOCATION

(Do not disturb if extension ducts are to be fitted)

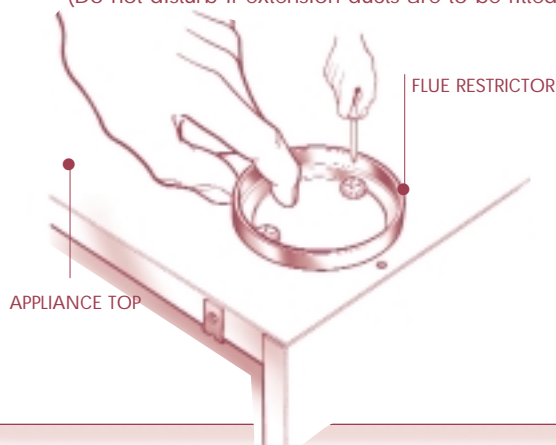

may constitute a safety hazard.

- Failing to comply with these instructions will invalidate the appliance Certification and therefore may contravene the appropriate EC legislation and local statutory requirements..

25 FITTING THE FLUE RESTRICTOR

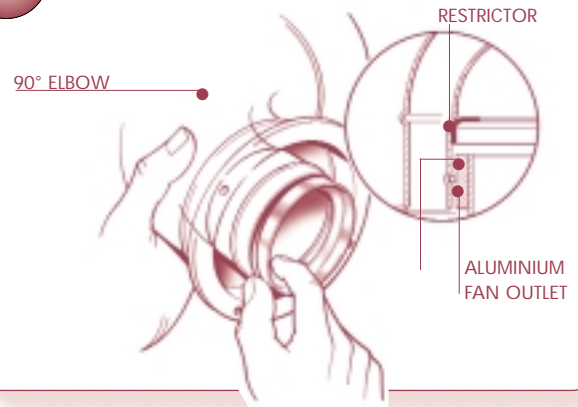

4.7.3 INSTALLING THE AIR/FLUE DUCT FROM INSIDE THE ROOM

Wall thickness up to 800 mm (31 in) only.

- Push the terminal through the wall liner taking care to ensure that the terminal is the correct way round and the external wall sealing ring does not become dislodged.
- Pull the flue system towards the boiler to seat the external sealing ring against the outside wall and secure the elbow to the boiler using the four screws provided.
- Finally use the internal sealing ring to make good the internal hole, and check that the terminal is correctly located on the outside wall (Where possible this should be visually checked from outside the building).

Figure 26 shows a view of the flue system correctly installed.

- Assemble as shown in Figure 26.

26 INSTALLING THE FLUE SYSTEM FROM INSIDE THE ROOM

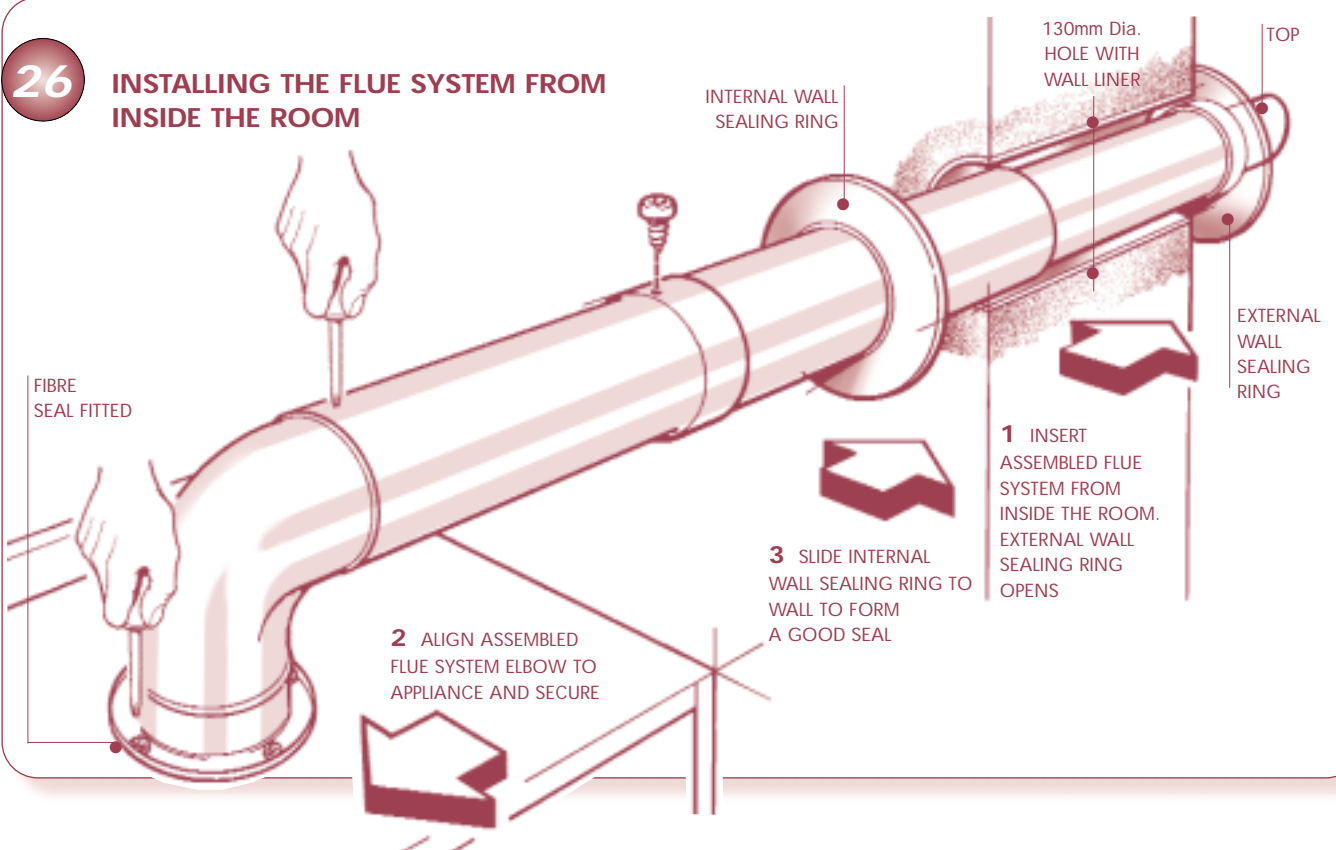

4.7.4 INSTALLING THE AIR/FLUE DUCT FROM OUTSIDE THE BUILDING

(Flue hole diameter 100mm - wall liner not necessary)

- Secure the flue elbow with seals and flue adaptor (where necessary) to the appliance using the 4 screws provided.
- Fit external wall sealing ring over flue and then from outside the building, push the flue system through the wall taking care to ensure that the terminal is the correct way around.

- Fit the internal wall sealing ring over the inside end of the flue, then fit the air duct to the elbow, drill and secure with the two screws.
- Pull the flue system towards the boiler to seat the external sealing ring against the outside wall and secure the air duct to the elbow using the two screws provided.
- Finally use the internal sealing ring to make good the internal hole. Check that the external wall sealing ring is correctly located, on the outside wall from outside the building.

Figure 27 shows a view of the flue system, correctly installed.

27 INSTALLING THE FLUE SYSTEM FROM OUTSIDE THE BUILDING

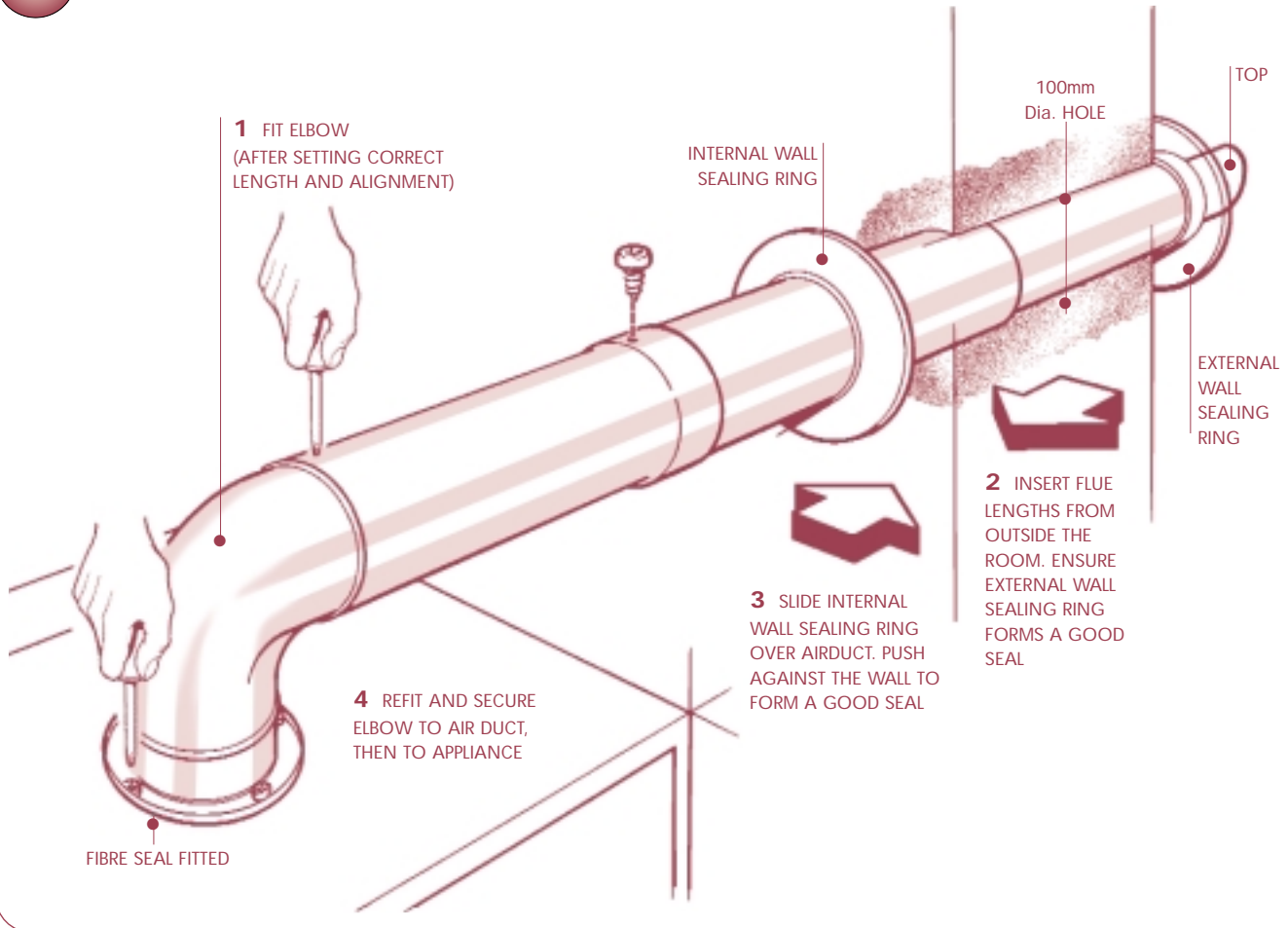

4.8 WIRING INSTRUCTIONS

Connect the electricity supply and external controls (using suitable mains cable) as follows:

Wire the cable(s) into the appropriate connections in the electrical plug provided (Figure 28). Live supply to L2, Neutral and Earth as indicated. Check that L1 and L3 are linked.

To provide correct cable retention, fit the piece of tubing supplied over the cable as it passes through the clamping arrangement. The cable will be held in position as the plug cover is fitted.

If a room thermostat is to be fitted remove the red link between L1 and L3 and connect the thermostat across these terminals. Any external controls fitted must be rated at 230V 50Hz and have volt-free contacts.

NOTE: Assuming that the appliance is to be commissioned immediately after installation it is not necessary to fit the casing panels at this stage.

28 ELECTRICAL CONNECTIONS (rear view)

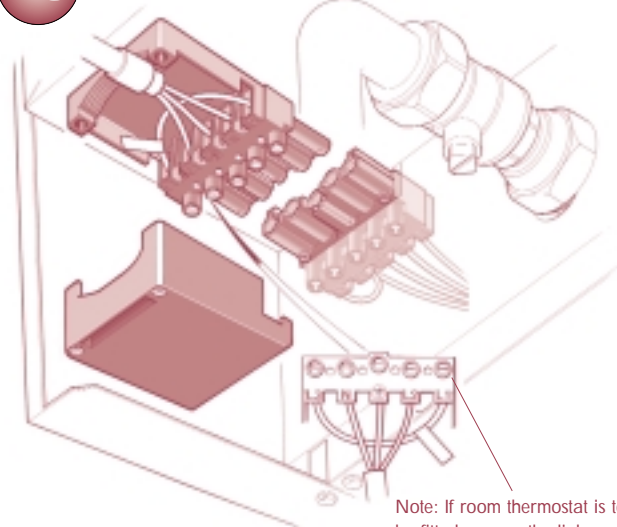

Note: If room thermostat is to be fitted remove the link and connect room thermostat across L1 and L3.