

high efficiency

heat-only boilers

icos HE

icos system HE

classic HE

mexico HE

imax W

***i* Ideal** BOILERS
The High Efficiency Pioneers



100
YEARS OF
Engineering
Excellence

Ideal Boilers and
Stelrad Radiators

1905 - 2005



contents

introduction	4
an appliance for any application	5
Product features	6
Building regulation compliance	7
icos & icos system HE	8-13
icos & icos system HE fluing options	14-21
icos & icos system HE extras and accessories	22-23
classic HE	24-27
mexico HE	28-31
classic & mexico HE fluing options	32-37
classic & mexico HE extras and accessories	38-39
imax W	40-41
supporting the installer	42
Combination & system storage boiler options	43

introduction

Welcome to the range of heat-only HE boilers from Ideal. Throughout you will find that exceptional reliability has been our overriding goal, and that the needs and expectations of the installer have been uppermost in our considerations.

World class manufacturing

Ideal is one of the most respected names in the heating industry and the only company in its field to have achieved 'World Class Manufacturer' accreditation in the prestigious IBM and London Business School UK manufacturing survey. For over 90 years we have been designing, refining and manufacturing appliances that are not only trusted by the trade, but also relied upon by homeowners the length and breadth of the country.

Our Hull-based factory is part of only 2% of all manufacturing sites in the UK that have been independently judged as meeting the criteria for World Class Manufacturing status, while our superior manufacturing facilities mean that we can achieve 'right first time' quality. In accordance with the company's World Class status, we have adopted a programme of continuous improvement which ensures that we constantly measure and monitor our performance to drive improvement through innovation.

Dedicated to excellence

Everyone at Ideal is committed to delivering incomparable quality. Which is why these products have been created to lead the way in innovative engineering, inspired design and, above all else, exceptional standards of reliability.

Engineered for peace of mind

The components which have been used throughout the appliances are not only manufactured to extremely high technical specifications, they are also common across the range. As a result, the HE range of boilers are dependable, simple to understand and require minimal maintenance and servicing.

To ensure this dependability, each of our boilers is also subjected to an extraordinarily stringent regime of product assessment. This includes rigorous application testing, as well as extensive laboratory and field trials.

What's more, the versatile design, which includes no compartment ventilation and twin-pipe fluing, makes siting extremely flexible - meaning minimum hassle at no extra cost for the installer.

Glossary of terms

- FF = fan-flued boiler
- TRV = thermostatic radiator valve
- CH = central heating
- DHW = domestic hot water
- PCB = printed circuit board

an appliance for any application

The boilers featured in this brochure cover heat-only and system applications.

icos high-efficiency boiler

Thanks to its flexibility of siting, ease of installation and advanced reliability, Ideal's icos HE high-efficiency boiler is a further improvement on previous models. It can be fitted in conjunction with any fully pumped system and is available in four models, icos HE 12, icos HE 15, icos HE 18 and icos HE 24.

SEDBUK rating



icos system high-efficiency boiler

The Ideal icos system HE high-efficiency boiler shares the same benefits as its heat-only counterpart, but has all the necessary components incorporated into the product to enable easy installation to a fully pumped sealed system.

SEDBUK rating



classic HE cast iron high-efficiency boiler

The classic HE boiler is suitable for installation on a system that includes a separate hot water cylinder and loft water tank. The classic HE is a highly reliable fan-assisted cast iron wall hung boiler that will offer years of trouble-free service. Its ease of installation, flexible fluing and siting options and use of proven technology all ensure that the classic HE is amongst the most installer-friendly boilers available.

The Ideal classic HE high-efficiency boiler is a straightforward design based on the proven classic SE, offering easy installation and servicing. A range of 4 models, from 9kW to 18kW, provides a choice for any installation.

SEDBUK rating



mexico HE floor standing high-efficiency boiler

The mexico HE boiler is suitable for installation on a fully pumped system that includes a separate hot water cylinder and loft water tank. The mexico HE is a highly reliable fan-assisted aluminium floor standing boiler that will offer years of trouble-free service. Its ease of installation, flexible fluing and siting options and use of common parts all ensure that the mexico HE is amongst the most installer-friendly boilers available.

The Ideal mexico HE high-efficiency boiler is a straightforward design, offering easy installation and servicing. A range of 5 models, with outputs from 8.8kW to 37kW, provides a choice for any installation.

SEDBUK rating



imax W high-efficiency boiler

Designed for the larger installation requiring greater heat outputs than the icos HE range. It can be fitted in fully pumped systems and has a wide range of flue options.

SEDBUK rating

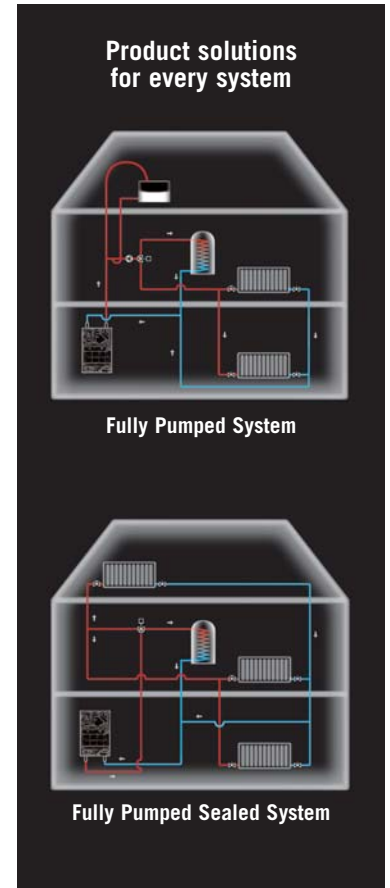

product features

Each of Ideal's HE boilers contains only those parts that are necessary to deliver dependability and performance, or that make the product easier to fit, operate or install. As a result, they all offer exceptional levels of reliability and are easily maintained and serviced.

Common components

Many Ideal HE appliances share a wide number of common parts – making them easier to install, service, and maintain. These items include components such as the gas valve, burner, venturi, fan, fluing system and controls.

Easy siting

All Ideal HE appliances are available with a wide range of flue options. These make siting the boiler in the property easier as long flues can be used. It also makes positioning the flue terminal easier.

Simple to fit and service

Because they have so much in common, fewer spares are required to maintain the range of boilers.

Most products are 'self-adjusting'. This allows the installer to fit the products without the need to make any alterations. The boilers, being fully modulating, (classic HE excepted) adjust themselves to the required output to meet the heating load.

Unprecedented reliability

We have introduced new test procedures which are comprised of a demanding series of application tests to ensure that the boiler is fault-free.

We have never been tougher on ourselves or our products, and you will find that it shows in the new standards of reliability which these products have attained.

PRODUCT FEATURES

	icos HE heat-only	icos HE system	classic HE heat-only	mexico HE heat-only	imax W
Remotely mountable user controls (optional kit required)	✓	✓	n/a	✓	n/a
Alpha-numeric diagnostic display	✓	✓	n/a	✓	✓
Kitchen cupboard fit*	✓	✓	✓	✓	n/a
No compartment ventilation required	✓	✓	n/a	✓	n/a
Syphon kit available	✓	✓	standard	✓	n/a
Boiler stand-off kit	✓	✓	✓	✓	n/a

* **Note:** When stand-off brackets are fitted, standard kitchen cupboard fit does not apply.
classic HE - see particular requirements.

Note: For icos heat-only and system boilers, where a mid-position diverter valve is used, a bypass is not necessary as one circuit will always be open. Where the system is designed so that both circuits can be closed simultaneously, then a bypass must be fitted, comprising at least 3 metres of 22mm copper tube, including a lockshield or automatic valve set to achieve a maximum of 11°CΔT.

building regulation compliance

To comply with Part L of the Building Regulations 2005, domestic boilers are required to meet minimum SEDBUK ratings of 86%. Building Standards (Scotland) Part J require 78% minimum.

SEDBUK - Seasonal Efficiency of Domestic Boilers in the UK

The SEDBUK efficiency of a domestic boiler is an approved method of representing the energy efficiency of a boiler under assumed typical operating conditions.

A boiler's efficiency is calculated using the SEDBUK rating (Seasonal Efficiency of Domestic Boilers in the UK). This rating defines the average annual efficiency of a domestic boiler achieved in typical domestic conditions, making reasonable assumptions about pattern of usage, climate, control and other influences. SEDBUK efficiencies are banded A-G (with A being the highest). The Ideal products icos HE, icos system HE, mexico HE and imax W are SEDBUK A rating approved with energy ratings over 90%. They are all Energy Efficiency List recommended. The classic HE is SEDBUK B rated with an efficiency greater than 86%.

These high-efficiency boiler ranges exceed current Building Regulations 2002 and will meet all the requirements of the proposed 2005 Regulations.

Band	SEDBUK range
A	Above 90%
B	86% – 90%
C	82% – 86%
D	78% – 82%
E	74% – 78%
F	70% – 74%
G	Below 70%

Caradon Ideal Ltd hereby declare that the boilers listed below meet the essential requirements for heating plant as described in: Building Regulations - Part L1 2005. Building Standards (Scotland) Regulations - Part 'J'.

DETAILS OF COMPLIANCE

Boiler	Range	Certificate No.	Notified body	Reference
icos HE	12 - 24kW	E0818	Gastec	0063
icos system HE	24kW	E0818	Gastec	0063
classic HE	9 - 18kW	tba	Advantica	0087
mexico HE	15 - 37kW	tba	Gastec	0063
imax W	45 - 80kW	BN32181	Gastec	0063



ideal

icos

icos HE and icos system HE

The Ideal high-efficiency heat-only and system boilers

These high-efficiency boilers from Ideal combine a modern, stylish exterior with simple yet highly reliable engineering. This has resulted in appliances that are easily installed and that require minimal servicing and maintenance, while to the homeowner it represents an advanced, dependable product which looks at home in any environment and offers years of trouble-free service, as well as a reduction in gas bills.

Application and usage

Flexibility of siting, ease of installation and advanced reliability all mean that Ideal's high-efficiency heat-only and system boilers offer further improvements on previous models. Thanks to the 80mm diameter twin-pipe fluing feature, which offers a maximum combined fluing length of up to 46 metres that can be run either horizontally or vertically, the icos HE and icos system HE can now be installed much further away from the outside wall. This means the boilers can be fitted safely and unobtrusively in almost any situation. Condensate drainage can be overcome using the optional Ideal condensate pump kit.

The icos HE and icos system HE in operation

Both products are automatically controlled, fan-flued high-efficiency boilers. They modulate their heat output to suit the demands of the heating load, and both incorporate a variable thermostat for CH temperature control, adjustable from 30°C to 82°C.

The use of a pre-mix burner allows control of gas input to the appliance to be directly linked to fan speed. So, as the fan reduces speed to match heating load, the gas valve maintains the correct proportional flow ensuring a high boiler efficiency throughout its output range.

1 year product warranty

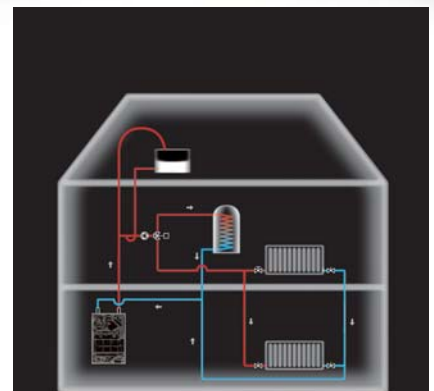

Fully Pumped System

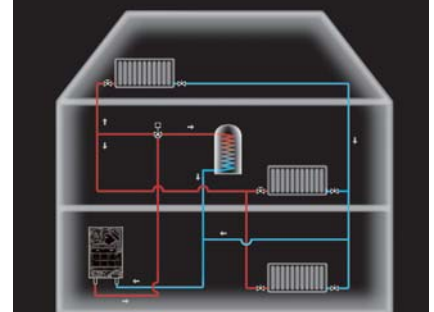

Fully Pumped Sealed System



icos HE

icos HE- technical data

Compact dimensions of height 582mm, width 397mm and depth 290mm and **no compartment ventilation required**, ensure kitchen cupboard fit and provide siting flexibility.

Fully modulating product with outputs up to 24kW (80,000Btu/h) ensuring maximum efficiency, suitable for a wide range of heating requirements.

'Self-adjusting' feature reduces time and cost of installation, and makes installation much simpler.

Built-in condensate 'S' trap with simple connection makes installation easier.

Hinged control PCB box with easy access to connections for simplified servicing and installation.

Easy-to-wire mains electrical connection makes installation easier.

Low lift weight of 32kg offers easy installation.

'Downward firing' pre-mix burner for greater reliability, ensuring lower Nitrogen Oxide emissions (environmentally friendly).

Cast-aluminium heat exchanger ensures tough, dependable construction and performance.

Alpha-numeric diagnostic readout gives essential, easy-to-read operation indicators and shows boiler status together with fault codes, in the unlikely event of a problem.

Optional remotely mountable user controls improve siting flexibility. Includes wall mounting plate, blank housing (including PCB, fixing screws and instructions).

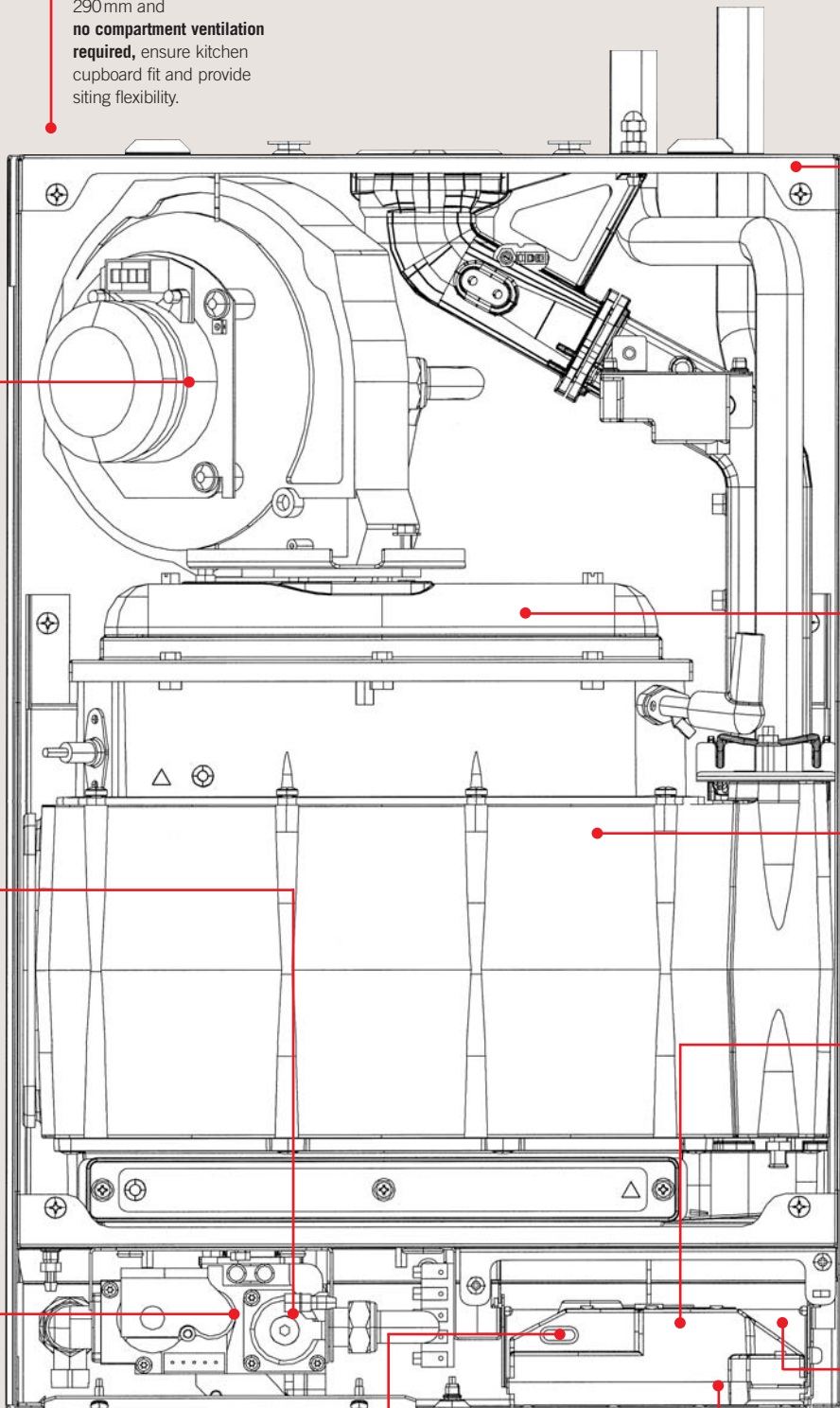

PERFORMANCE DATA

Model		icos HE 12	icos HE 15	icos HE 18	icos HE 24
Output	kW	9.3 - 12	8.8 - 14.6	8.8 - 18.2	8.8 - 23.4
	Btu/h	31,800 - 41,000	30,000 - 49,800	30,000 - 62,100	30,000 - 80,000
SEDBUK rating		A	A	A	A
NOX Class		5	5	5	5

INSTALLATION DATA

Gas supply connection	inches	Rc 1/2 (1/2" BSP female)
CH flow connection	mm	22 compression*
CH return connection	mm	22 compression*
Condensate drain	mm	21.5
Electrical supply	V/Hz	230 / 50
Power consumption	W	38
Fuse rating	A	3
Water content	litres	1.7
Maximum lift weight	kg	32
Total packed weight	kg	35
Flue terminal diameter	mm	100
S trap depth	mm	52

*For outputs exceeding 18kW (60,000 Btu/h), 28mm primary pipework will be required.

CLEARANCE DATA

The following clearances are required for installation, servicing and replacement of parts.

Front of boiler	Sides of boiler	Top of boiler	Bottom of boiler
450mm	5mm	165mm**	100mm†

† Minimum clearance required at bottom of boiler for servicing is 100mm, additional clearance will be required for installation, depending upon site conditions.

**More clearance required when fitting fluing to the side.

PIPEWORK CONNECTIONS AND PRODUCT DIMENSIONS

Flue plumbing is a by-product of efficiency. Please be aware of terminal positions to avoid complaints (see pages 14-21, fluing options).

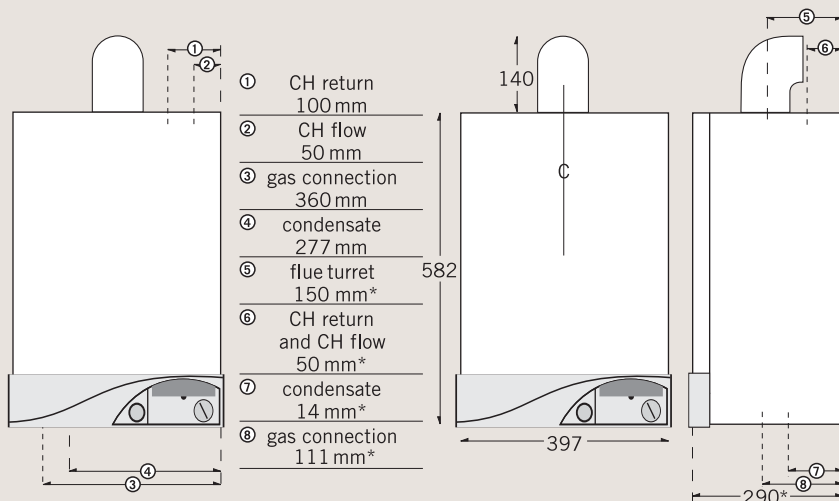

*Add 32mm with stand off brackets fitted

For full technical details please refer to the Installation and Servicing Instructions provided with the product.

The Ideal high-efficiency boiler

Installation tips

Ideal recommend that a minimum heating load of 3,000 Btu/h be controlled using a room thermostat, leaving all other rooms capable of being controlled by TRVs.

The boiler has a cast-aluminium alloy heat exchanger, therefore suitable water treatment should be applied to the system.

These boilers require a permanent live electrical supply.

Siting options



Loft



Utility Room

Optional remotely mountable user controls, compact dimensions and a highly flexible fluing system allow the icos HE to be easily sited.

SEDBUK rating



This product has an energy rating of A on a scale of A-G. For more information see www.sedbuk.com

Note: This product is not suitable for external installation. The wall on which the boiler is being mounted must be able to support its total weight. The wall will not require special protection, but if the unit is being fitted in a timber-frame building the guidelines set out in BS 5440: Part 1:1990 should be observed.

icos system HE - technical data

Compact dimensions of height 687mm, width 397mm and depth 290mm and **no compartment ventilation required**, ensure kitchen cupboard fit and provide siting flexibility.

Fully modulating product with outputs from 8.8 to 24kW (30,000 to 80,000 Btu/h) suitable for a wider range of applications, and ensures maximum efficiency throughout the boiler's modulation range.

'Downward firing' pre-mix burner for greater reliability, ensuring lower Nitrogen Oxide emissions (environmentally friendly).

Built-in condensate 'S' trap with simple connection makes installation even easier.

Hinged control PCB box with easy access to connections for simplified servicing and installation.

Optional remotely mountable user controls improve siting flexibility. Includes wall mounting plate, blank housing (including PCB, fixing screws and instructions).

Low lift weight of 40 kg offers easy installation.

Cast-aluminium heat exchanger ensures tough, dependable construction and performance.

'Self-adjusting' feature reduces time and cost of installation, and makes installation much simpler.

A single manifold to house the pump and pressure relief valve means there are fewer connections between boiler components, improving reliability and reducing the overall product weight.

Alpha-numeric diagnostic readout gives essential, easy-to-read operation indicators and shows boiler status together with fault codes, in the unlikely event of a problem.

Easy-to-wire mains electrical connection makes installation easier.

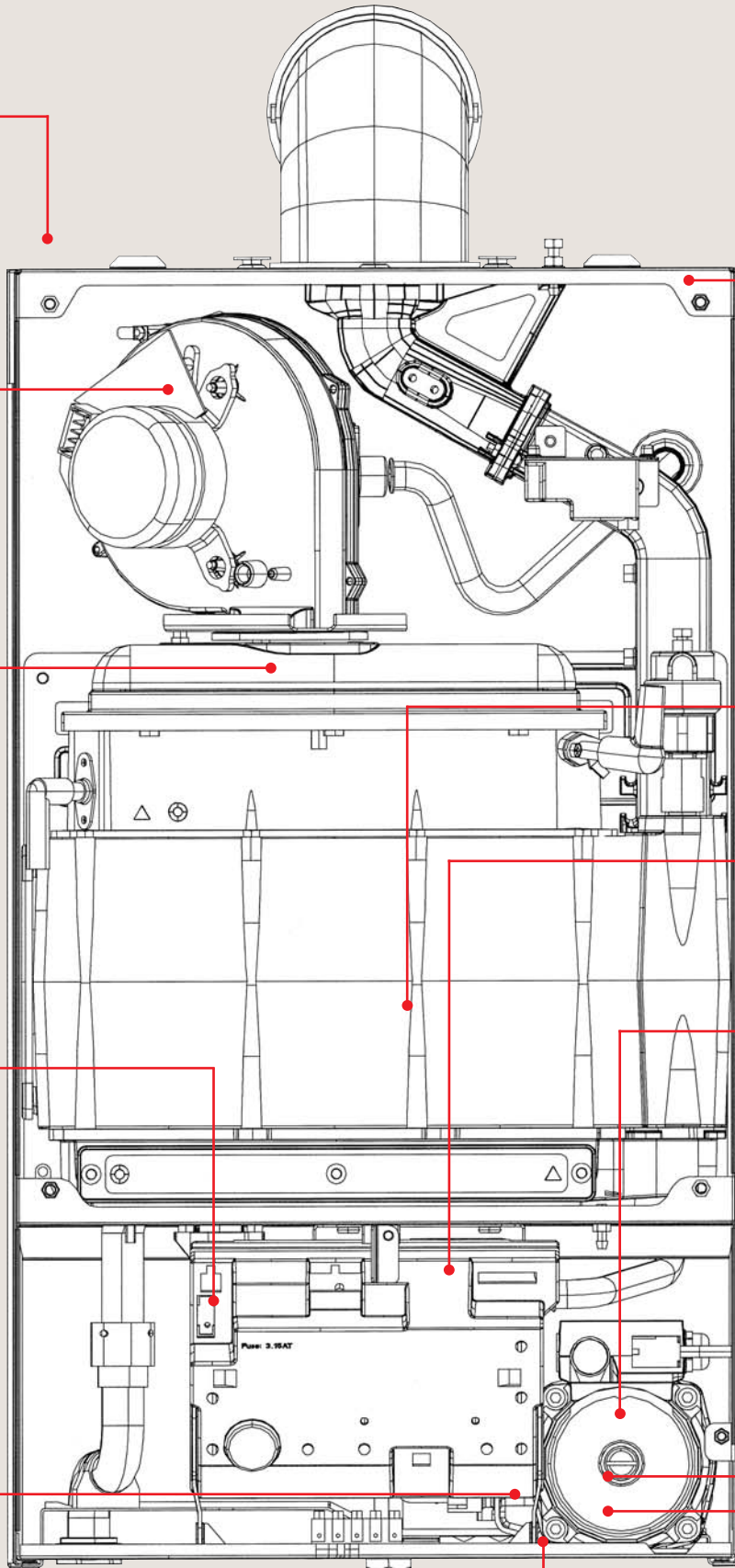

PERFORMANCE DATA

Model	icos system HE 24	
Output	kW	8.8 - 23.4
	Btu/h	30,000 - 80,000
SEDBUK rating	A	
NOX Class	5	

INSTALLATION DATA

Gas supply connection	inches	Rc 1/2 (1/2" BSP female)
CH flow connection	mm	22 compression*
CH return connection	mm	22 compression*
Expansion vessel volume	litres	8
Pressure relief valve	inches	Rc 1/2 (1/2" BSP female)
Condensate drain	mm	21.5
Power consumption	w	148
Electrical supply	V/Hz	230/50
Fuse rating	A	3
Water content	litres	2
Maximum lift weight	kg	40
Total packed weight	kg	47
Flue terminal diameter	mm	100
S trap depth	mm	52

*For outputs exceeding 18kW (60,000Btu/h), 28mm primary pipework will be required.

CLEARANCE DATA

The following clearances are required for installation, servicing and replacement of parts.

Front of boiler	Sides of boiler	Top of boiler	Bottom of boiler
450mm	5mm	165mm**	100mm†

† Minimum clearance required at bottom of boiler for servicing is 100mm, additional clearance will be required for installation, depending upon site conditions.

**More clearance required when fitting fluing to the side.

PIPEWORK CONNECTIONS AND PRODUCT DIMENSIONS

Flue plumbing is a by-product of efficiency. Please be aware of terminal positions to avoid complaints (see pages 14-21, fluing options).

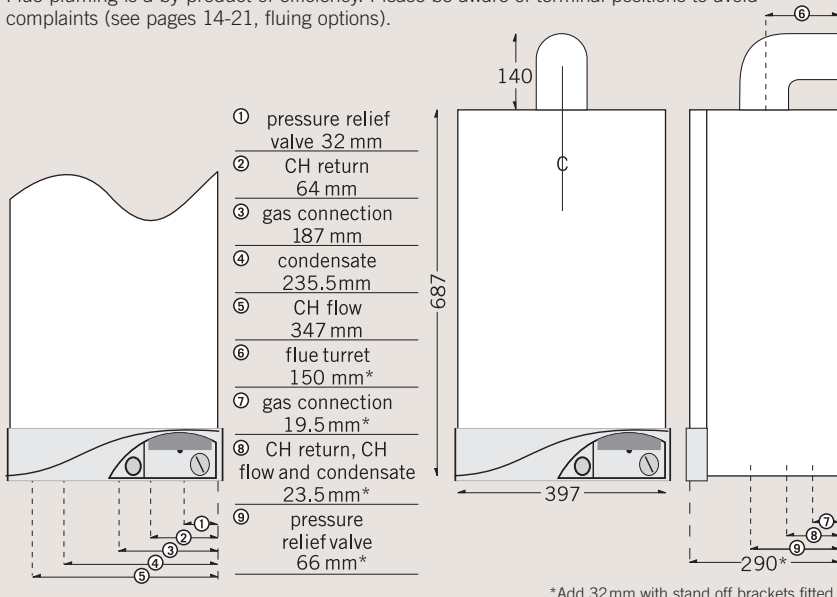

For full technical details please refer to the Installation and Servicing Instructions provided with the product.

The Ideal high-efficiency system boiler

Installation tips

Ideal recommend that a minimum heating load of 3,000 Btu/h be controlled using a room thermostat, leaving all other rooms capable of being controlled by TRVs.

The boiler has a cast-aluminium alloy heat exchanger, therefore suitable water treatment should be applied to the system.

These boilers require a permanent live electrical supply.

Siting options



Loft



Utility Room

Optional remotely mountable user controls, compact dimensions and a highly flexible fluing system allow the icos system HE to be easily sited.

SEDBUK rating



This product has an energy rating of A on a scale of A-G. For more information see www.sedbuk.com

Note: This product is not suitable for external installation. The wall on which the boiler is being mounted must be able to support its total weight. The wall will not require special protection, but if the unit is being fitted in a timber-frame building the guidelines set out in BS 5440: Part 1:1990 should be observed.

fluing options

The heat-only HE range from Ideal boilers benefits from a wide variety of fluing options, making it possible for the installer to fit each unit safely and unobtrusively in almost any situation. The following information sets out the alternatives that are available and demonstrates the siting flexibility that is an inherent part of all our boilers. The Ideal HE range comes with a choice of concentric or twin-pipe fluing options.

Twin-pipe fluing

Various twin-pipe options are available, in both 80mm and 60mm diameters, to assist in the termination of the flue where the boiler is installed in a location remote to an outside wall. These options allow for separation of the air supply from the pipe that discharges the flue gases.

80mm twin-pipe system

The maximum combined flue length is 46 metres. The following graph (FIG. 1) demonstrates the allowable lengths for the air supply and flue gas pipes. This system can be used for both horizontal and vertical applications.

60mm twin-pipe system

The maximum combined flue length is 20 metres. The following graph (FIG. 2) demonstrates the allowable lengths for the air supply and flue gas pipes. This system can be used for horizontal applications only.

Concentric flue systems

Maximum flue lengths:-

icos HE	HORIZONTAL *	6m	VERTICAL *	8m	POWERED VERTICAL *	14m
icos system HE		6m		8m		14m

*Each 90° elbow used is at the expense of 1000mm of straight flue run, and each 45° elbow is used at the expense of 600mm of straight flue run.

Twin-pipe systems

FIG. 1 Air and flue length combination graph
80mm twin flue system

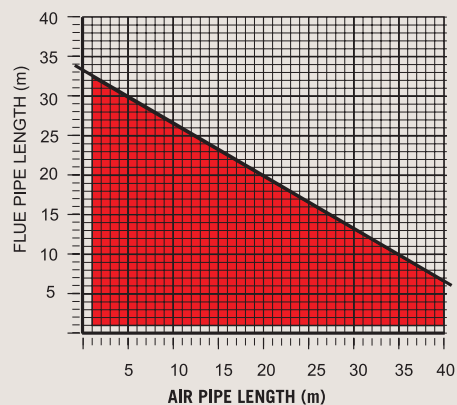
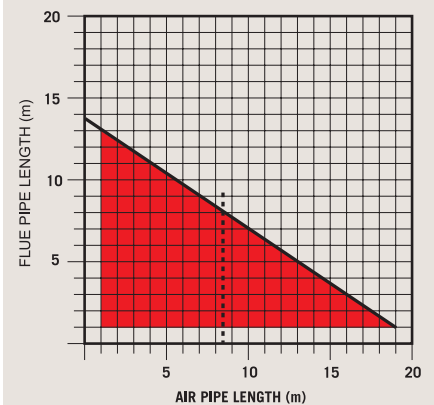

FIG. 2 Air and flue length combination graph
60mm twin flue system



Siting flexibility

There are a substantial number of fluing options available with our boilers, each giving excellent siting flexibility for almost all applications. These options include components such as roof flue and powered vertical flue kits which ensure that the installer encounters minimum restrictions.

Solutions for all applications

The Ideal range of fluing components has been planned to provide the installer with a choice of options which is capable of covering every application. Systems are available as 100mm concentric and a choice of 80mm or 60mm twin-pipe.

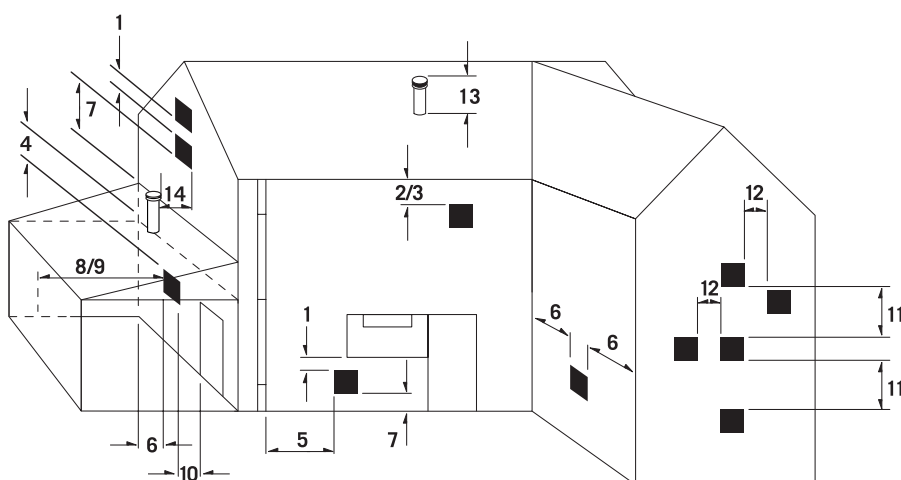

All flue systems must be inclined at a minimum of 1.5 degrees to the horizontal to allow condensate to be properly drained.

Minimum dimensions of flue terminal positions

KEY TO ILLUSTRATION

Terminal Position	Fan Models Min. Spacing
1 Directly below an openable window or other opening e.g. air brick	300mm
2 Below gutters, drain pipes or soil pipes	25mm*
3 Below eaves	25mm*
4 Below balconies or car port roof	25mm*
5 From vertical drain pipes or soil pipes	25mm*
6 From an internal or external corner or to a boundary alongside the terminal	25mm*
7 Above ground, roof or balcony level	300mm
8 From a surface or a boundary facing a terminal	600mm
9 From a terminal facing a terminal	1200mm
10 From an opening in a car port into a dwelling	1200mm
11 Vertically from a terminal on the same wall	1500mm
12 Horizontally from a terminal on the same wall	300mm
Vertical flues	
13 Above a pitched or flat roof (to base of terminal)	300mm
14 From adjacent wall to flue	1000mm

Table corresponds to BS5440: Part 1 : 2000
It must always be borne in mind that the HE range flues plume and that special consideration should be given to terminal position, except where marked*

ICOS HE AND ICOS SYSTEM HE - FLUE OPTIONS & ACCESSORIES

Concentric Flue Kits		Part No.	Twin-pipe flue terminal 125mm	158518
Standard flue (Pack B: 530mm long)		158222	Vertical twin-pipe flue terminal 125mm diameter	158519
Flue extension kit 60/100mm (Pack D: 1000mm long)		155987	Universal weather collar 125mm	158520
Roof flue kit		152254	Flat roof weather collar 125mm	158521
Powered vertical flue kit		152255	Slip coupling (80mm)	201157
45° Elbow kit 60/100mm diameter (pair)		152256		
Universal weather collar 100mm diameter		152258		
Flat roof weather collar 100mm diameter		152259		
Secondary flue extension pipe (pair)		152260		
Powered vertical flue terminal		152378		
90° Flue elbow kit 60/100mm		154187		
Flue finishing kit		155988		
Vertical connector		156405		
80mm Twin-pipe System		Part No.	60mm Twin-pipe system	Part No.
Secondary flue extension pipe (pair)		152260	Twin-pipe flue connector 60mm	200092
45° Elbow kit 80mm diameter (pair)		152810	Horizontal flue terminal 60mm	200093
Twin-pipe flue connector		158398	Horizontal air terminal 60mm	200094
90° Elbow kit 80mm		158399	Extension pipes 60mm (pair)	200095
Horizontal flue terminal 80mm		158400	90° Elbow kit 60mm	200096
Horizontal air terminal 80mm		158401	45° Elbow kit 60mm (pair)	200097
Loft terminal air grille 80mm		158403	Horizontal twin-pipe flue terminal 100mm	200112
Ridge tile flue terminal 80mm		158415	Slip coupling (60mm)	201156
			Accessories	Part No.
			Stand-off kit icos	156111
			Stand-off kit icos system	156190
			S-pack syphon kit	156331
			Valve cover kit icos/icos system	159973
			Condensate pump kit	159991
			Remote user control kit	200719

fluing options

Horizontal concentric - 100mm diameter

Please note that the following fluing options are relevant to the icos and icos system high-efficiency products.

Our maximum flue length is 6 metres (horizontal). Deduct 1 metre for each 90° bend and 0.6 metre for each 45° bend.

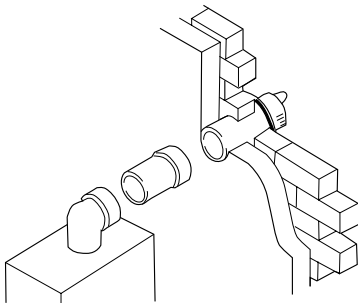

HORIZONTAL FLUE

Flue	Part Number	Maximum straight flue length (mm)
Standard pack B	158222	Right } Left } 650 Rear }
Standard pack B + Extension pack D	158222 155987	Right } Left } 1600 Rear }
Standard pack B + 2 x Extension pack D	158222 2 x 155987	Right } Left } 2550 Rear }
Standard pack B + 3 x Extension pack D	158222 3 x 155987	Right } Left } 3500 Rear }
Standard pack B + 4 x Extension pack D	158222 4 x 155987	Right } Left } 4450 Rear }
Standard pack B + 5 x Extension pack D	158222 5 x 155987	Right } Left } 5400 Rear }
Standard pack B + 6 x Extension pack D	158222 6 x 155987	Right } Left } 6000 Rear }

Note: Lengths are from centre line of boiler outlet to outside wall face. Where extension D packs are cut to length, flared end connector must be retained.

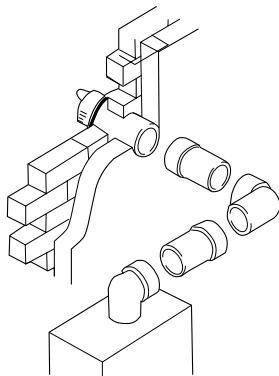

HORIZONTAL FLUE WITH 1 x 90° ELBOW

Flue	Part Number	Maximum straight flue length (mm)
Standard pack B + 90° Elbow	158222 154187	Right } Left } 830 Rear }
Standard pack B + Extension pack D + 90° Elbow	158222 155987 154187	Right } Left } 1780 Rear }
Standard pack B + 2 x Extension pack D + 90° Elbow	158222 2 x 155987 154187	Right } Left } 2730 Rear }
Standard pack B + 3 x Extension pack D + 90° Elbow	158222 3 x 155987 154187	Right } Left } 3680 Rear }
Standard pack B + 4 x Extension pack D + 90° Elbow	158222 4 x 155987 154187	Right } Left } 4630 Rear }
Standard pack B + 5 x Extension pack D + 90° Elbow	158222 5 x 155987 154187	Right } Left } 5000 Rear }

Note: Lengths are sum of all straight lengths between centre lines/outside wall face. Numbers of extension D packs give flexibility of lengths of straight at either side of elbow. Where extension D packs are cut to length, flared end connector must be retained.

HORIZONTAL FLUE WITH 2 x 90° ELBOW

Flue	Part Number	Maximum straight flue length (mm)
Standard pack B + 2 x 90° Elbow	158222 2 x 154187	Right } Left } 1010 Rear }
Standard pack B + Extension pack D + 2 x 90° Elbow	158222 155987 2 x 154187	Right } Left } 1960 Rear }
Standard pack B + 2 x Extension pack D + 2 x 90° Elbow	158222 2 x 155987 2 x 154187	Right } Left } 2910 Rear }
Standard pack B + 3 x Extension pack B + 2 x 90° Elbow	158222 3 x 155987 2 x 154187	Right } Left } 3860 Rear }
Standard pack B + 4 x Extension pack D + 2 x 90° Elbow	158222 4 x 155987 2 x 154187	Right } Left } 4000 Rear }

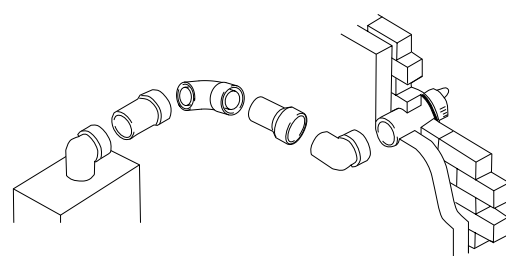

Note: Lengths are sum of all straight lengths between centre lines/outside wall face.
Numbers of extension D packs give flexibility of lengths of straight at either side of elbows.
Where extension D packs are cut to length, flared end connector must be retained.

HORIZONTAL FLUE WITH 2 x 45° ELBOW

Flue	Part Number	Maximum straight flue length (mm)
Standard pack B + 2 x 45° Elbow	158222 152256	Right } Left } 850 Rear }
Standard pack B + 2 x 45° Elbow + Extension pack D	158222 152256 155987	Right } Left } 1800 Rear }
Standard pack B + 2 x 45° Elbow + 2 x Extension pack D	158222 152256 2 x 155987	Right } Left } 2750 Rear }
Standard pack B + 2 x 45° Elbow + 3 x Extension pack D	158222 152256 3 x 155987	Right } Left } 3700 Rear }
Standard pack B + 2 x 45° Elbow + 4 x Extension pack D	158222 152256 4 x 155987	Right } Left } 4650 Rear }
Standard pack B + 2 x 45° Elbow + 5 x Extension pack D	158222 152256 5 x 155987	Right } Left } 4800 Rear }

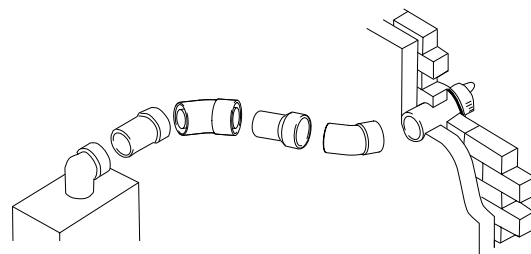

Note: Lengths are sum of all straight lengths between centre lines/outside wall face.
Numbers of extension D packs give flexibility of lengths of straight at either side of elbows.
Where extension D packs are cut to length, flared end connector must be retained.

fluing options

Maximum flue length for all models is 8 metres.

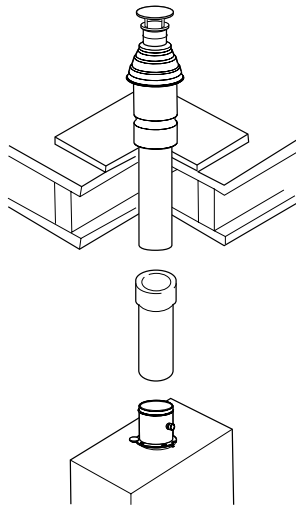

ROOF FLUE SYSTEM

Flue	Part Number	Maximum straight flue length (mm)	
Roof Flue Kit + Vertical Connector + Weather Collar	152254 156405 152258/152259*	1050	
Roof Flue Kit + Vertical Connector + Extension Pack D + Weather Collar	152254 156405 155987 152258/152259*		2000
Roof Flue Kit + Vertical Connector + 7 (maximum) x Extension Pack D + Weather Collar	152254 156405 7 x 155987 152258/152259*		

Note*: 152258: universal weather collar (suits any roof pitch).
152259: flat roof weather collar.

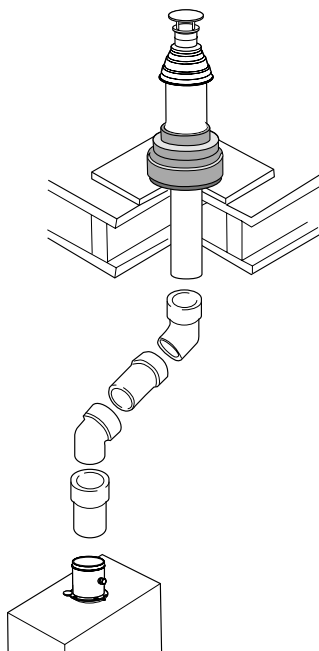

ROOF FLUE SYSTEM WITH 2 X 45° ELBOW

Flue	Part Number	Maximum straight flue length (mm)
Roof Flue Kit + Vertical Connector + 6 (maximum) x Extension Pack D + 2 x 45° Elbow + Weather Collar	152254 156405 6 x 155987 152256 152258/152259*	6800

Note*: 152258: universal weather collar (suits any roof pitch).
152259: flat roof weather collar.

POWERED VERTICAL FLUE SYSTEM

Flue	Part Number	Maximum straight flue length (mm)
Powered Vertical Flue Kit	152255	Primary: 8000 Secondary: 6000
+ Vertical Connector	156405	
+ Powered Vertical Flue Terminal	152378	
+ Weather Collar	152258/152259*	
+ 8 (maximum) x Extension Pack D	8 x 155987	
+ 6 (maximum) x Secondary Flue Extension Pipe† (pairs)	3 x 152260	

Notes*:

Allows the boiler to be sited in a position where no access to an outside wall is available. Permits the concentric flue to run vertically from the top of the boiler and obtain air supply within the roof space, the secondary flue continuing to the external flue terminal.

Maximum primary flue length of up to 8 metres. Up to 8 flue extension kits (pack D) may be required. Maximum secondary flue length up to 6 metres.

Offset applications are permissible though the maximum length is reduced.

* 152258: universal weather collar (suits any roof pitch).
 152259: flat roof weather collar.

† Installer to provide pipework for condensate drain on powered vertical flue kit.

Where extension D packs are cut to length, the flared end connector must be retained.

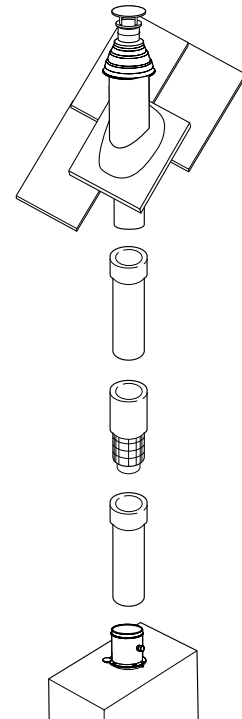

fluing options

Twin-pipe 80 mm diameter

Our maximum combined flue length is 46 metres. Deduct 5.3 metres for each 90° bend and 3.3 metres for each 45° bend.

Twin-pipe 60 mm diameter

Our maximum combined flue length is 20 metres. Deduct 1.25 metres for each 90° bend and 0.8 metres for each 45° bend.

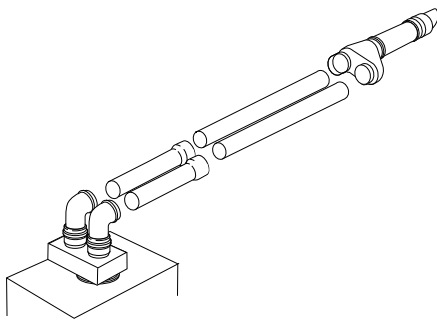

HORIZONTAL TWIN FLUING-TO HORIZONTAL TWIN-PIPE FLUE TERMINAL

Flue	Part Number		Maximum straight flue length (mm)
	(80 mm)	(60 mm)	
Twin-pipe Flue Connector	158398	200092	Refer to the relevant air and flue length combination graph (page 14 FIG. 1 or FIG. 2) for maximum straight flue length and reduce for elbows accordingly
Flue extension pipe (including support brackets)	152260	200095	
45° Elbow Kit (where required)	152810	200097	
90° Elbow Kit (where required)	158399	200096	
Horizontal Twin-pipe Flue Terminal (80mm flue only)	158518	see note	

Note: Use 100mm standard B pack (part number 158222) plus Adaptor Twin Flue 60mm (part number 200112), shown page 31.

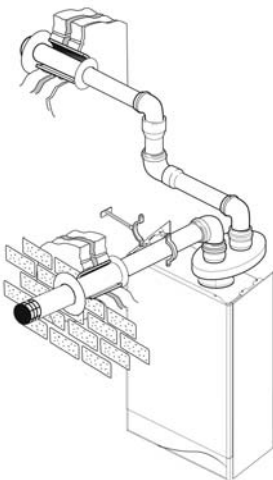

HORIZONTAL TWIN FLUING-HORIZONTAL FLUE & AIR TERMINALS

Flue	Part Number		Maximum straight flue length (mm)
	(80 mm)	(60 mm)	
Twin-pipe Flue Connector	158398	200092	Refer to the relevant air and flue length combination graph (page 14 FIG. 1 or FIG. 2) for maximum straight flue length and reduce for elbows accordingly
Flue extension pipe (including support brackets)	152260	200095	
45° Elbow Kit (where required)	152810	200097	
90° Elbow Kit (where required)	158399	200096	
Horizontal Flue Terminal	158400	200093	
Horizontal Air Terminal	158401	200094	

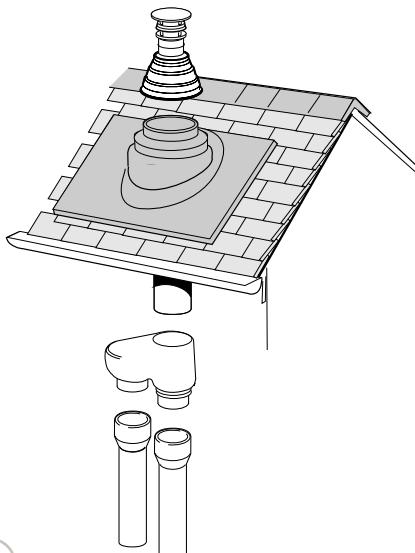

VERTICAL FLUE ARRANGEMENT-TO VERTICAL TWIN-PIPE FLUE TERMINAL

Flue	Part Number (80 mm)	Maximum straight flue length (mm)
Twin-pipe Flue Connector	158398	Refer to the relevant air and flue length combination graph (page 14 FIG. 1 or FIG. 2) for maximum straight flue length and reduce for elbows accordingly
Flue extension pipe (including support brackets)	152260	
45° Elbow Kit (where required)	152810	
90° Elbow Kit (where required)	158399	
Vertical Twin-pipe Flue Terminal 125mm diameter	158519	
Weather Collar-125mm diameter	158520/158521	

VERTICAL/HORIZONTAL FLUE ARRANGEMENT-HORIZONTAL AIR TERMINAL & VERTICAL FLUE TERMINAL

Flue	Part Number (80mm)	Maximum straight flue length (mm)
Twin-pipe Flue Connector	158398	Refer to the relevant air and flue length combination graph (page 14 FIG. 1 or FIG. 2) for maximum straight flue length and reduce for elbows accordingly
Flue extension pipe (including support brackets)	152260	
45° Elbow Kit (where required)	152810	
90° Elbow Kit (where required)	158399	
Vertical Flue Terminal 100mm diameter	152378	
Weather Collar-100mm diameter	152258/152259	
Horizontal Air Terminal	158401	

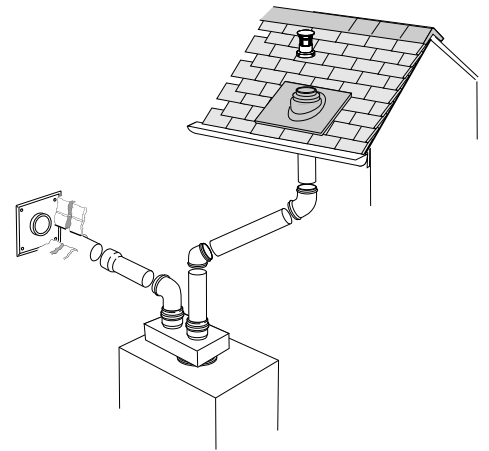

VERTICAL FLUE ARRANGEMENT-LOFT TERMINAL & VERTICAL FLUE TERMINAL

Flue	Part Number (80mm)	Maximum straight flue length (mm)
Twin-pipe Connector	158398	Refer to the relevant air and flue length combination graph (page 14 FIG. 1 or FIG. 2) for maximum straight flue length and reduce for elbows accordingly
Flue extension pipe (including support brackets)	152260	
45° Elbow Kit (where required)	152810	
90° Elbow Kit (where required)	158399	
Vertical Flue Terminal 100mm diameter	152378	
Weather Collar-100mm diameter	152258/152259	
Loft Terminal Air Grille	158403	

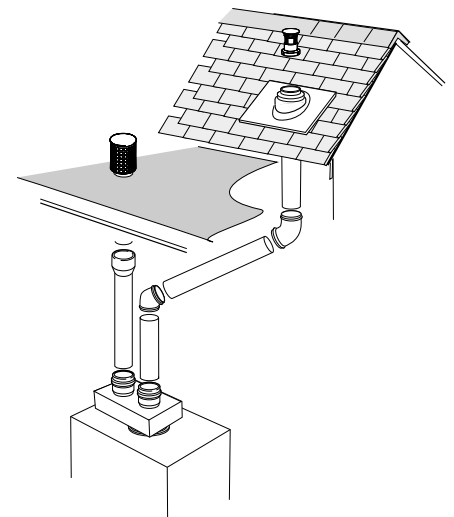

VERTICAL FLUE ARRANGEMENT-LOFT TERMINAL & RIDGE TILE FLUE TERMINAL

Flue	Part Number (80mm)	Maximum straight flue length (mm)
Twin-pipe Flue Connector	158398	Refer to the relevant air and flue length combination graph (page 14 FIG. 1 or FIG. 2) for maximum straight flue length and reduce for elbows accordingly
Flue extension pipe (including support brackets)	152260	
45° Elbow Kit (where required)	152810	
90° Elbow Kit (where required)	158399	
Ridge Tile Flue Terminal	158415	
Weather Collar-100mm diameter	152258/152259	
Loft Terminal Air Grille	158403	

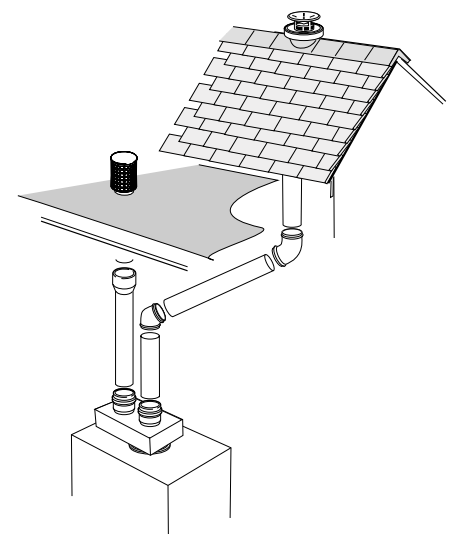

extras and accessories

There are many extras and accessories available for use with all the Ideal appliances. All are competitively priced and readily available.

Flue pack D

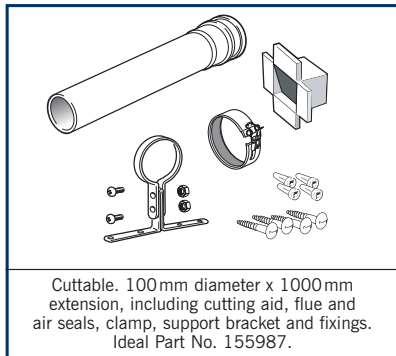

Cuttable. 100 mm diameter x 1000 mm extension, including cutting aid, flue and air seals, clamp, support bracket and fixings. Ideal Part No. 155987.

Flue finishing kit

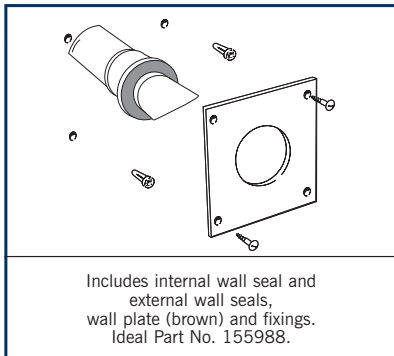

Includes internal wall seal and external wall seals, wall plate (brown) and fixings. Ideal Part No. 155988.

Vertical terminal

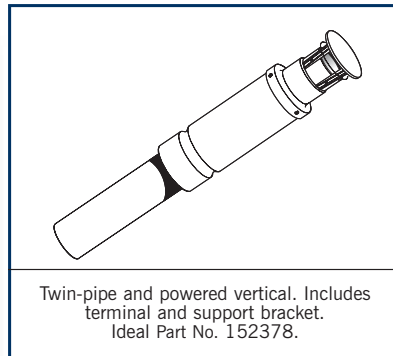

Twin-pipe and powered vertical. Includes terminal and support bracket. Ideal Part No. 152378.

90° Elbow kit - 100 mm diameter

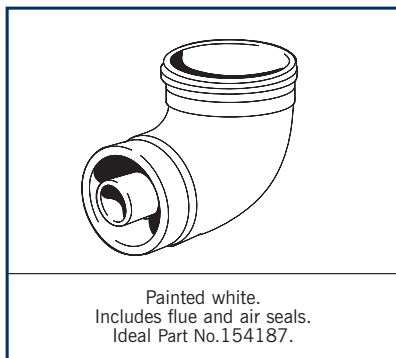

Painted white. Includes flue and air seals. Ideal Part No. 154187.

45° Elbow kit - 100 mm diameter

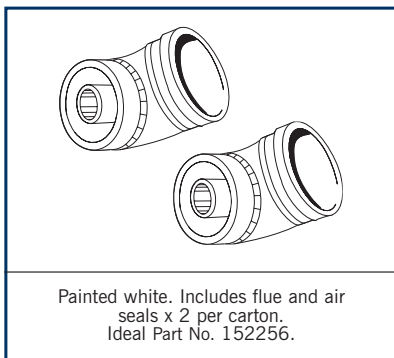

Painted white. Includes flue and air seals x 2 per carton. Ideal Part No. 152256.

Flue extension pipe

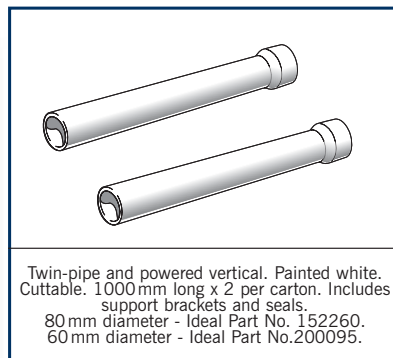

Twin-pipe and powered vertical. Painted white. Cuttable. 1000 mm long x 2 per carton. Includes support brackets and seals. 80 mm diameter - Ideal Part No. 152260. 60 mm diameter - Ideal Part No. 200095.

Vertical flue connector

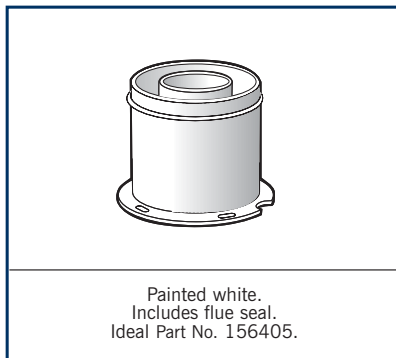

Painted white. Includes flue seal. Ideal Part No. 156405.

Vertical powered flue kit



Includes air inlet grille, adaptor, condensate trap, flue extension and clamp. Ideal Part No. 152255.

Roof flue kit

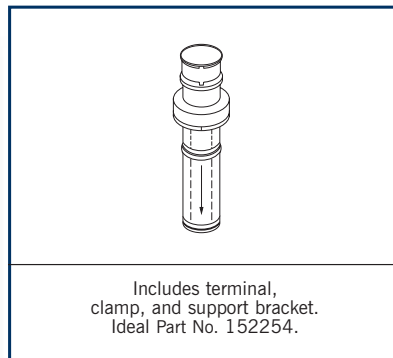

Includes terminal, clamp, and support bracket. Ideal Part No. 152254.

90° Elbow kit (twin-pipe)

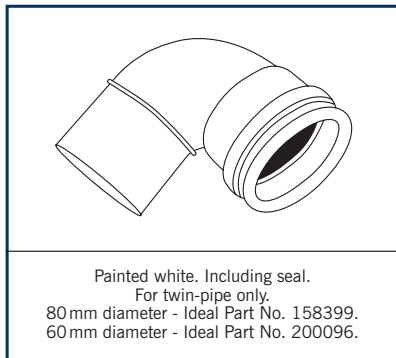

Painted white. Including seal. For twin-pipe only. 80 mm diameter - Ideal Part No. 158399. 60 mm diameter - Ideal Part No. 200096.

45° flue elbow (twin-pipe)

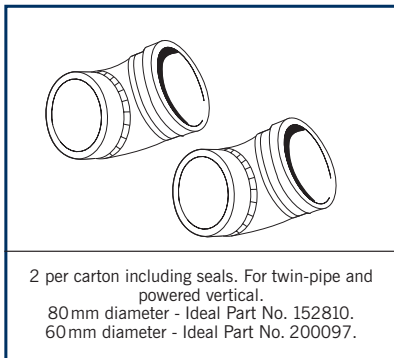

2 per carton including seals. For twin-pipe and powered vertical. 80 mm diameter - Ideal Part No. 152810. 60 mm diameter - Ideal Part No. 200097.

Horizontal twin-pipe flue terminal - 125 mm diameter

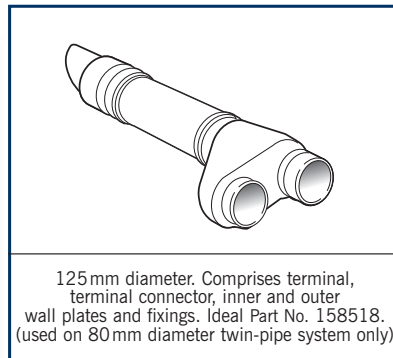

125 mm diameter. Comprises terminal, terminal connector, inner and outer wall plates and fixings. Ideal Part No. 158518. (used on 80 mm diameter twin-pipe system only)

Vertical twin-pipe flue terminal

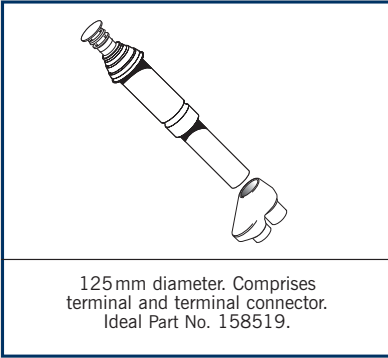

125 mm diameter. Comprises terminal and terminal connector.
Ideal Part No. 158519.

Twin-pipe flue connector

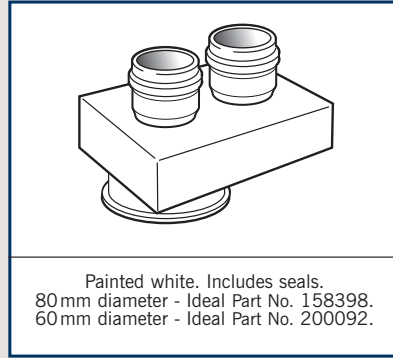

Painted white. Includes seals.
80 mm diameter - Ideal Part No. 158398.
60 mm diameter - Ideal Part No. 200092.

Horizontal flue terminal

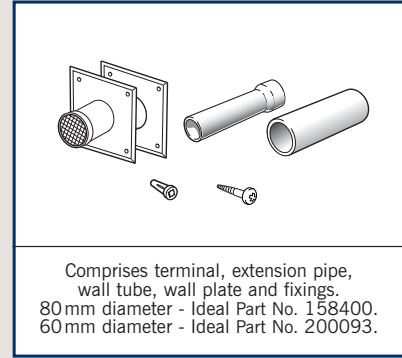

Comprises terminal, extension pipe, wall tube, wall plate and fixings.
80 mm diameter - Ideal Part No. 158400.
60 mm diameter - Ideal Part No. 200093.

Horizontal air terminal (twin-pipe)

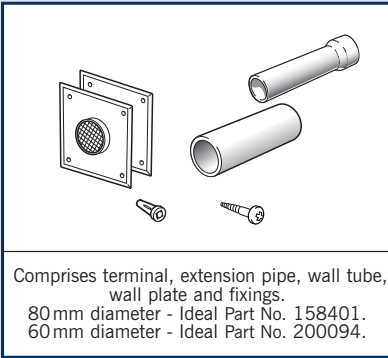

Comprises terminal, extension pipe, wall tube, wall plate and fixings.
80 mm diameter - Ideal Part No. 158401.
60 mm diameter - Ideal Part No. 200094.

Loft terminal air grille (twin-pipe)

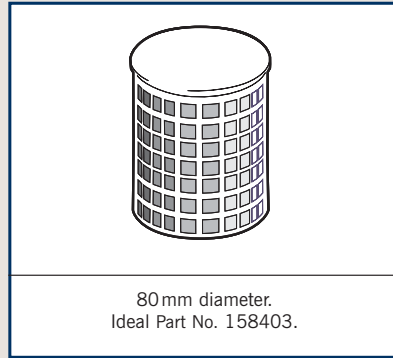

80 mm diameter.
Ideal Part No. 158403.

Ridge tile flue terminal (twin-pipe)

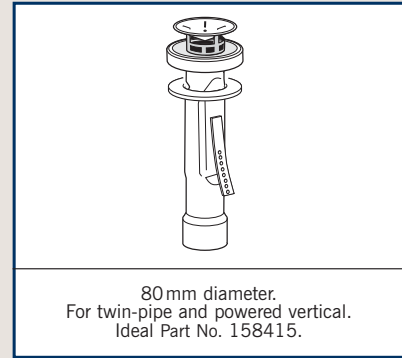

80 mm diameter.
For twin-pipe and powered vertical.
Ideal Part No. 158415.

Weather collar – flat roof

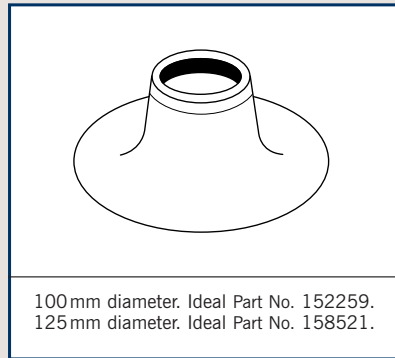

100 mm diameter. Ideal Part No. 152259.
125 mm diameter. Ideal Part No. 158521.

Weather collar – universal

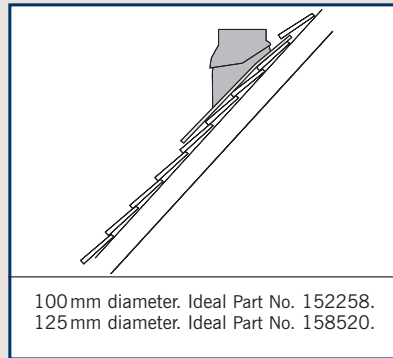

100 mm diameter. Ideal Part No. 152258.
125 mm diameter. Ideal Part No. 158520.

Horizontal twin-pipe flue terminal 100mm diameter

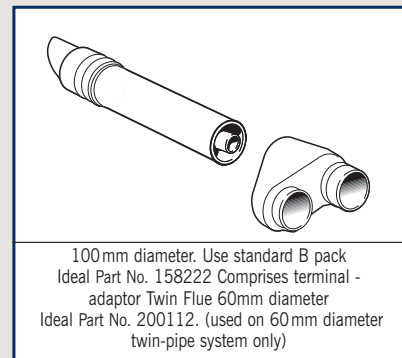

100 mm diameter. Use standard B pack
Ideal Part No. 158222 Comprises terminal - adaptor Twin Flue 60mm diameter
Ideal Part No. 200112. (used on 60 mm diameter twin-pipe system only)

Remote user control kit

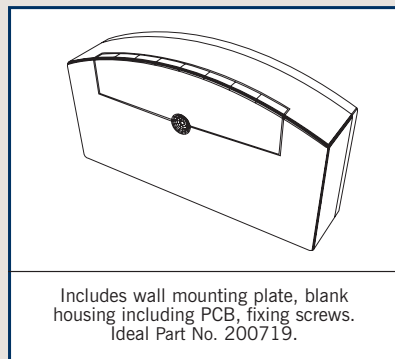

Includes wall mounting plate, blank housing including PCB, fixing screws.
Ideal Part No. 200719.

Stand-off kits

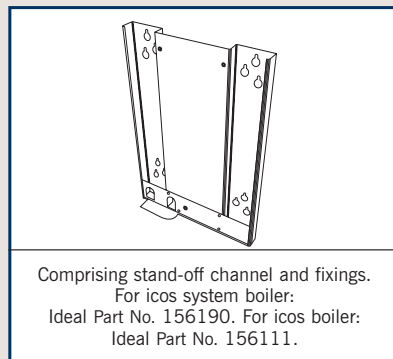

Comprising stand-off channel and fixings.
For icos system boiler:
Ideal Part No. 156190. For icos boiler:
Ideal Part No. 156111.

S-Pack syphon kit

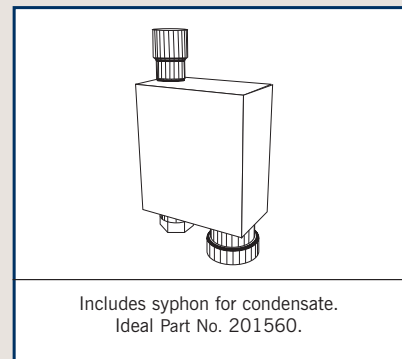

Includes syphon for condensate.
Ideal Part No. 201560.

Valve cover kit

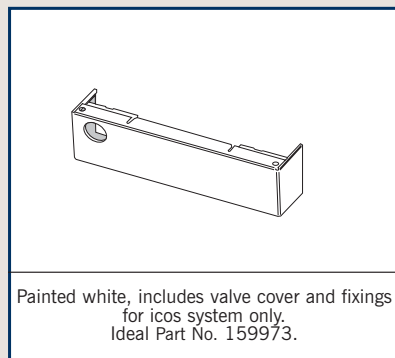

Painted white, includes valve cover and fixings for icos system only.
Ideal Part No. 159973.

Condensate Pump Kit

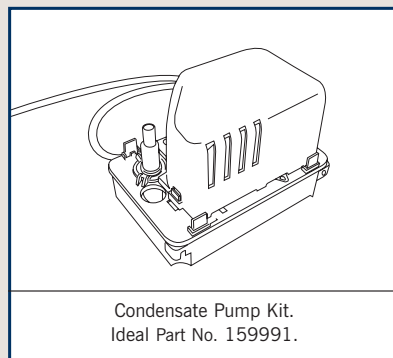

Condensate Pump Kit.
Ideal Part No. 159991.

Flue-slip coupling

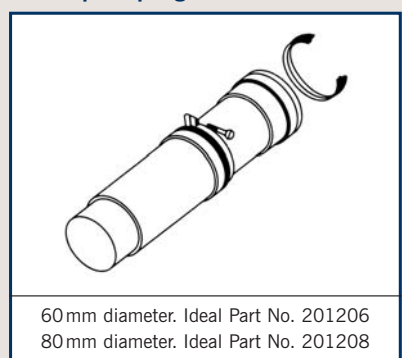

60 mm diameter. Ideal Part No. 201206
80 mm diameter. Ideal Part No. 201208



classic HE

The classic HE boiler is a high-efficiency development of the well known classic SE range. It fully complies with the latest requirements of Building Regulations Part L, yet still maintains the simplicity and ruggedness that its predecessor is renowned for. By using the minimum number of additional components with the famed cast iron heat exchanger and overall layout, ease of installation and servicing has been retained but now in high-efficiency form.

A range of outputs, including LPG models, together with a range of fluing options, makes the classic HE the choice for more installations. Particularly now all models fit behind a cupboard door.

Application and usage

The classic HE has been developed to be the boiler of choice for new housing or older systems where replacement or upgrades are required. Its attractive, compact design, simple controls and quiet operation means it can be sited anywhere in the house. A downward piping kit allows system pipes to be neatly concealed behind the boiler if required. Simple 3 core wiring means it is an easy replacement in older systems. Even the system pipe centres and rear flue outlet are in the same positions as the classic SE.

Flue options include a rear outlet neatly led from within the casing, whilst side outlet or vertical flues are easily installed.

Any issues of condensate drain routing can be overcome by using the optional Ideal condensate pump kit.

The classic HE in operation

All models are fan-flued, high-efficiency products with fixed outputs for simple operation. The normal cast iron heat exchanger is retained and a neat cast aluminium recuperator is fitted behind it. Robust simplicity is continued with the atmospheric burner using the intermittent pilot burner assembly. The user benefits from an adjustable thermostat control.

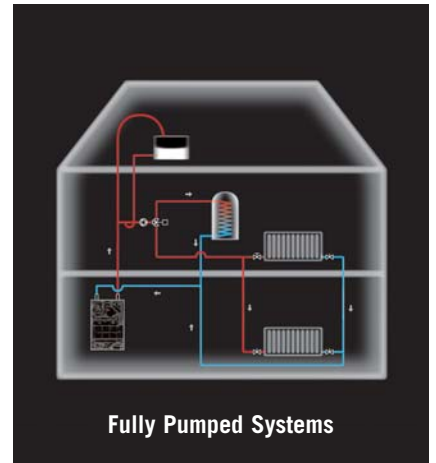

SEDBUK rating



classic HE - technical data

Roof or side flue outlets

Compact dimensions

height 700mm
width 380mm
depth 280mm

Fan

Secondary heat exchanger

(recuperator) cast aluminium for durability fitted behind main heat exchanger

Combustion chamber

Simple 3 core electrical connections

Air pressure switch

Rear flue outlet (from casing rear)

Cast iron primary heat exchanger

Atmospheric burner

Adjustable thermostat

On/off switch

Condensate syphon outlet

PERFORMANCE DATA

Model		9	12	15	18	15P	18P
Output	kW	9.0	12.0	15.0	18.0	15.0	18.0
	Btu/h	30,700	40,900	51,200	61,400	51,200	61,400

Note: 'P' as in 15P denotes propane gas model. All other models natural gas.

INSTALLATION DATA

Model		9	12	15	18	15P	18P
Gas supply connection		Rc ½ (½" BSP female)					
Flow connection		22mm copper					
Return connection		22mm copper					
Electrical supply		230V / 50Hz (boiler power consumption 100W)					
Fuse rating		External 3A Internal F1A to BS 4265					
Water content	L	3.0	3.0	3.95	3.95	3.95	3.95
Max. install. weight	kg	40	40	45	45	45	45
Flue duct diameter	mm	100	100	100	100	100	100

CLEARANCE DATA

The following clearances are required for installation, servicing and replacement of parts.

Front of boiler	Sides	Top of boiler	Bottom of boiler
450mm	5mm	100mm	100mm

Note: front clearance can be reduced to 5mm behind panel, provided that the top and bottom of the casing is not enclosed, and side clearance is 50mm at both sides. This product is not suitable for external installation. The wall on which the boiler is being mounted must be able to support its total weight. The wall will not require special protection, but if the unit is being fitted in a timber-frame building the guidelines set out in IGE/UP/7:1998 should be observed.

PIPEWORK CONNECTIONS AND PRODUCT DIMENSIONS

Flue plumbing is a by-product of efficiency. Please be aware of terminal positions to avoid complaints (see page 33, fluing options).

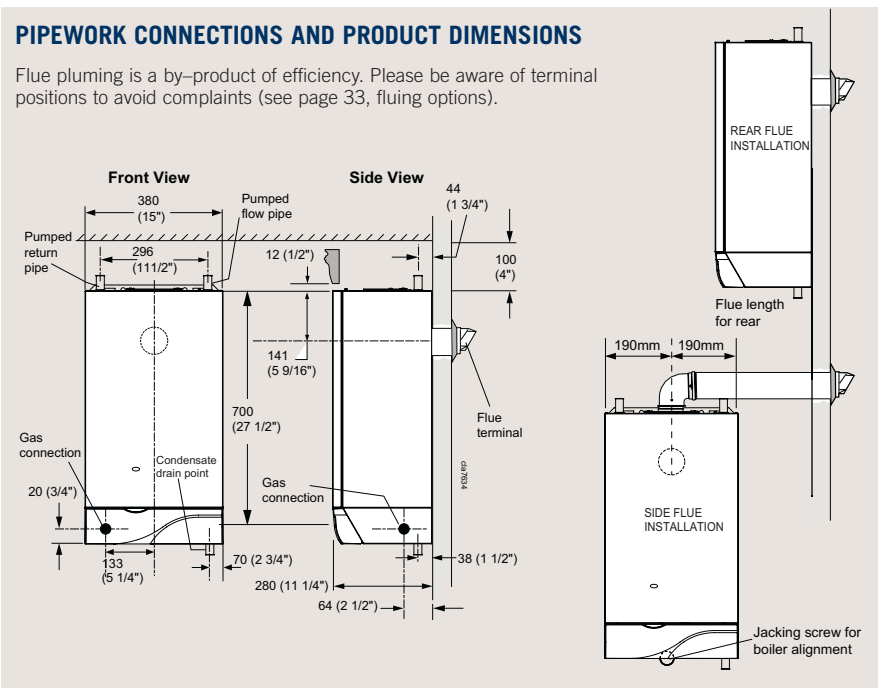

For full technical details please refer to the Installation and Servicing Instructions provided with the product.

The Ideal wall-hung cast iron, high-efficiency boiler

Installation tips

Ideal recommend that a minimum heating load of 10% of heating output be controlled using a room thermostat, leaving all other rooms capable of being controlled by TRVs.

The boiler has a cast aluminium alloy recuperator, therefore suitable water treatment should be applied to the system.

Siting options

Compact dimensions and optional rear, side or top flue outlets, allow the classic HE to readily fit more installations.



SEDBUK rating





mexico HE

The Ideal high-efficiency floor standing boiler range

The mexico HE boiler provides the optimum solution, whether it's a new installation, where an old floor standing boiler is being replaced, or just a bigger output is needed. An advanced high-efficiency range from the leading floor standing boiler supplier brings the reassurance of proven reliability from current Ideal boilers (robust, system friendly cast aluminium) together with experience built over decades of mexico sales.

Compact and stylish yet simple to operate. The result is appliances both easy to install and which require minimal servicing and maintenance. For the homeowner it's a low running cost boiler that can be fitted with minimum change and offers years of trouble free service.

Application and usage

Compact size, flexibility of siting, ease of installation and advanced reliability all means that the mexico HE suits more households. Designed to make new boiler installations or replacements faster and simpler, a pre-piping frame allows system and gas connections to be made before sliding the boiler into position. No cupboard ventilation means it readily fits comfortably under worktops and behind cupboard doors to make the neatest installations. But its good looks makes stand alone use just as satisfactory. A range of flue options, both horizontal and vertical, gives more options to siting the boiler.

Any issues of condensate drain routing may be overcome by using the optional Ideal condensate pump kit, which can be fitted inside the boiler casing if required.

The mexico HE in operation

All models are automatically controlled, fan-flued high-efficiency products. Heat output is modulated to match the demands of the heating load for maximum efficiency and low running costs.

The readily visible control panel provides temperature control with a status display, including diagnostics for rapid servicing. The optional remote user kit allows the panel to be sited in the most convenient position for the customer.

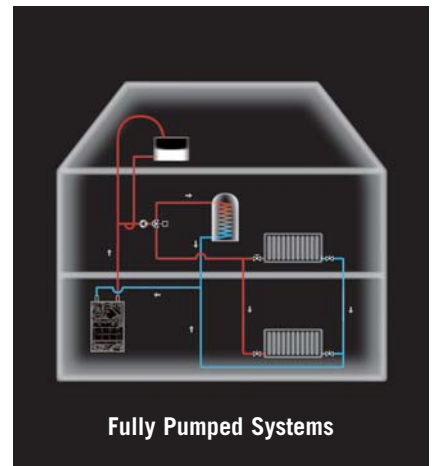

SEDBUK rating



mexico HE - technical data

Compact dimensions

height 850mm
width 450mm
depth 530mm

Easy access terminal connections

Fully modulating product with gas/air pre-mixed at fan

Downward firing pre-mix burner

Heat exchanger (cast aluminium) provides low lift weights for easy installation and good system operation

'Self-adjusting' feature reduces time and installation cost, making installation much simpler

No compartment ventilation required and fits behind a standard kitchen cupboard door, providing siting flexibility

Top, rear or side flue outlets

Alpha-numeric display provides operation status. Also gives fault codes for rapid diagnosis in the unlikely event of a problem.

Control panel pulls forward and hinges down for ready access to PCB and connections

Automatic air vent

Built in condensate 'S' trap

Pre-piping frame for fast and easy installation

Gas Flow Return

Connections readily accessible

PERFORMANCE DATA

Model	HE 15	HE 18	HE 24	HE 30	HE 36
Output kW	8.8 - 14.6	8.8 - 18.2	8.8 - 23.4	10.6 - 30.1	10.6 - 37.0
Btu/h	30,000 - 50,000	30,000 - 62,300	30,000 - 80,000	36,200 - 102,700	36,200 - 126,200

INSTALLATION DATA

Model	HE 15	HE 18	HE 24	HE 30	HE 36	
Gas supply connection	inches			Rc 1/2		
Flow connection	mm			22 compression*		
Return connection	mm			22 compression*		
Condensate drain	mm			21.5		
Maximum static	m			30.5		
Electrical supply	V/Hz			230 / 50		
Power consumption	W	38	38	38	42	42
Fuse rating	A			3		
Water content	L	2.0	2.0	2.0	4.7	4.7
Max installation weight	kg	47	47	47	67	67
Total packed weight	kg	54	54	54	74	74
Flue terminal diameter	mm			100		

CLEARANCE DATA

The following clearances are required for installation, servicing and replacement of parts.

Front of boiler	Sides	Top of boiler
450mm*	5mm	20mm

*Minimum clearance required at front of boiler for servicing is 450mm. When built in behind a concealing panel this may be reduced to 5mm.

Note: This product is not suitable for external installation. If the boiler is to be fitted in a timber framed building it should be fitted in accordance with the Institute of Gas Engineers document IGE/UP7:1998.

The Ideal floor standing high-efficiency boiler

Installation tips

Ideal recommend that a minimum heating load of 3,000 Btu/h be controlled using a room thermostat, leaving all other rooms capable of being controlled by TRVs.

The boiler has a cast aluminium alloy heat exchanger, therefore suitable water treatment should be applied to the system.

Siting options

It can be fitted under a worktop, behind a cupboard door and with no ventilation required. Optional remotely mountable user controls, compact dimensions and a highly flexible fluing system allow the mexico HE to be easily sited.

PIPEWORK CONNECTIONS AND PRODUCT DIMENSIONS

Flue plumbing is a by-product of efficiency. Please be aware of terminal positions to avoid complaints (see page 33, fluing options).

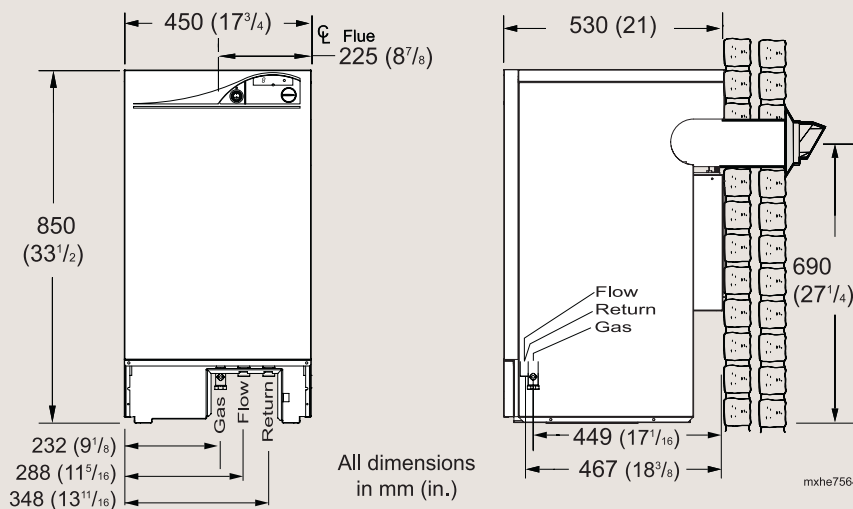

For full technical details please refer to the Installation and Servicing Instructions provided with the product.

SEDBUK rating



classic HE & mexico



The classic HE

The classic HE benefits from a range of flue options and the maximum flue lengths are as follows:-

Horizontal	(rear)	0.705m
Horizontal	(side)	3m
Vertical		tbc

Note: Each 90° elbow used is at the expense of 1000mm of straight flue run, and each 45° elbow is used at the expense of 750mm of straight flue run.

The mexico HE

The mexico HE benefits from a range of flue options and maximum flue lengths permissible are as follows:-

	HE 15/18/24	HE 30/36
Horizontal	6m	3m
Vertical	8m	5m

Note: Each 90° elbow used is at the expense of 1000mm of straight flue run, and each 45° elbow is used at the expense of 750mm of straight flue run.

HE fluing options

Siting flexibility

There are a substantial number of fluing options available with our boilers, each giving excellent siting flexibility for almost all applications. These options include components such as roof flue kits which ensure that the installer encounters minimum restrictions.

CLASSIC HE AND MEXICO HE - FLUE OPTIONS & ACCESSORIES

Concentric Flue Kits

	Part No.
Standard flue (Pack B: 775mm long)	201816
Flue extension kit 60/100mm (Pack D: 950mm long)	201180
Flue finishing kit (100mm diameter)	201181
Roof flue kit	201189
90° Flue elbow kit 60/100mm	201182
45° Elbow kit 60/100mm diameter (pair)	201183
Universal weather collar 125mm diameter	158431
Flat roof weather collar 125mm diameter	158432
Side outlet kit (classic HE only)	201866
Vertical connector kit (classic HE only)	201867
Vertical connector (mexico HE only)	201869
Vertical outlet kit (mexico HE only)	201871

Accessories - classic HE

	Part No.
Downward piping kit	201868
Condensate pump kit	159991

Accessories - mexico HE

	Part No.
Concealment panel kit	201895
Terminal wall plate kit	201896
Remote user control kit	200719
Condensate pump kit	159991

Minimum dimensions of flue terminal positions

KEY TO ILLUSTRATION

Terminal Position	Minimum Spacing	
	classic HE	mexico HE
1 Directly below an openable window or other opening e.g. air brick	300mm	300mm
2 Below gutters, drain pipes or soil pipes	75mm	25mm
3 Below eaves	200mm	25mm
4 Below balconies or car port roof	200mm	25mm
5 From vertical drain pipes or soil pipes	150mm	25mm
6 From an internal or external corner or to a boundary alongside the terminal	300mm	25mm
7 Above ground, roof or balcony level	300mm	300mm
8 From a surface or a boundary facing a terminal	600mm	600mm
9 From a terminal facing a terminal	1200mm	1200mm
10 From an opening in a car port into a dwelling	1200mm	1200mm
11 Vertically from a terminal on the same wall	1500mm	1500mm
12 Horizontally from a terminal on the same wall	300mm	300mm
Vertical flues		
13 Above a pitched or flat roof (to base of terminal)	300mm	300mm
14 From single wall face	600mm	600mm
From corner wall faces	1000mm	1000mm

Table corresponds to BS5440: Part 1 : 2000

It must always be borne in mind that the HE range flues plume and that special consideration should be given to terminal position, except where marked*

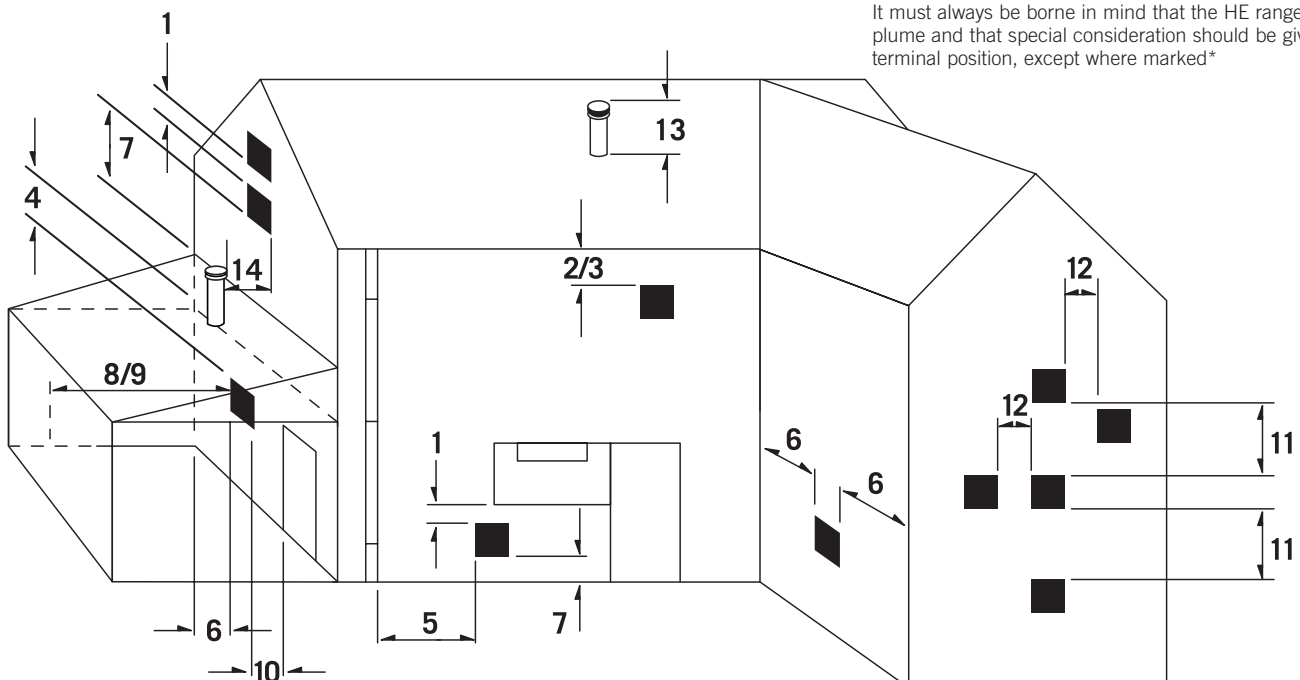

classic HE fluing options

Please note the following fluing options are relevant to classic HE boilers only.

Horizontal concentric

The flue duct must be inclined at a minimum of 1.5 degrees to the horizontal to allow condensate to be properly drained.

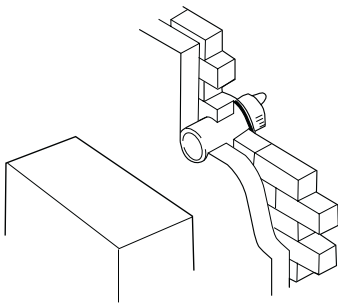

HORIZONTAL FLUE (FROM REAR OF BOILER)

Flue	Part Number	Maximum flue length (mm)
Standard pack B	201816	Rear: 705

HORIZONTAL SIDE FLUE

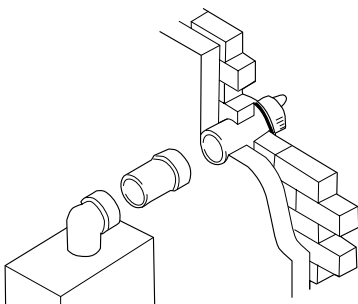

Flue	Part Number	Maximum flue length (mm)*
Side outlet kit + Standard pack B	201866 201816	775
Side outlet kit + Standard pack B + Extension pack D	201866 201816 201180	1680
Side outlet kit + Standard pack B + 2 x Extension pack D	201866 201816 2 x 201180	2585
Side outlet kit + Standard pack B + 3 x Extension pack D	201866 201816 3 x 201180	3000

* Measured from centre line of boiler to outside of wall.

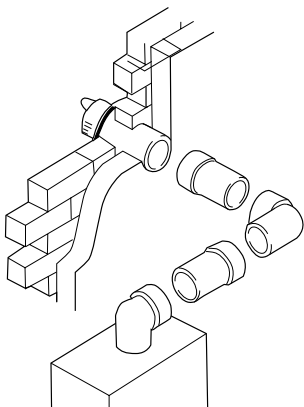

HORIZONTAL SIDE FLUE WITH 1 x 90° ELBOW

Flue	Part Number	Maximum flue length (mm)
Side outlet kit 90° elbow + 2 x Extension pack D + Standard pack B	201866 201182 201180 201816	2250

RAISED HORIZONTAL FLUE WITH 1 X 90° ELBOW

Flue	Part Number	Maximum flue length (mm)
Vertical connector kit	201867	2250
90° elbow	201182	
+ 2 x Standard pack B	2 x 201816	
+ Extension pack D	201180	

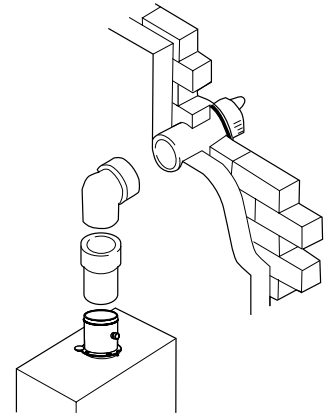

ROOF FLUE SYSTEM

Flue	Part Number	Maximum flue length (mm)
Vertical connector kit	201867	tbc
Roof flue kit	201189	
+ Weather collar	158431/158432*	
Vertical connector kit	201867	tbc
Roof flue kit	201189	
+ Extension pack D	201180	
+ Weather collar	158431/158432*	
Vertical connector kit	201867	tbc
Roof flue kit	201189	
+ 2 x Extension pack D	2 x 201180	
+ Weather collar	158431/158432*	

*Note: 158431: universal weather collar (suits any roof pitch);
158432: flat roof weather collar.

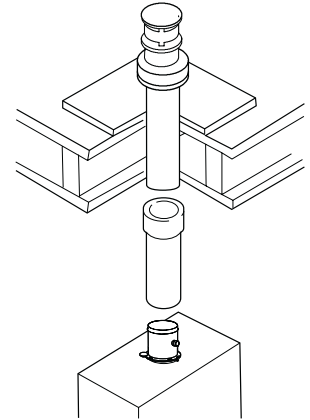

ROOF FLUE SYSTEM WITH 2 x 45° ELBOW

Flue	Part Number	Maximum flue length (mm)
Vertical connector kit	201867	tbc
Roof flue kit	201189	
+ 2 x 45° Elbow	1 x 201183	
+ 2 x Extension pack D	2 x 201180	
+ Weather collar	158431/158432*	

*Note: 158431: universal weather collar (suits any roof pitch);
158432: flat roof weather collar.

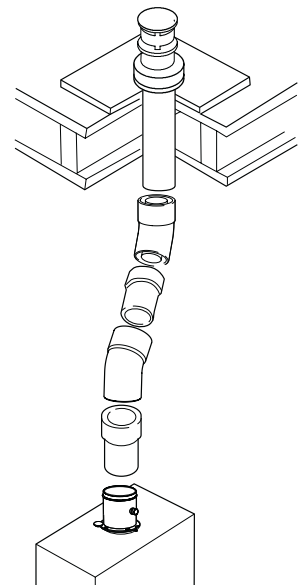

mexico HE fluing options

Please note the following fluing options are relevant to mexico HE boilers only.

Horizontal concentric

The flue duct must be inclined at a minimum of 1.5 degrees to the horizontal to allow condensate to be properly drained.

Maximum flue length is 6 metres for HE15/18/24 and 3 metres for HE30/36

Note: Lengths are measured from the flue elbow centre line. This position is as follows:

Rear outlet - 75mm from rear of jacket to flue centre line.

Side outlet - 225mm from boiler side panel to flue centre line

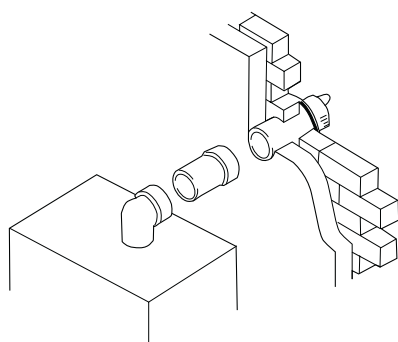

HORIZONTAL FLUE

Flue	Part Number	Maximum straight flue length (mm)
Standard pack B	201816	Right } Left } 775 Rear }
Standard pack B + 3 x Extension pack D	201816 3 x 201180	Right } Left } 3490* Rear }
Standard pack B + 6 x Extension pack D	201816 6 x 201180	Right } Left } 6000 Rear }

* Maximum HE 30 & 36 length is 3000mm

Note: Where extension D packs are cut to length, flared end connector must be retained.

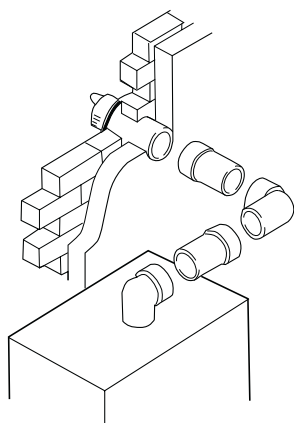

HORIZONTAL FLUE WITH 1 x 90° ELBOW

Flue	Part Number	Maximum straight flue length (mm)
Standard pack B + 90° Elbow	201816 201182	Right } Left } 775 Rear }
Standard pack B + 90° Elbow + 2 x Extension pack D (HE 30/36)	201816 201182 2 x 201180	Right } Left } 2585* Rear }
Standard pack B + 90° Elbow + 5 x Extension pack D (HE 30/36)	201816 201182 5 x 201180	Right } Left } 5000* Rear }

*Maximum HE 30 & 36 length is 2000mm

Note: Where extension D packs are cut to length, flared end connector must be retained.

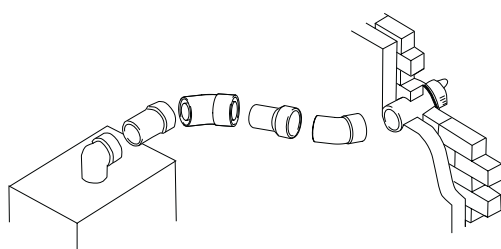

HORIZONTAL FLUE WITH 2 x 45° ELBOW

Flue	Part Number	Maximum straight flue length (mm)
Standard pack B + 2 x 45° Elbow	201816 201183	Right } Left } 775 Rear }
Standard pack B + 2 x 45° Elbow + 2 x Extension pack D (HE 30/36)	201816 201183 2 x 201180	Right } Left } 2085* Rear }
Standard pack B + 2 x 45° Elbow + 5 x Extension pack D (HE 15-24)	201816 201183 5 x 201180	Right } Left } 4500 Rear }

*Maximum HE 30 & 36 length is 1500mm

Note: Where extension D packs are cut to length, flared end connector must be retained.

VERTICAL EXTENSION

Permits horizontal flue section to be raised to clear restrictions.

Flue	Part Number	Maximum straight flue length (mm)
Standard pack B	201816	} 7000 (15-24) 4000 (30-36)
+ Vertical outlet kit	201871	
+ Appropriate Extension packs	201180	

Note: Maximum flue length is combined horizontal and vertical.

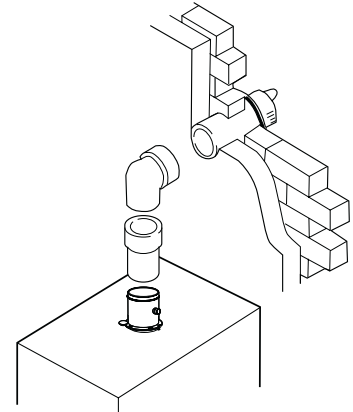

Vertical concentric - 100mm diameter

Maximum flue length for HE 15 / 18 / 24 models is 8 metres.

Maximum flue length for HE 30 / 36 models is 5 metres.

ROOF FLUE SYSTEM

Flue	Part Number	Maximum straight flue length (mm)
Roof flue kit	201189	} 1000
+ Vertical connector	201869	
+ Weather collar	158431 / 158432*	
Roof flue kit	201189	} 8000 (HE 15/18/24) 5000 (HE 30/36)
+ Vertical connector	201169	
+ Weather collar	158431 / 158432*	
+ 7 (maximum) x Extension packs - (15-24)	201180 (x7)	
+ 4 (max.) x Extension packs - (30-36)	201180 (x4)	

Note: 158431: universal weather collar (suits any roof pitch).

*158432: flat roof weather collar.

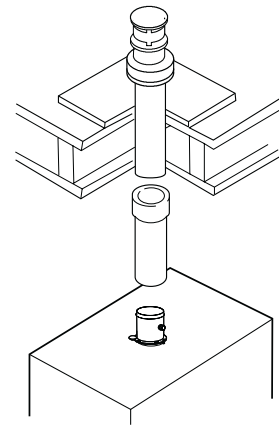

ROOF FLUE SYSTEM WITH 2 x 45° ELBOW

Flue	Part Number	Maximum straight flue length (mm)
Roof flue kit	201189	} 6500 (HE 15/18/24) 3500 (HE 30/36)
+ Weather collar	158431 / 158432*	
+ Vertical connector	201869	
+ 2 x 45° Elbow	201183	
+ 6 (max.) x Extension packs - (15-24)	201180 (x 6)	
+ 3 (max.) x Extension packs - (30-36)	201180 (x 3)	

Note: 158431: universal weather collar (suits any roof pitch).

*158432: flat roof weather collar.

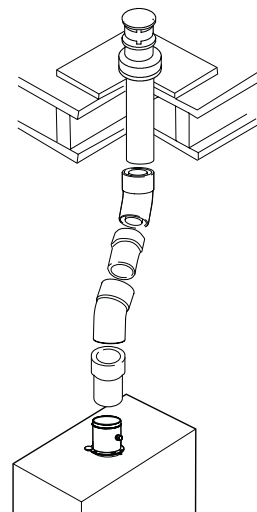

extras and accessories

There are many extras and accessories available for use with the classic HE & mexico HE ranges. All are competitively priced and readily available.

Flue pack D (Extension kits)

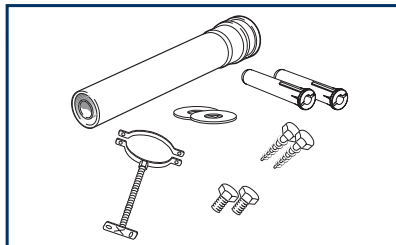

Cuttable. 100mm diameter x 950mm extension, including flue and air seals, clamp, support bracket and fixings. Ideal Part No. 201180.

Flue finishing kit

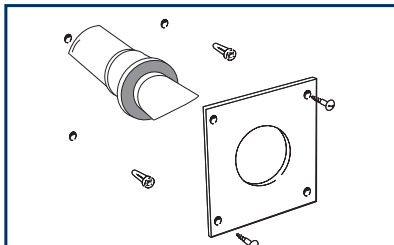

For 100mm diameter terminal. Includes internal wall seal and external wall seals, wall plate (brown) and fixings. Ideal Part No. 201181.

90° Elbow kit

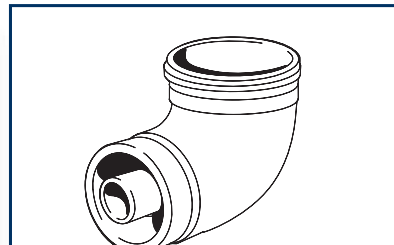

Painted white. Includes flue and air seals. 100mm Ideal Part No.201182.

45° Elbow kit

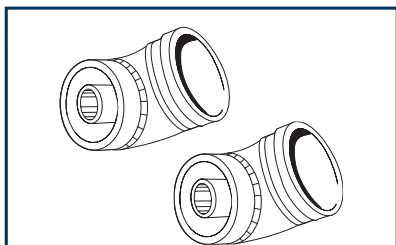

Painted white. Includes flue and air seals x 2 per carton. 100mm Ideal Part No. 201183.

Vertical flue connector - classic HE only

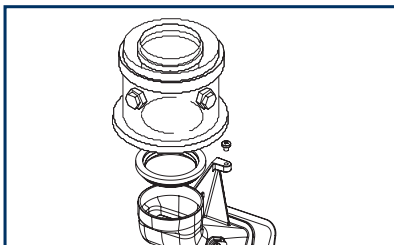

Comprises, vertical connector and top outlet casting. Ideal Part No. 201867

Side outlet kit - classic HE only

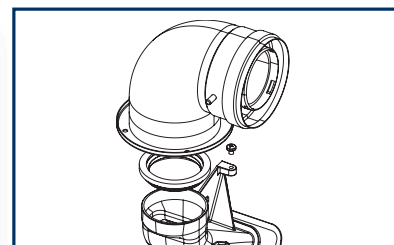

Comprises turret elbow and top outlet casting. Ideal Part No. 201866.



classic HE



mexico HE

Roof flue kit

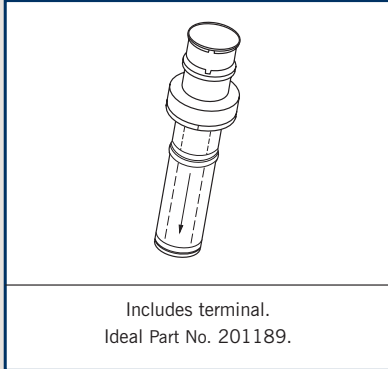

Weather collar – flat roof

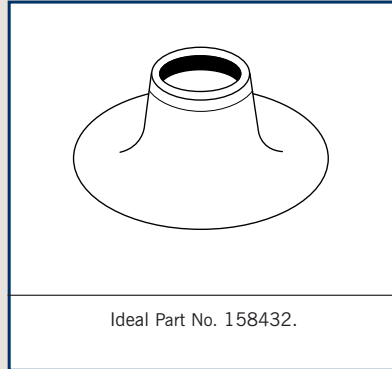

Weather collar - universal

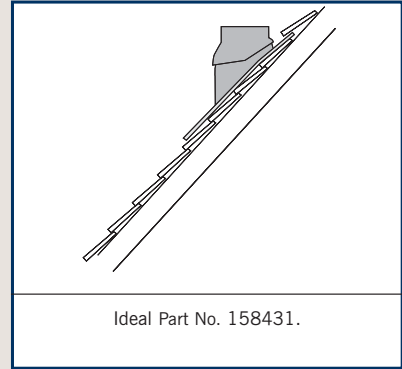

Downward piping kit - classic HE

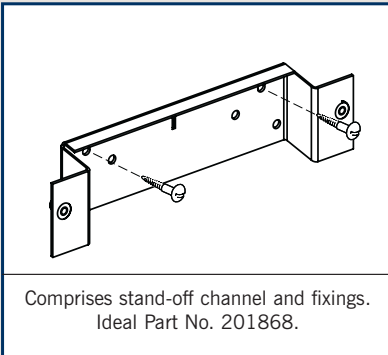

Vertical flue connector - mexico HE

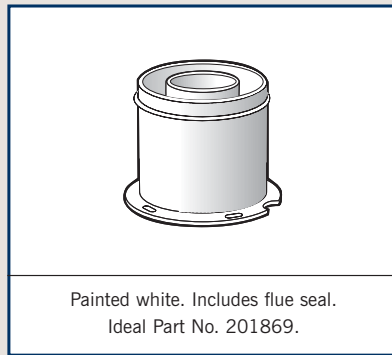

Vertical outlet kit - mexico HE

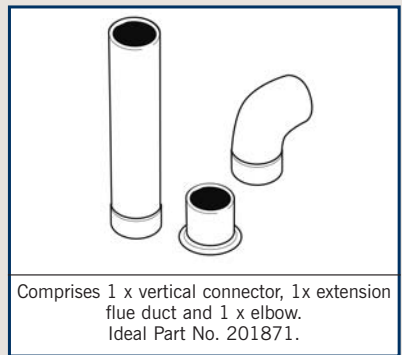

Remote user control kit - mexico HE

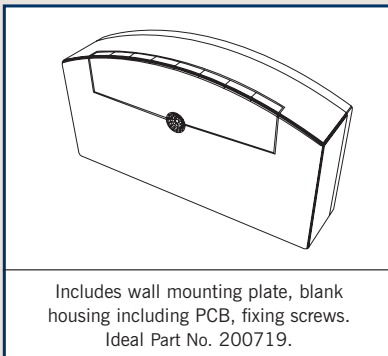

Concealment panel kit - mexico HE

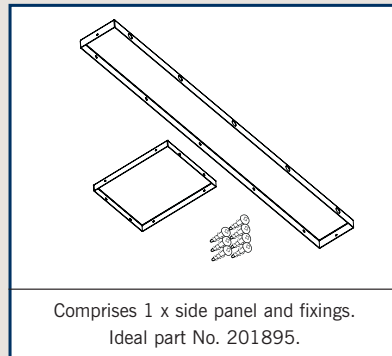

Terminal wall plate kit - mexico HE

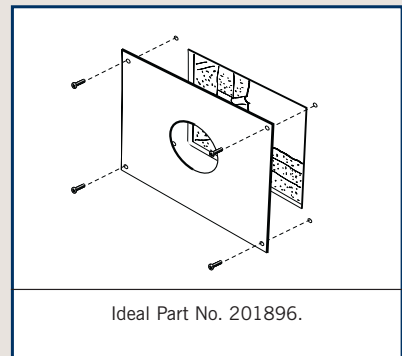

Condensate pump kit

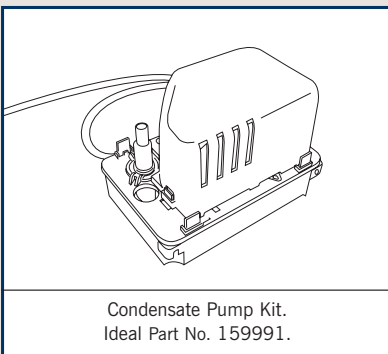

imax W range



Customers increasingly demand higher efficiencies and lower emissions from the heating plant. All this must be achieved in ever smaller dimensions. For systems requiring larger outputs, the imax W range provides the solution. A straightforward wall hung HE boiler like its smaller stablemates, the imax is easy to install and commission

imax W

The Ideal imax W wall mounted boiler comes in a range of outputs 45, 60 or 80kW and all are capable of being installed as a single unit or in simple modular formations for even bigger outputs. The imax W is a highly efficient fully condensing boiler - up to 98% efficient nett (88.5% gross) non condensing and an impressive 108% nett (97.3% gross cv) at 30% load, fully condensing.

- Natural gas and propane
- High operating efficiencies with close load matching
- Wide modulating output range from 13 to 80kW
- Robust cast aluminium heat exchanger
- Integral commissioning and fault diagnostics
- Flue flexibility, concentric and twin duct, room sealed or open flue applications
- Easy to install and service
- Comprehensive control options
- Single unit or modular configuration, wall or frame mounted

PERFORMANCE DATA

Model		W45 & W45P	W60 & W60P	W80 & W80P
Output	kW	12.6 - 43.7	12.6 - 58.9	19.5 - 78.2
	Btu/h	43,000 - 149,000	43,000 - 201,000	66,500 - 267,000
SEDBUK rating		A	A	A
NOX Class		5	5	5

INSTALLATION DATA

Model		W45 & W45P	W60 & W60P	W80 & W80P
Flow connection	BSP		R1¼"	
Return connection	BSP		R1¼"	
Maximum static water head	m		40.79	
	ft		133.83	
Maximum pressure	Bar		4.0	
	psi		58	
Gas inlet connection	mm		22	
Pressure required at the boiler inlet for the rated input (Natural Gas)	mbar		17.5	
	in. w.g.		7.0	
Electricity supply			230V 50Hz	
Nominal flue size / concentric	mm	80 / 125	80 / 125	100 / 150
Nominal flue size / twin-pipe	mm	80 / 80	80 / 80	100 / 100
Condensate drain	mm		25	
Water content	l	8	8	10
	gal	1.76	1.76	2.20
Weight	kg	87	88	101
	lb	191	194	222
Power consumption	W	51	84	120

Flue kits

The flue kits are suitable for use with the Ideal imax boiler only. These kits and the associated options are suitable for both roof and wall mounting applications.

Several flue options are available:

- Horizontal flue kits (80/125 mm or 100/150 mm diameter)
- Vertical roof flue kits (80/125 mm or 100/150 mm diameter)
- Twin-pipe flue kits
- Open flue kits

The twin-pipe flue kit is suitable where particularly long flue runs are required and compact flue and air ducts are required.

The roof kit is suitable for both flat and pitched roof termination, using a concentric flue (tube within tube) to run vertically from the top of the boiler and terminating above the roof level.

The maximum potential length for each type of boiler model is shown in the table below, although allowances must be made when elbows are used.

Maximum lengths (metres)	W45	W60	W80
Horizontal wall flue kit 80/125	9.5	7.8	-
Horizontal wall flue kit 100/150	31.6	26	16
Vertical roof flue kit 80/125	9.6	7.8	-
Vertical roof flue kit 100/150	31.6	26	16
Twin-pipe flue kit (W45 & W60 only*)	29	19	-
Open flue kit 80	20	13.3	-
Open flue kit 100	-	-	29

* Maximum combined air and flue ducts

CLEARANCE DATA

The following clearances are required for installation, servicing and replacement of parts.

Front of boiler	Sides of boiler	Above of boiler	Below boiler
450 mm	50 mm	dependent upon the flue system	300 mm

Note: this appliance is not suitable for external installation. The wall on which the boiler is being mounted must be able to support its total weight. The wall will not require special protection, but if the unit is being fitted in a timber-frame building the guidelines set out in BS 5440: Part 1:1990 should be observed.

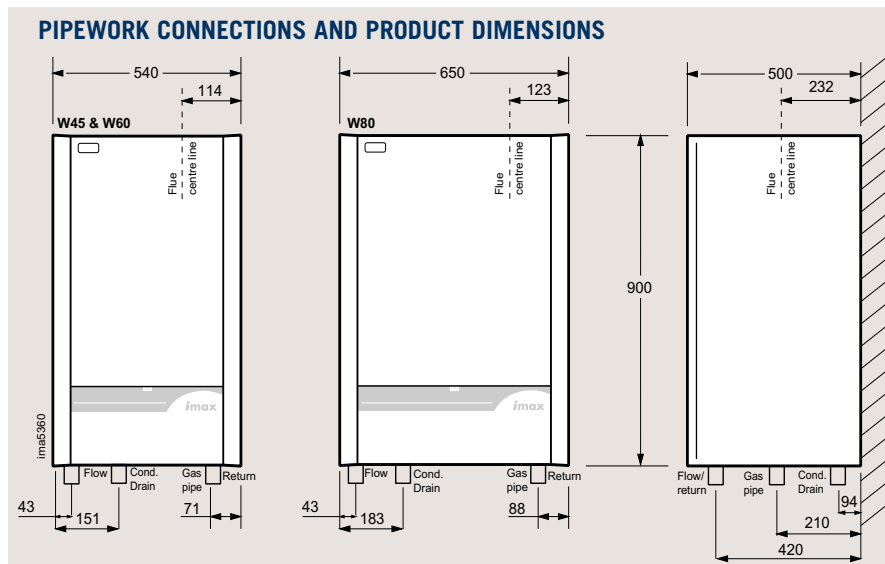

For full technical details please refer to the Installation and Servicing Instructions provided with the product.

The Ideal high-efficiency imax boiler

Installation tips

The boiler has a cast aluminium alloy heat exchanger, therefore suitable water treatment should be applied to the system. These boilers require a permanent live electrical supply. Boiler frost protection is built in to the appliance.

Siting options

Compact dimensions for high outputs and a highly flexible fluing system allow the imax to be easily sited.

Accessories

- Flue duct extensions.
- Elbows, 90° and 45°.
- Flat and pitched roof weather collars.

Controls kits

A range of kits including an outside sensor kit is available.

SEDBUK rating



This product has an energy rating of A on a scale of A-G. For more information see www.sedbuk.com

FLUE OPTIONS

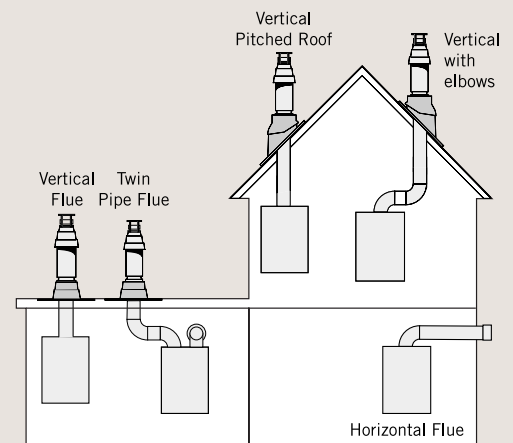

support

technical helpline

01482 498663

or alternatively fax us on 01482 498666

parts orderline

01482 498665

literature hotline

0870 8498056

householder helpline

01482 498660

training

01482 498432

or alternatively fax us on 01482 498605

sales orders and enquiries

0870 8498056

or alternatively fax us on 0870 8498058

www.idealboilers.com

enquiries@idealboilers.com

Training

An absolute commitment to customer training places Ideal above its competitors. Acknowledged as industry experts in standard and high-efficiency products, Ideal's training staff offer both theoretical and 'hands-on' instruction in product and system applications to installers and merchants through training schools, colleges and mobile units.

After-sales

Ideal operates its own call centre and national network of engineers. Staff in the call centre are comprehensively trained to ensure that they provide technical solutions to the design, installation, service and maintenance of all Ideal products.

Dedicated Technical Helplines, one for installers (01482 498663) and one for householders (01482 498660) ensure that the caller is greeted by a member of staff specifically trained to meet their needs.

The Customer Service Helplines operate at the following times:

Monday - Friday 8 am - 5 pm

Saturday 8 am - 2 pm

Sunday 8 am - 12 pm

Service engineers

Ideal engineers only work on Ideal products. This together with ongoing training, a fully equipped van and the latest technological aids, underpin Ideal's first time fix capability.

Spares

Guaranteed spare parts for all appliances are generally available for a minimum of 10 years after cessation of production. Parts can be easily sourced from Ideal's nationwide network of approved stockists.

For information about Ideal spare parts and for a list of stockists please call our Parts Department on 01482 498665. Alternatively you can learn about Ideal products and its Parts listings through the website or the Ideal Parts CD available through the Parts Department.

Ideal HE combination and system storage boilers

For more information on Ideal's extensive range of combination and system storage boilers, see our High-Efficiency Combination Boiler brochure.

isar high-efficiency combination boiler

The Ideal isar HE high-efficiency combination boiler shares the same benefits as its icos HE heat-only counterpart but has all the necessary components incorporated into the product to enable easy installation to a fully pumped sealed system and delivers mains pressure hot water.

The boiler is ideal for meeting the heating requirements for the majority of houses and is available in three models, isar HE 24, isar HE 30, and isar HE 35.

SEDBUK rating



istor high-efficiency boiler

A complete heating and unvented hot water system in a single unit gives a simple and space saving installation. The Ideal istor HE high-efficiency boiler ensures low running costs in conjunction with a fast recovery cylinder for large quantities of mains pressure hot water. The istor HE is available in two models, the istor HE 260 and the istor HE 325.

SEDBUK rating



excel high-efficiency combination boiler

The Ideal excel HE high-efficiency combination boiler is a straightforward design based on familiar technology, offering easy installation and servicing. A range of 3 models, 24, 28 and 32kW ensures there is a product for every situation.

SEDBUK rating



mini HE high-efficiency combination boiler

Simple and robust designs using familiar technology providing easy installation and servicing. A choice of two combination boilers.

SEDBUK rating

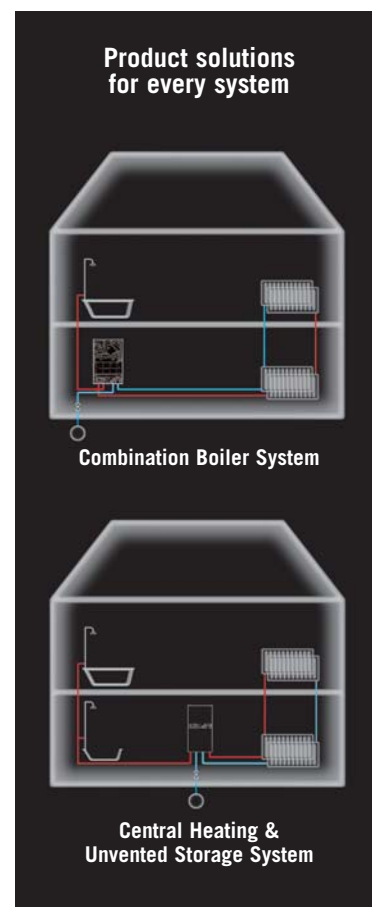

Ideal Boilers is a member of the Benchmark Initiative and fully supports the aims of the programme. Benchmark has been introduced to improve standards of installation and commissioning of central heating systems in the UK and to encourage the regular servicing of all central heating systems to ensure safety and efficiency.

BS EN ISO 9001:2000

Ideal Boilers, PO Box 103,
National Avenue,
Kingston upon Hull HU5 4JN.

Tel: 01482 492251

Fax: 01482 448858

www.idealboilers.com

email: enquiries@idealboilers.com



The code of practice for the installation,
commissioning & servicing of central heating systems

i Ideal BOILERS
The High Efficiency Pioneers

100
YEARS OF
Engineering
Excellence

Ideal Boilers and
Stelrad Radiators
1905-2005