



Full Depth Convector RC

COAL EFFECT GAS FIRE

Installation and Maintenance Instructions

Hand these instructions to the user

Model No's MICCRN is for use on Natural Gas (G20) at a supply pressure of 20mbar in G.B. / I.E.**

CONTENTS

Section 1	Information and Requirements	PAGE
1.0	Appliance Information	3
1.1	Manual Handling Advice	4
1.2	Conditions of Installation	5
1.3	Flue and chimney suitability	5
1.4	Fireplace / surround suitability	6
1.5	Shelf position	6
1.6	Chimney inspection	7
1.7	Fire place opening / catchment space	8
1.8	Fitting to Metal Flue Boxes	10
1.9	Hearths	10
1.10	Spillage Monitoring System	10
1.11	Clearances to Combustible & Non-Combustible Surfaces	10
Section 2 Installation of Fire		
2.1	Unpacking the fire	11
2.2	Installing the fire box	11-16
2.3	Gas tightness and burner pressure	17
Section 3 Assembling Fuel Bed and Commissioning		
3.1	Assembling the ceramics and fuel bed	18-21
3.2	Fixing the Infrared Eye in Position	22
3.2	Lighting the appliance	23
3.3	Checking for clearance of combustion products	24
Section 4 Maintenance		
4.1	Removal of the Burner Assembly (Manual)	25
4.2	Removal of the Solenoid	26
4.3	Removal of the Pilot assembly	26
4.4	Removal of the batteries	26

The model no. of this appliance is as stated on the rating plate.

This product has been manufactured by :

CFM Europe Ltd,
Trentham Lakes,
Stoke-on-Trent,
ST4 4TJ

SECTION 1 INFORMATION AND REQUIREMENTS

1.0 APPLIANCE INFORMATION

Model	MICC**RN
Gas Type	G20
Main injectors (2 off)	Size 260
Pilot Type	Copreci
	21100 / 162
Max. Gross Heat Input :	6.9 kW
Min. Gross Heat Input :	4.2 kW
Cold Pressure :	20.0 +/-1.0 mbar
Ignition :	6V Battery Generator
Electrode Spark Gap :	4.5 Nominal
Weight :	20 kg
Minimum Combustible Shelf Height above fire	200mm (from top of fire)

Fire box Dimensions (with trim fitted see fig. 1 below)

Width :	(with standard trim)	485mm
Height :	(with standard trim, no spacer)	595mm
Depth :	(Into room)	75mm
Depth :	(from mounting face to rear)	246mm (with baffle)
Depth :	(from mounting face to rear)	227mm (without baffle)
Gas Connection	8mm Compression	(Supplied with fire)

Fig. 1

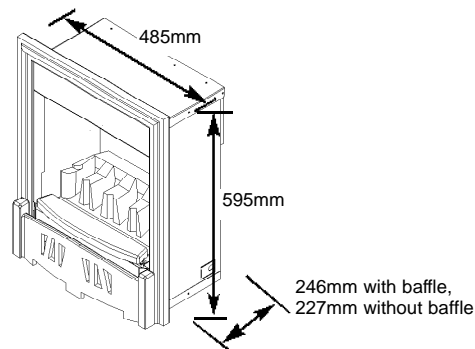

1.1 MANUAL HANDLING ADVICE

The following advice is offered when moving, manipulating and installing this product :-

Always keep your back straight - bend using your legs

Avoid twisting at your waist - reposition your feet instead

Avoid upper body and top heavy bending - do not lean forwards or sideways

Always grip the product with the palms of your hand - not the tips of your fingers

Use the hand holes in the packaging that are provided

When lifting the product keep the load as close to your body as possible (minimise the cantilever action and use your clothing to provide additional grip)

Always use assistance if required

IF IN DOUBT REGARDING ANY MANUAL HANDLING OF THIS PRODUCT - ASK !

INSTALLATION REQUIREMENTS

1.2 CONDITIONS OF INSTALLATION

In Great Britain :-

It is the law that all gas appliances are installed only by a CORGI Registered Installer in G.B. in accordance with these installation instructions and the Gas Safety (Installation and Use) Regulations (current edition). Failure to install appliances correctly could lead to prosecution. It is in your own interest and that of safety to comply with the law. The installation must also be in accordance with all relevant parts of the Local and National Building Regulations where appropriate, the Building Regulations (Scotland Consolidation) issued by the Scottish Development Department, and all applicable requirements of the following British Standard Code of Practice.

1. B.S. 5871 Part 3 Installation of Decorative Fuel Effect Gas Fires
2. B.S. 6891 Installation of Gas Pipework
3. B.S. 5440 Parts 1 & 2 Installation of Flues and Ventilation
4. B.S. 1251 Open fire place components
5. B.S. 715 Metal flue pipes for gas appliances
6. B.S. 6461 Part 1 Installation of Chimneys and flues
7. I.S. 813 : 1996 Domestic Gas Installation (Republic of Ireland)

In Republic of Ireland :-

No purpose made additional ventilation is normally required for this appliance, when installed in G.B. When installing in I.E. please consult document I.S. 813 : 1996 Domestic Gas Installation, which is issued by the National Standards Authority of Ireland. If installing in Northern Ireland, please consult local building regulations. Any purpose made ventilation must be checked periodically to ensure that it is free from obstruction.

1.3 FLUE AND CHIMNEY SUITABILITY

This appliance is designed for use with conventional brick built or lined chimneys and fabricated flues and metal flue boxes conforming to BS 715. All flues must conform to the following minimum dimensions.

- 225mm x 225mm brick built chimneys (9 inch x 9 inch)
- 175mm (7 inch) diameter lined brick or stone flue, or insulated, pre fabricated metal flue box to B.S. 715
- 125mm (5 inch) diameter lined brick or stone flue, or insulated, pre fabricated metal flue box to B.S. 715

Before fitting to any flue of less than 175mm diameter or equivalent cross-sectional area, the spigot restrictor baffle on the rear of the fire must be removed

Safe clearance of products must always be checked by carrying out a smoke match test as described. (see fig. 19 on page 23)

1.4 FIREPLACE / SURROUND SUITABILITY

The fire must only be installed on a hearth it **must not be installed directly onto carpet or other combustible floor materials**. The fire is suitable for fitting to non-combustible fire place surrounds and proprietary fire place surrounds with a temperature rating of at least 150°C.

If a heating appliance is fitted directly against a wall without the use of a fire surround or fire place all combustible material must be removed from behind the trim. Soft wall coverings such as blown vinyl, wall paper etc. could be affected by the rising hot air and scorching and/or discoloration may result. Due consideration should be made to this when installing or decorating.

1.5 SHELF POSITION

The fire may be fitted below a combustible shelf providing there is a minimum distance of 200mm above the top of the fire and the shelf does not project more than 150mm. If the shelf overhangs more than 150mm the distance between the fire and the shelf must be increased by 15mm for every 25mm of additional overhang over 150mm. See shelf graph (fig. 2 below)

Fig. 2

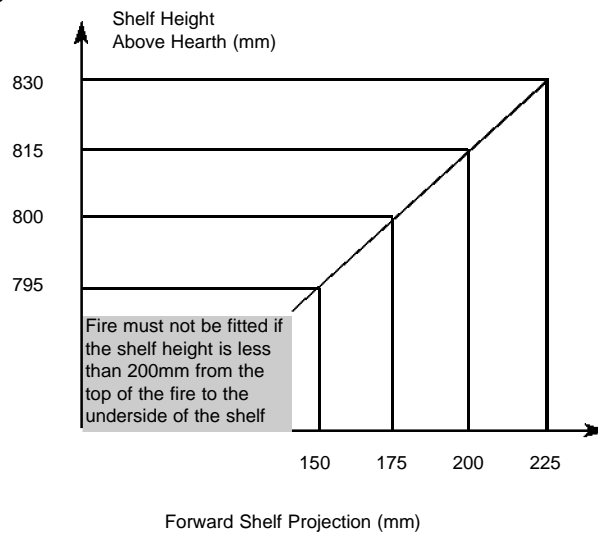

1.6 FLUE / CHIMNEY INSPECTION

Before commencing installation, a flue or chimney should be inspected to ensure that all the following conditions are satisfied.

1. Check that the chimney / flue only serves one fire place and is clear of any obstruction. Any dampers or register plates must be removed or locked in the open position.
2. Brick/stone built chimneys or any chimney or flue which has been used for an appliance burning fuel other than gas must be thoroughly swept. The base of the chimney / flue must also be thoroughly cleared of debris etc.
3. Any under-floor air supply to the fire place must be completely sealed off.
4. Ensure that the inside of the chimney / flue is in good condition along it's length and check that there is no leakage of smoke through the structure of the chimney during and after the smoke pellet test. **With pre-cast flues it is especially important to check the inside of the flue for extruded cement / sealant protruding from the joints between the flue blocks. If present, these should be removed by rodding the flue before proceeding with the installation.**
5. **Using a smoke pellet, check that there is an up-draught in the chimney / flue and that the smoke can be seen issuing from the terminal / chimney pot outside. There must be no leakage of smoke through the structure of the chimney during or after the smoke pellet test and it is important to check inside upstairs rooms adjacent to the chimney / flue.** Check the chimney pot / terminal and general condition of the brickwork or masonry. If the chimney or flue is in poor condition or if there is no up-draught do not proceed with the installation. If there is a history of down-draught conditions with the chimney / flue, a tested and certificated flue terminal or cowl suitable for the relevant flue type should be considered.
6. **A spillage test must always be carried out during commissioning of the appliance. (see fig. 21 on page 25)**

BEFORE FITTING THIS APPLIANCE TO A CLASS 2 (125mm DIAMETER) FLUE, THE SPIGOT RESTRICTOR BAFFLE MUST BE REMOVED.

1.7 FIRE PLACE OPENING AND CHIMNEY CATCHMENT SPACE

The front opening of the fire place must be between 400 and 450 mm wide, and between 550 and 570mm high.

Any chairbrick that is in place must be removed before proceeding with the installation of this appliance.

If the opening exceeds these dimensions then a surround must be constructed from suitable non-combustible material to produce a correct size opening.

Any surround must be suitably sealed to the fire place to prevent leakage. See below in fig. 3

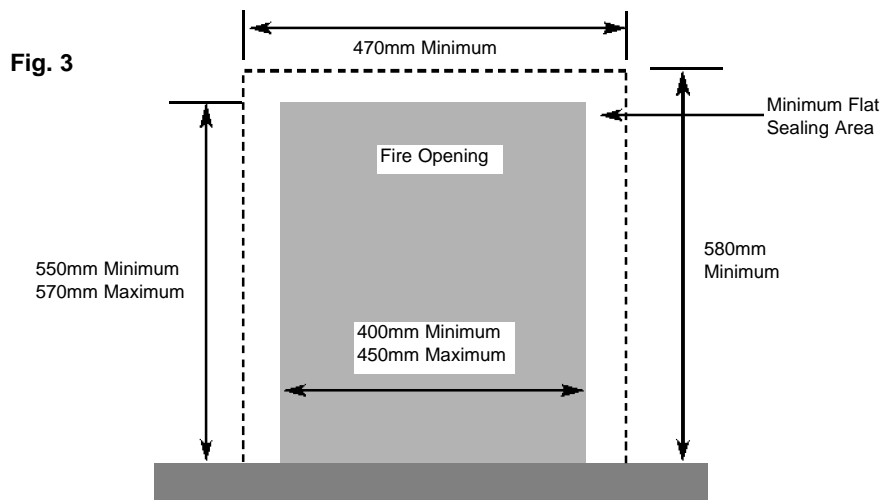

When installing into a brick built chimney, you must ensure that there is sufficient depth to accommodate any debris which may fall from the chimney. This depth must be sufficient to accommodate 12 litres of volumetric space.

Table A - Installation Depth Requirements for a Mesina Full Depth Convector being installed into a brick built chimney, requiring 12.0 litres of debris collection volume (fig. 2)

Opening Width (mm)	Minimum Depth Required (mm)
400 (minimum opening width)	298
410	292
420	285
430	280
440	273
450 (maximum opening width)	269

For example, if the appliance was to be fitted into a 400mm wide opening, the depth required would be 298mm. See fig. 4 below for explanatory diagram.

Fig. 4

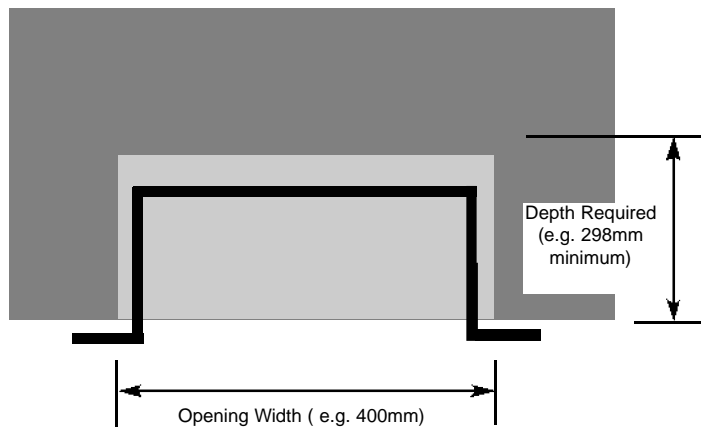

1.8 FITTING TO PRE-FABRICATED TWIN WALL METAL FLUE BOXES

The appliance may be fitted to twin wall metal flue boxes conforming to the constructional requirements of BS 715, (for example the Selkirk LFE 175 box). The box must have a minimum flue diameter of 175mm internal and minimum internal dimensions of 300mm deep by 580mm high by 400mm wide. There are no maximum dimensional requirements for the box. The top face of the box must be insulated with a minimum thickness of 50mm of non-combustible mineral wool insulation or similar material. The flue box must stand on a non-combustible base of minimum thickness 12mm.

1.9 HEARTHES

This appliance must only be installed on to a concrete or non-combustible hearth. The hearth material must be a minimum thickness of 13mm with the top surface at least 50mm above the floor. The hearth must be fitted symmetrically about the fire opening and have a minimum width of 760mm and a minimum projection of 300mm forwards from the fire opening. If the appliance is fitted with an optional black 50mm spacer frame, then the hearth projection must be increased to 350mm forwards of the fireplace opening.

1.10 SPILLAGE MONITORING SYSTEM

This appliance is fitted with an atmosphere sensing spillage monitoring system in the form of an oxygen sensing pilot. This is designed to shut the fire off in the event of a partial or complete blockage of the flue causing a build up of combustion products in the room in which the fire is operated. **The following are important warnings relating to this spillage monitoring system :-**

- 1) The spillage monitoring system must not be adjusted by the installer.
- 2) The spillage monitoring system must not be put out of operation.
- 3) When the spillage monitoring system is exchanged only a complete original manufacturers part may be fitted. It is not possible to replace individual parts on the pilot system on this appliance, only a complete pilot assembly (including the thermocouple) may be fitted.

1.11 CLEARANCES TO COMBUSTIBLE & NON-COMBUSTIBLE SURFACES

This appliance may be installed into a combustible fire surround, providing that the following clearances are available :-

Combustible Side Clearance	175mm minimum
Clearance to Combustible Shelf	200mm minimum, see shelf graph on page 5 for further information.
Non-Combustible Side Clearance	30mm minimum
Clearance to Combustible Shelf	200mm minimum, see shelf graph on page 5 for further information.

SECTION 2 INSTALLATION OF FIRE

2.1 UNPACKING THE FIRE

Carefully lift the fire out of the carton. Remove the loose item packaging carefully from the front of the appliance. Check the contents as listed :-

Packing Check List

1off	Fire box / burner assembly
1off	Boxed ceramic base, front ceramic rail and 20 coals (18 large, 2 small)
1off	Loose items bag.
1off	Fret & ashpan (Boxed)
1off each	User instruction book and Installation book

2.2 INSTALLING THE FIRE BOX

Establish which type of flue you are intending to install the fire in to :-

**225 x 225mm (9 inch x 9 inch) brick built chimneys
175mm (7 inch) diameter lined brick or stone flue, insulated pre-fabricated metal flue box to B.S. 715.**

When installing into 125mm (5 inch) diameter lined brick or stone flue, or insulated pre-fabricated metal flue box to B.S. 715 the restrictor baffle must not be fitted.

A spillage test must always be carried out to check satisfactory clearance of flue products, regardless of the type of flue the appliance is being fitted to. (see fig. 19 on page 23)

Proceed as follows :-

- a) Remove the trim / fret. Remove the burner heat shield from the front of the fire box to allow access to the burner. See fig. 5 below.

Fig. 5

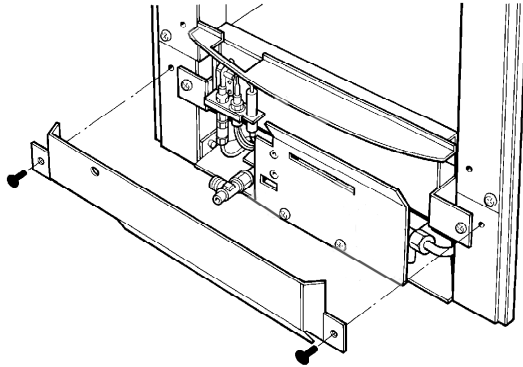

- b) Ensure that the hearth is protected from damage and carefully lift the fire box into the fire opening, then slide it back into position. Check that the fire box flange fits flush to the sealing face of the fire surround or wall with no gaps present.
- c) Remove the four retaining screws securing the burner to the firebox. The base of the burner unit can now be pulled forward, allowing the burner to be removed outwards and downwards from the fire box. Take care not to pull wires connected to the PCB assembly See fig. 6 below.

Fig. 6

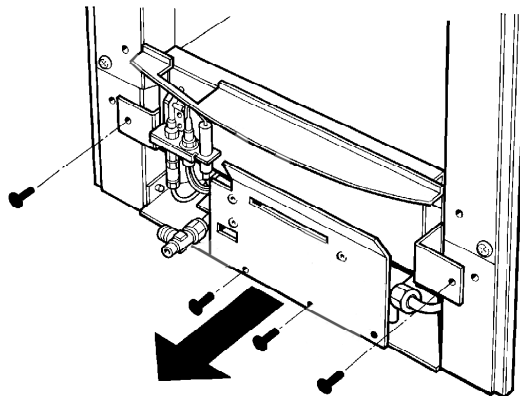

Carefully remove the HT lead from the pilot assembly.

Continue for all models

Whilst the fire box is still in position, decide which side the gas supply is to enter the fire from. If concealed pipe work is required plan the pipe run to enter the fire box through one of the openings in the sides of the fire box below the fuelbed support panel and connect to the isolating / inlet elbow. The gas connection to the appliance should be made to the isolating / inlet elbow using 8mm rigid tubing. There must be no soldered joints within the firebox. See fig. 7 & 8 below for suggested concealed pipe layouts.

Fig. 7

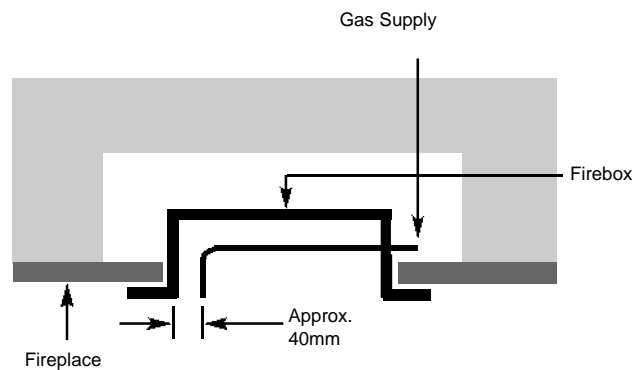
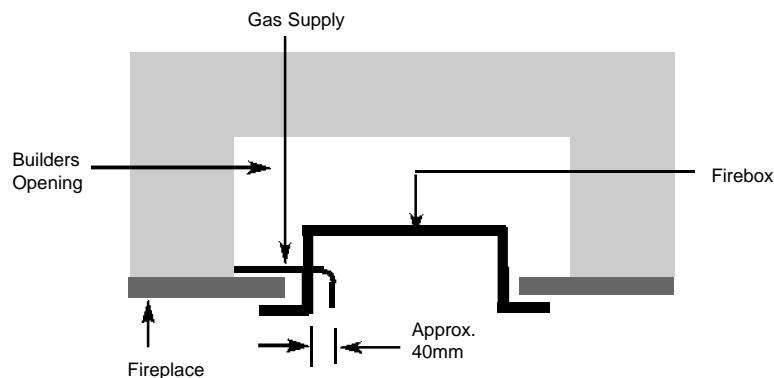

Fig. 8



Note : Before breaking into the gas supply a pressure drop test should be carried out to establish that the existing pipework is sound.

Carefully withdraw the fire box from the opening to enable the gas supply and fire fixing to be completed.

The preferred method of fixing which is suitable for almost all situations is the cable fixing method which is described in the following section in detail.

If the 2 inch black spacer is used, the fire may be secured using the cable method as described below, or alternatively, in installations where the cable method is not suitable (eg. loose masonry in rear of fire opening) the spacer may be removed from the fire box and secured to the fire surround using protruding screws which engage on to the key hole slots on the rear face of the spacer. The spacer will then need to be sealed to the fire surround. The fire box can then be refitted to the spacer.

To fit using the **preferred** cable method proceed as follows-

- h) Mark out and drill 4 off No 14 (6mm) holes in the back face of the fire opening in the positions shown below in fig. 9

Fig. 9

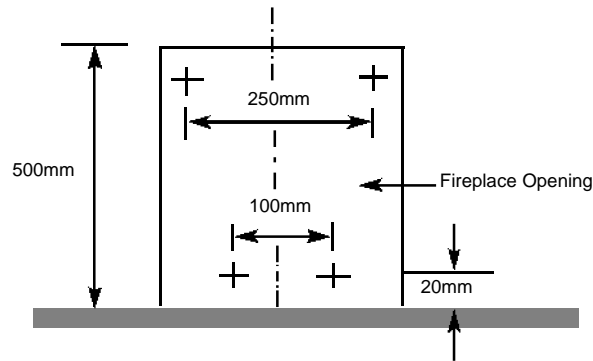

Fit the wallplugs provided and screw the fixing eyes securely into the rear of the fire opening. If the clearance at the rear of the fire is at the minimum specified for a precast flue application, it may be necessary to bend over the lower fixing eyes after screwing them fully in to the rear of a pre-cast starter block.

- i) Uncoil the two fire fixing cables and thread one end of each of the cables through one of the two holes on each side of the flue outlet shroud.
- j) Position the fire carefully on the (protected) surface of the hearth and reach into the fire opening. Thread each of the cables vertically downwards through the pair of fixing eyes on the same side of the fire. Thread the free end of the cables through the corresponding circular hole on each side of the lower rear of the fire. Carefully slide the fire box back into the fire opening and pull both cables tight.

- k) Thread a tensioning screw over each of the cables and ensure that the tensioning nut is screwed fully up against the hexagon shoulder of the tensioning screw (this provides maximum travel for the tensioning nut).
- l) Fit a screwed nipple on to each of the cables and pull hand tight up against the tensioning screw, then secure each nipple with a flat bladed screwdriver. See fig. 10 below

Fig. 10

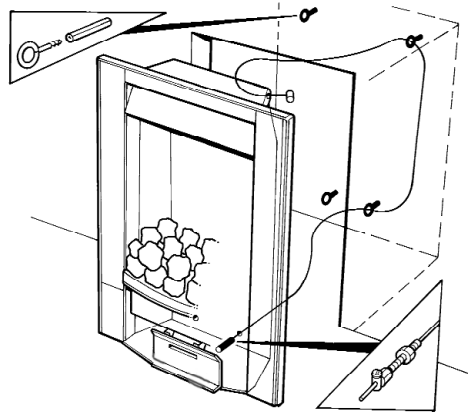

- m) Evenly tighten the tensioning nuts to tension both cables and pull the fire snugly against the wall. Do not overtighten, it is only necessary to pull the seal up against the sealing face of the wall, it does not need to be compressed. Check that there are no gaps behind the seal.
- n) With the fire securely in place, if a concealed gas connection has been made through either of the access holes in the sides of the fire, the holes should be closed around the pipe to prevent leakage of air through the gap around the pipe.
- o) Fit the four retaining screws and check that the burner is correctly locked into position.
- p) Refit the front burner heat shield to the sides of the fire box (2 Screws) and secure the trim to the fire using the magnets provided.
- q) **Before making the final gas connection, thoroughly purge the gas supply pipework to remove all foreign matter, otherwise serious damage may be caused to the gas control valve on the fire.**

The other firebox fixing method is as follows :-

In installations where the cable method is not suitable (e.g. loose masonry in rear of fire opening) the firebox can be secured to the fire surround using four screws and wall plugs provided. Below (fig.11) is a diagram to indicate the hole centre positions available on the firebox to facilitate the screw fixing to the fireplace / surround.

Fig. 11

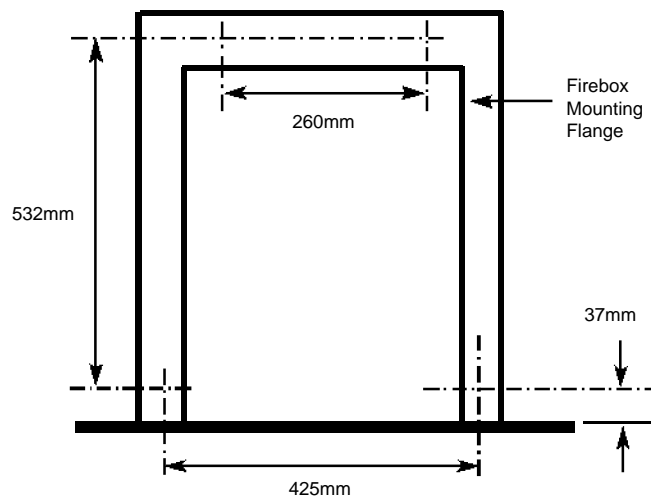

2.3 GAS TIGHTNESS AND BURNER PRESSURE

- a) Remove the pressure test point screw from the inlet elbow and fit a manometer.
- b) Turn on the main gas supply and carry out a gas tightness test.
- c) Depress both the round buttons on the handset. The fire will then commence its ignition sequence and will light to high. See page 22 for full details of the operating method for the fire.
- d) Check that the gas pressure is **20.0 mbar (+/- 1.0mbar) 8.0 in w.g.(+/- 0.4 in w.g.)**
- e) Turn off the fire, remove the manometer and refit the pressure test point screw. Check the pressure test point screw for gas tightness with the appliance turned on using a suitable leak detection fluid or detector.

SECTION 3 ASSEMBLING FUEL BED AND COMMISSIONING

The following ceramic components should be in the pack : 1 off fuelbed base, 1 off left hand ceramic front rail, 1 off right hand ceramic front rail, 18 large ceramic coals, 2 off small ceramic coals. The ceramic coals and fuelbed components are made from a form of refractory ceramic fibre and should be handled carefully to avoid generating dust, as this may be harmful if inhaled. As with some other fibrous materials, handling without gloves could cause skin irritation.

3.1 ASSEMBLING THE CERAMICS AND FUEL BED

- a) Place the ribbed ceramic fuelbed base on top of the fuelbed support and pull fully forwards to the burner. **Make sure that the fuelbed base is located centrally in the fire box. Ensure that the fuelbed base fit fully down onto the fuel bed support and is not lodged on the burner. See fig. 12 below.**

Fig. 12



- b) Position the two halves of the front ceramic pattern side up (L/H & R/H) on the locating channel in the front ceramic, ensuring it is located onto the lip on the burner front ceramic support. (See fig. 13 below)

Fig. 13



- c) Fit five of the large sized coals onto the front ceramic rail, ensuring that they are evenly spaced. Use the recess's in the front ceramic rail as a guide for placement. (See fig. 14 below)

Fig. 14

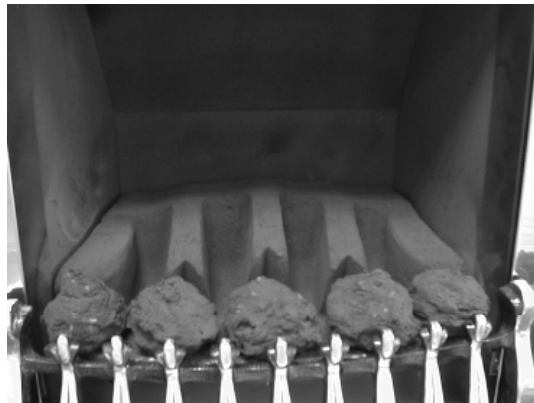

- d) Select four of the large coals and arrange behind the front row of coals, ensuring that flame paths as indicated below are not interrupted. Select two of the small coals and place at each end of the second row (See fig. 15 below)

Fig. 15

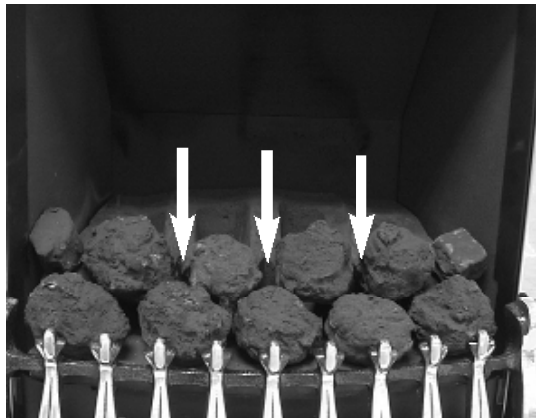

- e) Select five of the large coals and arrange along the rear of the fuelbed, using the ribs in the rear of the fuelbed as a guide for placement. (See fig. 16 below)

Fig. 16



- f) Select the four remaining large coals and position to fill the gaps at each end of the third row of coals, as shown. Fig. 17

Fig. 17



The exact position and fit of the coals may be finely adjusted to give the most pleasing and random appearance.

Warning : Use only the coals supplied with the fire. When replacing the coals remove the old coals and discard them. Fit a complete set of coals of the correct type. Do not fit additional coals or any coals other than a genuine replacement set.

This appliance uses fuel effect pieces containing Refractory Ceramic Fibres (R.C.F.), which are man-made vitreous silicate fibres. Excessive exposure to these materials may cause temporary irritation to eyes, skin and respiratory tract. Consequently, it makes sense to take care when handling these articles to ensure that the release of dust is kept to a minimum. To ensure that the release of fibres from these R.C.F. articles is kept to a minimum, during installation & servicing we recommend that you use a HEPA filtered vacuum to remove any dust and soot accumulated in and around the fire, before and after working on the fire. When replacing these articles we recommend that the replaced items are not broken up, but are sealed within a heavy duty polythene bag, clearly labelled as "RCF waste". This is not classified as "hazardous waste" and may be disposed of at a tipping site licensed for the disposal of industrial waste. Protective clothing is not required when handling these articles, but we do recommend you follow the normal hygiene rules of not smoking, eating or drinking in the work area, and always wash your hands before eating or drinking. This appliance does not contain any component manufactured from asbestos or asbestos related products.

3.2 FIXING THE INFRARED SENSOR IN POSITION

- a) Due to the large amount of different fascia's that can be supplied with these fires, the infrared sensor is supplied from the factory attached to a self adhesive pad. This pad can therefore be attached to the hearth in a position to suit the form of the fret or contemporary trim assembly that is chosen with the product. Fig. 18 below shows the self adhesive pad and infrared eye attached to the flying lead, as supplied from the factory.

Fig. 18

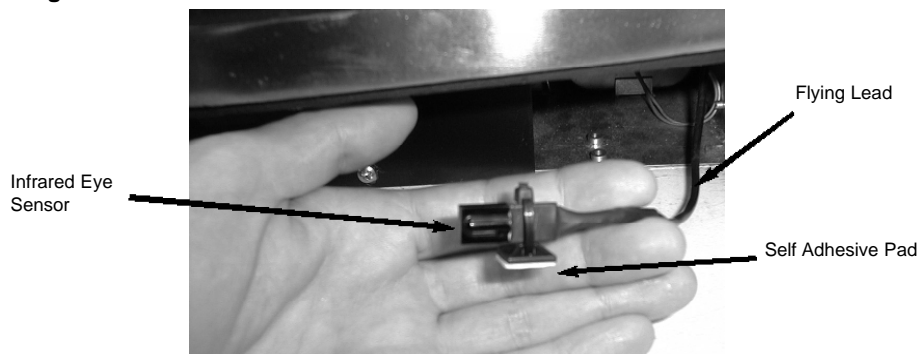

- b) Remove the backing paper from the self adhesive pad and position the infrared eye in the air channels in the ashpan cover, so that the infrared eye is flush with the front edge of the ashpan cover, as shown below in Fig. 19. Check the operation of the handset, as detailed in Section 3.3 and adjust the position of the infrared eye if necessary.

Fig. 19

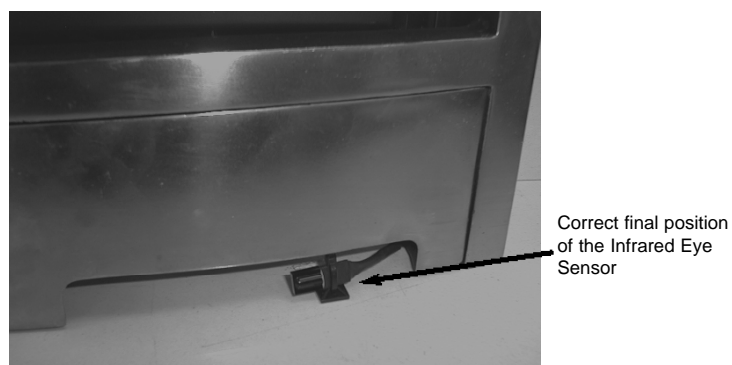

3.3 LIGHTING THE APPLIANCE

- a) The Remote control handset generates an infrared signal, which will be received by the sensor situated at the front right of your fire, behind the ashpan cover. This infrared signal requires direct line of sight from the handset to the sensor on the fire to ensure good operation. If the handset is lost or broken, the fire can be lit manually, see the user instructions for details on how to operate the fire manually.
- b) To light the appliance using the handset, ensure the switch on the control panel is set to automatic. Point the handset at the fire and press the 2 left hand buttons together. The fire will emit a “beep” sound, the buttons can now be released. After a few seconds an audible clicking can be heard and then the fire will light the pilot and then light the main burner. The ignition cycle will take approximately 20 seconds.
- c) To reduce the level of heat input on the fire, point the handset at the fire and press the small flame button. (See Fig. 20 below)
- d) To increase the level of heat input on the fire, point the handset at the fire and press the large flame button. (See Fig. 20 below)
- e) To leave the fire in the standby mode (pilot only running) press the small round button on the handset. (See Fig. 20 below)
- f) To switch the appliance off completely, press the large round button on the handset, the fire will then switch off. (See Fig. 20 below)

Fig. 20

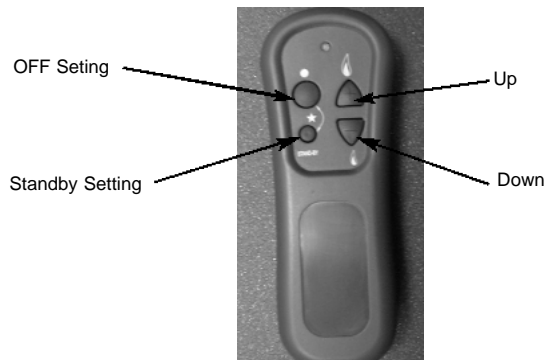

WARNING : If the fire goes out for any reason or is turned off and it is necessary to re-light the fire it is important to allow the fire to cool for 3 minutes before attempting to re-light it.

3.4 CHECKING FOR CLEARANCE OF COMBUSTION PRODUCTS

- a) Close all doors and windows in the room.
- b) Light the fire and allow to run for approximately 5 minutes on high position.
- c) After approximately 5 minutes hold a smoke match just inside and below the centre of the lower front edge of the top of the fire. See fig. 19 below (It is recommended that a suitable smoke match holder is used when checking for clearance of combustion products). All smoke generated should be drawn back into the flue. If slight spillage occurs or if in doubt, repeat the test after a further 5-10 minutes. **If the test indicates that spillage is occurring and the flue restrictor baffle has been fitted, it should be removed and the test repeated after the fire has cooled.**
- d) If spillage persists, the flue is not functioning correctly and a fault exists. If, after investigation the fault cannot be traced and rectified, the fire must be disconnected from the gas supply and expert advice obtained.
- e) If there is an extractor fan fitted anywhere in the vicinity of the appliance, the spillage test should be repeated with the fan running on maximum and all interconnecting doors open.
- f) After ensuring that the fire is safe to use it should be left on high position to fully warm up. During this time a slight odour may be noticed, this is due to the "newness" of the fire and will soon disappear. At this stage any minor adjustments to the coals should be made using suitable long handled tongs and taking care not to damage the coals. Finally, hand the Installation and Maintenance Instructions and the Users Instructions over to the customer and explain the operation of the fire.

Fig. 21

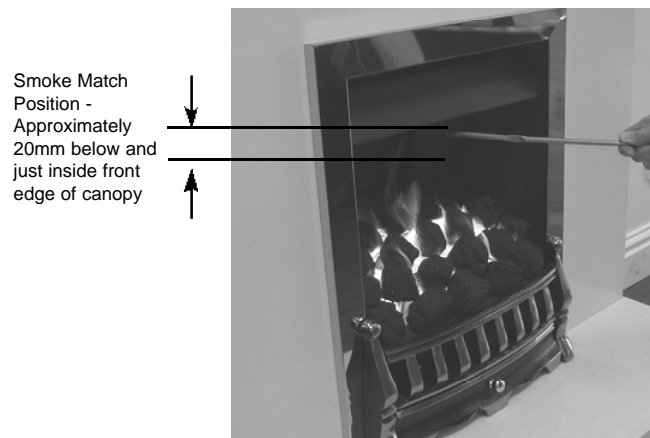

SECTION 4 MAINTENANCE

Servicing Notes

Servicing should be carried out annually by a competent person such as a CORGI registered engineer. The service should include visually checking the chimney and fire opening for accumulations of debris and a smoke test to check for a positive up-draught in the chimney.

The condition of the coals should be checked and **if necessary the whole set should be replaced with a genuine replacement set.**

The burner assembly is designed to be removed as a complete unit for ease of access. **After any servicing work a gas tightness check must always be carried out.**

For Diagrams refer to Section 2

4.1 Removing the burner assembly from the fire.

- 4.1.1 Prepare work area (lay down dust sheets etc.)
- 4.1.2 Lift the fender and ash pan cover out of the way and put them in a safe location. Remove the loose coals from the fuel bed and front ceramic rail. Remove the front ceramic from the rail. Unscrew the two pozi-driv fixing screws which secure the burner heat shield and remove it from the fire.
- 4.1.3 Isolate the gas supply and remove the inlet pipe from the appliance inlet elbow. Unscrew and remove the four screws which retain the burner. Remove the HT lead from the Pilot electrode and remove the burner assembly from the fire, ensuring not to pull too tightly on the PCB wiring.
- 4.1.4 To refit the burner assembly. Ensure wiring is fitted correctly to the PCB assembly. Push the base of the control panel fully into the fire and secure with the four screws. Refit the gas supply pipe and carry out a gas tightness test. Refit the burner heat shield then refit the coals referring to section 3 for the correct coal layout. The fender and ash pan cover can now be re-positioned.

4.2 Removing the Valve / Solenoid Assembly

- 4.2.1 Remove the burner assembly as in section 4.1
- 4.2.2 Remove the thermocouple retaining nut from the solenoid. remove the main pipe, inlet pipe and pilot pipe from the solenoid.
- 4.2.3 Remove the solenoid retaining screws and remove. Re-assemble in reverse order and carry out a gas tightness test.

4.3 Removing the Pilot Assembly.

Note : Because this appliance is fitted with an atmosphere sensing 'Oxy-Pilot' it is not possible to replace the thermocouple separately, because the thermocouple position is factory set to a tight tolerance. Any replacement of parts on the pilot requires a complete new pilot assembly.

- 4.3.1 Remove the burner assembly as in section 4.1.
- 4.3.2 Unscrew the thermocouple retaining nut from the solenoid.
- 4.3.3 Loosen the pilot nut and remove two screw retaining the pilot assembly.
- 4.3.4 Re-assemble in reverse order and carry out a gas tightness test.

4.4 Replacing the Batteries (Within the Firebox)

- 4.4.1 Remove the fender and ashpan assembly. The battery holder is located on the Right Hand side of the appliance .
- 4.4.2 Remove the battery pack with care and then disconnect the battery lead at the white rectangular plug and socket.
- 4.4.3 Replace in reverse order and check correct operation of the appliance.

NB The handset uses one LR61 (9v) and should be replaced by removing the cover on the rear of the handset.

**ENSURE THE BATTERIES ARE CONNECTED TO THE CORRECT POLARITY
POSITIVE (+), NEGATIVE (-)**

PARTS SHORTLIST

Replacement of parts must be carried out by a competent person such as a CORGI registered gas installer. The part numbers of the replaceable parts are as follows, these are available from your local stockist whose details are shown on the CFM Europe website, address shown below

Fuelbed base	B-58690
Fuelbed front rail	B-18730
Replacement coal set	B-58700
L/H Fibre Board	B-58610
R/H Fibre Board	B-58620
Upper Rear Fibre Board	B-58600
Lower Rear Fibre Board	B-58590

Due to our policy of continual improvement and development the exact accuracy of illustrations and descriptions contained in this book cannot be guaranteed

**Part No. B-85730
Issue 1**



CFM Europe Ltd
Trentham Lakes
Stoke-on-Trent
Staffordshire
ST4 4TJ

Telephone - General Enquiries : (01782) 339000
Telephone - Service / Repair : (08700) 101187