

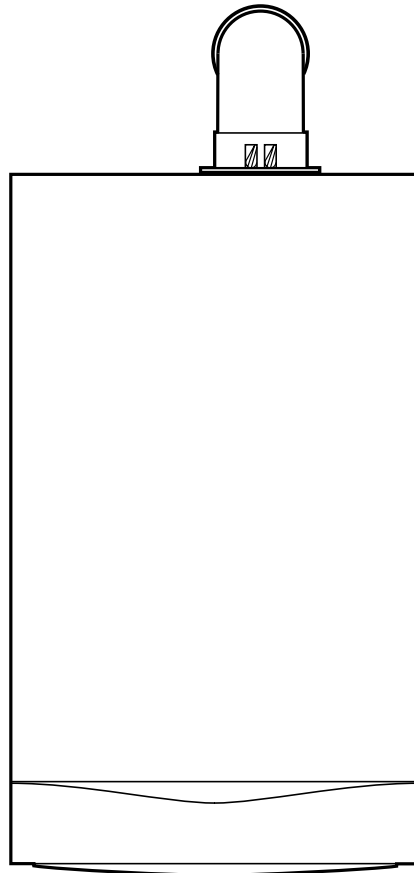

## Installation & Service Instructions

## Gold Combi HE Range



This is a Wall Mounted Powered Flue Condensing Combination Boiler Gas Fired Central Heating Unit.

The boiler meets the requirements of Statutory Instrument “ The Boiler (Efficiency) Regulations 1993 N° 3083” and is deemed to meet the requirements of Directive 92/42/EEC on the energy efficiency requirements for new hot water boilers fired with liquid or gaseous fuels:-

Type test for purpose of Regulation 5 certified by:  
Notified Body 0085.

Product/Production certified by:  
Notified Body 0085.

For use in GB/IE only.

These instructions include the Benchmark Commissioning Checklist and should be left with the User for safe keeping.

## Natural Gas

---

### Potterton Gold 24 HE

G.C.N° 47 590 05

### Potterton Gold 28 HE

G.C.N° 47 590 06

### Potterton Gold 33 HE

G.C.N° 47 590 19

## Building Regulations and the Benchmark Commissioning Checklist

Building Regulations (England & Wales) require notification of the installation of a heating appliance to the relevant Local Authority Building Control Department. From 1 April 2005 this can be achieved via a Competent Persons Self Certification Scheme as an option to notifying the Local Authority directly. Similar arrangements will follow for Scotland and will apply in Northern Ireland from 1 January 2006.

CORGI operate a Self Certification Scheme for gas heating appliances.

These arrangements represent a change from the situation whereby compliance with Building Regulations was accepted as being demonstrated by completion of the Benchmark Logbook (which was then left on site with the customer).

With the introduction of Self Certification Schemes, the Benchmark Logbook is being withdrawn. However, a similar document in the form of a commissioning checklist and service interval record is incorporated at the back of these instructions.

Potterton is a member of the Benchmark initiative and fully supports the aims of the programme. Its aim is to improve the standards of installation and commissioning of central heating systems in the UK and to encourage the regular servicing of all central heating systems to ensure safety and efficiency.

Building Regulations require that installations should comply with manufacturer's instructions. It is therefore important that the commissioning checklist is completed by the installer. The relevant section of Building Regulations only relates to dwellings. Therefore the checklist only applies if the appliance is being installed in a dwelling or some related structure.

The flowchart opposite gives guidance for installers on the process necessary to ensure compliance with Building Regulations.



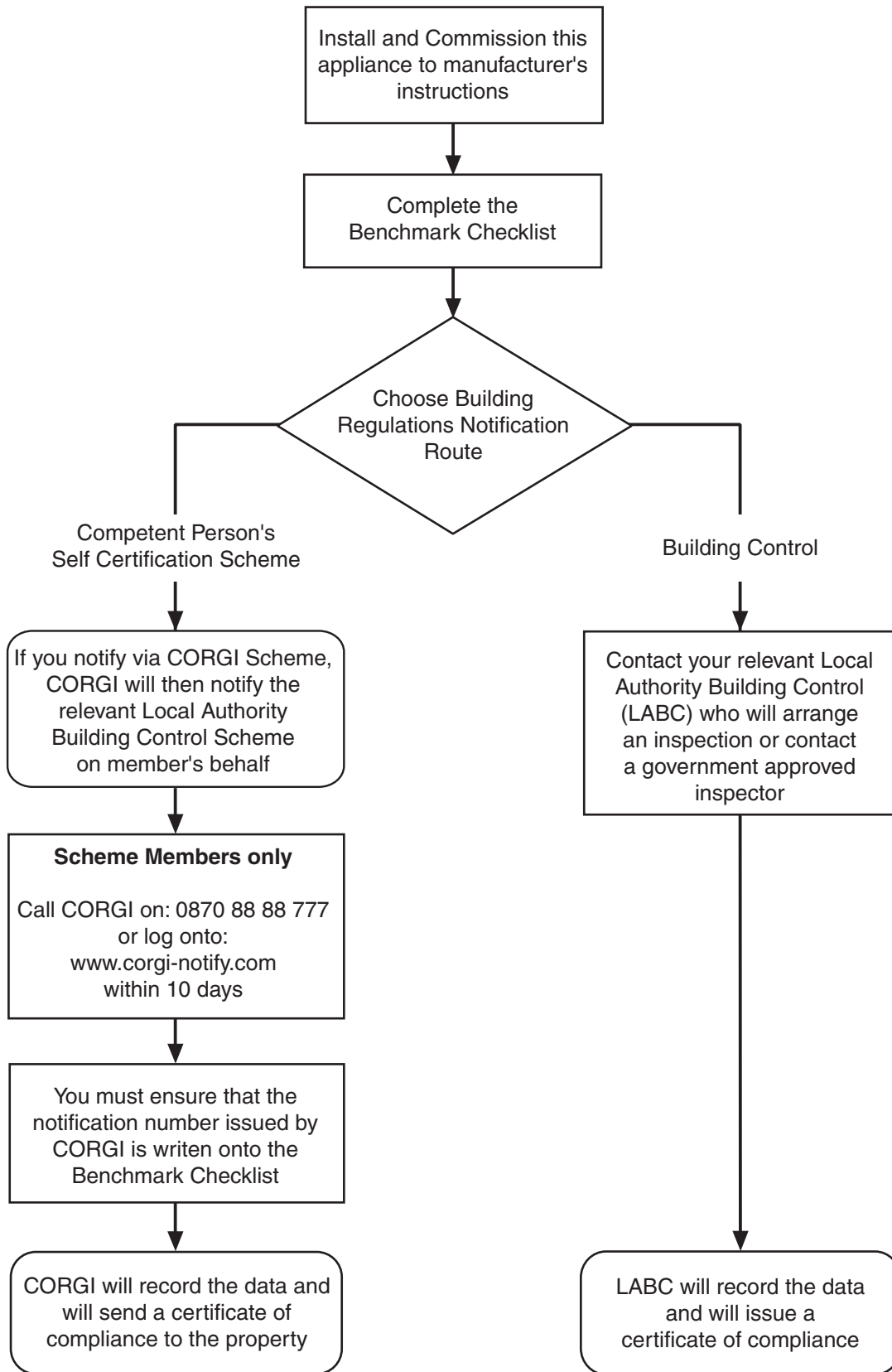

## LEGISLATION

**Potterton declare that no substances harmful to health are contained in the appliance or used during appliance manufacture.**

### IMPORTANT - Installation, Commissioning, Service & Repair

This appliance must be installed in accordance with the manufacturer's instructions and the regulations in force. Read the instructions fully before installing or using the appliance.

In GB, this must be carried out by a competent person as stated in the Gas Safety (Installation & Use) Regulations.

**Definition of competence:** A person who works for a CORGI registered company and holding current certificates in the relevant ACS modules, is deemed competent.

In IE, this must be carried out by a competent person as stated in I.S. 813 "Domestic Gas Installations".

**Lifting** - This product should be lifted and handled by two people. Stooping should be avoided and protective equipment worn where necessary. Carrying & lifting equipment should be used as required, e.g. when installing in a loft space.

The addition of anything that may interfere with the normal operation of the appliance without express written permission from the manufacturer or his agent could invalidate the appliance warranty. In GB this could also infringe the Gas Safety (Installation and Use) Regulations.

**Warning** - Check the information on the data plate is compatible with local supply conditions.

**The appliance is suitable only for installation in GB and IE and should be installed in accordance with the rules in force, and only used in a suitably ventilated location.**

In GB, the installation must be carried out by a CORGI Registered Installer. It must be carried out in accordance with the relevant requirements of the:

- Gas Safety (Installation & Use) Regulations.
- The appropriate Building Regulations either The Building Regulations, The Building Regulations (Scotland), Building Regulations (Northern Ireland).
- The Water Fittings Regulations or Water Byelaws in Scotland.
- The Current I.E.E. Wiring Regulations.

Where no specific instructions are given, reference should be made to the relevant British Standard Code of Practice.

In IE, the installation must be carried out by a competent Person and installed in accordance with the current edition of I.S. 813 'Domestic Gas Installations', the current Building Regulations and reference should be made to the current ETCl rules for electrical installation.

**All systems must be thoroughly flushed and treated with inhibitor (see section 6.2).**

**Codes of Practice** - refer to the most recent version

**In GB the following Codes of Practice apply:**

Standard	Scope
BS 6891	Gas Installation.
BS 5546	Installation of hot water supplies for domestic purposes.
BS 5449	Forced circulation hot water systems.
BS 6798	Installation of gas fired hot water boilers.
BS 5440 Part 1	Flues.
BS 5440 Part 2	Ventilation.
BS 7074	Expansion vessels and ancillary equipment for sealed water systems.
BS 7593	Treatment of water in domestic hot water central heating systems.

**In IE the following Codes of Practice apply:**

Standard	Scope
I.S. 813	Domestic Gas Installations.
The following standards give valuable additional information;	
BS 5546	Installation of hot water supplies for domestic purposes.
BS 5449	Forced circulation hot water systems.
BS 7074	Expansion vessels and ancillary equipment for sealed water systems.
BS 7593	Treatment of water in domestic hot water central heating systems.

All CORGI registered installers carry a CORGI identification card and have a registration number. You can check your installer is registered by telephoning 0870 4012300 or writing to:-

1 Elmwood,  
Chineham Business Park,  
Crockford Lane,  
Basingstoke. RG24 8WG

or check online at [www.corgi-gas-safety.com](http://www.corgi-gas-safety.com)

# CONTENTS



Section	Page
1.0 Introduction	6
2.0 General Layout	7
3.0 Appliance Operation	8
4.0 Technical Data	9
5.0 Dimensions and Fixings	12
6.0 System Details	13
7.0 Site Requirements	16
8.0 Installation	22
9.0 Commissioning	28
10.0 Completion	31
11.0 Servicing	32
12.0 Changing Components	34
13.0 Combustion Check	43
14.0 Electrical	44
15.0 Short Parts List	45
16.0 Fault Finding	46
17.0 Notes	52
Benchmark Checklist	54

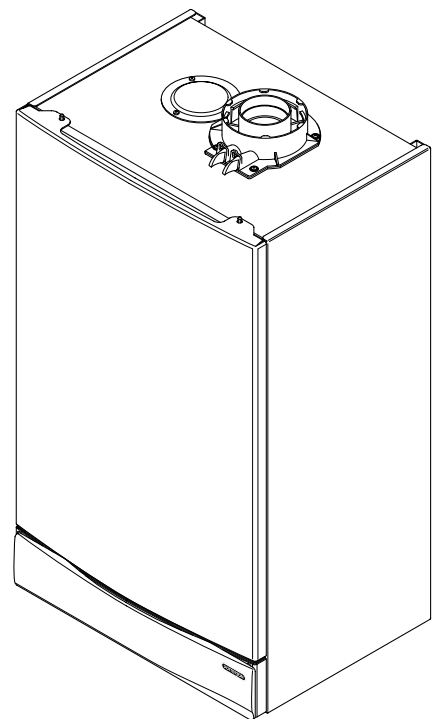

## 1.0 INTRODUCTION

### 1.1 Description

1. The Potterton Gold Combi HE is a fully automatic gas fired wall mounted condensing combination boiler. It is room sealed and fan assisted, and will serve central heating and mains fed domestic hot water.

2. The boiler is set to give a maximum output of :-

- 24 models - 24 kW DHW  
25.9 kW CH (Condensing)
- 28 models - 28 kW DHW  
25.9 kW CH (Condensing)
- 33 models - 33 kW DHW  
30.3 kW CH (Condensing)

3. It is designed for use on Natural Gas (G20).

4. The boiler is suitable for use only on fully pumped sealed heating systems. Priority is given to domestic hot water.

5. The boiler is supplied with a filling loop and integral timer.

6. The boiler data badge gives details of the model, serial number and Gas Council number and is situated on the control box. It is visible when the case front panel is removed (Fig. 1).

7. The boiler is intended to be installed in residential / commercial / light industrial E.M.C. environments on a governed meter supply only.

8. The boiler must be installed with one of the purpose designed flues such as the standard horizontal flue kit, part no. 5111073.

**9. All systems must be thoroughly flushed and treated with inhibitor (see section 6.2).**

### 1.2 Optional Extras

Various flue extensions, bends, vertical flue kits, etc. are available as optional extras. These are detailed in a separate publication.

**NOTE:** All illustrations show the Gold Combi 24 HE unless otherwise stated.

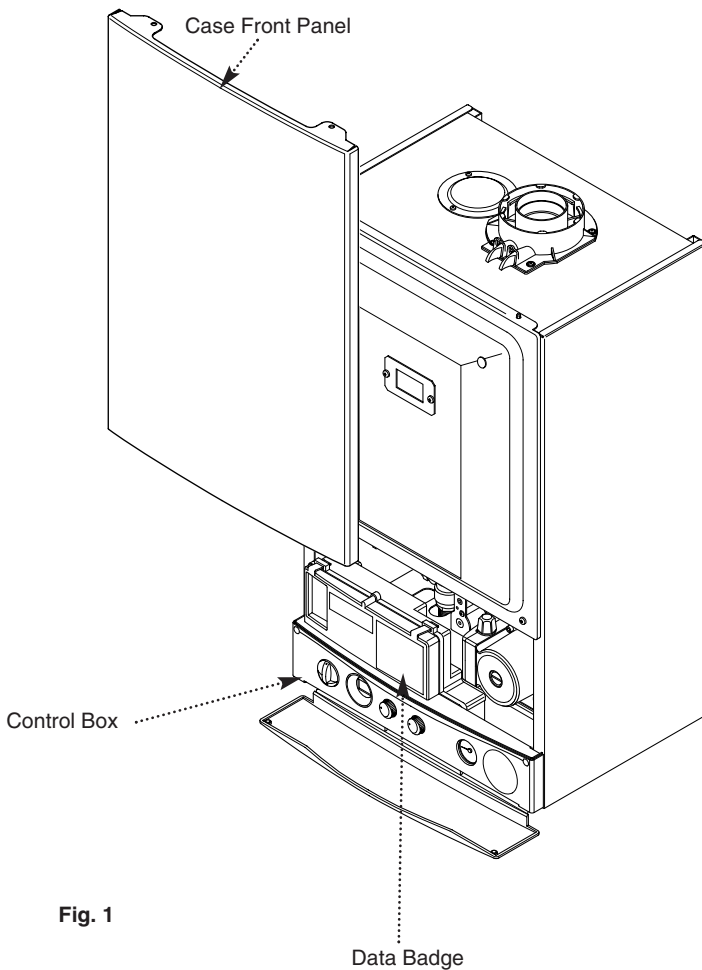

Fig. 1

## 2.0 GENERAL LAYOUT



### 2.1 Layout

1. Expansion Vessel
2. Automatic Air Vent
3. DHW Plate Heat Exchanger
4. Circulation Pump
5. Drain Off Point
6. Pressure Relief Valve
7. Integral Timer Position
8. Central Heating System Pressure Gauge
9. PCB
10. Control Box
11. 3-Way Valve Assembly
12. Condensate Trap
13. Flame Sensing Electrode
14. Spark Electrode
15. Primary Heat Exchanger
16. Fan Assembly
17. On/Off/Reset Selector Switch
18. Central Heating Temperature Control
19. Hot Water Temperature Control
20. Venturi
21. Air/Gas Collector
22. Combustion Box Cover & Burner
23. Igniter
24. Burner On Light
25. Central Heating Mode Light
26. Domestic Hot Water Mode Light
27. Display

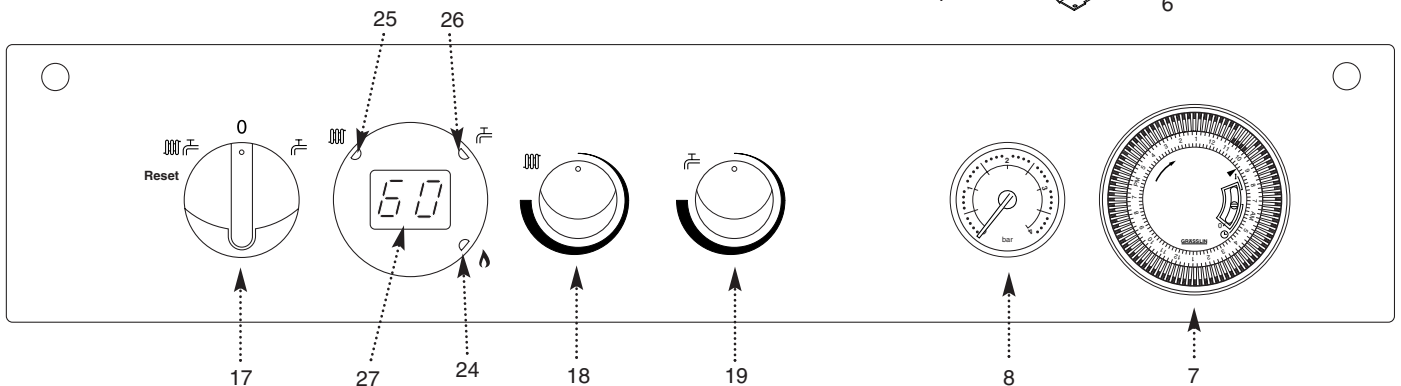
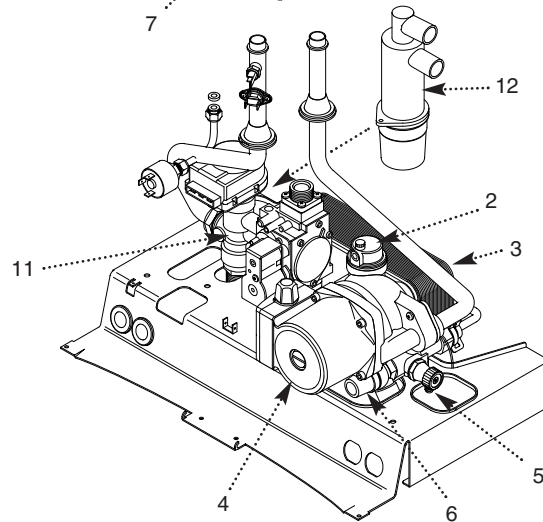
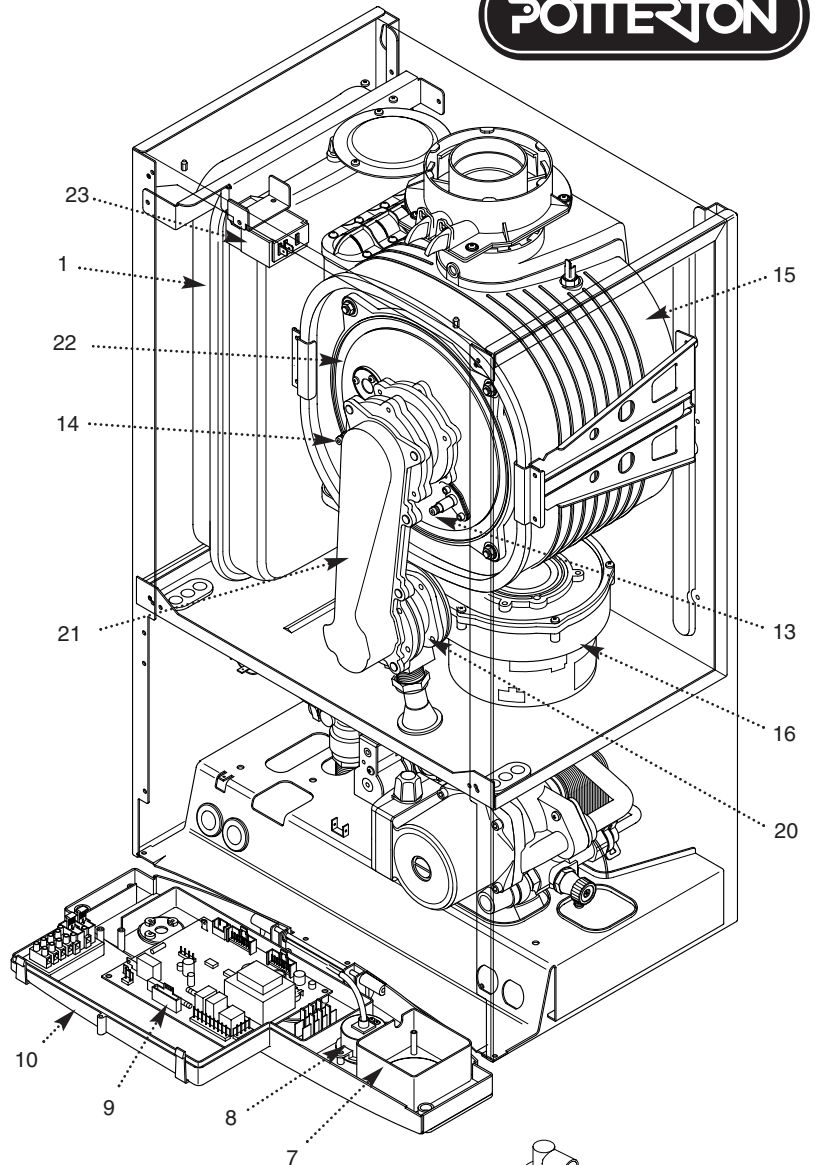

### 3.0 APPLIANCE OPERATION

#### 3.1 Central Heating Mode (Fig. 2)

1. With a demand for heating, the pump circulates water through the primary circuit.
2. Once main burner ignites the fan speed controls the gas rate to maintain the heating temperature measured by the temperature sensor.
3. When the flow temperature exceeds the setting temperature, a 3 minute delay occurs before the burner relights automatically (anti-cycling). The pump continues to run during this period.
4. When the demand is satisfied the burner is extinguished and the pump continues to run for a period of 3 minutes (Pump Overrun).

#### 3.2 Domestic Hot Water Mode (Fig. 3)

1. Priority is given to the domestic hot water supply. A demand at a tap or shower will override any central heating requirement.
2. The flow of water will operate the Hall Effect Sensor which requests the 3 way valve to change position. This will allow the pump to circulate the primary water through the DHW plate heat exchanger.
3. The burner will light automatically and the temperature of the domestic hot water is controlled by the temperature sensor.
4. When the domestic hot water demand ceases the burner will extinguish and the diverter valve will remain in the domestic hot water mode, unless there is a demand for central heating.

**IMPORTANT:** When the selector switch is in the '0' (Off) position the electrical supply to the boiler is isolated. The boiler will not operate and the integral timer will require resetting once the selector switch is set to either Position (i) or Position (ii).

#### 3.3 Frost Protection Mode

1. The frost protection mode is integral to the appliance and functions only with the selector switch (see Section 2.1) in the domestic hot water and central heating position. If the system temperature falls below 5° C then the boiler will fire on its minimum setting until a flow temperature of 30° C is reached. Further protection can be incorporated by using a system frost thermostat.

#### 3.4 Pump Protection

1. With the selector switch (see Section 2.1) in either the central heating or central heating and domestic hot water position, the pump will automatically operate for 1 minute in every 24 hours to prevent sticking.

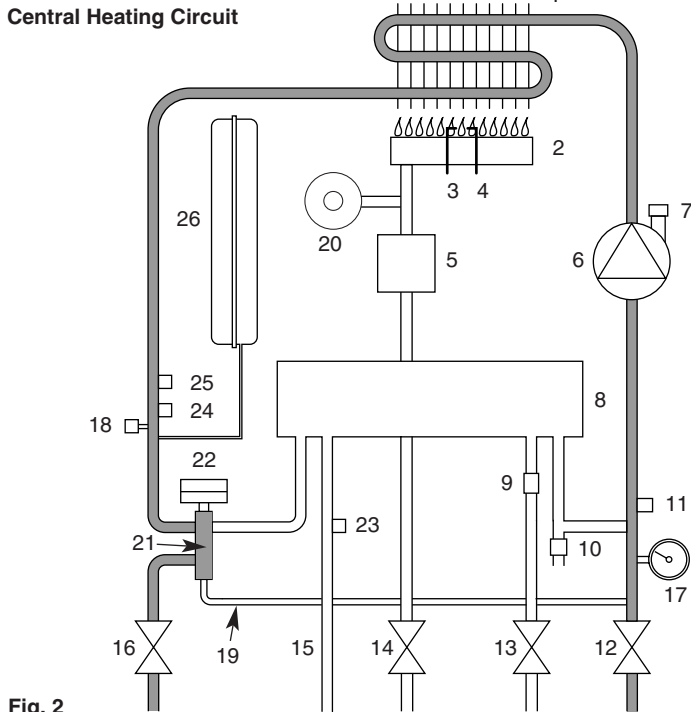

Fig. 2

#### Key

- |   |   |
|---|---|
| 1 Primary Heat Exchanger                    | 15 Domestic Hot Water Outlet                  |
| 2 Burner                                    | 16 Heating Flow                               |
| 3 Ignition Electrode                        | 17 Pressure Gauge                             |
| 4 Flame Sensing Electrode                   | 18 Water Pressure Sensor                      |
| 5 Gas Valve                                 | 19 Automatic By-Pass                          |
| 6 Pump                                      | 20 Fan  |
| 7 Automatic Air Vent                        | 21 Diverter Valve Assembly                    |
| 8 Plate Heat Exchanger                      | 22 Diverter Valve Motor                       |
| 9 Flow Sensor with Filter & Regulator       | 23 Domestic Hot Water Flow Temperature Sensor |
| 10 Pressure Relief Valve                    | 24 Safety Thermostat                          |
| 11 Boiler Drain Point                       | 25 Central Heating Temperature Sensor         |
| 12 Heating Return                           | 26 Expansion Vessel                           |
| 13 Cold Water Inlet On/Off Valve and Filter |   |
| 14 Gas Inlet                                |   |

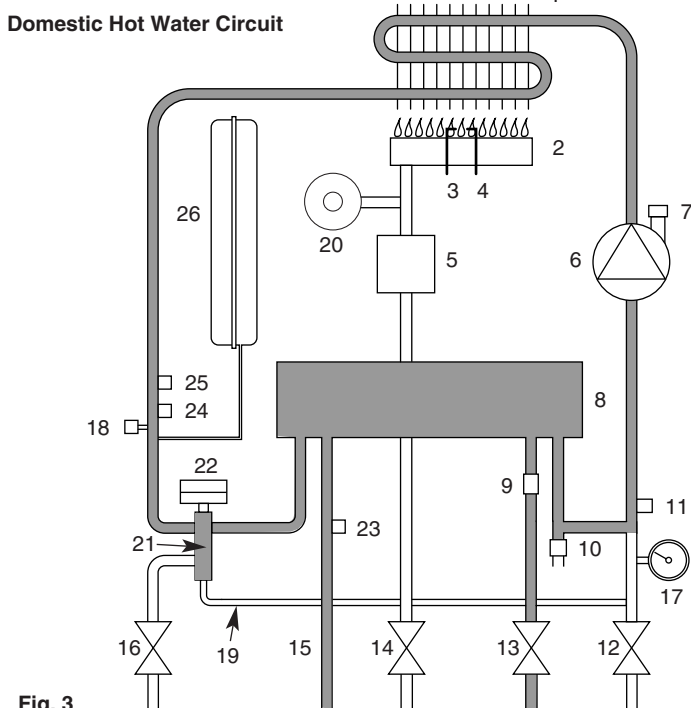

Fig. 3



## 4.0 TECHNICAL DATA



### 4.1 Gold Combi 24 HE

<b>Appliance Type</b>	C <sub>13</sub>	C <sub>33</sub>
<b>Appliance Category</b>	CAT I <sub>2H</sub>	
<b>Heat Input CH (Net)</b>		
	Max	Min
kW	24.7	7
<b>Heat Input CH (Gross)</b>		
	Max	Min
kW	27.4	7.8
<b>Heat Output CH (Non-Condensing)</b>		
	Max	Min
kW	24	6.8
<b>Heat Output CH (Condensing)</b>		
	Max	Min
kW	25.9	7.4
<b>Heat Input DHW (Net)</b>		
	Max	
kW	24.7	
<b>Heat Input DHW (Gross)</b>		
	Max	
kW	27.4	
<b>Heat Output DHW</b>		
	Max	
kW	24	
<b>Max Gas Rate</b> (Natural Gas - G20) (After 10 mins)		
m <sup>3</sup> /h	2.61	
<b>Inlet Pressure</b> (Natural Gas - G20)		
mbar	20	
<b>Injector</b> (Natural Gas - G20)		
	7.5mm	
<b>Electrical Supply</b>		
	230V~ 50Hz	
(Appliance must be connected to an earthed supply)		

<b>Power Consumption</b>	155W
<b>Electrical Protection</b>	IPX0D
<b>External Fuse Rating</b>	3A
<b>Internal Fuse Rating</b>	F2L
<b>NO<sub>x</sub> Class</b>	5
<b>Condensate Drain</b>	
To accept 21.5mm (3/4 in) plastic waste pipe	
<b>Flue Terminal Dimensions</b>	Diameter 100mm Projection 125mm
<b>Connections</b>	
	copper tails
Gas Supply	- 22mm
Central Heating Flow	- 22mm
Central Heating Return	- 22mm
Cold Water Mains Inlet	- 15mm
DHW Flow	- 15mm
Pressure Relief Discharge	- 15mm
<b>Outer Case Dimensions</b>	
Casing Height	- 780mm
Overall Height Inc Flue	
Elbow	- 965mm
Casing Width	- 450mm
Casing Depth	- 345mm
<b>Clearances</b>	
Above Casing	200 mm Min
Below Casing	200 mm Min
Front	450 mm Min (For Servicing)
Front	5 mm Min (In Operation)
L.H. Side	5 mm Min
R.H. Side	5 mm Min (In Operation)
<b>Weights</b>	
	kg
Packaged Boiler Carton	56.5
Installation Lift Weight	45

<b>Central Heating Primary Circuit Pressures</b>	
	bar
Safety Discharge	3
Max Operating	2.5
Min Operating	0.5
Recommended Operating Range	1-2
<b>DHW Circuit Pressures</b>	
	bar
Max Operating	8
Min Operating	0.15
<b>Flow Rates</b>	
	l/min
DHW Flow Rate @ 30°C Rise	11.43
DHW Flow Rate @ 35°C Rise	9.8
Min Working DHW Flow Rate	2
<b>Pump</b>	
Available Head	See graph below
<b>Expansion Vessel - (For Central Heating only. Integral with appliance)</b>	
	bar
Min Pre-charge Pressure	0.5
	litre
Max Capacity of CH System	125
Primary Water Content of Boiler (unpressurised)	2.5
<b>Temperatures</b>	
C.H. Flow Temp (adjustable)	25°C to 80°C max (± 5°C)
D.H.W. Flow Temp (adjustable)	35°C to 60°C max (± 5°C) dependent upon flow rate

Pump - Available Head

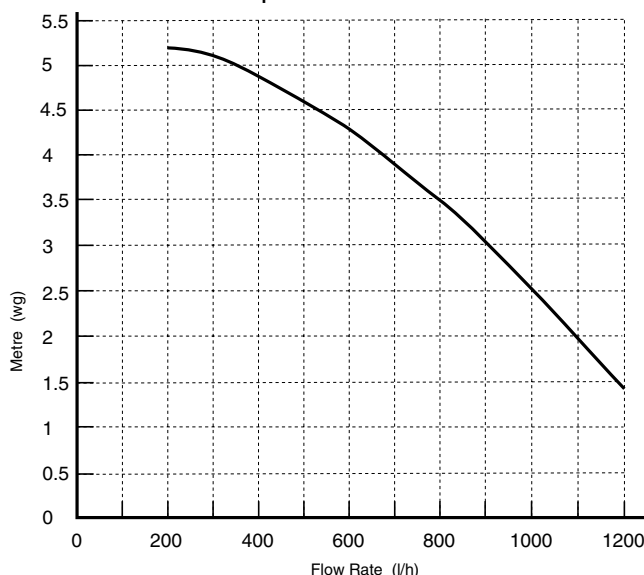

## 4.0 TECHNICAL DATA

### 4.2 Gold Combi 28 HE

<b>Appliance Type</b>	C <sub>13</sub>	C <sub>33</sub>
<b>Appliance Category</b>	CAT I <sub>2H</sub>	
<b>Heat Input CH (Net)</b>		
	Max	Min
kW	24.7	9
<b>Heat Input CH (Gross)</b>		
	Max	Min
kW	27.4	10
<b>Heat Output CH (Non-Condensing)</b>		
	Max	Min
kW	24	8.7
<b>Heat Output CH (Condensing)</b>		
	Max	Min
kW	25.9	9.5
<b>Heat Input DHW (Net)</b>		
	Max	
kW	28.9	
<b>Heat Input DHW (Gross)</b>		
	Max	
kW	32.1	
<b>Heat Output DHW</b>		
	Max	
kW	28	
<b>Max Gas Rate</b> (Natural Gas - G20) (After 10 mins)		
m <sup>3</sup> /h	3.1	
<b>Inlet Pressure</b> (Natural Gas - G20)		
mbar	20	
<b>Injector</b> (Natural Gas - G20)		
	7.5mm	
<b>Electrical Supply</b>		
	230V~ 50Hz	
(Appliance must be connected to an earthed supply)		

<b>Power Consumption</b>	155W
<b>Electrical Protection</b>	IPX0D
<b>External Fuse Rating</b>	3A
<b>Internal Fuse Rating</b>	F2L
<b>NO<sub>x</sub> Class</b>	5
<b>Condensate Drain</b>	
To accept 21.5mm (¾ in) plastic waste pipe	
<b>Flue Terminal Dimensions</b>	Diameter 100mm Projection 125mm
<b>Connections</b>	copper tails
Gas Supply	- 22mm
Central Heating Flow	- 22mm
Central Heating Return	- 22mm
Cold Water Mains Inlet	- 15mm
DHW Flow	- 15mm
Pressure Relief Discharge	- 15mm
<b>Outercase Dimensions</b>	
Casing Height	- 780mm
Overall Height Inc Flue	
Elbow	- 965mm
Casing Width	- 450mm
Casing Depth	- 345mm
<b>Clearances</b>	
Above Casing	200 mm Min
Below Casing	200 mm Min
Front	450 mm Min (For Servicing)
Front	5 mm Min (In Operation)
L.H. Side	5 mm Min
R.H. Side	5 mm Min (In Operation)
<b>Weights</b>	
Packaged Boiler Carton	56.5 kg
Installation Lift Weight	45 kg

<b>Central Heating Primary Circuit Pressures</b>	
	bar
Safety Discharge	3
Max Operating	2.5
Min Operating	0.5
Recommended Operating Range	1-2
<b>DHW Circuit Pressures</b>	bar
Max Operating	8
Min Operating	0.15
<b>Flow Rates</b>	
	l/min
DHW Flow Rate @ 30°C Rise	13.3
DHW Flow Rate @ 35°C Rise	11.5
Min Working DHW Flow Rate	2
<b>Pump</b>	
Available Head	See graph below
<b>Expansion Vessel - (For Central Heating only. Integral with appliance)</b>	
	bar
Min Pre-charge Pressure	0.5
	litre
Max Capacity of CH System	125
Primary Water Content of Boiler (unpressurised)	2.5
<b>Temperatures</b>	
C.H. Flow Temp (adjustable)	25°C to 80°C max (± 5°C)
D.H.W. Flow Temp (adjustable)	35°C to 60°C max (± 5°C) dependent upon flow rate

Pump - Available Head

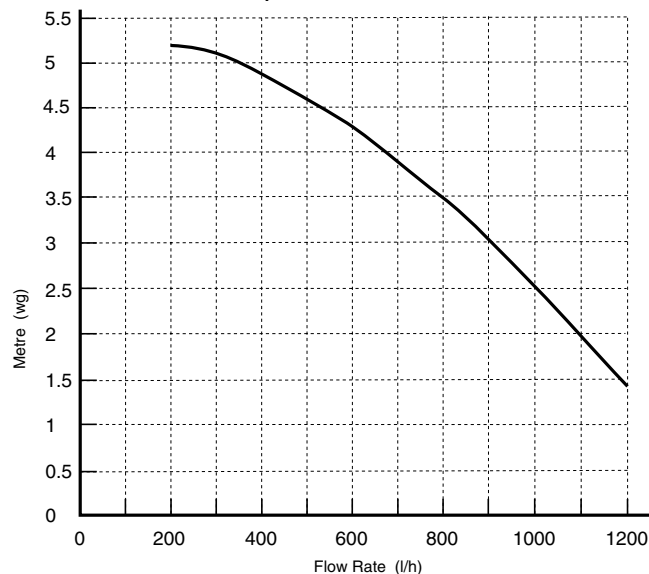

## 4.0 TECHNICAL DATA



### 4.3 Gold Combi 33 HE

<b>Appliance Type</b>	C <sub>13</sub>	C <sub>33</sub>
<b>Appliance Category</b>	CAT I <sub>2H</sub>	
<b>Heat Input CH (Net)</b>		
	Max	Min
kW	28.9	9.7
<b>Heat Input CH (Gross)</b>		
	Max	Min
kW	32.1	10.8
<b>Heat Output CH (Non-Condensing)</b>		
	Max	Min
kW	28	9.4
<b>Heat Output CH (Condensing)</b>		
	Max	Min
kW	30.3	10.2
<b>Heat Input DHW (Net)</b>		
	Max	
kW	34	
<b>Heat Input DHW (Gross)</b>		
	Max	
kW	37.7	
<b>Heat Output DHW</b>		
	Max	
kW	33	
<b>Max Gas Rate</b> (Natural Gas - G20) (After 10 mins)		
m <sup>3</sup> /h	3.6	
<b>Inlet Pressure</b> (Natural Gas - G20)		
mbar	20	
<b>Injector</b> (Natural Gas - G20)		
	12mm	
<b>Electrical Supply</b>		
	230V~ 50Hz (Appliance must be connected to an earthed supply)	

<b>Power Consumption</b>	160W	
<b>Electrical Protection</b>	IPX0D	
<b>External Fuse Rating</b>	3A	
<b>Internal Fuse Rating</b>	F2L	
<b>NO<sub>x</sub> Class</b>	5	
<b>Condensate Drain</b> To accept 21.5mm (3/4 in) plastic waste pipe		
<b>Flue Terminal Dimensions</b>	Diameter	100mm
	Projection	125mm
<b>Connections</b>		
	copper tails	
Gas Supply	-	22mm
Central Heating Flow	-	22mm
Central Heating Return	-	22mm
Cold Water Mains Inlet	-	15mm
DHW Flow	-	15mm
Pressure Relief Discharge	-	15mm
<b>Outercase Dimensions</b>		
Casing Height	-	780mm
Overall Height Inc Flue Elbow	-	965mm
Casing Width	-	450mm
Casing Depth	-	345mm
<b>Clearances</b>		
Above Casing	200 mm Min	
Below Casing	200 mm Min	
Front	450 mm Min (For Servicing)	
Front	5 mm Min (In Operation)	
L.H. Side	5 mm Min	
R.H. Side	5 mm Min (In Operation)	
<b>Weights</b>		
		kg
Packaged Boiler Carton		57.5
Installation Lift Weight		46

<b>Central Heating Primary Circuit Pressures</b>	
	bar
Safety Discharge	3
Max Operating	2.5
Min Operating	0.5
Recommended Operating Range	1-2
<b>DHW Circuit Pressures</b>	
	bar
Max Operating	8
Min Operating	0.15
<b>Flow Rates</b>	
	l/min
DHW Flow Rate @ 30°C Rise	15.7
DHW Flow Rate @ 35°C Rise	13.5
Min Working DHW Flow Rate	2
<b>Pump</b>	
Available Head	See graph below
<b>Expansion Vessel - (For Central Heating only. Integral with appliance)</b>	
	bar
Min Pre-charge Pressure	0.5
	litre
Max Capacity of CH System	155
<b>Temperatures</b>	
C.H. Flow Temp (adjustable)	
	25°C to 80°C max (± 5°C)
D.H.W. Flow Temp (adjustable)	
	35°C to 60°C max (± 5°C) dependent upon flow rate

Pump - Available Head

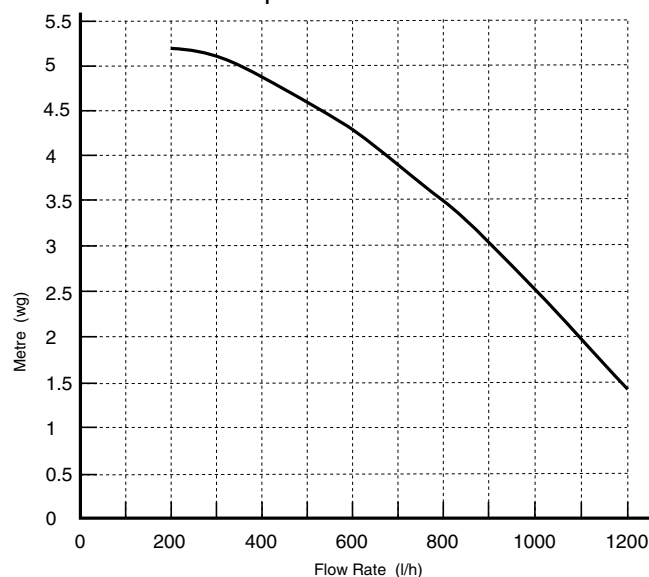

# 5.0 DIMENSIONS AND FIXINGS

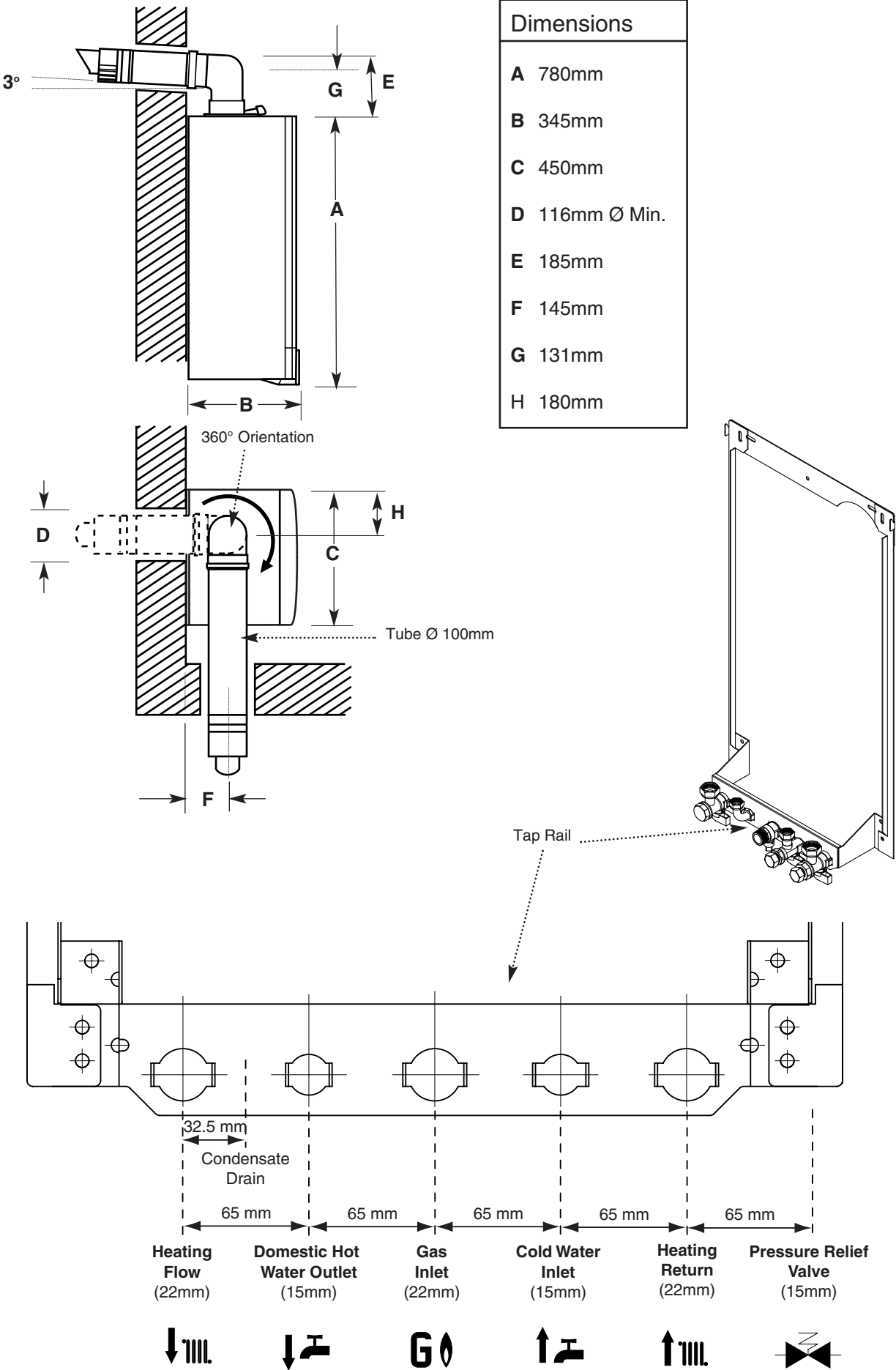

## 6.0 SYSTEM DETAILS



### 6.1 Information

1. The Potterton Gold HE Condensing Combination Boiler is a 'Water Byelaws Scheme - Approved Product'. To comply with the Water Byelaws your attention is drawn to the following installation requirements and notes (IRN).

- a) IRN 001 - See text of entry for installation requirements and notes.
- b) IRN 302 - Byelaw 14.

2. Reference to the WRc publications, 'Water fittings and materials directory' and 'Water supply byelaws guide' give full details of byelaws and the IRNs.

### 6.2 Central Heating Circuit

1. The appliance is suitable for fully pumped SEALED SYSTEMS ONLY.

#### Treatment of Water Circulating Systems

- All recirculatory water systems will be subject to corrosion unless an appropriate water treatment is applied. This means that the efficiency of the system will deteriorate as corrosion sludge accumulates within the system, risking damage to pump and valves, boiler noise and circulation problems.
- When upgrading existing systems that exhibit evidence of sludging, it is advisable to clean the system prior to treatment in order to remove any sludge and reduce the likelihood of these deposits damaging new components.
- When fitting new systems flux will be evident within the system, which can lead to damage of system components.
- All systems must be thoroughly drained and flushed out. The recommended flushing and cleansing agents are Betz-Dearborn Sentinel X300 or X400 and Fernox Superfloc Universal Cleanser which should be used following the flushing agent manufacturer's instructions.
- System additives - corrosion inhibitors and flushing agents/descalers should comply to BS7593 requirements. The only system additives recommended are Betz-Dearborn Sentinel X100 and Fernox-Copal which should be used following the inhibitor manufacturer's instructions.

**Failure to flush and add inhibitor to the system will invalidate the appliance warranty.**

- It is important to check the inhibitor concentration after installation, system modification and at every service in accordance with the manufacturer's instructions. (Test kits are available from inhibitor stockists.)
- For information or advice regarding any of the above contact Technical Enquiries.

### 6.3 Bypass

1. The boiler is fitted with an automatic integral bypass.

### 6.4 System Control

1. A 24 hour electro - mechanical timer is supplied fitted to the boiler.

2. Further external controls (e.g. room thermostat) should be fitted to optimise the economical operation of the boiler.

## 6.0 SYSTEM DETAILS

### 6.5 System Filling and Pressurising

1. A filling point connection on the central heating return pipework must be provided to facilitate initial filling and pressurising and also any subsequent water loss replacement/refilling.

2. There are connection points on the mains cold water inlet and central heating return isolating taps (Fig. 5) to which the filling loop kit supplied can be assembled. If the boiler is to be installed in an inaccessible location (e.g. loft space) the filling point should remain accessible. Also the fitting of an additional pressure gauge in a visible position is recommended. The kit supplied can still be used for this elsewhere on the system, or if necessary a more suitable proprietary kit can be fitted.

3. The filling method adopted must be in accordance with all relevant water supply regulations and use approved equipment.

4. Your attention is drawn to:  
for GB: Guidance G24.2 and recommendation R24.2 of the Water Regulations Guide.  
for IE: the current edition of I.S. 813 "Domestic Gas Installations".

5. The sealed primary circuits may be filled or replenished by means of a temporary connection between the circuit and a supply pipe, provided a 'Listed' double check valve or some other no less effective backflow prevention device is permanently connected at the inlet to the circuit and the temporary connection is removed after use.

### 6.6 Expansion Vessel (Central Heating only)

1. The appliance expansion vessel is pre-charged to 0.5 bar. Therefore, the minimum cold fill pressure is 0.5 bar. The vessel is suitable for correct operation for system capacities up to 125 litres. For greater system capacities an additional expansion vessel must be fitted. For GB refer to BS 7074 Pt 1. For IE, the current edition of I.S. 813 "Domestic Gas Installations".

### 6.7 Pressure Relief Valve (Fig. 6)

1. The pressure relief valve is set at 3 bar, therefore all pipework, fittings, etc. should be suitable for pressures in excess of 3 bar and temperature in excess of 100°C.

2. The pressure relief discharge pipe should be not less than 15mm dia, run continuously downward, and discharge outside the building, preferably over a drain. It should be routed in such a manner that no hazard occurs to occupants or causes damage to wiring or electrical components. The end of the pipe should terminate facing down and towards the wall.

3. The discharge must not be above a window, entrance or other public access. Consideration must be given to the possibility that boiling water/steam could discharge from the pipe.

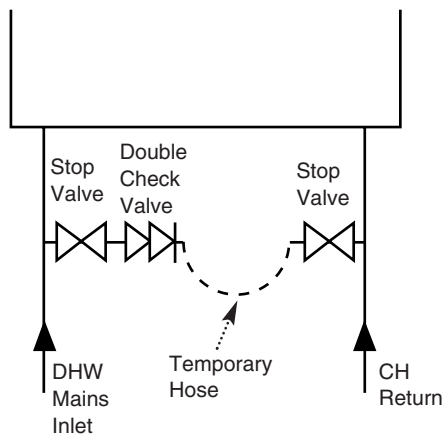
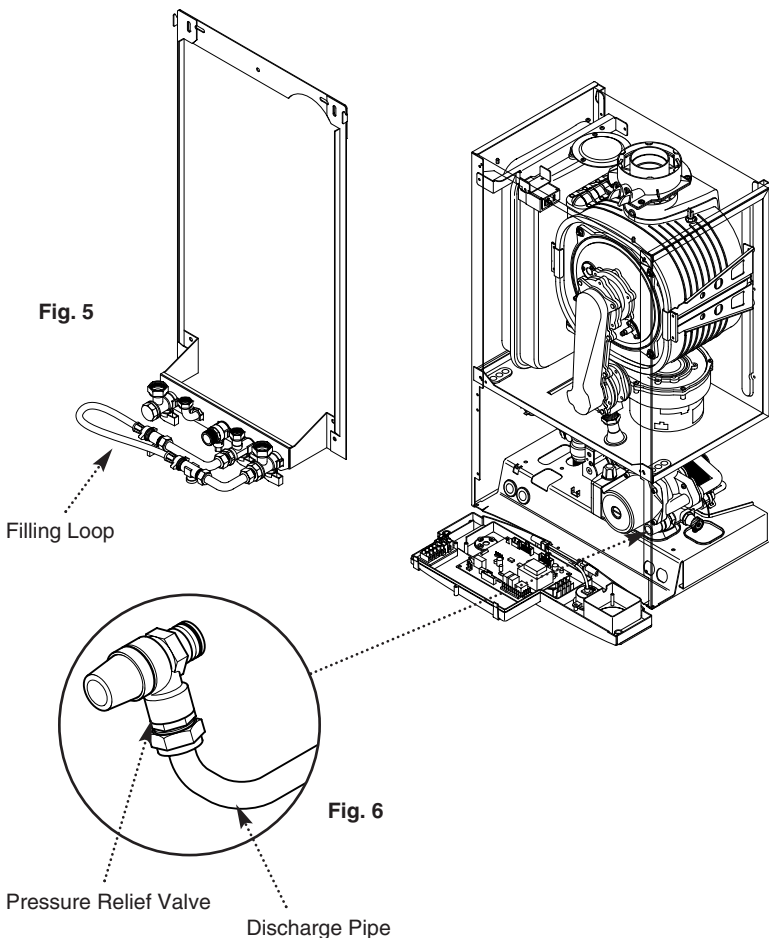

Fig. 4



## 6.0 SYSTEM DETAILS

### 6.8 Domestic Hot Water Circuit (Fig. 7)

1. All DHW circuits, connections, fittings, etc. should be fully in accordance with relevant standards and water supply regulations.

2. Your attention is drawn to:  
for GB: Guidance G17 to G24 and recommendation R17 to R24 of the Water Regulations Guide.  
for IE: the current edition of I.S. 813 "Domestic Gas Installations".

3. A single check valve must be fitted as shown in Fig. 7 to prevent backflow to the supply pipe and to ensure the efficient operation of the expansion vessel which is required to accommodate the thermal expansion of the water.

4. When the domestic water system includes any device which prevents water expanding back towards the supply (check valve, loose jumpered stopcock, water meter, water treatment device) then an expansion vessel must be fitted (eg. Zilmet 160ml, R $\frac{1}{2}$  15bar).

5. If the hot water expansion is not provided for, then high pressures can develop which may result in damage to fittings and devices on the system.

6. The boiler's maximum working mains pressure is 8 bar, therefore all pipework, connections, fittings, etc. should be suitable for pressures in excess of 8 bar. A pressure reducing valve must be fitted for pressures in excess of 8 bar. The manufacturer of any outlet fittings, such as a shower valve, may require a lower maximum pressure. The pressure reduction must take account of all fittings connected to the DHW system.

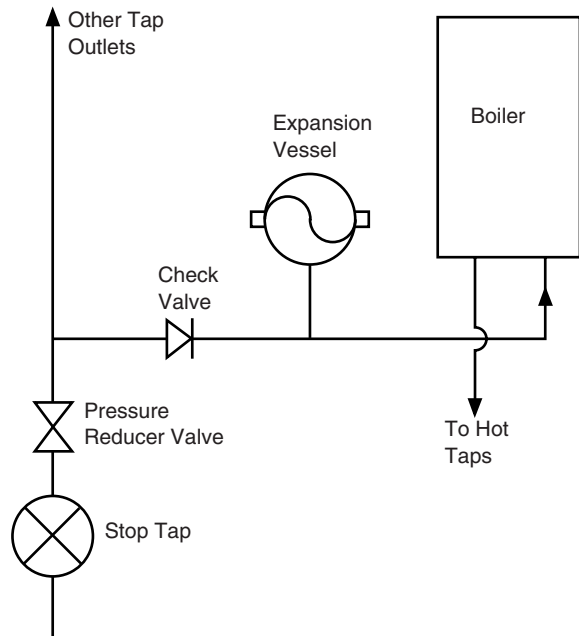

Fig. 7

### 6.9 Showers

1. If a shower control is supplied from the appliance it should be of the thermostatic or pressure balanced type. Thermostatic type shower valves provide the best comfort and guard against water at too high a temperature. Existing controls may not be suitable - refer to the shower valve manufacturer.

### 6.10 Hard Water Areas

1. If the area of the installation is recognised as a HARD WATER AREA then a suitable device should be fitted to treat the mains water supply to the boiler. Contact your Water Distribution Company for advice on suitable devices.

## 7.0 SITE REQUIREMENTS

### 7.1 Location

1. The boiler may be fitted to any suitable wall with the flue passing through an outside wall or roof and discharging to atmosphere in a position permitting satisfactory removal of combustion products and providing an adequate air supply. The boiler should be fitted within the building unless otherwise protected by a suitable enclosure i.e. garage or outhouse. (The boiler may be fitted inside a cupboard-see Section 7.3).

2. If the boiler is sited in an unheated enclosure then it is recommended to leave the ON/OFF Selector Switch in the domestic hot water and central heating position to give frost protection.

3. If the boiler is fitted in a room containing a bath or shower reference must be made to the relevant requirements.

In GB this is the current I.E.E. Wiring Regulations and Building Regulations.

In IE reference should be made to the current edition of I.S. 813 "Domestic Gas Installations" and the current ETCI rules.

4. If the boiler is to be fitted into a building of timber frame construction then reference must be made to the current edition of Institute of Gas Engineers Publication IGE/UP/7 (Gas Installations in Timber Framed Housing).

### 7.2 Clearances (Figs. 8 & 9)

1. A flat vertical area is required for the installation of the boiler.

2. These dimensions include the necessary clearances around the boiler for case removal, spanner access and air movement. Additional clearances may be required for the passage of pipes around local obstructions such as joists running parallel to the front face of the boiler.

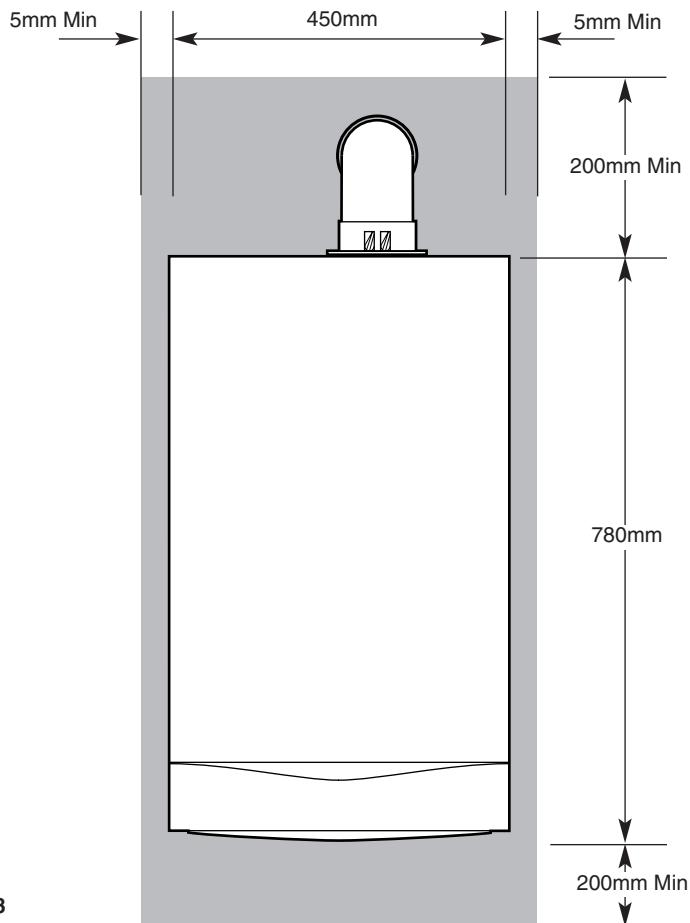

Fig. 8

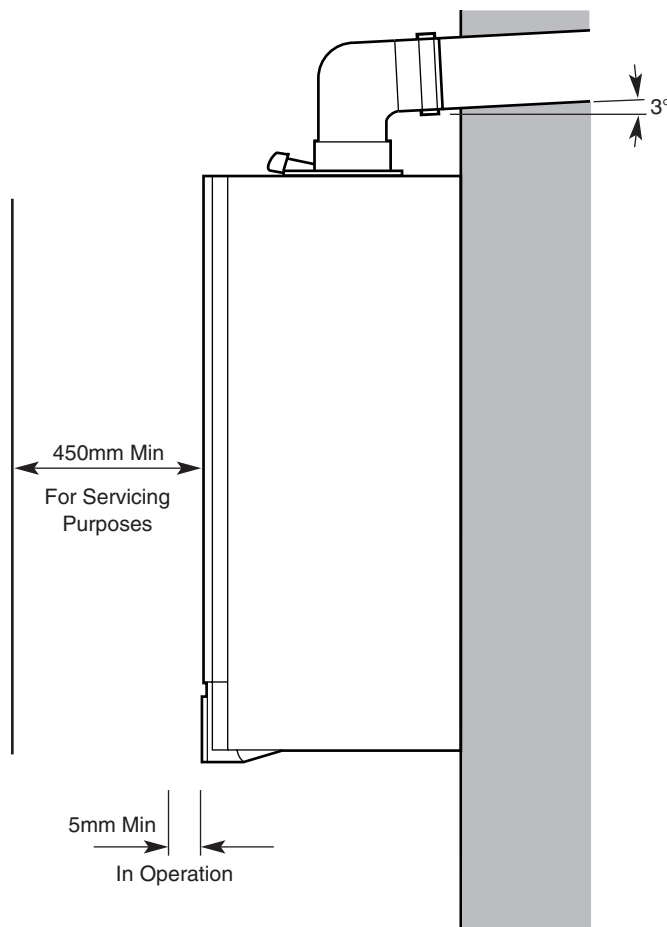

Fig. 9



## 7.0 SITE REQUIREMENTS



### 7.3 Ventilation of Compartments

1. Where the appliance is installed in a cupboard or compartment, no air vents are required.
2. BS 5440: Part 2 refers to room sealed appliances installed in compartments. The appliance will run sufficiently cool without ventilation.

### 7.4 Gas Supply

1. The gas installation should be in accordance with the relevant standards. In GB this is BS 6891. In IE this is the current edition of I.S. 813 "Domestic Gas Installations".
2. The connection to the appliance is a 22mm copper tail located at the rear of the gas service cock (Fig. 10).
3. Ensure that the pipework from the meter to the appliance is of adequate size. Do not use pipes of a smaller diameter than the boiler gas connection (22mm).

### 7.5 Electrical Supply

1. External wiring must be correctly earthed, polarised and in accordance with relevant regulations/rules. In GB this is the current I.E.E. Wiring Regulations. In IE reference should be made to the current edition of ETCI rules.
2. The mains supply is 230V ~ 50Hz fused at 3A.

**NOTE:** The method of connection to the electricity supply must facilitate complete electrical isolation of the appliance.

Connection may be via a fused double-pole isolator with a contact separation of at least 3mm in all poles and servicing the boiler and system controls only.

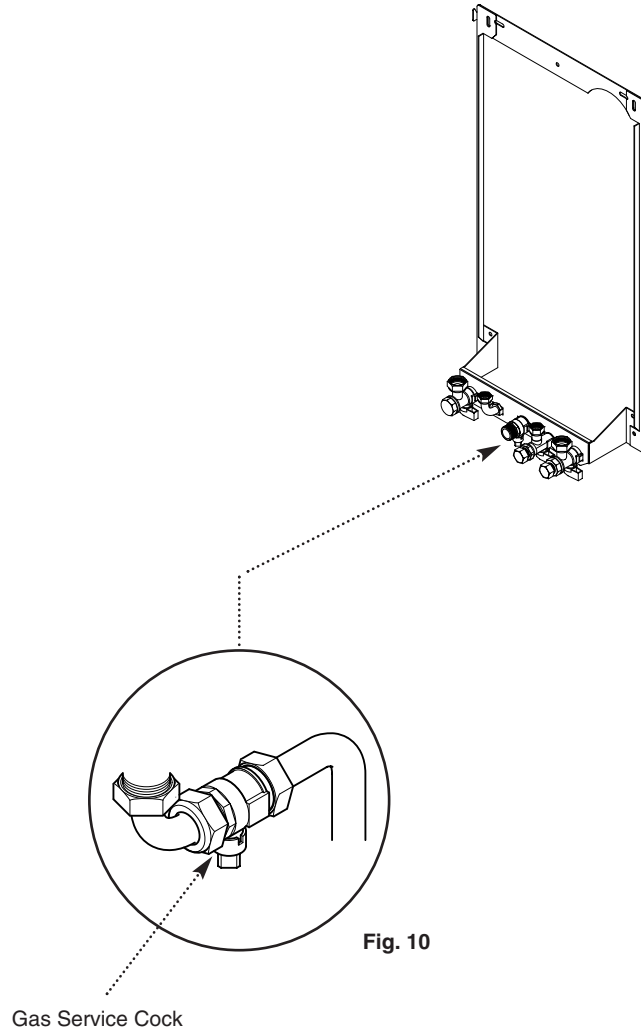

Fig. 10

## 7.0 SITE REQUIREMENTS

### 7.6 Condensate Drain

**FAILURE TO INSTALL THE CONDENSATE DISCHARGE PIPEWORK CORRECTLY WILL AFFECT THE RELIABLE OPERATION OF THE BOILER**

**The condensate discharge pipe MUST NOT RISE at any point along its length. There MUST be a fall of AT LEAST 2.5° (50mm per metre) along the entire run.**

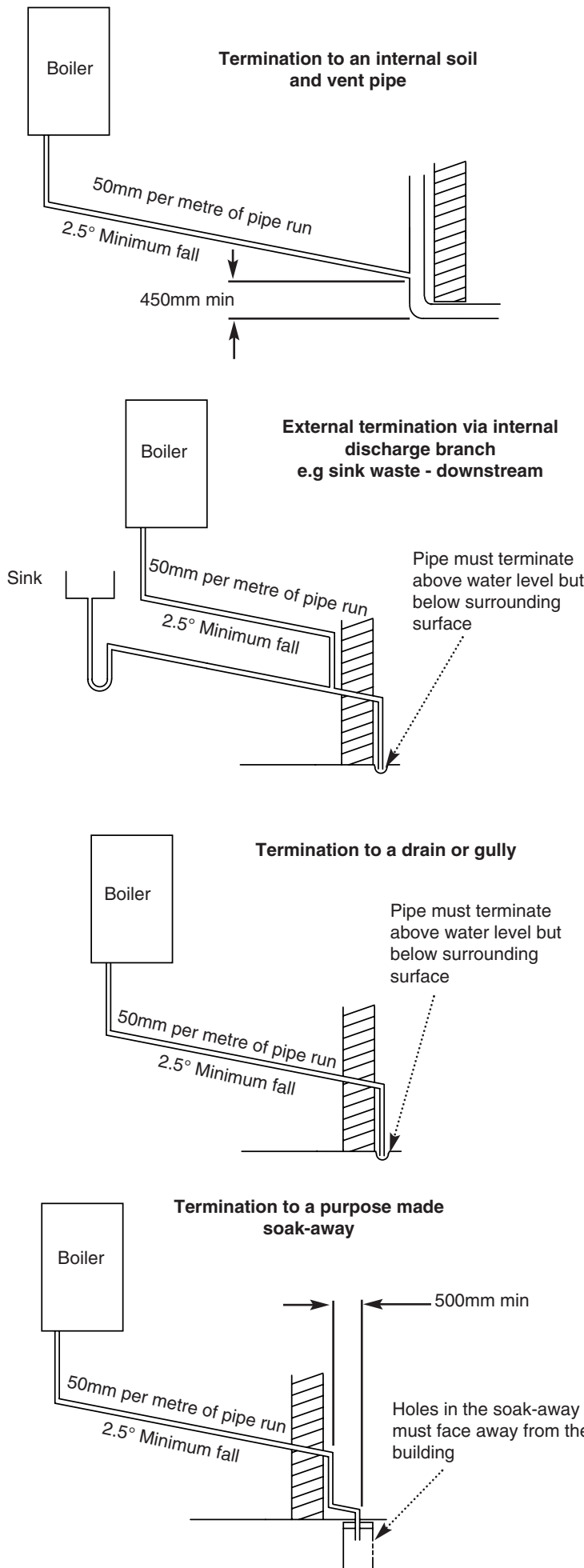

1. The condensate outlet will accept 21.5mm ( $\frac{3}{4}$ in) plastic overflow pipe which should generally discharge internally into the household drainage system. If this is not possible, discharge into an outside drain is acceptable.

2. Ensure the discharge of condensate complies with any national or local regulations in force.

**BS 6798:2000 & Part H1 of the Building Regulations give further guidance.**

3. The discharge pipe should be run in a proprietary drain pipe material e.g. PVC, PVC-U, ABS, PVC-C or PP.

4. Metal pipework is NOT suitable for use in condensate discharge systems.

5. The pipe should be a minimum of 21.5mm diameter and must be supported using suitably spaced clips to prevent sagging.

6. **Any pipe fitted externally must not exceed 3 metres.**

7. **Any condensate discharge pipework external to the building (or in an unheated part of it e.g. garage) must be insulated to protect against frost. It is also recommended that the pipe diameter is increased to 32mm.**

8. If the boiler is fitted in an unheated location the entire condensate discharge pipe should be treated as an external run.

9. In all cases discharge pipe must be installed to aid disposal of the condensate. To reduce the risk of condensate being trapped, as few bends and fittings as possible should be used.

10. When discharging condensate into a soil stack or waste pipe the effects of existing plumbing must be considered. If soil pipes or waste pipes are subjected to internal pressure fluctuations when WC's are flushed or sinks emptied then back-pressure may force water out of the boiler trap and cause appliance lockout.

Examples are shown of the following methods of termination:-

- i) to an internal soil & vent pipe
- ii) via an internal discharge branch (e.g. sink waste)
- iii) to a drain or gully
- iv) to a purpose made soakaway

## 7.0 SITE REQUIREMENTS

### 7.7 Flue

**NOTE:** Due to the nature of the boiler a plume of water vapour will be discharged from the flue. This should be taken into account when siting the flue terminal.

1. The following guidelines indicate the general requirements for siting balanced flue terminals. For GB recommendations are given in BS 5440 Pt 1. For IE recommendations are given in the current edition of I.S. 813 "Domestic Gas Installations".
2. If the terminal discharges onto a pathway or passageway, check that combustion products will not cause a nuisance and that the terminal will not obstruct the passageway.
3. If a terminal is less than 2 metres above a balcony, above ground or above a flat roof to which people have access, then a suitable terminal guard must be provided.

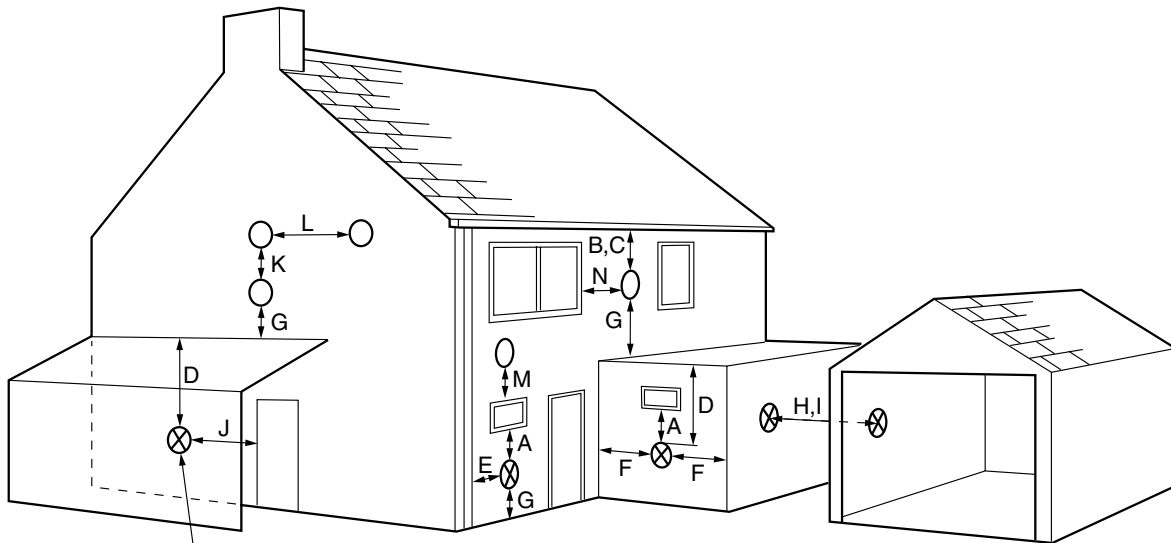
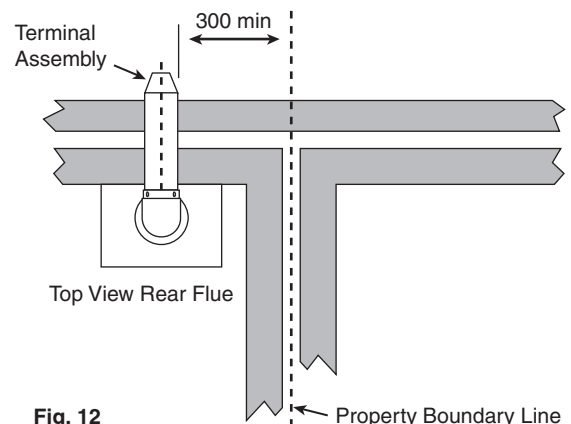

**Fig. 11** Likely flue positions requiring a flue terminal guard

**Terminal Position with Minimum Distance (Fig. 11) (mm)**

A*	Directly below an openable window, air vent or any other ventilation opening.	300
B	Below gutter, drain/soil pipe.	25
C	Below eaves.	25
D	Below a balcony/car port roof.	25
E	From vertical drain pipes and soil pipes.	25
F	From internal or external corners.	25
G	Above adjacent ground or balcony level.	300
H	From a surface facing a terminal.	600
I	Facing a terminals.	1200
J	From opening (door/window) in carport into dwelling.	1200
K	Vertically from a terminal on the same wall.	1500
L	Horizontally from a terminal on the same wall.	300
M*	Above an opening, air brick, opening window etc.	300
N*	Horizontally to an opening, air brick, opening window etc.	300

\* In addition, the terminal should be no nearer than 150mm to an opening in the building fabric formed for the purpose of accommodating a built-in element such as a window frame. See BS 5440 Pt. 1.



**Fig. 12**

## 7.0 SITE REQUIREMENTS

### 7.8 Flue Dimensions

The standard horizontal flue kit allows for flue lengths between 100mm and 685mm from elbow to terminal (Fig. 13).

**The maximum permissible equivalent flue length is: 10 metres**

### 7.9 Flue Trim

1. The rubber flue trim supplied may be fitted to either the outside wall or on the inner wall of installation.

### 7.10 Terminal Guard (Fig. 14)

1. When codes of practice dictate the use of terminal guards, they can be obtained from most Plumbers' and Builders' Merchants.

2. There must be a clearance of at least 50mm between any part of the terminal and the guard.

3. When ordering a terminal guard, quote the appliance name and model number.

4. The flue terminal guard should be positioned centrally over the terminal and fixed as illustrated.

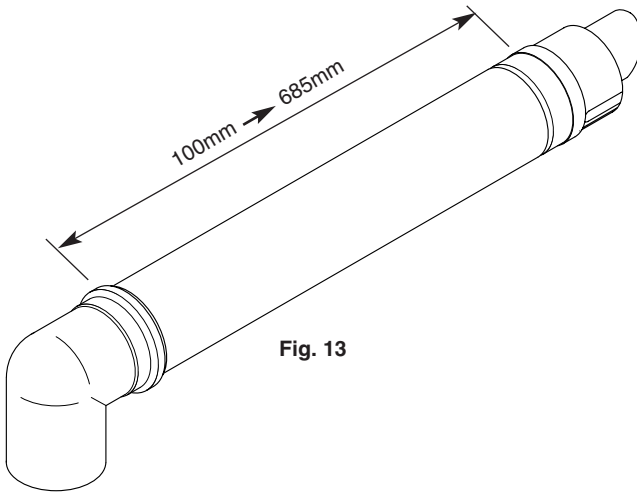

Fig. 13

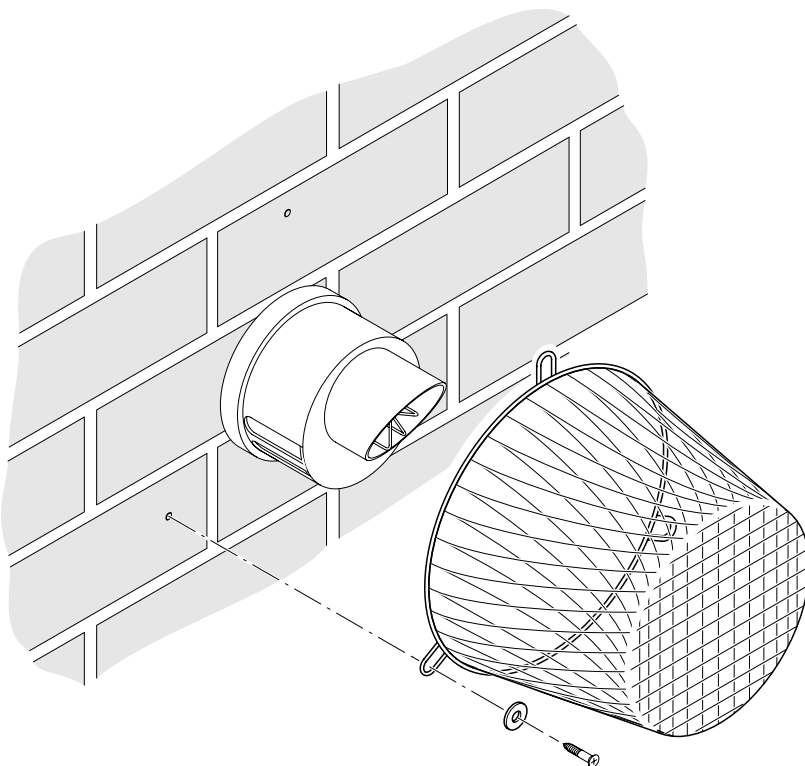

Fig. 14

## 7.0 SITE REQUIREMENTS



### 7.11 Flue Options

1. The Potterton Gold HE can be fitted with flue systems as illustrated.
2. The standard flue is suitable only for horizontal termination applications.
3. Maximum permissible equivalent flue lengths are:-

Horizontal Concentric	10 metres
Vertical Concentric	10 metres
Vertical Twin Pipe	15 metres

4. Any additional "in line" bends in the flue system must be taken into consideration.

Their equivalent lengths are:-

Concentric Pipes:

45° bend	0.5 metres
93° bend	1.0 metres

Twin Flue Pipe

45° bend	0.25 metres
91.5° bend	0.50 metres

The elbow supplied with the boiler is not included in any equivalent length calculations

5. The illustrations opposite show examples of permissible flue systems.

6. Instructions for guidance and fitting are included in each kit, where appropriate.

**NOTE:** Flue length is measured from point A to B as shown.

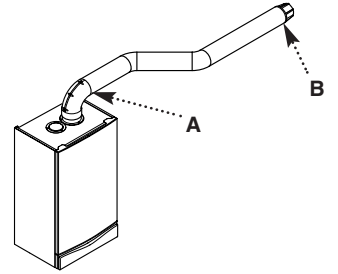
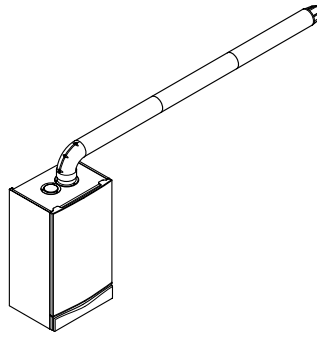

**Horizontal Flues**

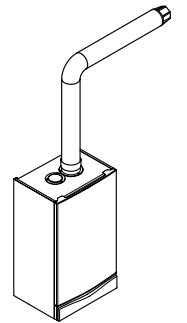
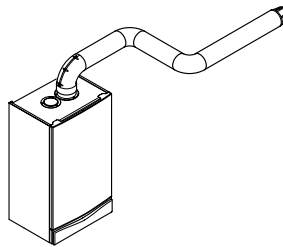

**Vertical Flues (Twin Pipe)**

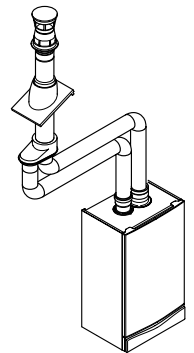
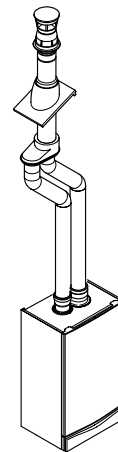
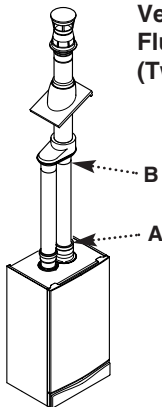

**Vertical Flues**

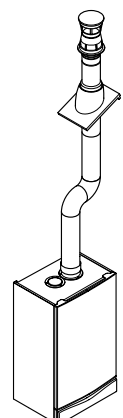
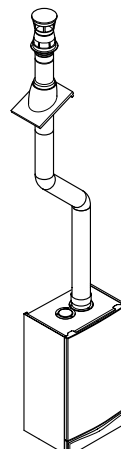
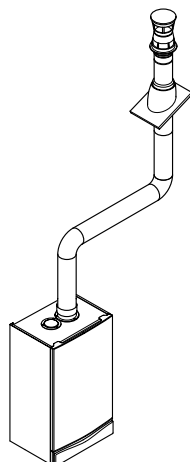
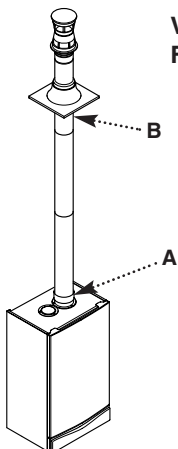

## 8.0 INSTALLATION

### 8.1 Initial Preparation

The gas supply, gas type and pressure must be checked for suitability before connection (see Section 7.4).

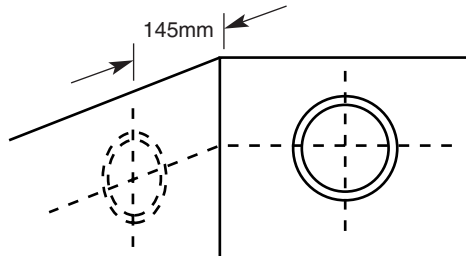

For Side Flue Exit

Fig. 16

1. After considering the site requirements (see Section 7.0) position the fixing template on the wall ensuring it is level both horizontally and vertically.
2. Mark the position of the two most suitable fixing slots for the wall plate and boiler lower fixing holes. It is preferable to use the horizontal fixing slots.
3. Mark the position of the centre of the flue hole (rear exit). For side flue exit, mark as shown (Fig. 16).
4. Note the shaded area on the template. Pipework may be routed upwards behind the boiler, providing it does not conflict with the shaded area.
5. If required, mark the position of the gas and water pipes. Remove the template.
6. Cut the hole for the flue (minimum diameter 116mm).
7. Drill the wall as previously marked to accept the wall plugs supplied. Secure the wall plate using the fixing screws.
8. Using a spirit level ensure that the plate is level before finally tightening the screws.
9. Connect the gas and water pipes to the valves on the wall plate using the copper tails supplied. Ensure that the sealing washers are fitted between the connections.

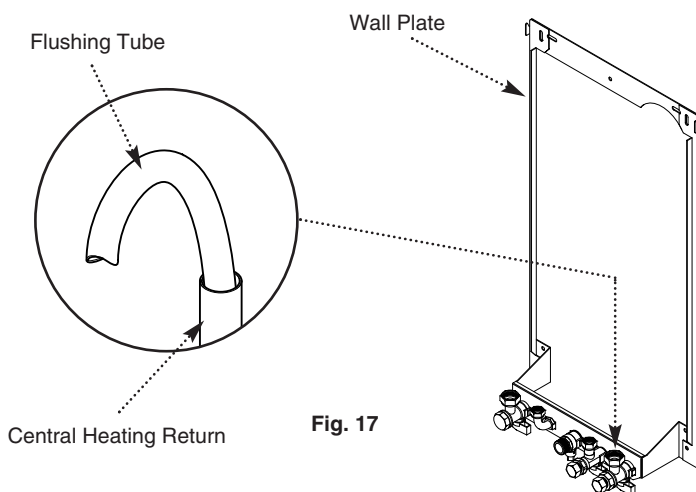

Fig. 17

### 8.2 Flushing

1. Connect a tube to the central heating flow or return pipe (Fig. 17).
2. Flush thoroughly (see System Details, Section 6.2).

### 8.3 Preparing The Boiler

1. Remove all packaging.
2. Stand the boiler on its base by using the rear lower edge as a pivot.

**NOTE:** A small amount of water may drain from the boiler in the upright position.

## 8.0 INSTALLATION

### 8.4 Fitting the Filling Loop

1. The filling loop supplied with the boiler can be connected to the taps on the wall plate at this point.
2. The filling loop is to be connected between the mains cold water inlet and central heating return isolation taps.
3. The loop and valves must be connected as shown in the diagram (Fig. 17a).
4. The two flanged copper elbows supplied are of different lengths (Fig. 17b). Use pipe 'A' to connect to the cold inlet. Pipe 'B' should be used to connect to the central heating return.
5. Note the orientation of the flow direction arrows on the stop valve and double check valve.
6. Ensure the brass flange nuts are on each pipe and connect the plain end of pipe 'A' to the stop valve inlet and the plain end of pipe 'B' to the outlet of the check valve using the nuts and washers supplied.
7. Remove the end caps from the isolation taps and put to one side. Engage the brass flange nuts to the appropriate connections on the tap rail or pipework. Ensure that the fibre washers supplied are used on these joints.

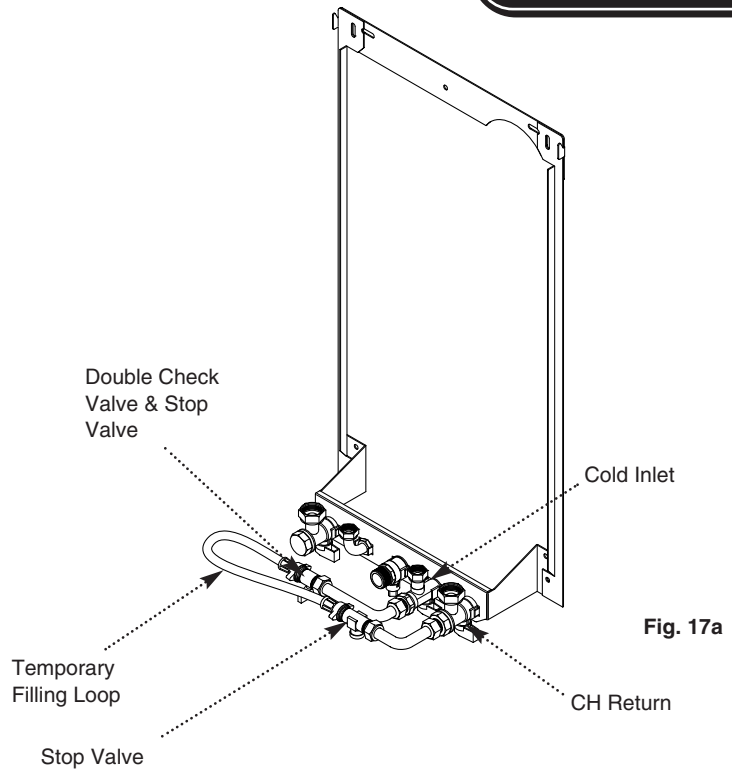

Fig. 17a

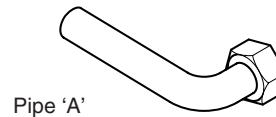
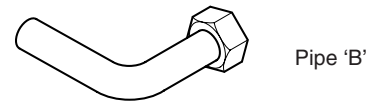

Fig. 17b



Pipe 'B'

To fill, test and flush if required (Fig. 17c)

8. Take the blanking plugs from the kit, and using washers supplied with the boiler, connect them to the central heating flow and return taps, and the cold inlet tap. The system can now be filled by opening the cold inlet supply and stop valve.
9. If desired a suitable gauge can be connected to one of the taps so that the system may be accurately pressurised.
10. All joints, fittings and system components can now be examined for soundness at operating pressure.
11. The system can be flushed by turning off the central heating tap and connecting a suitable fitting to the loose nut. From the fitting a hose pipe can be run to the nearest convenient drain. When the tap is reopened the system will flush.
12. Remove the blanking plug(s), pressure gauge and flushing equipment from the appliance if used.
13. Continue with the installation and commissioning.
14. The filling loop must be disconnected and completely removed after the system is pressurised.
15. Hand tighten the two previously removed end caps to the stop valve and double check valve.

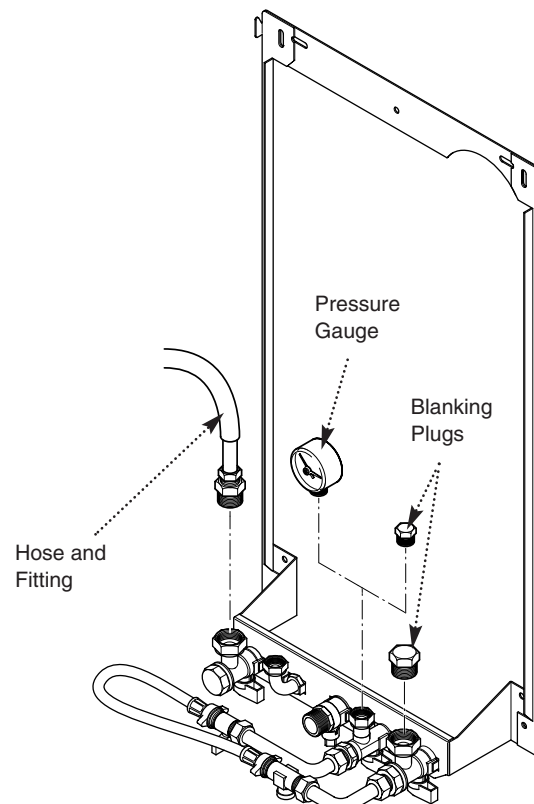

Fig. 17c

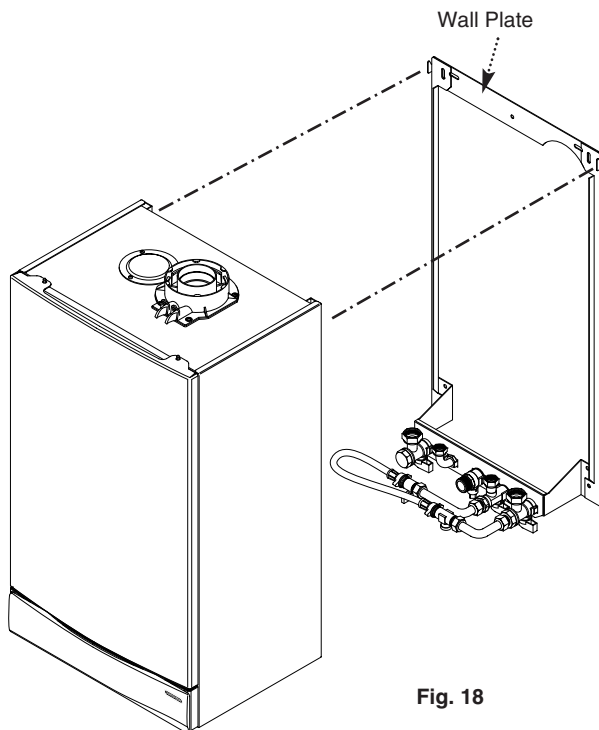

Fig. 18

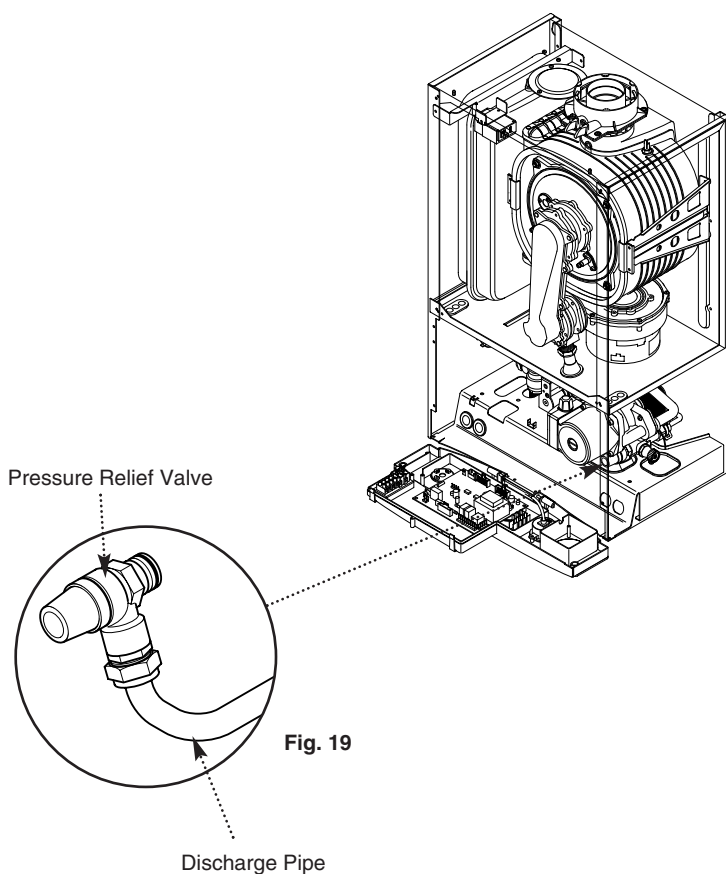

Fig. 19

## 8.0 INSTALLATION

### 8.5 Fitting The Boiler

1. Remove the sealing caps from the boiler connections.
2. Lift the boiler using the lower edges. Engage the slots at the top rear of the boiler on the wall plate (Fig. 18).
3. Insert the sealing washers between the valves and pipes on the wall plate and the boiler connections. **The rubber washers must be used on the gas connection.**
4. Tighten all the connections.

### 8.6 Fitting the Pressure Relief Discharge Pipe (Fig. 19)

1. Remove the discharge pipe from the kit.
2. Determine the routing of the discharge pipe in the vicinity of the boiler. Make up as much of the pipework as is practical, including the discharge pipe supplied.
3. The pipework must be at least 15mm diameter and run continuously downwards to a discharge point outside the building. See section 6.7 for further details.
4. Utilising one of the sealing washers, connect the discharge pipe to the adaptor and tighten the nut.
5. Complete the discharge pipework and route it to the outside discharge point.

**IMPORTANT:** Make all soldered joints before connecting to the pressure relief valve.

### 8.7 Condensate Drain (see section 7.6)

1. Connect the condensate drain to the trap outlet pipe.

Ensure the discharge of condensate complies with any national or local regulations in force (see British Gas "Guidance Notes for the Installation of Domestic Gas Condensing Boilers").

2. The connection will accept 21.5mm (<sup>3</sup>/<sub>4</sub>in) plastic overflow pipe which should generally discharge internally into the household drainage system. If this is not possible, discharge into an outside drain is acceptable.



## 8.0 INSTALLATION



### 8.8 Fitting The Flue

#### HORIZONTAL FLUE

1. The standard flue is suitable for lengths between 100mm minimum and 685mm maximum, as measured from the edge of the flue elbow outlet to the joint between the terminal and air duct (Fig. 20).

2. Locate the flue elbow on the adaptor at the top of the boiler. Set the elbow to the required orientation (Fig. 21).

**NOTE:** The flue elbow is angled at 93 degrees to ensure a fall back to the boiler.

3. Measure the distance from the outside wall face to the elbow. This dimension will be known as 'X' (Fig. 22).

4. To dimension 'X' add 50mm. This dimension to be known as 'Y'.

**IMPORTANT:** Check all dimensions before cutting.

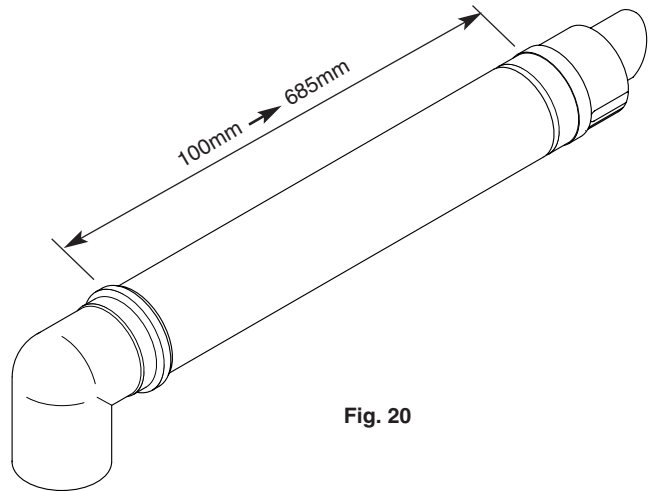

Fig. 20

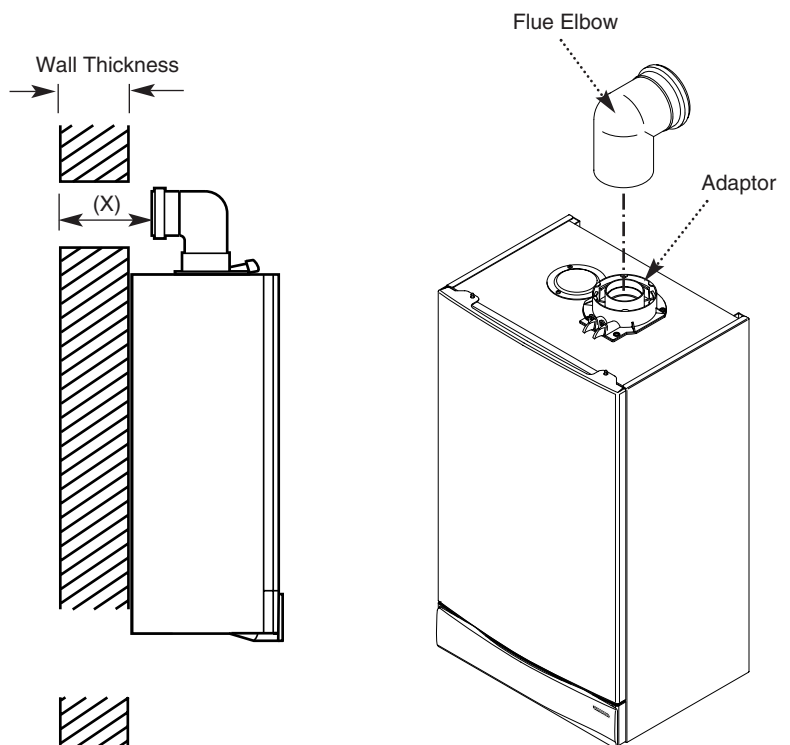

Fig. 21

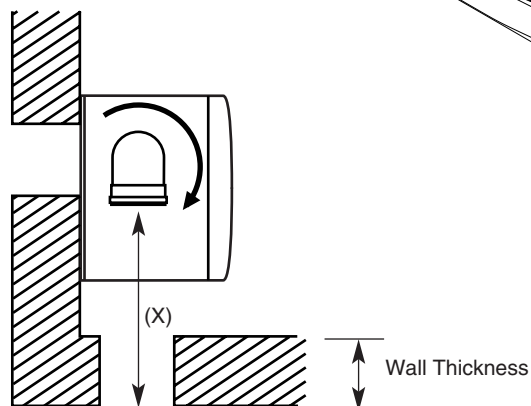

Fig. 22

## 8.0 INSTALLATION

### 8.8 Fitting the Flue (Cont)

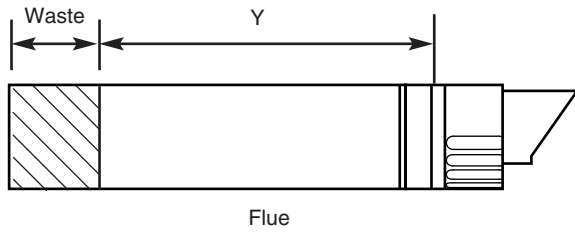

Fig. 23

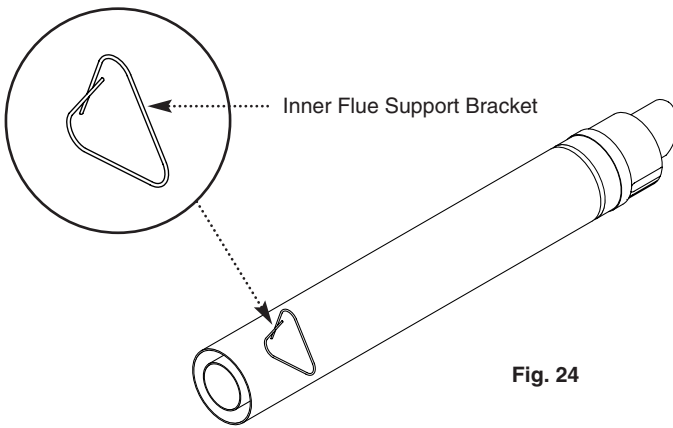

Fig. 24

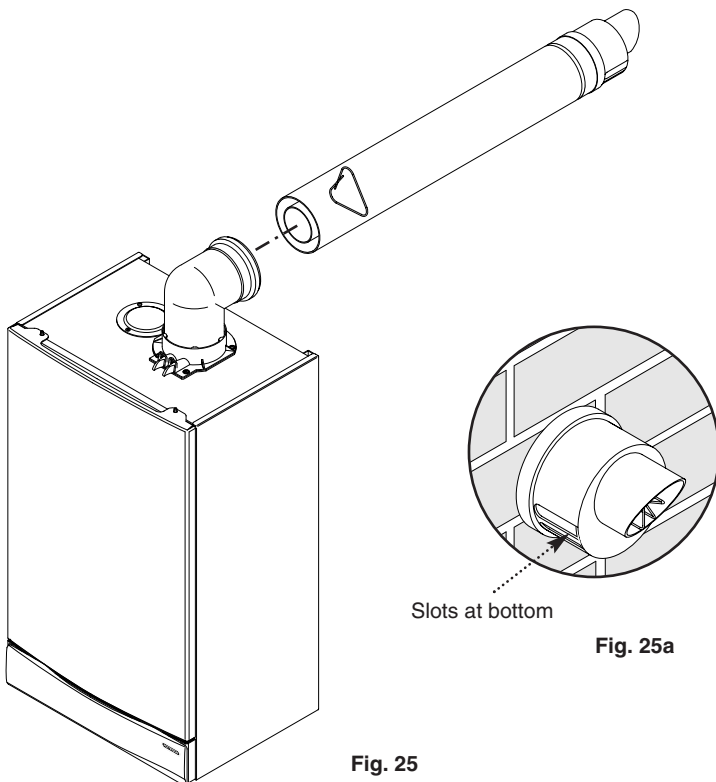

Fig. 25a

Fig. 25

5. Mark dimension 'Y' on the flue as shown (Fig. 23). Carefully cut the waste material from the flue, ensuring that the ducts are square and free from burrs.

6. The inner flue duct support bracket may be in the waste portion of the flue. In this case retrieve the bracket before discarding the waste.

7. Take the inner flue support bracket (if not already fitted) and engage it over the flue duct. This will centralise the flue and air ducts, and ease assembly (Fig. 24).

8. Remove the flue elbow and insert the flue through the hole in the wall. Refit the elbow to the boiler adaptor, ensuring that it is pushed fully in.

9. Draw the flue back through the wall and engage it in the elbow. It may be necessary to use soap solution or similar to ease assembly of the elbow adaptor and flue (Fig. 25).

10. Ensure that the terminal is positioned with the slots to the bottom (Fig. 25a).

**IMPORTANT:** It is essential that the flue terminal is fitted as shown to ensure correct boiler operation and prevent water entering the flue.

11. Make good between the wall and air duct outside the building.

12. Fit the flue trim if required, and if necessary fit a terminal guard (see Section 7.9 & 7.10).

## 8.0 INSTALLATION



### 8.9 Making The Electrical Connections

To connect the mains input cable proceed as follows:-

1. Slacken the facia panel securing screws and lift the outercase panel so that its securing tabs are clear of the facia. Remove the panel.
2. Completely undo the screws securing the facia panel and hinge it down (Fig. 26).
3. Remove the control box cover securing screws. Disengage the barbs on the control box from the cover. Remove the cover (Fig. 27).
4. Slacken the cable clamp on the LH side of the boiler chassis (Fig. 28). Insert the cable through the clamp and route it to the terminal block.
5. Slacken the screws in the terminal block, connect the input cable, and tighten the screws.

**NOTE:** Both the Live and Neutral connections are fused.

6. The boiler is fitted with an integral timer. If a room thermostat is to be connected it can be done at this point. Run the input cable from the thermostat through the second cable clamp on the boiler chassis. Refer to the instructions supplied with the control.

**IMPORTANT:** The room thermostat **MUST** be suitable for 230V switching.

**NOTE:** An external frost thermostat cannot be used with the integral timer.

7. Remove the link between terminals 1 & 2. The 230V supply at terminal 1 can be connected to the thermostat. The switched output from the thermostat must be connected to terminal 2. (Fig. 29). If the room thermostat being used incorporates an anticipator it **MUST** be wired as shown in Fig. 29.

8. Ensure that both mains input and, where fitted, external control input cables have sufficient slack to allow the control box to drop down. Tighten the cable clamp(s) on the boiler chassis.

### 8.10 Preliminary Electrical Checks

1. Prior to commissioning the boiler preliminary electrical system checks should be carried out.
2. These should be performed using a suitable meter, and include checks for Earth Continuity, Resistance to Earth, Short Circuit and Polarity.

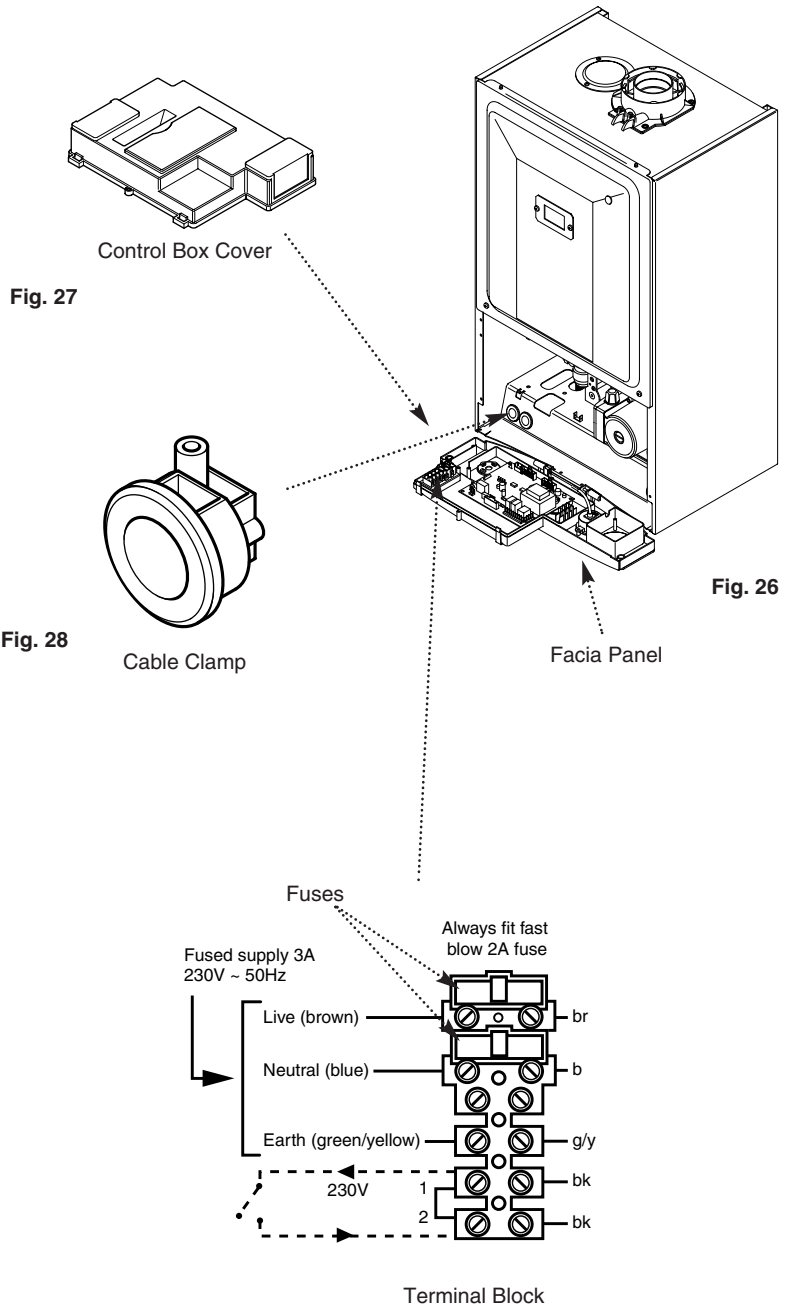
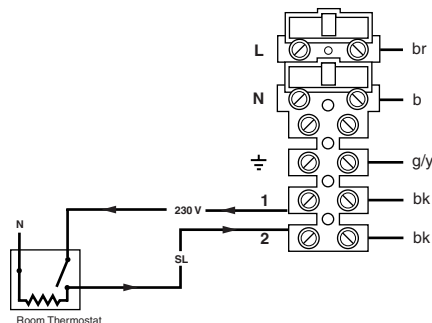

Fig. 29



## 9.0 COMMISSIONING

### 9.1 Commissioning the Boiler

1. Reference should be made to BS 5449 Section 5 when commissioning the boiler.
2. Open the mains water supply to the boiler.
3. Open all hot water taps to purge the DHW system.
4. Ensure that the filling loop is connected and open, then open the heating flow and return valves on the boiler.
5. Open the screw on the automatic air vent (Fig. 30).
6. The system must be flushed in accordance with BS 7593 (see Section 6.2) and the flushing agent manufacturers instructions.
7. Pressurise the system to 1.5 bar then close and disconnect the filling loop.
8. Turn the gas supply on and purge according to in GB BS 6891 and in IE I.S. 813 "Domestic Gas Installations".
9. Test for gas soundness.
10. Hinge the facia panel upwards and refit the case front panel. Tighten the securing screws.
11. Turning either of the temperature control knobs will set the relevant temperature. When the knob is turned the display will alter and show the selected temperature. After a few seconds the display reverts to show the current boiler temperature (Fig. 32).

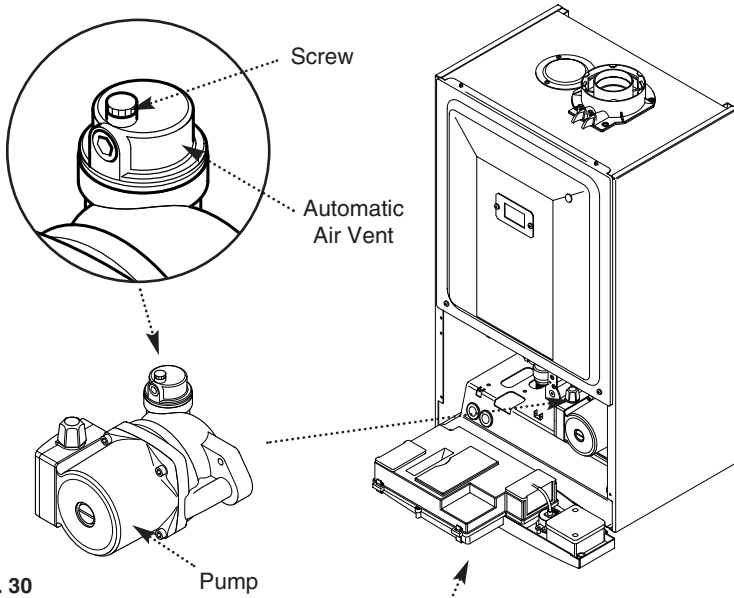

Fig. 30

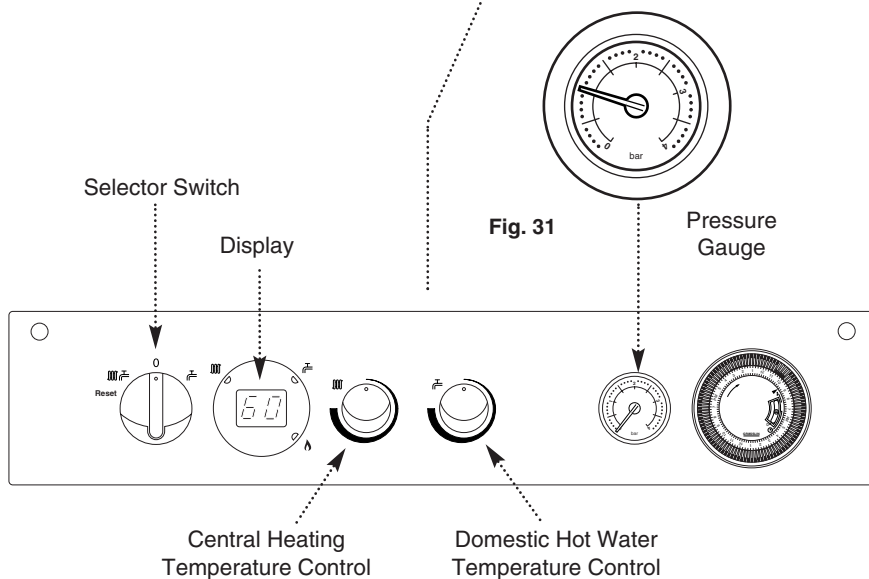

Fig. 32

## 9.0 COMMISSIONING

### 9.2 Setting the Timer

The Electro-Mechanical Timer allows the central heating system to be set every 15 minutes.

Using the three position switch the timer will allow either constant operation, timed operation or central heating off.

Move the switch button by sliding to the desired position.

#### Three position switch (Fig. 32a)

**I Constant (Top position):** The heating will be on constantly irrespective of the position of the tappets. The heating will be controlled by the main thermostat on the appliance and/or any external controls.

**⌚ Timed (Central position):** The heating will operate according to the position of the tappets and be controlled as above.

**0 Off (Bottom position):** No central heating. Domestic hot water will operate on demand.

#### To set the time of day

Turn the timer outer bezel clockwise, to align the pointer with the correct time to the nearest 15 minutes ensuring that A.M./P.M. is considered. **Do not at any time attempt to turn the bezel anti-clockwise.**

#### To set the timed heating program

Decide which times of the day the central heating is required.

The heating will operate when the white tappets are set to the outer edge of the bezel.

To ensure the heating stays OFF set the required tappets inwards towards the centre of the bezel.

Each tappet represents 15 minutes.

For example: If the heating is not required between 10 A.M. and 11 A.M. the four tappets anticlockwise from the 10 A.M. will be set inwards (Fig. 32b).

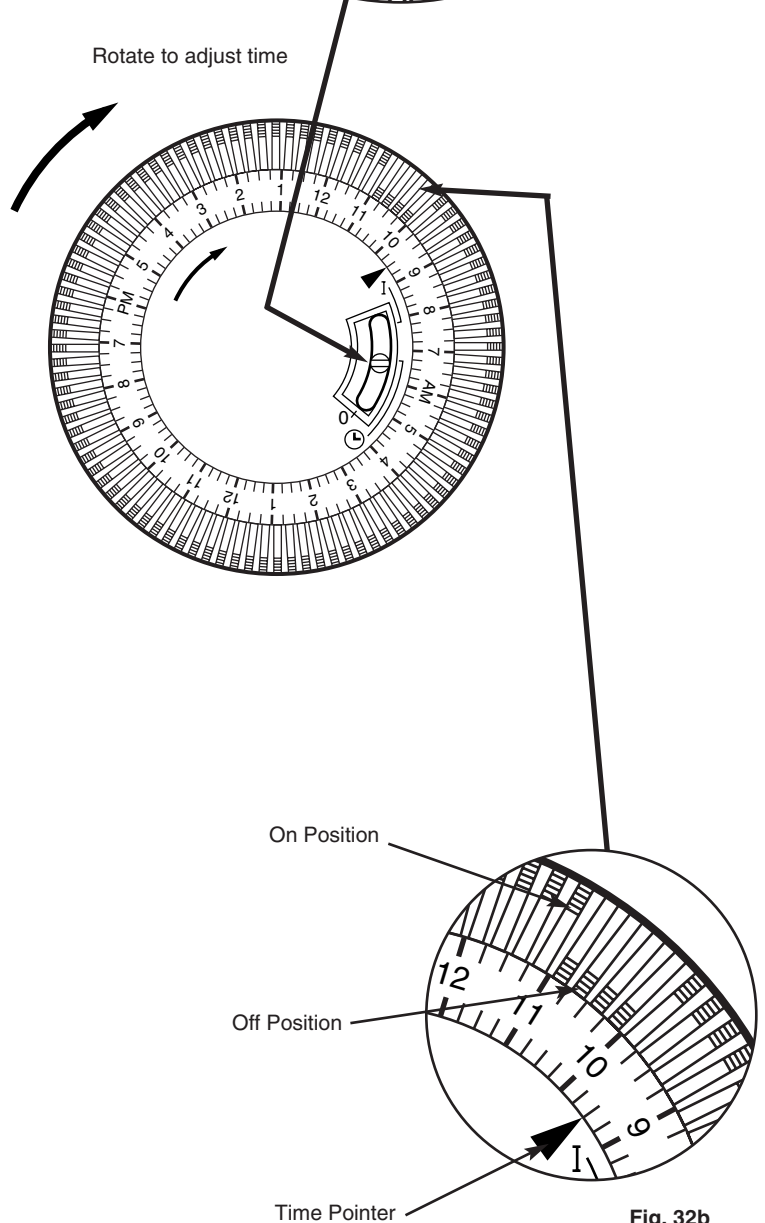
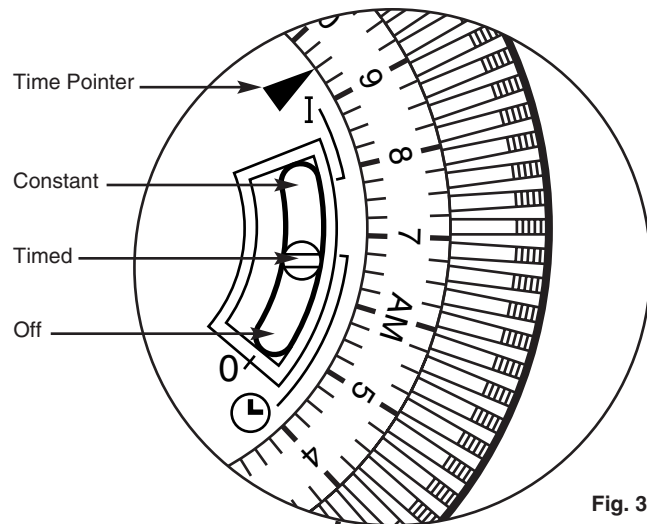

## 9.0 COMMISSIONING

### 9.3 Checking

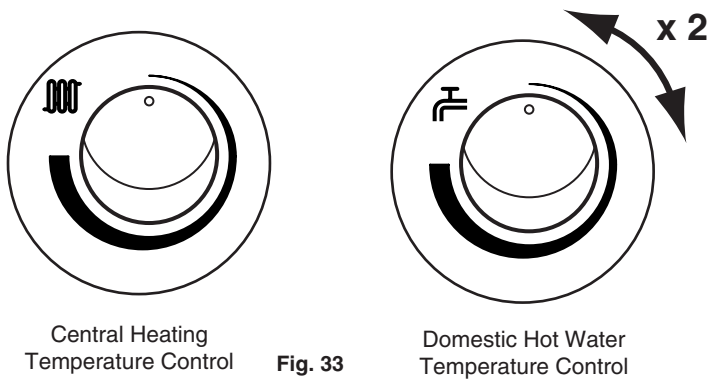

Fig. 33

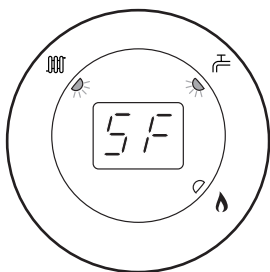
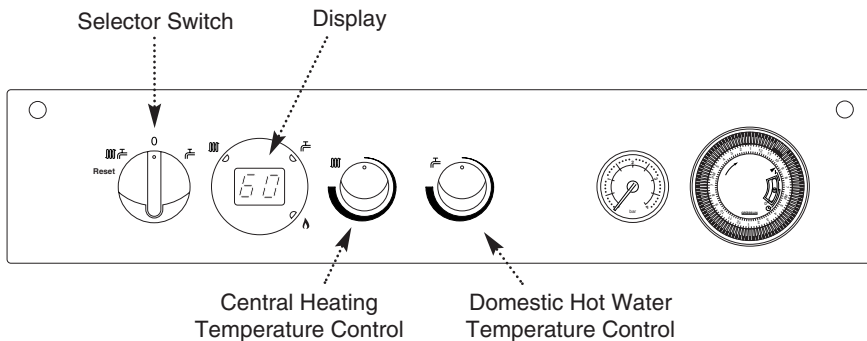

Fig. 34

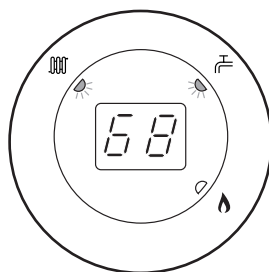

Fig. 35

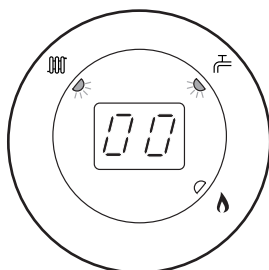

Fig. 36

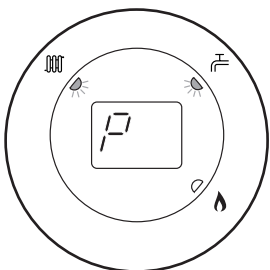

Fig. 37

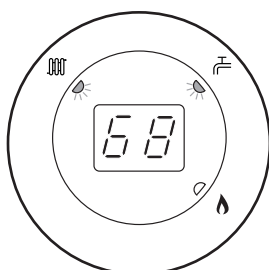

Fig. 38

1. The gas valve is factory set and the burner pressure cannot be measured as it is altered by suction of the fan and modulates as demand on the boiler alters. The gas supply pressure should be 20mb.

2. If necessary the gas rate may be checked after running the boiler for 10 minutes with any other appliances and pilot lights turned off.

3. Ensure that the integral timer and any external controls are calling for heat, and the selector switch is in the central heating and hot water position (SF). The current boiler temperature is shown on the display.

4. To check the gas rate it is necessary to set the boiler to 'Calibration Mode'.

5. Turn both temperature control knobs fully anticlockwise, then quickly turn the DHW temperature knob 1/4 clockwise twice and back fully anticlockwise (Fig. 33).

6. The display will now alternate between 'SF' and the current boiler temperature and both green LEDs will flash (Figs. 34 & 35).

7. Turn CH temperature control knob fully clockwise. As the knob is turned the display will change from '0' to '00' (Fig. 36) indicating maximum rate, then revert to 'P' alternating with the current boiler temperature (Figs 37 & 38).

8. A gas rate measurement may now be made. Approximate values are:-

24 model - 2.6 m<sup>3</sup>/h

28 model - 3.1 m<sup>3</sup>/h

33 model - 3.6 m<sup>3</sup>/h

9. The 'Calibration Function' is active for 20 minutes unless the maximum CH temperature is exceeded.

10. The function can be disabled at any time by turning the DHW temperature knob.

## 10.0 COMPLETION



### 10.1 Completion

1. Instruct the user in the operation of the boiler and system including the integral timer, explaining the operational sequence.
2. Set the central heating and hot water temperature control knobs to the requirements of the user.
3. Carefully read and complete all sections of the Benchmark Commissioning Checklist at the rear of this publication that are relevant to the appliance and installation. These details will be required in the event of any warranty work. The publication must be handed to the user for safe keeping and each subsequent regular service visit recorded.
4. For IE, it is necessary to complete a "Declaration of Conformity" to indicate compliance with I.S. 813. An example of this is given in I.S. 813 "Domestic Gas Installations". This is in addition to the Benchmark Commissioning Checklist.
5. Hand over the Users Operating, Installation and Servicing Instructions giving advice on the necessity of regular servicing.

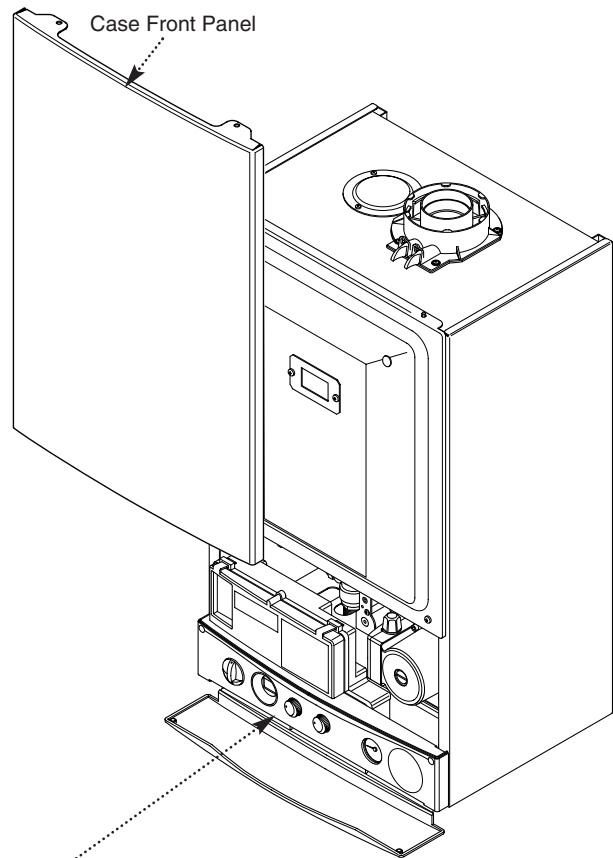

Facia Panel

Fig. 39

## 11.0 SERVICING

### 11.1 Annual Servicing

1. For reasons of safety and economy, it is recommended that the boiler is serviced annually. Servicing must be performed by a competent person.

If a combustion analyser is available the CO<sub>2</sub> can be checked and adjusted - see Section 13.0.

2. After servicing, complete the relevant Service Interval Record section of the Benchmark Commissioning Checklist at the rear of this publication.

3. Ensure that the boiler is cool.

**4. Ensure that both the gas and electrical supplies to the boiler are isolated.**

5. Slacken the screws securing the fascia panel. Lift the outercase panel so that its securing tabs are clear of the fascia. Remove the panel, allowing the fascia to hinge down (Fig. 40).

6. Remove the screws securing the inner door panel. Lift the panel slightly to disengage it from the studs on top of the case (Fig. 41).

7. Unscrew the sump from the bottom of the condensate trap assembly (Fig. 41a).

8. Remove any deposits from the sump and trap. Clean as necessary and replace the sump.

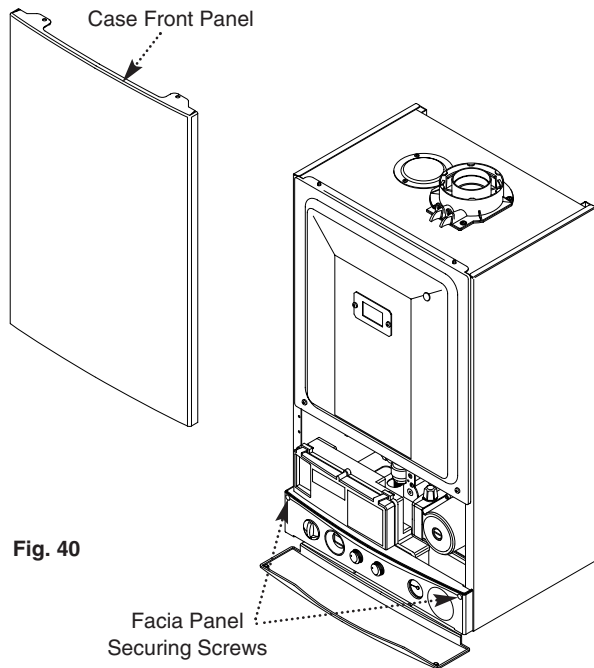

Fig. 40

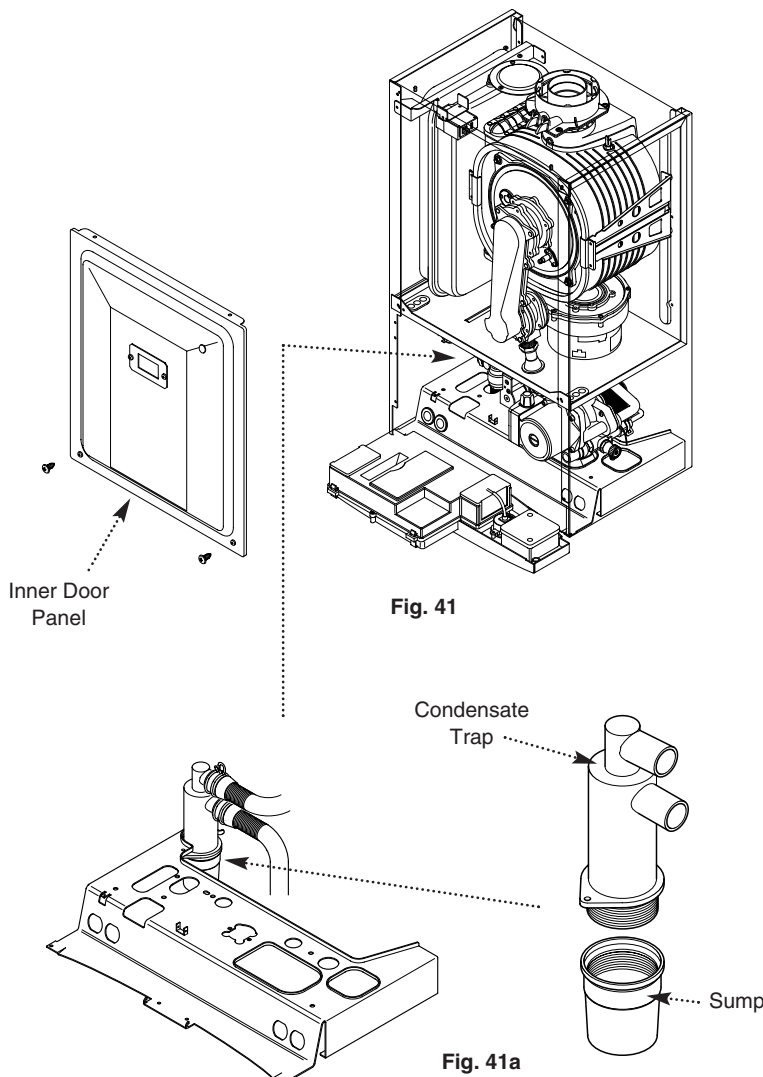

Fig. 41

Fig. 41a



## 11.0 SERVICING

**POTTERTON**

### 11.1 Annual Servicing (Cont)

7. Undo the nut on the gas inlet pipe to the venturi (Fig. 42) and pull the sensing pipe off the fan.

8. Disconnect the electrode leads, noting their position, and the fan electrical plugs (Fig. 43).

9. Undo the four nuts retaining the combustion box cover to the heat exchanger.

10. Carefully draw the fan, collector and cover assembly forward, being careful to retain the injector in the venturi (Figs. 42 & 43).

11. Clean any debris from the heat exchanger and check that the gaps between the tubes are clear.

12. Inspect the burner, electrodes position and insulation, cleaning or replacing if necessary. Clean any dirt or dust from the air box.

13. Reassemble in reverse order.

**NOTE:** The sensing pipe must be reconnected to the fan, not the venturi.

### DHW Filter (Fig. 45)

14. If the flow of domestic hot water is diminished, it may be necessary to clean the filter.

15. Initially check the cold water inlet tap filter.

16. Turn the tap off and draw off from a hot tap. Undo the blanking cap and remove the threaded bush (Fig. 44).

17. Extract the filter and rinse thoroughly in clean water. Reassemble and check the flow. If required clean the restrictor filter as described below.

18. Pull off the hall effect sensor. Undo the restrictor from the inlet/return manifold.

19. Rinse the filter thoroughly in clean water and reassemble in reverse order.

20. Turn the selector switch fully anticlockwise against the spring pressure to the reset position and hold for 5 seconds to reset the boiler.

21. Complete the relevant Service Interval Record section of the Benchmark Commissioning Checklist at the rear of this publication and then hand it back to the user.

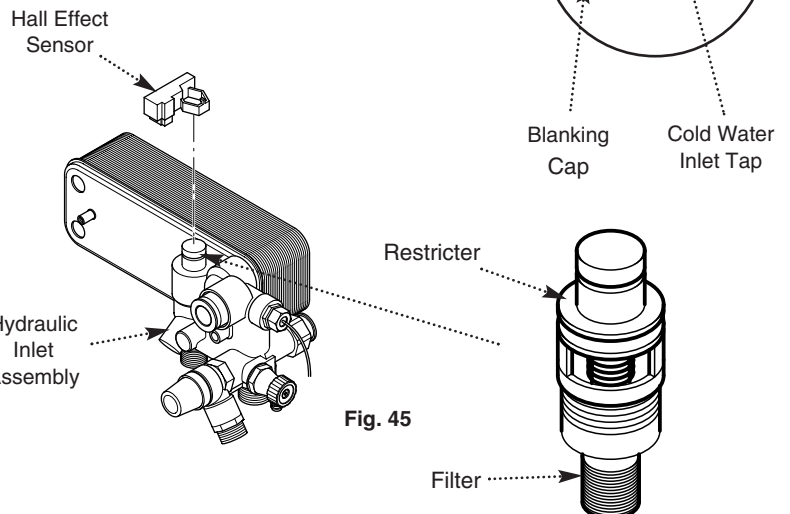
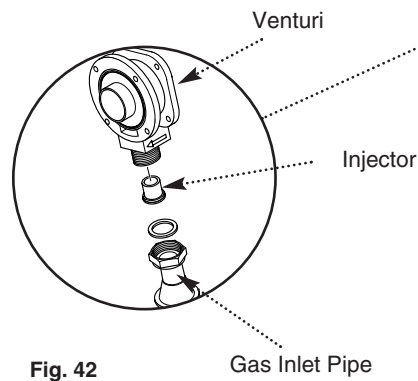
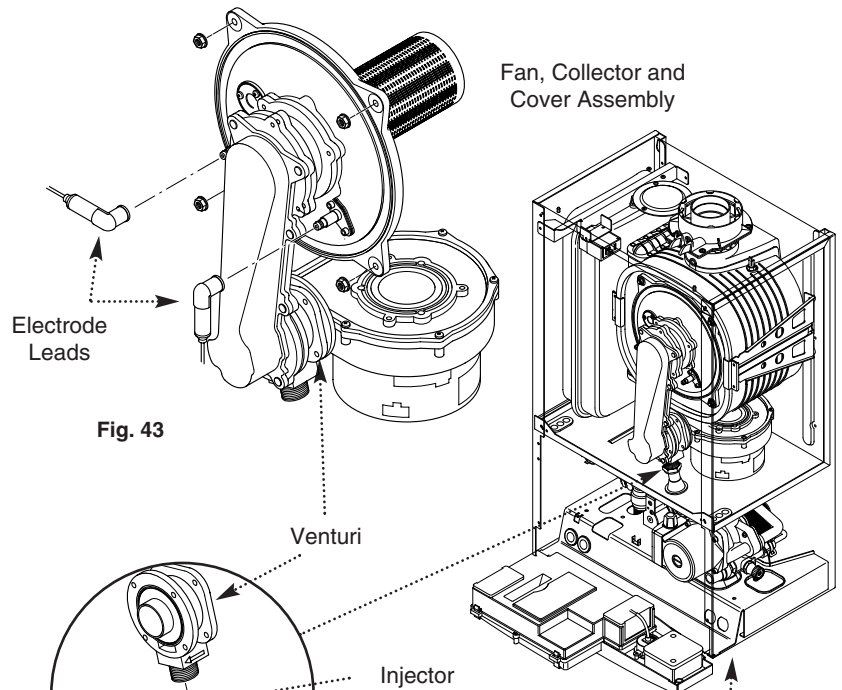
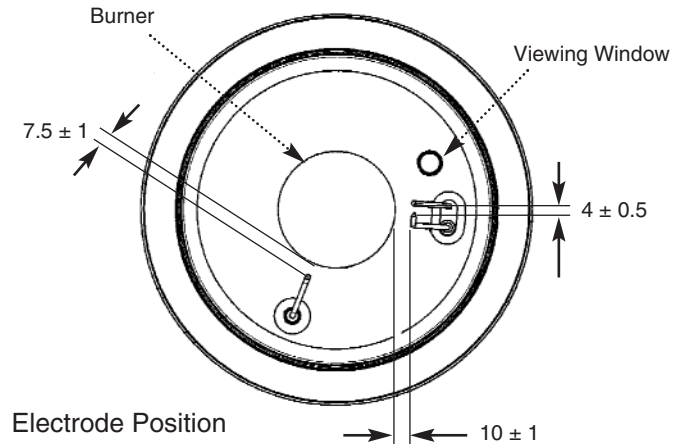

## 12.0 CHANGING COMPONENTS

**IMPORTANT:** When changing components ensure that both the gas and electrical supplies to the boiler are isolated before any work is started. When the component has been changed turn the selector switch fully anticlockwise against the spring pressure to the reset position and hold for 5 seconds to reset the boiler before recommissioning.

See Section 11.1 "Annual Servicing" for removal of case panel, door etc.

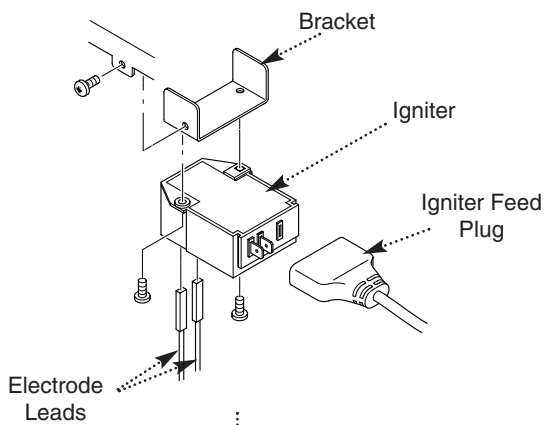
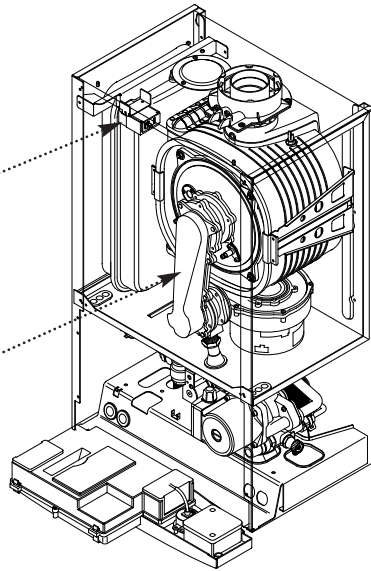

Fig. 46



### 12.1 Igniter (Fig. 46)

1. Disconnect the igniter feed plug and the electrode leads, noting their positions.
2. Undo the screw securing the bracket to the boiler.
3. Remove the igniter and transfer the bracket to the new component.
4. Reassemble in reverse order.

### 12.2 Spark and Sensing Electrodes (Fig. 47)

1. Disconnect the electrode leads, noting their positions.
2. Remove the retaining screws securing each of the electrodes to the combustion box cover and remove the electrodes.
3. Check the condition of the sealing gaskets and replace if necessary. Reassemble in reverse order.

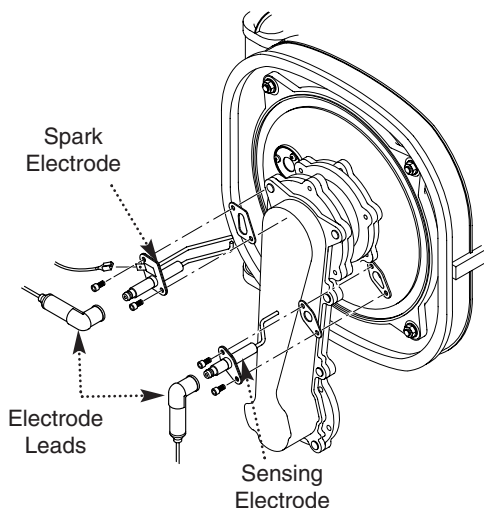

Fig. 47

## 12.0 CHANGING COMPONENTS

### 12.3 Fan (Fig. 48)

1. Undo the nut on the gas inlet pipe to the venturi (Fig. 49) and pull the sensing pipe off the fan.
2. Disconnect the electrode leads, noting their position and disconnect the fan electrical plugs.
3. Undo the screws securing the collector to the extension piece.
4. Remove the collector and fan assembly, being careful to retain the injector in the venturi.
5. Undo the screws securing the fan to the venturi and fit the new fan, replacing the seal if necessary.
6. Examine the burner gasket and replace if necessary.
7. Reassemble in reverse order, ensuring that the injector is in place and the sensing pipe is connected to the fan.

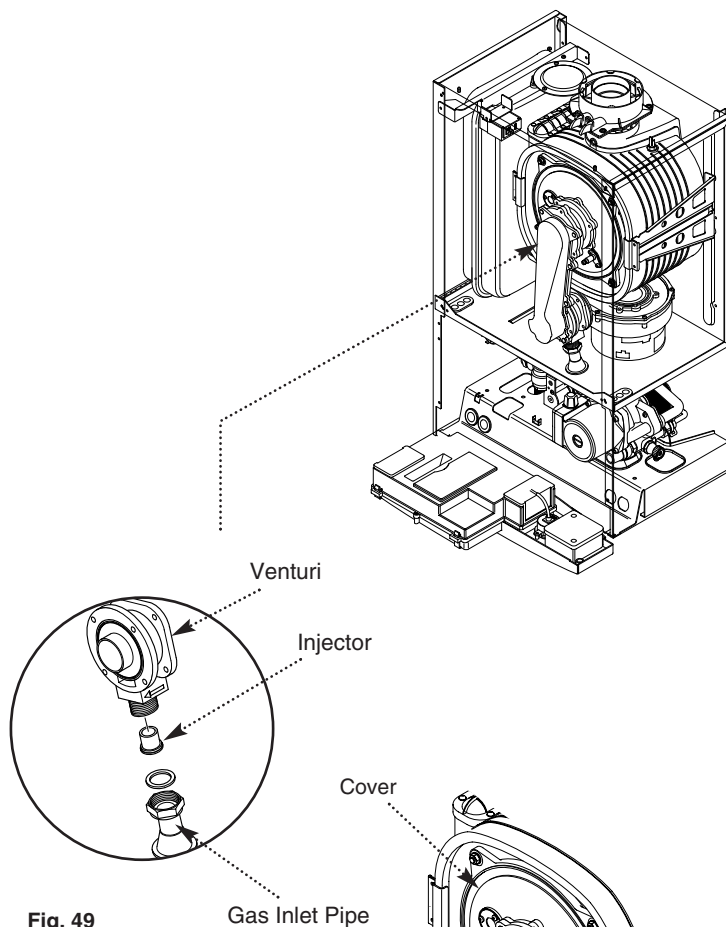

Fig. 49

### 12.4 Venturi (Fig. 48)

1. Remove the collector and fan assembly as described in section 12.3.
2. Extract the injector from the venturi.
3. Undo the screws securing the fan to the venturi and the venturi to the collector.

**IMPORTANT:** When fitting the new venturi, ensure the arrows on its base point into the collector (Fig. 50).

4. Examine the seals and burner gasket, replace if necessary.
5. Reassemble in reverse order, ensuring that the injector is in place.

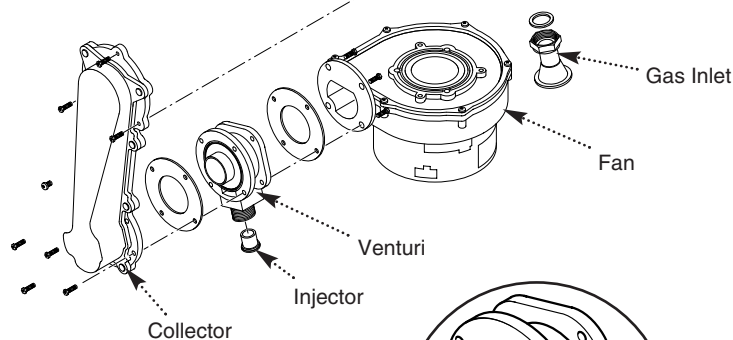

Fig. 48

### 12.5 Injector (Fig. 48)

1. Remove the collector and fan assembly as described in section 12.3.
2. Extract and replace the injector and reassemble in reverse order.

Fig. 50

When fitting the venturi ensure that the arrow is pointing forward

## 12.0 CHANGING COMPONENTS

### 12.6 Burner (Fig. 51)

1. Undo the screws securing the collector to the venturi and extension piece. Remove this extension piece from the cover (on 24 and 28 models).
2. Withdraw the burner from the cover and replace with the new one.
3. Examine the gasket, replacing if necessary.
4. Reassemble in reverse order.

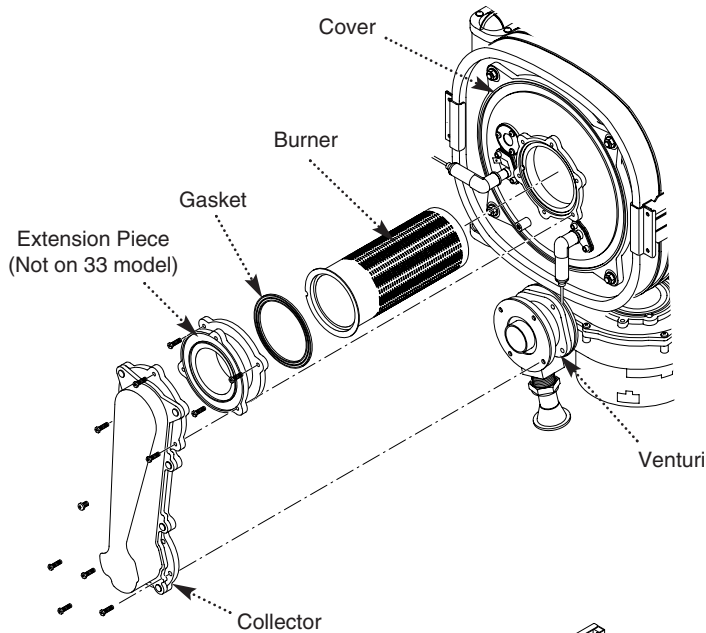

Fig. 51

### 12.7 Insulation (Fig. 52)

1. Remove the electrode leads, noting their positions. Also remove the electrodes as described in section 12.2.
2. Undo the screws securing the collector to the venturi and the nuts holding the cover to the heat exchanger. Draw the collector and cover assembly away.
3. Remove the cover insulation piece.
4. Fit the new insulation carefully over the burner and align it with the slots for the electrodes.
5. The rear insulation is retained by a screw and large washer, remove these and draw the insulation out of the heat exchanger.
6. Examine the cover seal and replace if necessary.

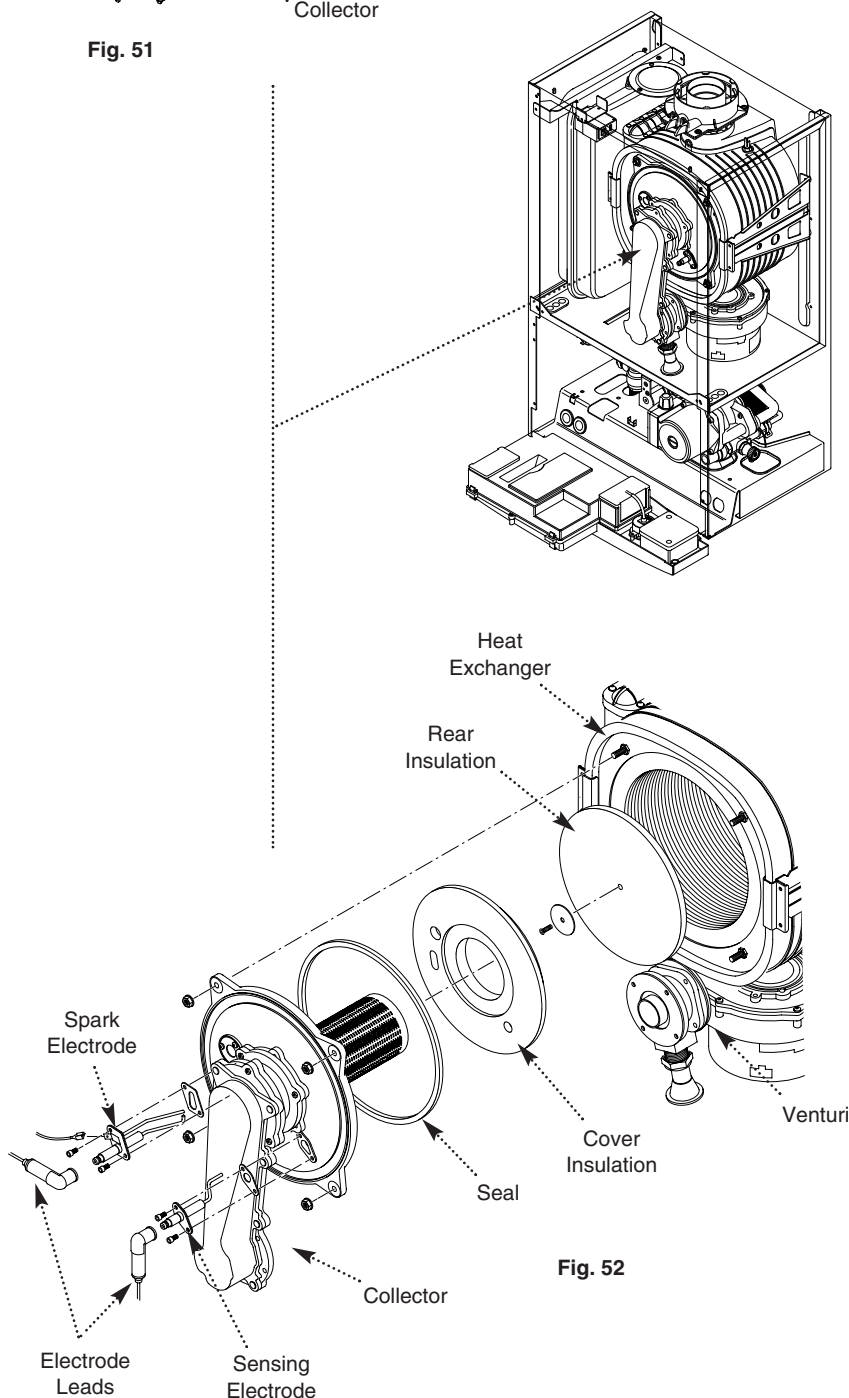

Fig. 52

## 12.0 CHANGING COMPONENTS

### 12.8 Flue/Heat Exchanger Thermostat Sensor (Fig. 53)

1. Ease the retaining tab on the sensor away and disconnect the electrical plug.
2. Turn the sensor 90° anticlockwise to remove - it is a bayonet connection.
3. Reassemble in reverse order.

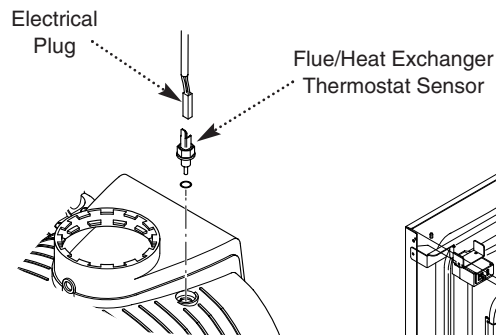
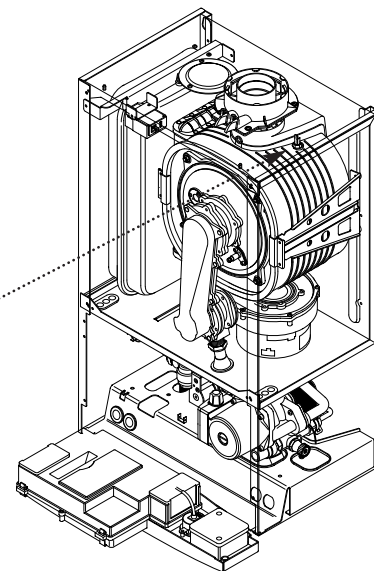

Fig. 53

### 12.9 Water Pressure Sensor (Fig. 54)

1. Drain the primary circuit.
2. Disconnect the two wires from the sensor.
3. Undo the nut on the flow pipe securing and sealing the sensor.
4. Remove the sensor, examine the sealing washer, replacing if necessary.
5. Reassemble in reverse order. The component is not polarised - either wire will fit each terminal.



### 12.10 Central Heating Temperature Sensor (NTC) (Fig. 54)

1. Ease the retaining tab on the sensor away and disconnect the electrical plug.
2. Unscrew the sensor from its pocket and reassemble in reverse order. The plug will only fit one way.

### 12.11 Safety Thermostat (Fig. 54)

1. Pull the plug off the thermostat.
2. Remove the screws securing the thermostat to the mounting plate on the flow pipe.
3. Reassemble in reverse order, ensuring that the plug is pushed fully on.

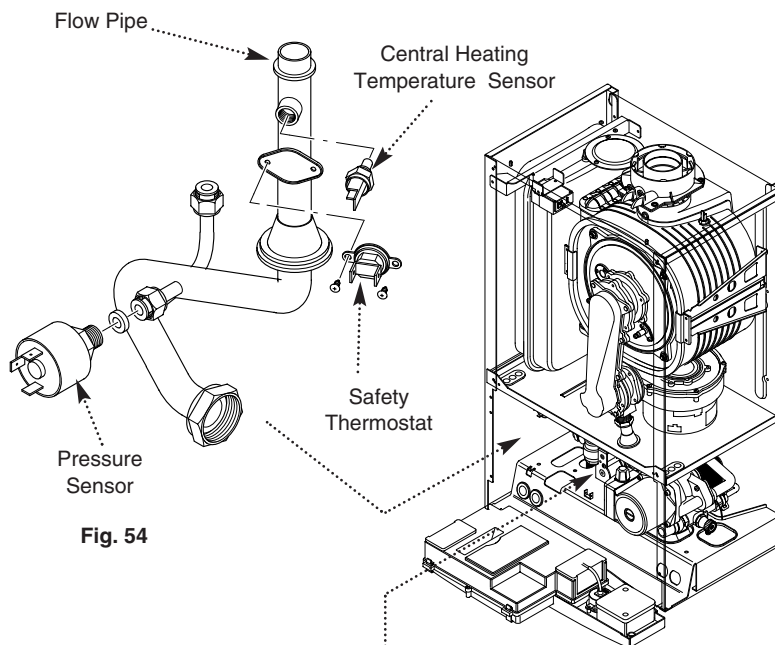

Fig. 54

### 12.12 DHW Temperature Sensor (NTC) (Fig. 55)

1. Turn off the mains cold water supply tap and draw off the residual domestic hot water.
2. Ease the retaining tab on the sensor away and disconnect the electrical plug.
3. Unscrew the sensor from the plate heat exchanger manifold. Examine the sealing washer, replacing if necessary.
4. Reassemble in reverse order. The plug will only fit one way.

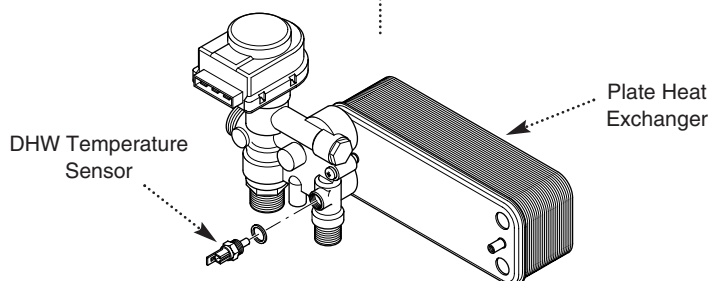

Fig. 55

## 12.0 CHANGING COMPONENTS

### 12.13 Pump - Head Only (Fig. 56)

1. Drain the primary circuit and remove the socket head screws securing the pump head to the body and draw the head away.
2. Undo the screw on the pump wiring cover and remove the cover. Using a suitable flat bladed screw driver press the cable securing levers downwards to release each wire after noting their position.
3. A standard replacement Grundfos 15-60 head can now be fitted. Connect the pump wiring to the new head. **The pump speed must be set to 3 (Fig. 57).**
4. Reassemble in reverse order.

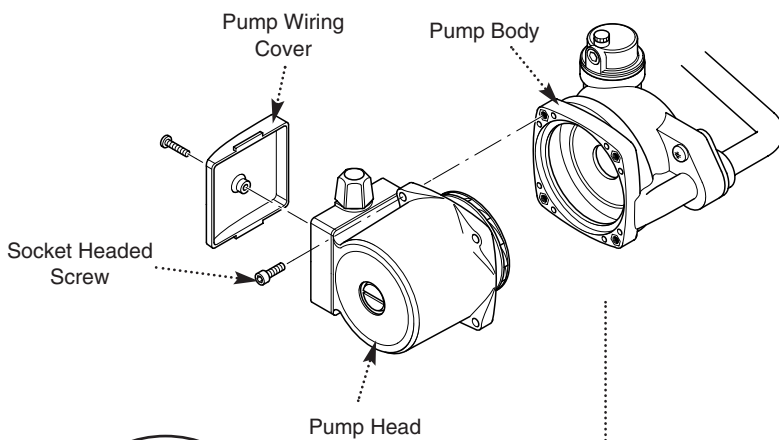
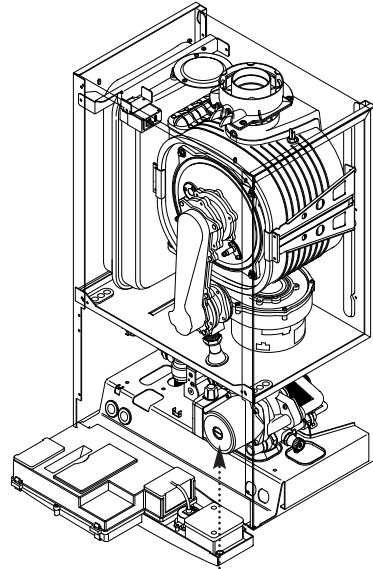
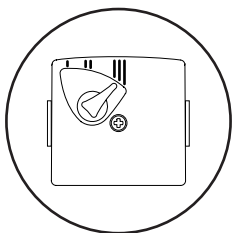

Fig. 56



Pump Setting

Fig. 57

### 12.14 Pump - Complete (Fig. 58)

1. Drain the primary circuit.
2. Undo the two screws securing the body to the pipe and manifold and draw the pump forwards.
3. Undo the screw on the pump wiring cover and remove the cover. Using a suitable flat bladed screw driver press the cable securing levers downwards to release each wire after noting their position.
4. Unscrew the automatic air vent from the pump body.
5. Connect the wiring to the new pump. Examine the 'O' ring seals on the return pipe and manifold, replacing if necessary.
6. Fit the air vent to the pump body and reassemble in reverse order.

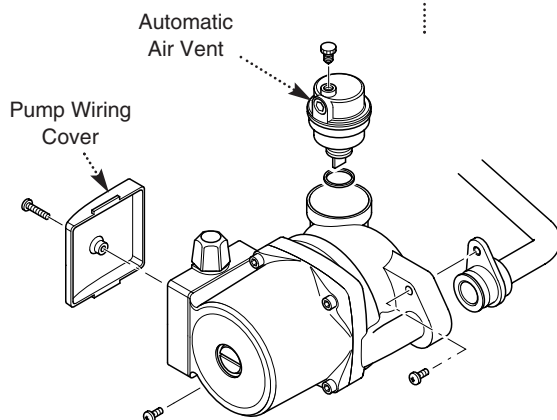

Fig. 58

### 12.15 Automatic Air Vent (Fig. 58)

1. Drain the primary circuit and unscrew the automatic air vent from the pump body.
2. Examine the 'O' ring seal, replacing if necessary, and fit it to the new automatic air vent.
3. Reassemble in reverse order.

## 12.0 CHANGING COMPONENTS

### 12.16 Pressure Gauge (Figs. 59 & 60)

1. Drain the primary circuit and undo the nut on the pressure gauge capillary.
2. Undo the screws securing the gauge retaining bracket.
3. Remove the bracket and gauge assembly. Depress the barbs on the side of the gauge and remove the retaining bracket.
4. Examine the sealing washer, replace if necessary.
5. Reassemble in reverse order.

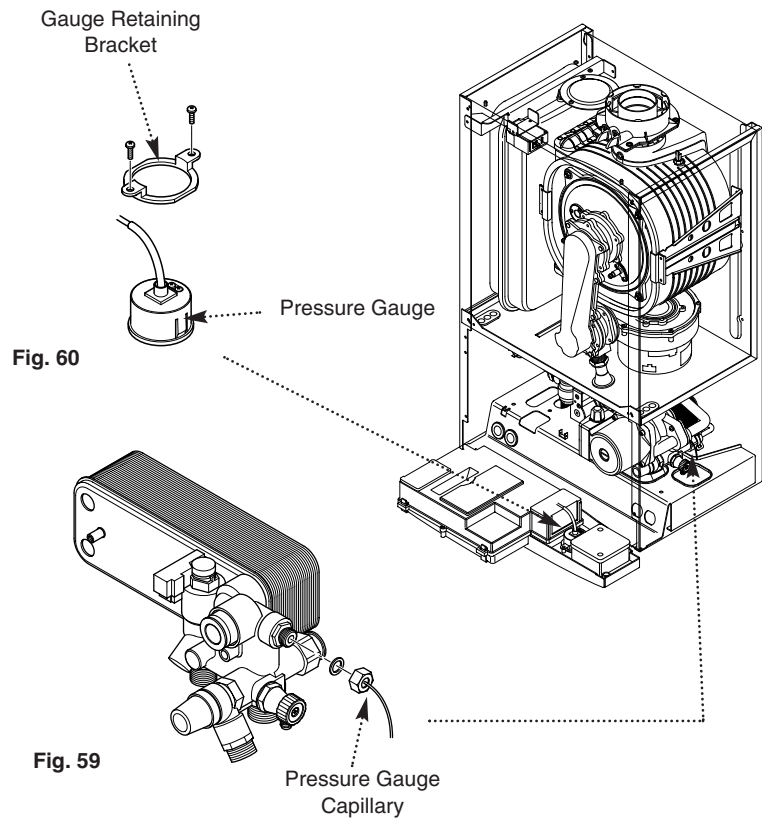

### 12.17 Hall Effect Sensor (Fig. 61)

1. Ease the sensor upwards off the hydraulic inlet manifold assembly.
2. Disconnect the electrical plug from the sensor.
3. Connect the plug to the new sensor. Carefully fit the new sensor to the hydraulic assembly, ensuring it is fully down.

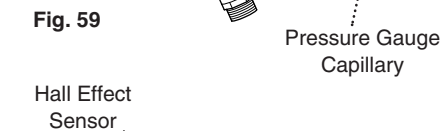

### 12.18 Pressure Relief Valve (Fig. 62)

1. Drain the primary circuit.
2. Disconnect the discharge pipe from the valve. Using a suitable hexagon key undo the grub screw sufficiently to release the valve.
3. Note the orientation of the valve, rotate it and withdraw it from the manifold.
4. Fit the new valve and 'O' ring seal and set to the previously noted orientation. Reassemble in reverse order.

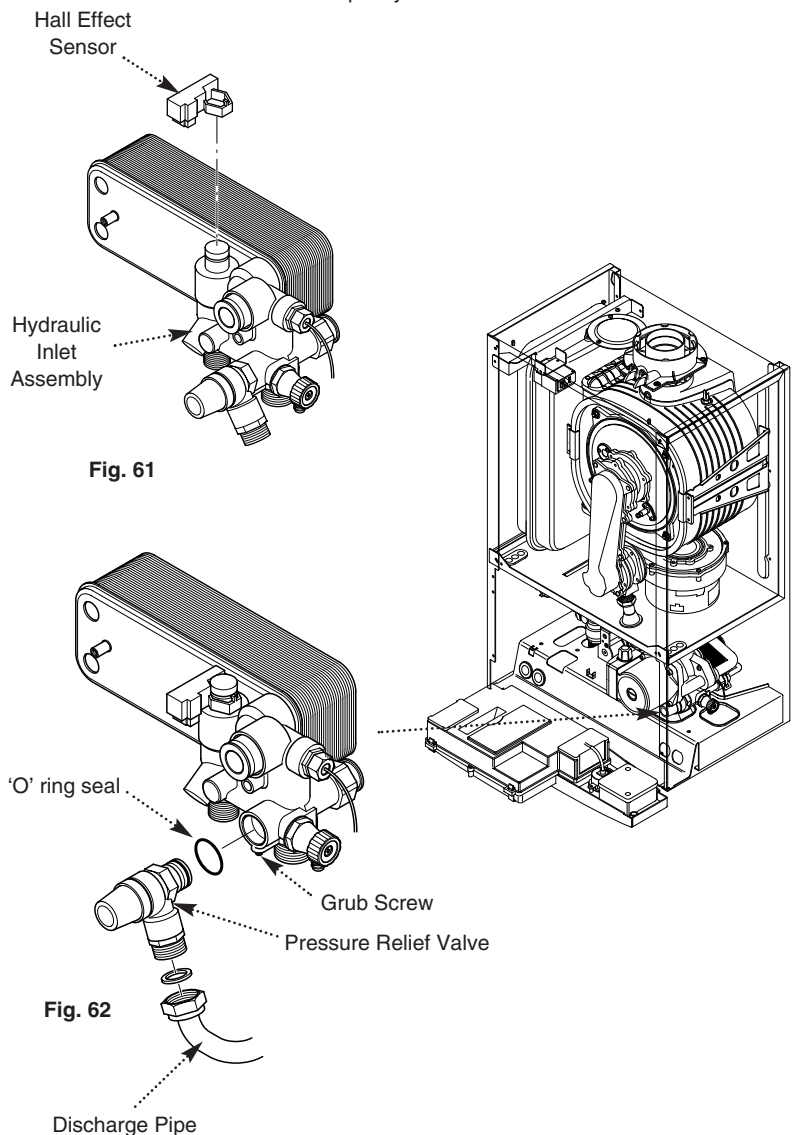

## 12.0 CHANGING COMPONENTS

### 12.19 Plate Heat Exchanger (Fig. 63)

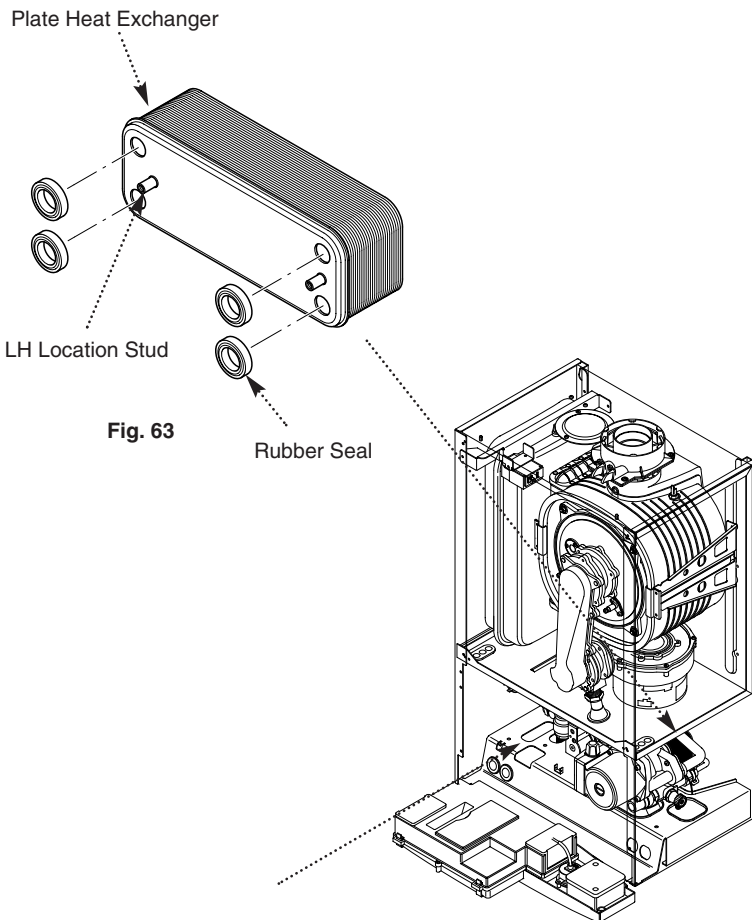

1. Drain the primary circuit and remove the gas valve as described in section 12.23.

2. While supporting the heat exchanger undo the screws securing it to the brass manifolds.

3. Withdraw the heat exchanger upwards, taking care not to damage any wires or controls.

#### Seals

4. There are four rubber seals between the manifolds and heat exchanger which may need replacement.

5. Ease the seals out of the manifold. Replace carefully, ensuring that when the seal is inserted into the manifold it is parallel and pushed fully in.

6. When fitting the new heat exchanger note that the left hand location stud is offset towards the centre more than the right hand one.

7. Reassemble in reverse order.

### 12.20 Diverter Valve - Motor Unit & Assembly (Figs. 64 & 65)

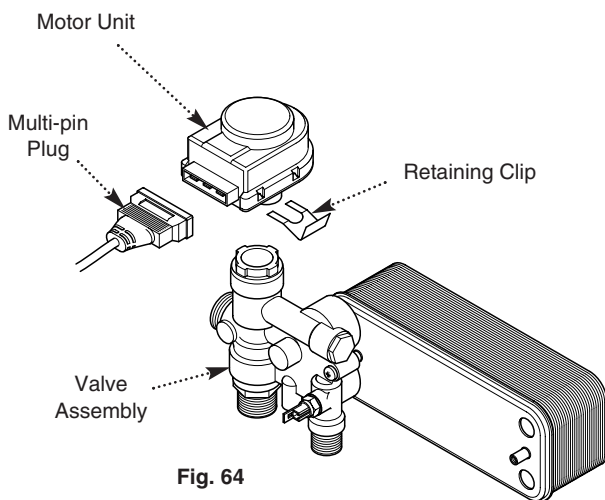

1. To replace the motor unit, disconnect the multi-pin plug.

2. Pull off the retaining clip and remove the motor unit.

3. The motor unit can now be replaced, or the valve assembly removed.

4. Drain the primary circuit and draw off any hot water once the isolating taps are closed.

5. Remove the spring clip retaining the bypass pipe to the rear of the assembly and under the flow pipe nut at the left hand side.

6. Undo the nuts on the tap rail under the boiler. Remove the screws securing the valve assembly to the boiler bottom panel and plate heat exchanger.

7. Remove the valve assembly. Examine any seals or washers, replacing if necessary. Transfer the DHW NTC to the new valve and reassemble in reverse order.

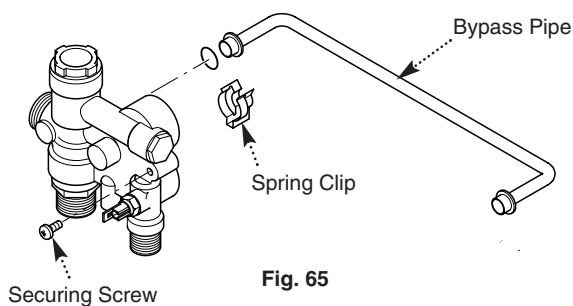



## 12.0 CHANGING COMPONENTS

### 12.21 P.C.B. (Fig. 67)

1. Note the settings of the temperature control knobs, rotate them fully anticlockwise and carefully pull them off the drive pins.

2. Completely undo the screws securing the control box cover and release the cover retaining barbs from their slots. Disengage the rear of the cover from the control box hinge pin (Fig. 65).

3. Note the position of all plugs and wires on the P.C.B. and disconnect them.

4. Undo the securing screws and remove the P.C.B. Transfer the control knob drive pins to the new P.C.B. and turn them fully anticlockwise.

5. Reassemble in reverse order, ensuring that the temperature controllers are reset to their previous positions.

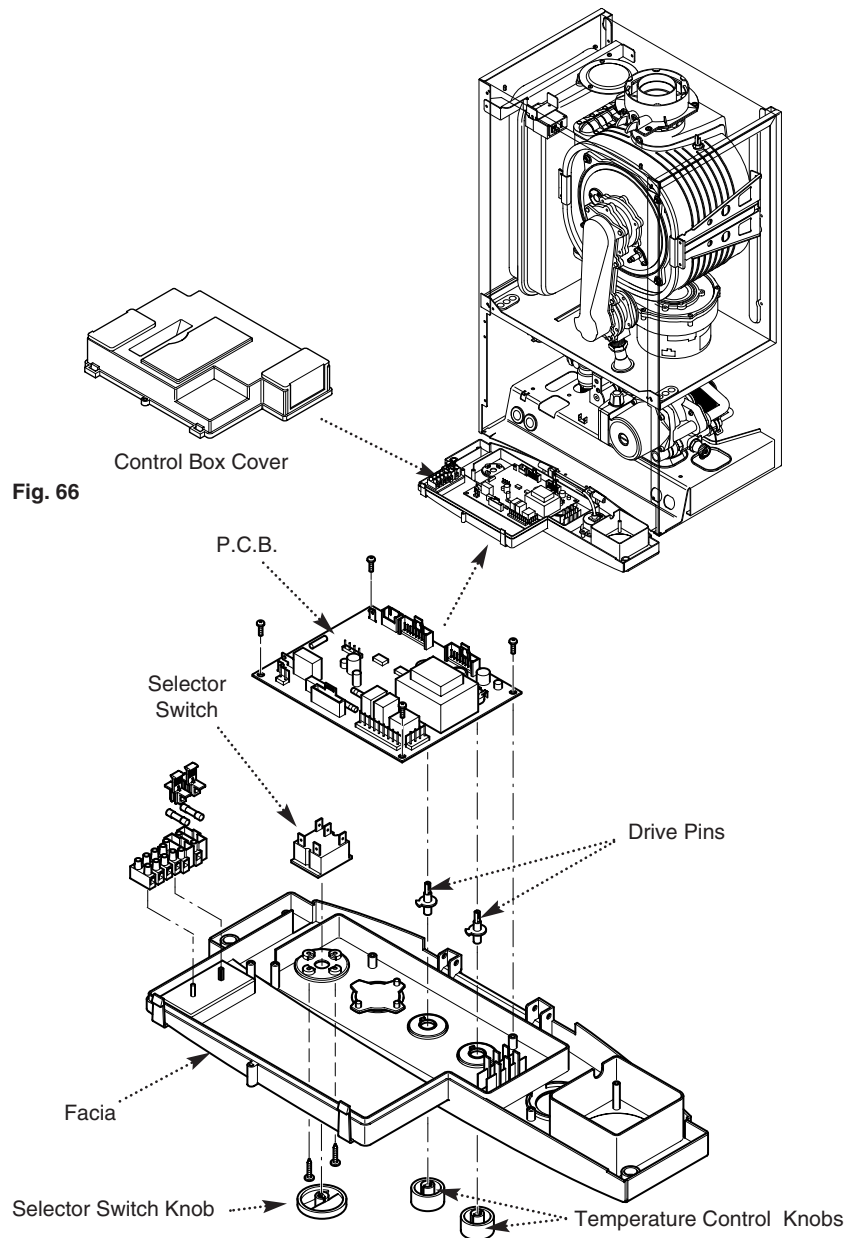

Fig. 66

Fig. 67

### 12.22 Selector Switch (Fig. 67)

1. Note the setting of the selector switch knob and carefully pull it off the facia.

2. Completely undo the screws securing the control box cover and release the cover retaining barbs from their slots. Disengage the rear of the cover from the control box hinge pin (Fig. 66).

3. Note the position of the electrical connections and the orientation of the switch. Remove the electrical connections.

4. Remove the screws securing the switch to the facia panel.

5. Fit the new switch, ensuring that it is correctly positioned and reassemble in reverse order.

## 12.0 CHANGING COMPONENTS

### 12.23 Gas Valve (Fig. 68)

1. Turn the gas cock off and undo the nut on the gas feed elbow under the boiler.
2. Remove the screws securing the inlet pipe flange to the boiler bottom panel.
3. Pull off the earth lead and sensing pipe.
4. Undo the nut on the venturi inlet pipe and slacken the nut on the venturi. Ease the pipe aside and remove the gas valve.
5. Remove the outlet adaptor and inlet pipe and transfer them to the new valve. Examine the 'O' ring seals, replace if necessary.
6. Reassemble in reverse order.

**IMPORTANT: The CO<sub>2</sub> must be checked and adjusted as detailed in Section 13.0 Combustion Check**

### 12.24 Expansion Vessel (Fig. 69)

1. Drain the primary circuit and undo the nut on the vessel connection pipe.
2. Undo and remove the locknut and spring washer securing the vessel spigot to the boiler air box.
3. Remove the bracket and vessel from the boiler.
4. Locate the retaining bracket on the upper flange of the vessel and fit to the boiler.
5. Reassemble in reverse order.

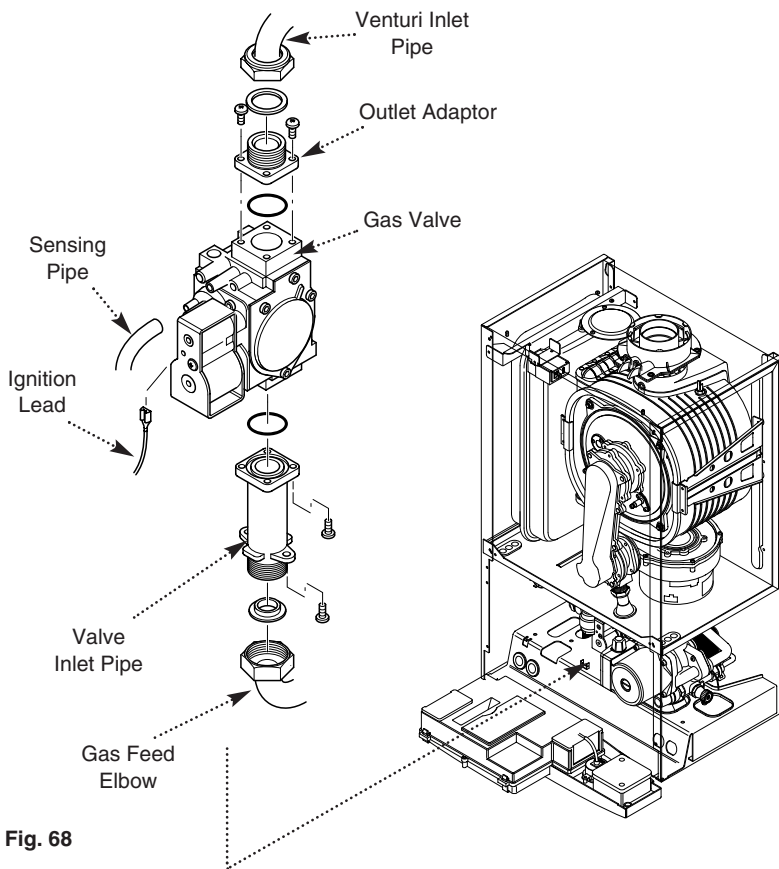

Fig. 68

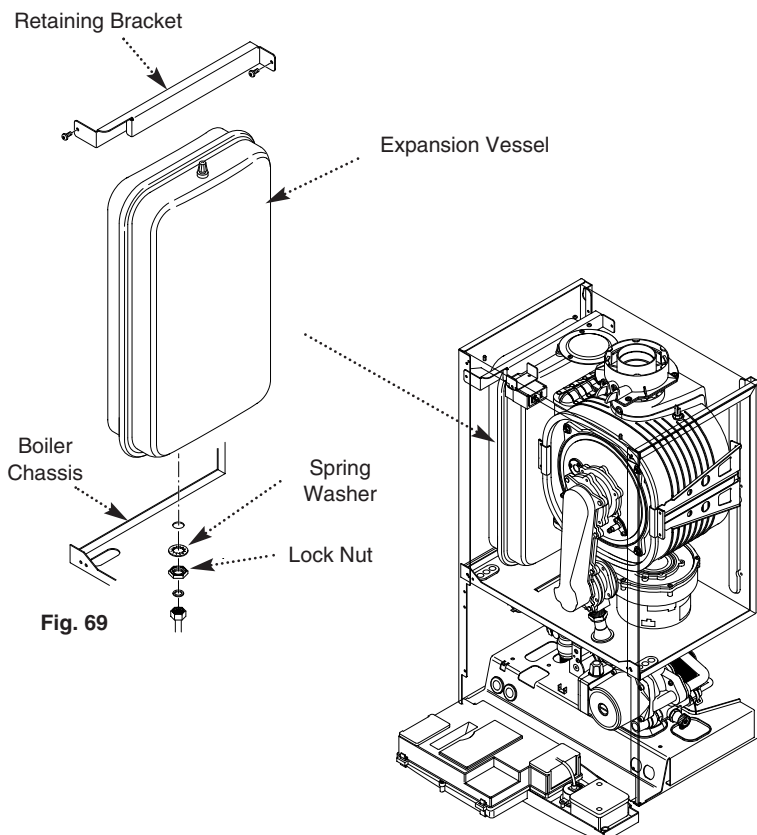

Fig. 69

## 13.0 COMBUSTION CHECK

**POTTERTON**

### 13.1 Checking the CO<sub>2</sub>

1. The combustion (CO<sub>2</sub>) may be checked using a suitably calibrated analyser after running the boiler for several minutes.
2. To do this it is necessary to set the boiler to 'Calibration Mode'.
3. Ensure that all external controls are calling for heat. The actual current boiler temperature is shown on the display.

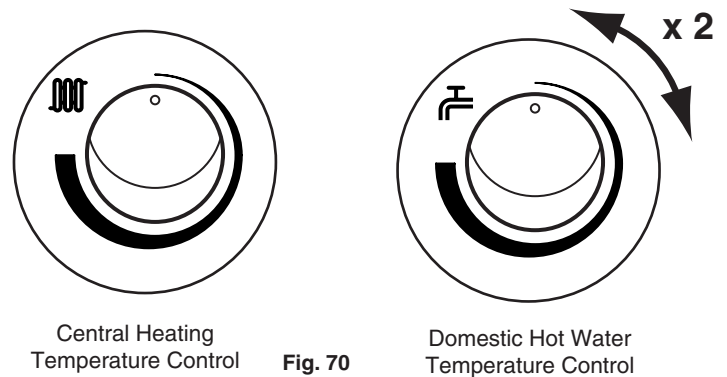

4. Turn both temperature control knobs fully anticlockwise, then quickly turn the DHW temperature knob 1/4 clockwise twice and back fully anticlockwise (Fig. 70).

5. The display will now alternate between 'SF' and the current boiler temperature and both green LEDs will flash (Figs. 71 & 72).

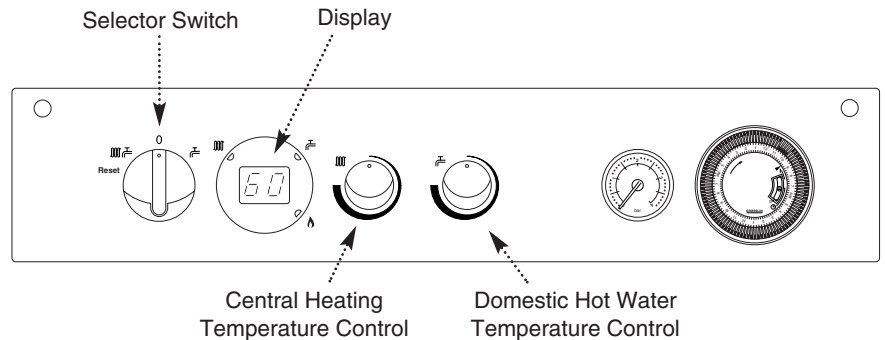

6. Turn the CH temperature knob fully clockwise. As the knob is turned the display will change, indicating the fan speed.

7. The display will show '00', indicating maximum rate, then revert to 'P' alternating with the current boiler temperature (Figs 73,74 & 75).

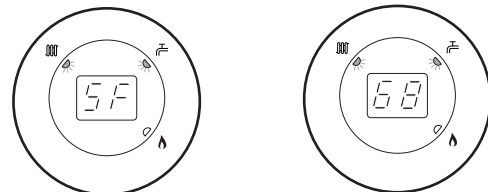

Fig. 71

Fig. 72

8. Remove the plug from the flue adaptor test point. Insert the analyser probe and allow time for the reading to settle (Fig. 76).

The CO<sub>2</sub> should be 8.7% ± 0.2

9. It is possible to alter the CO<sub>2</sub> by adjustment of the gas valve. Remove the cover from the 'Max. Rate' adjustment screw. At maximum rate the 'Max. Rate' adjustment screw should be turned, using a suitable hexagon key, until the correct reading is obtained (Fig. 77).

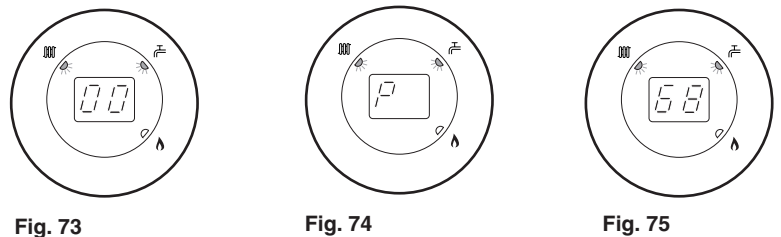

Fig. 73

Fig. 74

Fig. 75

10. The CO<sub>2</sub> must then be checked at minimum rate. Turn the CH temperature knob fully anticlockwise. As the knob is turned the display will change, indicating the fan speed. When the display reads '0' the boiler runs at minimum rate.

The CO<sub>2</sub> should be 8.4% ± 0.2.

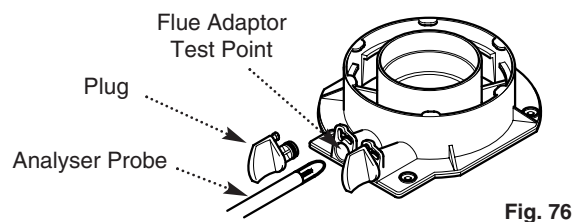

Fig. 76

11. With the boiler on minimum, the 'Min. Rate' adjustment screw must be altered, using a suitable hexagon key, after removing the cap (Fig. 77). If the CO<sub>2</sub> is reset at either boiler rate it must be rechecked at the other rate and also adjusted if required.

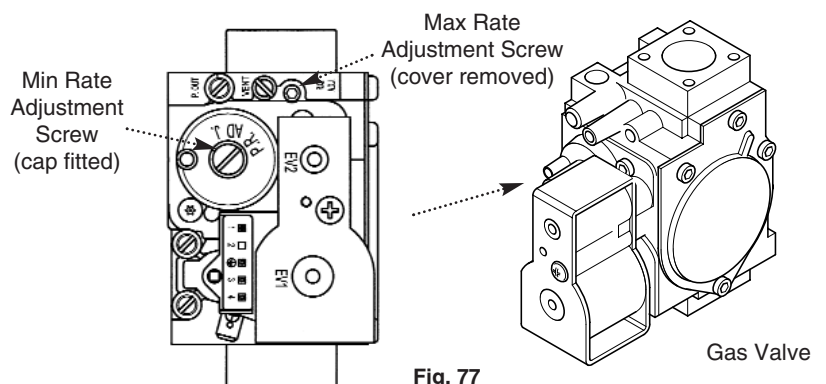
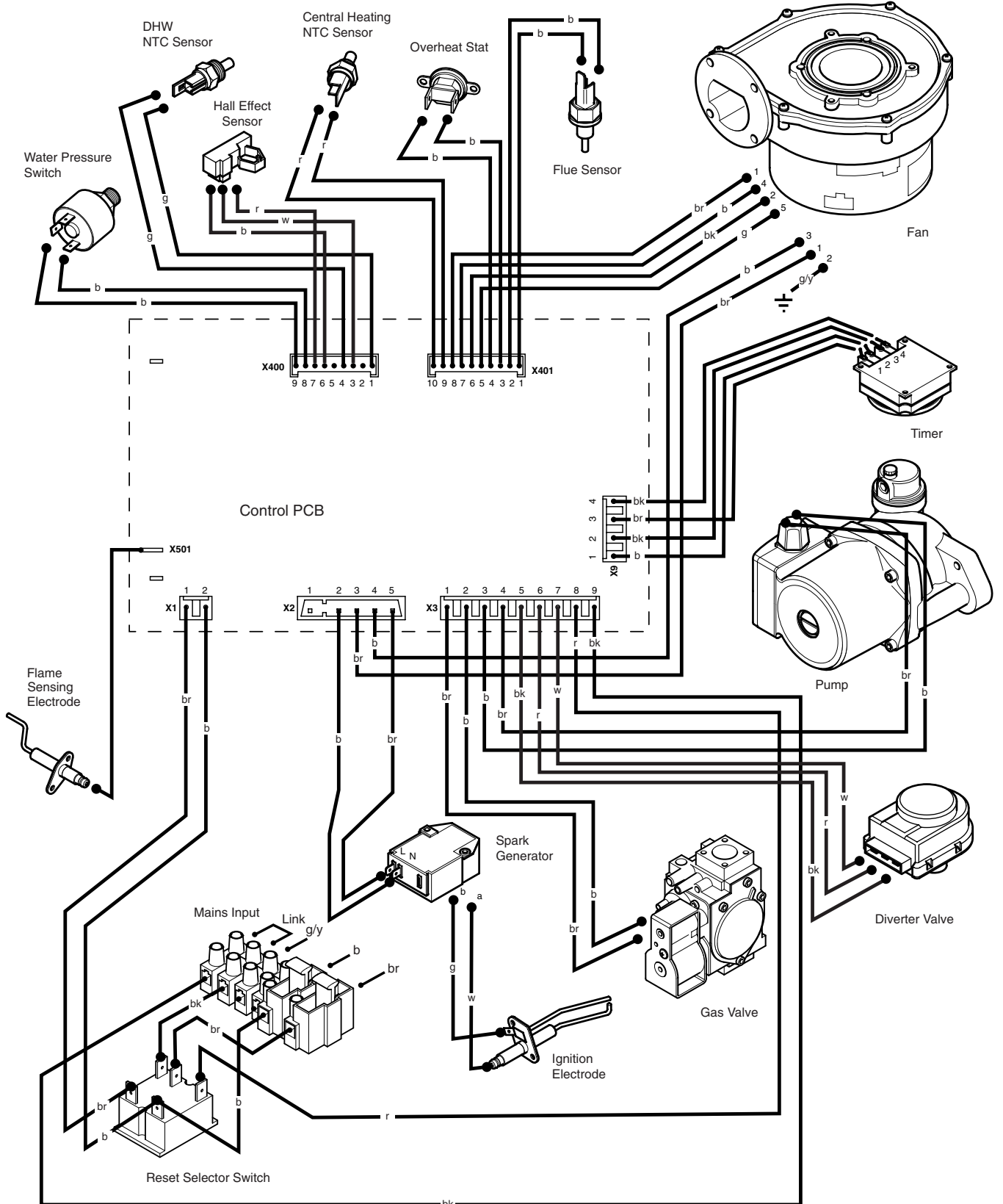

Fig. 77

12. The 'Calibration Function' is maintained for 20 minutes unless the maximum CH temperature is exceeded. The function can be disabled at any time by turning the DHW knob.

# 14.0 ELECTRICAL

## 14.1 Illustrated Wiring Diagram



br - brown    g - green  
 bk - black    g/y - green / yellow  
 b - blue      r - red  
 w - white

# 15.0 SHORT PARTS LIST



## Short Parts List

Key No.	Description	Manufacturers Part No.
311	Fan	5114684
426	Motor 3way Valve	248733
315	Igniter Electrode	5114702
316	Sensing Electrode	5114703
422	Gas Valve	5114734
624	Hall Effect Sensor	5114767
306	Burner 24 & 28 Burner 33	5114697 5114698
419	Water Pressure Switch	5114748
400	Plate Heat Exchanger	5114708
415	Pump	248042
302	Flue Thermostat	5114747
421	NTC Sensor	5114725
420	Overheat Thermostat	5114729
504	Pressure Gauge	248090
503	PCB 24 PCB 28 PCB 33	5116024 5115062 5114745

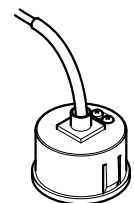
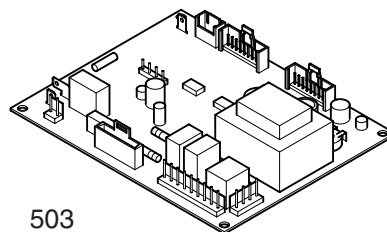
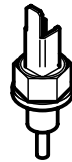
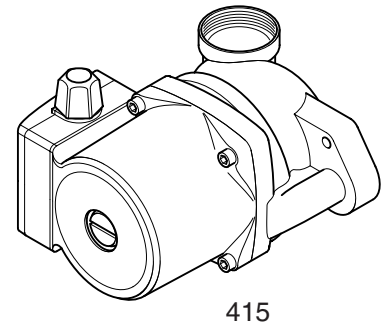
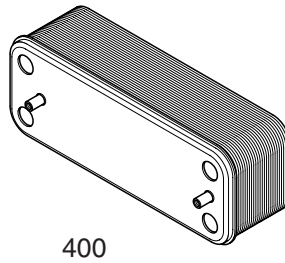
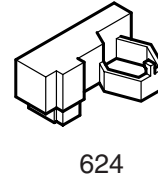
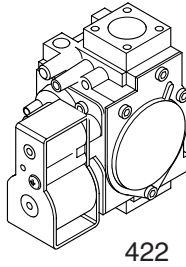
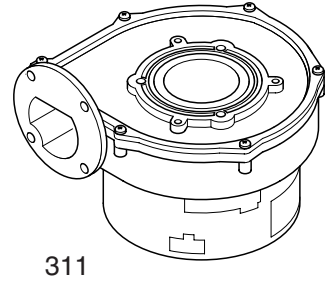
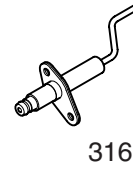
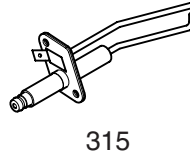
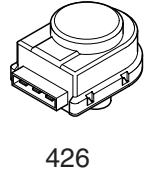
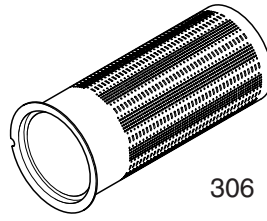

## 16.0 FAULT FINDING

**NOTE:** When instructed to turn the selector to the reset position turn the selector switch fully anticlockwise against the spring pressure to the reset position and hold for 5 seconds to reset the boiler.

### Carry out initial fault finding checks

1. Check that gas, water and electrical supplies are available at the boiler.
2. Electrical supply = 230V ~ 50 Hz.
3. CH water system pressurised to 0.5 bar minimum when the boiler is cold.
4. The preferred minimum gas pressure is 20 mbar.
5. Carry out electrical system checks, i.e. Earth Continuity, Resistance to Earth, Short Circuit and Polarity with a suitable meter.

**NOTE:** These checks must be repeated after any servicing or fault finding.

6. Ensure all external controls are calling for heat and check all external and internal fuses. Before any servicing or replacement of parts, ensure the gas and electrical supplies are isolated.

### Error Codes

1. If a fault occurs on the boiler an error code may be shown by the facia display.
2. The codes are either two or three digit, preceded by the letter 'E'. For example, code E133 will be displayed by 'E1' alternating with '33'. E50 is shown as 'E' then '50'

E20, E28 & E50 indicate faulty components.

E110 shows overheat of the primary water and E130 overheat of the flue system.

E119 is displayed when the primary water pressure is less than 0.5 bar.

E133 indicates that the gas supply has been interrupted, ignition has failed or the flame has not been detected.

E125 is displayed in either of two situations:-

i) If within 15 seconds of the burner lighting the boiler temperature has not changed by 1°.

ii) If within 10 minutes of the burner lighting the boiler temperature twice exceeds the selected temperature by 30°.

In these instances the pump is probably inoperative.

3. By turning the selector switch to the 'Reset' position for a minimum of 5 seconds when E110, E130 & E133 are displayed it is possible to relight the boiler.

4. If this does not have any effect, or the codes are displayed regularly further investigation is required.

**Table Of Error Codes**

E20	Central Heating NTC Fault
E50	Flue NTC Fault
E28	Hot Water NTC Fault
E110	Safety Thermostat Operated
E119	Water Pressure Switch Not Operated
E125	Pump Fault
E130	Flue NTC Operated
E133	Interruption Of Gas Supply or Flame Failure
E160	Fan or Fan Wiring Fault

# 16.0 FAULT FINDING



Refer to Section 14.0 "Illustrated Wiring Diagram" for position of terminals and components  
**Central Heating** - Follow operational sequence

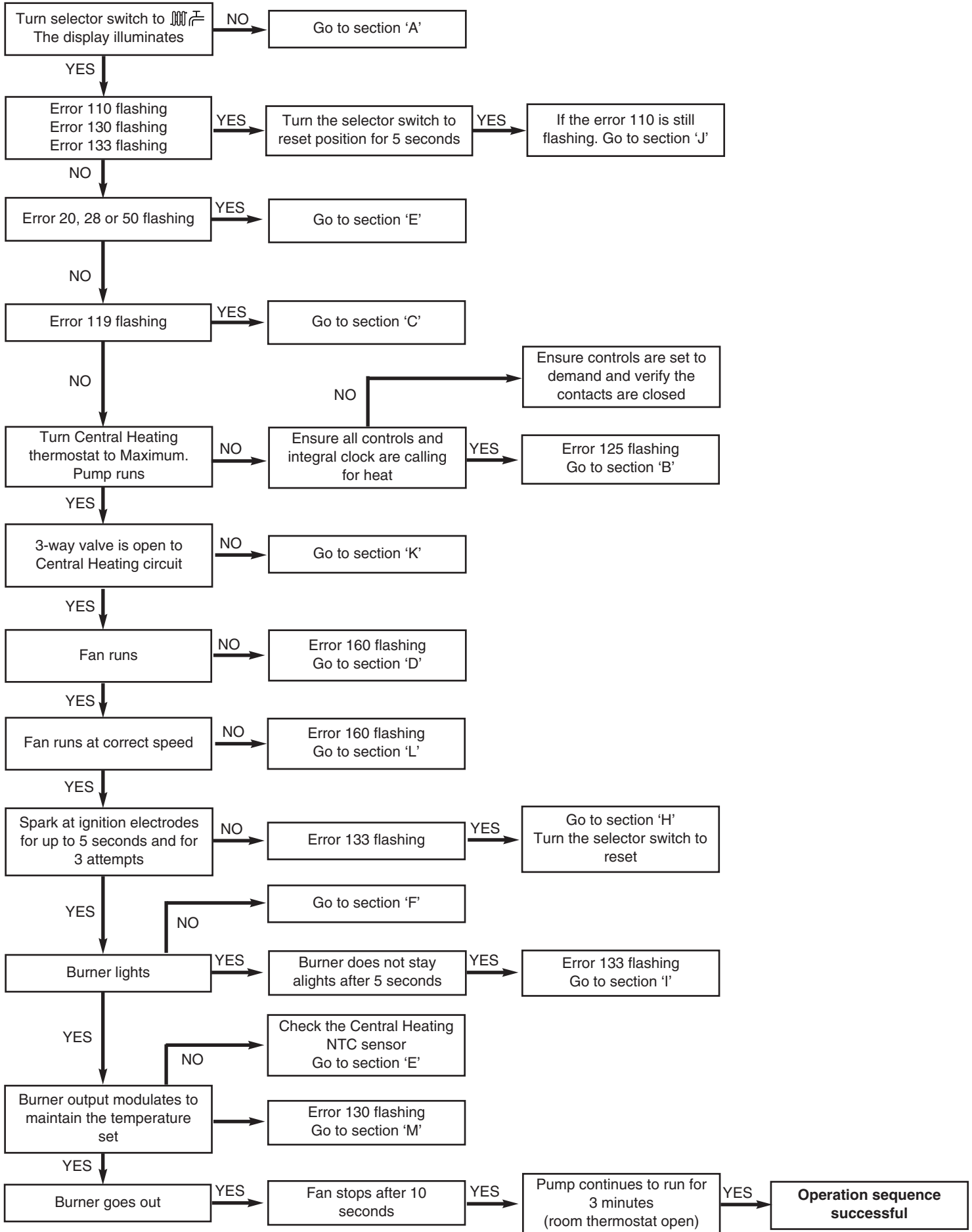

## 16.0 FAULT FINDING

Domestic Hot Water - Follow operational sequence

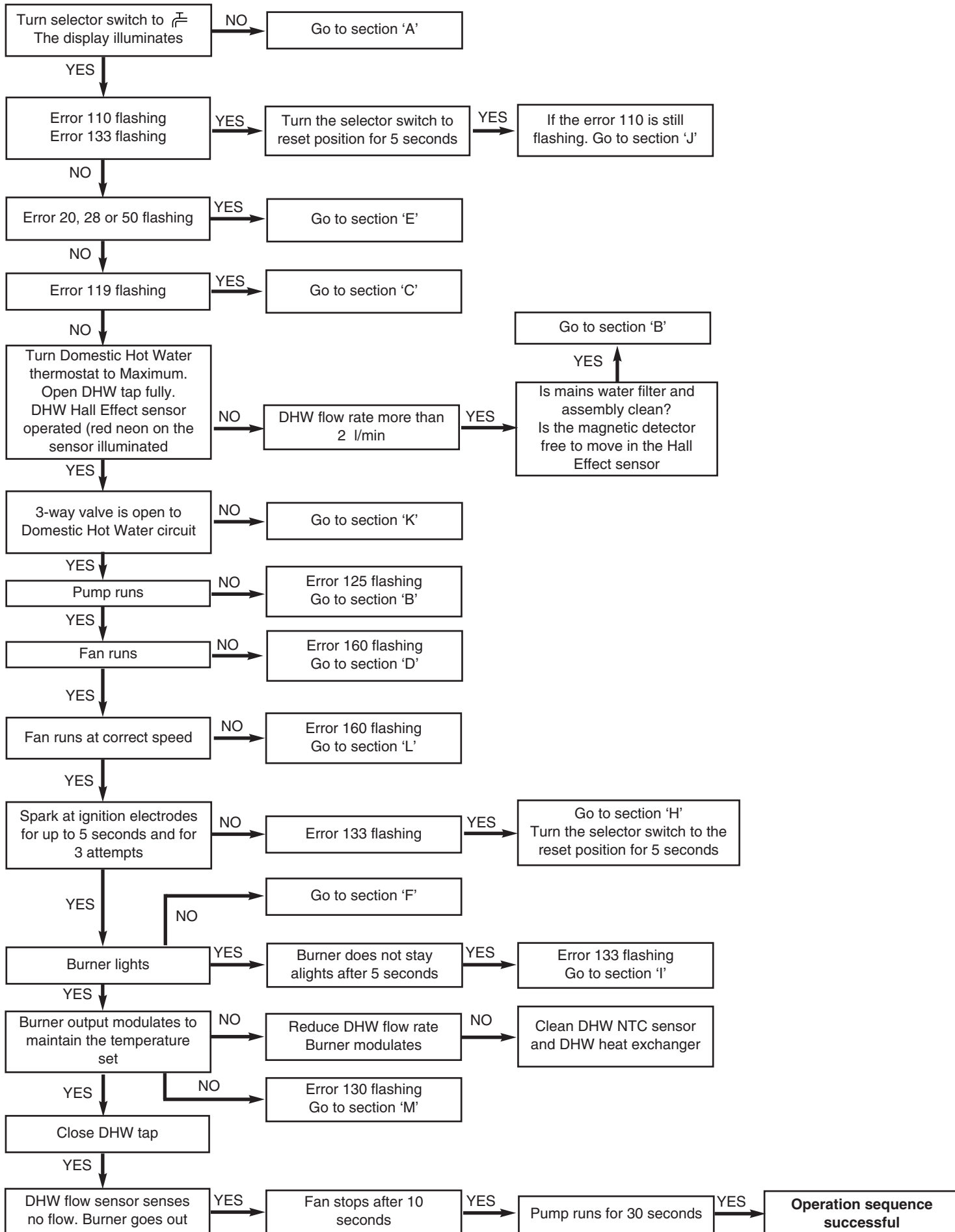



**Fault Finding Solutions Sections**

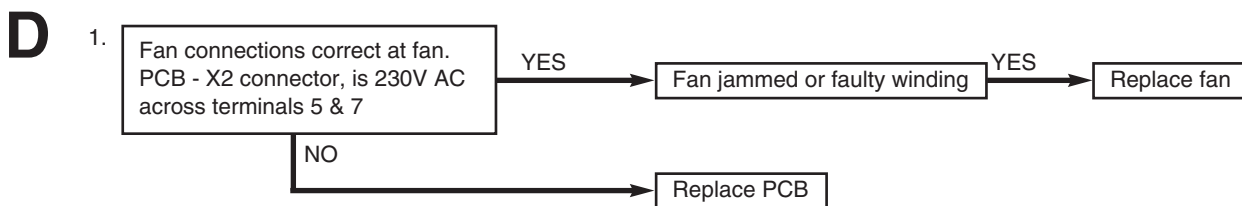
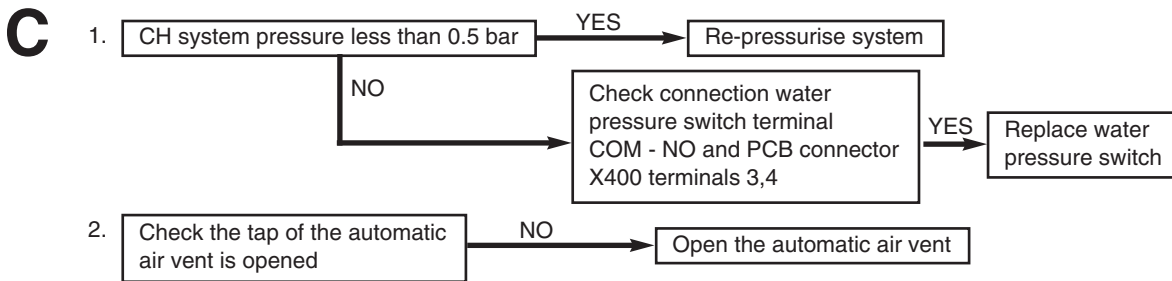
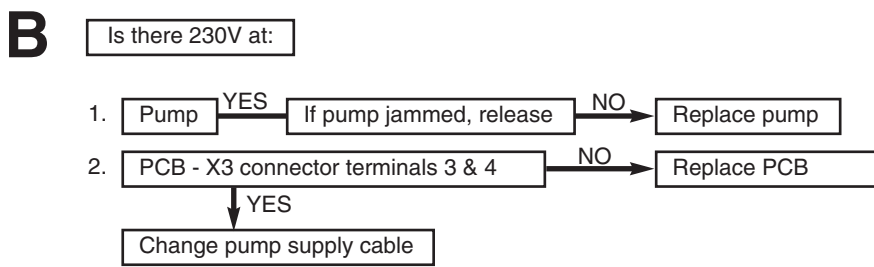
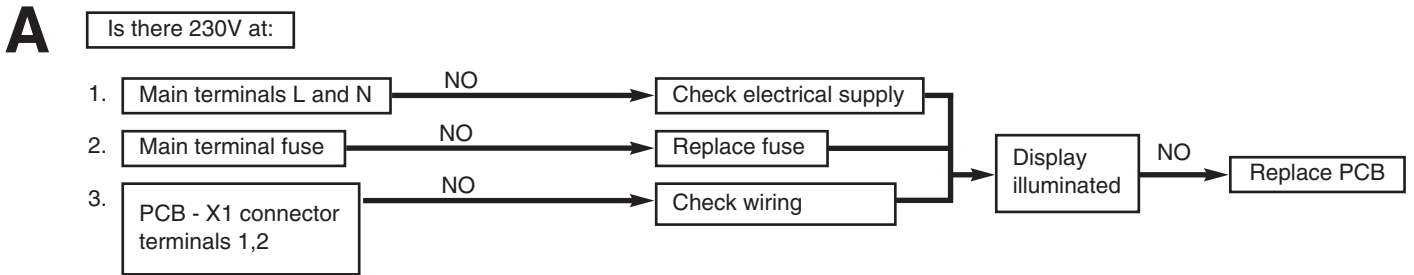

**E**

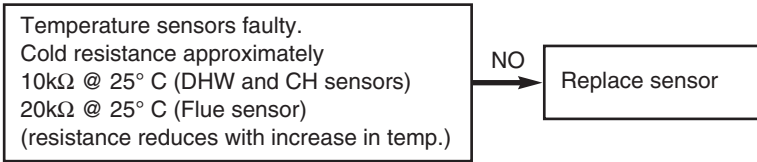

**F**

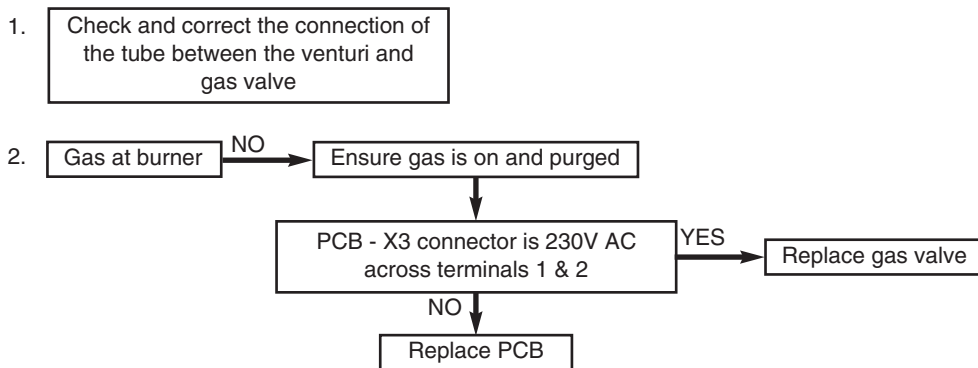

**G**

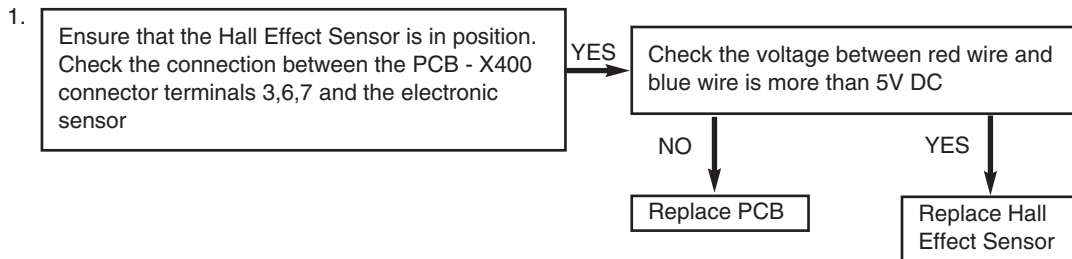

**H**

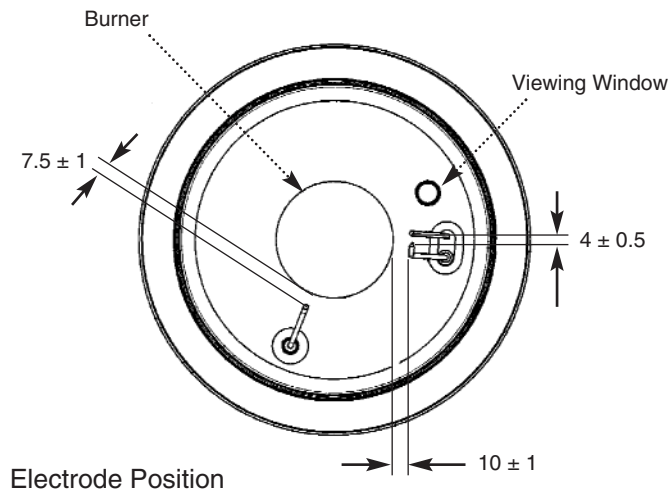
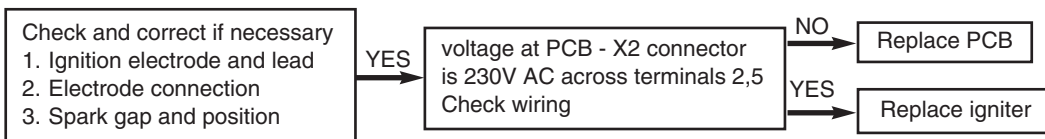

## 16.0 FAULT FINDING

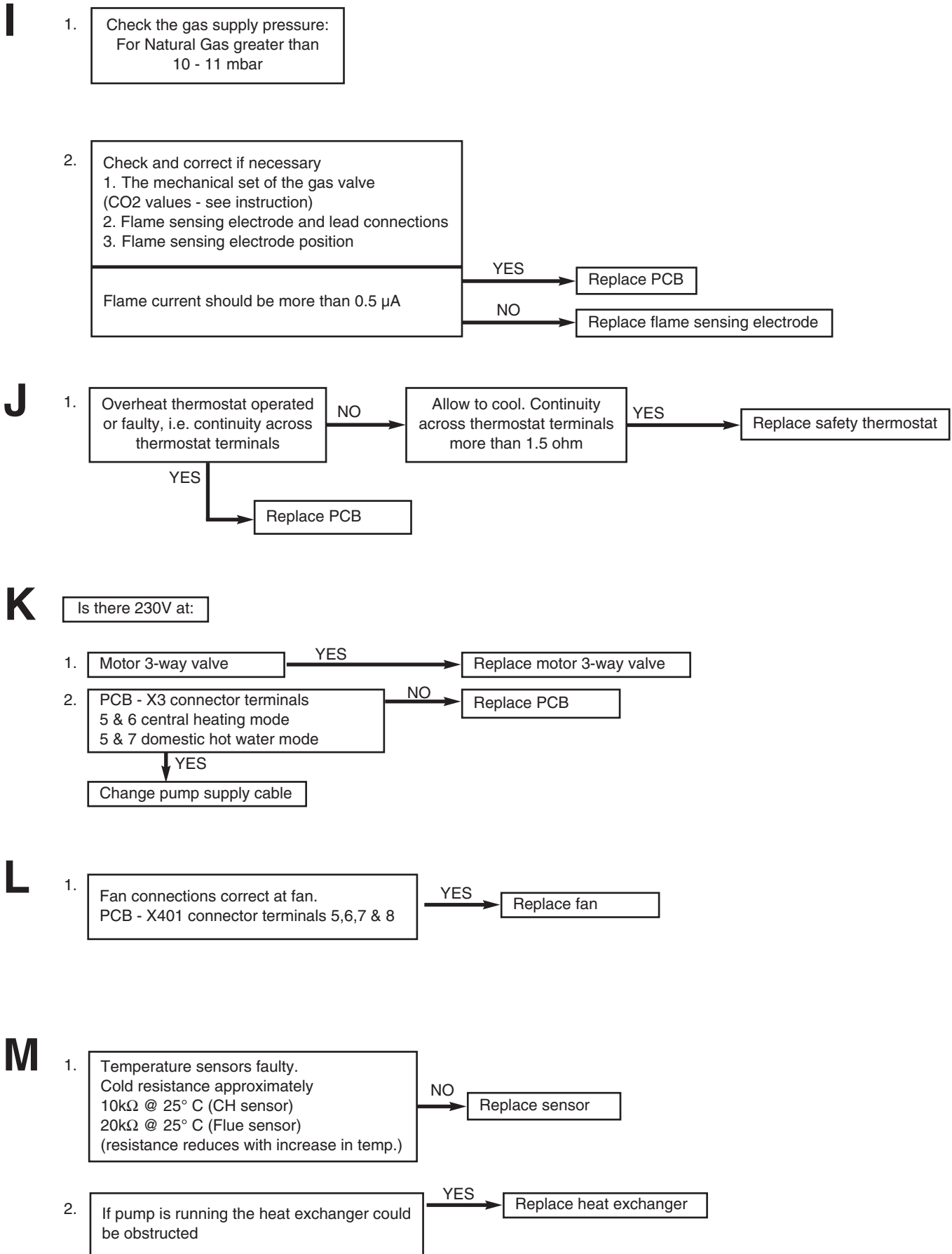







# GAS BOILER COMMISSIONING CHECKLIST

BOILER SERIAL No. \_\_\_\_\_ NOTIFICATION No. \_\_\_\_\_

**CONTROLS** To comply with the Building Regulations, each section must have a tick in one or other of the boxes

TIME & TEMPERATURE CONTROL TO HEATING	ROOM T/STAT & PROGRAMMER/TIMER <input type="checkbox"/>	PROGRAMMABLE ROOMSTAT <input type="checkbox"/>
TIME & TEMPERATURE CONTROL TO HOT WATER	CYLINDER T/STAT & PROGRAMMER/TIMER <input type="checkbox"/>	COMBI BOILER <input type="checkbox"/>
HEATING ZONE VALVES	FITTED <input type="checkbox"/>	NOT REQUIRED <input type="checkbox"/>
HOT WATER ZONE VALVES	FITTED <input type="checkbox"/>	NOT REQUIRED <input type="checkbox"/>
THERMOSTATIC RADIATOR VALVES	FITTED <input type="checkbox"/>	
AUTOMATIC BYPASS TO SYSTEM	FITTED <input type="checkbox"/>	NOT REQUIRED <input type="checkbox"/>

### FOR ALL BOILERS CONFIRM THE FOLLOWING

THE SYSTEM HAS BEEN FLUSHED IN ACCORDANCE WITH THE BOILER MANUFACTURER'S INSTRUCTIONS?

THE SYSTEM CLEANER USED \_\_\_\_\_

THE INHIBITOR USED \_\_\_\_\_

### FOR THE CENTRAL HEATING MODE, MEASURE & RECORD

GAS RATE \_\_\_\_\_ m<sup>3</sup>/hr \_\_\_\_\_ ft<sup>3</sup>/hr

BURNER OPERATING PRESSURE (IF APPLICABLE)  N/A \_\_\_\_\_ mbar

CENTRAL HEATING FLOW TEMPERATURE \_\_\_\_\_ °C

CENTRAL HEATING RETURN TEMPERATURE \_\_\_\_\_ °C

### FOR COMBINATION BOILERS ONLY

HAS A WATER SCALE REDUCER BEEN FITTED? YES  NO

WHAT TYPE OF SCALE REDUCER HAS BEEN FITTED? \_\_\_\_\_

### FOR THE DOMESTIC HOT WATER MODE, MEASURE & RECORD

GAS RATE \_\_\_\_\_ m<sup>3</sup>/hr \_\_\_\_\_ ft<sup>3</sup>/hr

MAXIMUM BURNER OPERATING PRESSURE (IF APPLICABLE)  N/A \_\_\_\_\_ mbar

COLD WATER INLET TEMPERATURE \_\_\_\_\_ °C

HOT WATER OUTLET TEMPERATURE \_\_\_\_\_ °C

WATER FLOW RATE \_\_\_\_\_ lts/min

### FOR CONDENSING BOILERS ONLY CONFIRM THE FOLLOWING

THE CONDENSATE DRAIN HAS BEEN INSTALLED IN ACCORDANCE WITH THE MANUFACTURER'S INSTRUCTIONS? YES

### FOR ALL INSTALLATIONS CONFIRM THE FOLLOWING

THE HEATING AND HOT WATER SYSTEM COMPLIES WITH CURRENT BUILDING REGULATIONS

THE APPLIANCE AND ASSOCIATED EQUIPMENT HAS BEEN INSTALLED AND COMMISSIONED IN ACCORDANCE WITH THE MANUFACTURER'S INSTRUCTIONS

IF REQUIRED BY THE MANUFACTURER, HAVE YOU RECORDED A CO/CO<sub>2</sub> RATIO READING? N/A  YES  CO/CO<sub>2</sub> RATIO \_\_\_\_\_

THE OPERATION OF THE APPLIANCE AND SYSTEM CONTROLS HAVE BEEN DEMONSTRATED TO THE CUSTOMER

THE MANUFACTURER'S LITERATURE HAS BEEN LEFT WITH THE CUSTOMER

COMMISSIONING ENG'S NAME PRINT \_\_\_\_\_ CORGI ID No. \_\_\_\_\_

SIGN \_\_\_\_\_ DATE \_\_\_\_\_

# SERVICE INTERVAL RECORD

It is recommended that your heating system is serviced regularly  
and that you complete the appropriate Service Interval Record Below.

**Service Provider.** Before completing the appropriate Service Interval Record below, please ensure you have carried out the service as described in the boiler manufacturer's instructions. Always use the manufacturer's specified spare part when replacing all controls

## SERVICE 1 DATE

ENGINEER NAME

COMPANY NAME

TEL No.

CORGI ID CARD SERIAL No.

COMMENTS

SIGNATURE

## SERVICE 2 DATE

ENGINEER NAME

COMPANY NAME

TEL No.

CORGI ID CARD SERIAL No.

COMMENTS

SIGNATURE

## SERVICE 3 DATE

ENGINEER NAME

COMPANY NAME

TEL No.

CORGI ID CARD SERIAL No.

COMMENTS

SIGNATURE

## SERVICE 4 DATE

ENGINEER NAME

COMPANY NAME

TEL No.

CORGI ID CARD SERIAL No.

COMMENTS

SIGNATURE

## SERVICE 5 DATE

ENGINEER NAME

COMPANY NAME

TEL No.

CORGI ID CARD SERIAL No.

COMMENTS

SIGNATURE

## SERVICE 6 DATE

ENGINEER NAME

COMPANY NAME

TEL No.

CORGI ID CARD SERIAL No.

COMMENTS

SIGNATURE

## SERVICE 7 DATE

ENGINEER NAME

COMPANY NAME

TEL No.

CORGI ID CARD SERIAL No.

COMMENTS

SIGNATURE

## SERVICE 8 DATE

ENGINEER NAME

COMPANY NAME

TEL No.

CORGI ID CARD SERIAL No.

COMMENTS

SIGNATURE

## SERVICE 9 DATE

ENGINEER NAME

COMPANY NAME

TEL No.

CORGI ID CARD SERIAL No.

COMMENTS

SIGNATURE

## SERVICE 10 DATE

ENGINEER NAME

COMPANY NAME

TEL No.

CORGI ID CARD SERIAL No.

COMMENTS

SIGNATURE

**General Enquiries (GB)**

Tel. **08706 060 780**

**Technical (GB)**

Tel. **08706 049 049**

**Service (GB)**

Tel. **08706 017 017**

Fax. **01926 410 006**

**Literature Request (GB)**

Tel. **08706 060 623**

**Technical (IE)**

Tel. **1850 560570**

All descriptions and illustrations provided in this leaflet have been carefully prepared but we reserve the right to make changes and improvements in our products which may affect the accuracy of the information contained in this leaflet. All goods are sold subject to our standard Conditions of Sale which are available on request.

**BAXI POTTERTON**

A Trading Division of Baxi Heating UK Ltd

Brownedge Road Bamber Bridge Preston Lancashire PR5 6UP

After Sales Service 08706 017 017 Technical Enquiries 08706 049 049

Website [www.potterton.co.uk](http://www.potterton.co.uk)