

POTTERTON

Performa 28

Gas Fired Wall Mounted Combination Boiler

Installation and Servicing Instructions

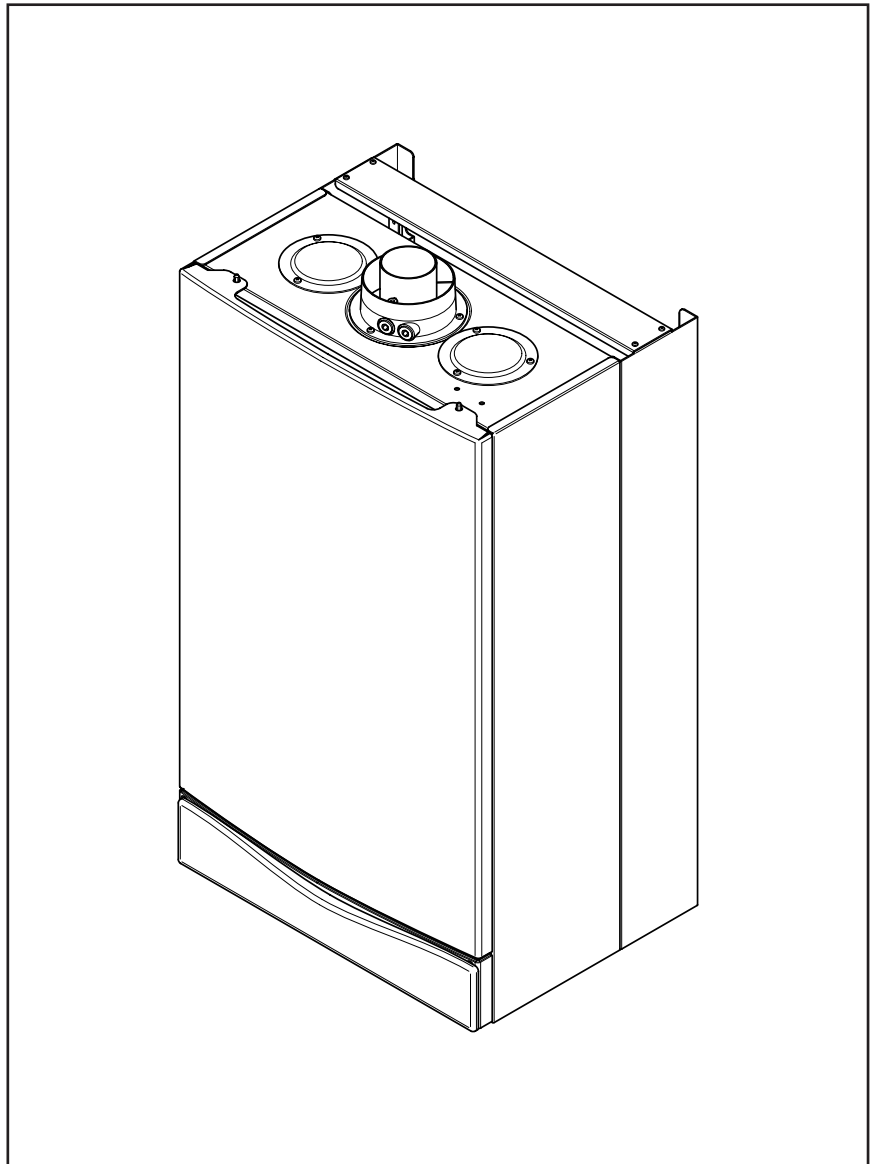

Please leave these instructions with the user

Natural Gas

Potterton Performa 28
G.C.N° 47 393 07



The boiler meets the requirements of Statutory Instrument “ The Boiler (Efficiency) Regulations 1993 N° 3083” and is deemed to meet the requirements of Directive 92/42/EEC on the energy efficiency requirements for new hot water boilers fired with liquid or gaseous fuels:-

Type test for purpose of Regulation 5 certified by:
Notified Body 0051.

Product/Production certified by:
Notified Body 0051.

For GB/IE only.

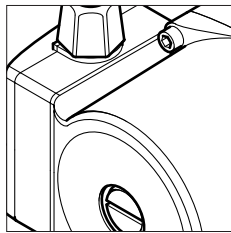
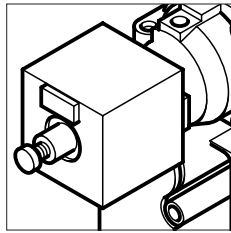
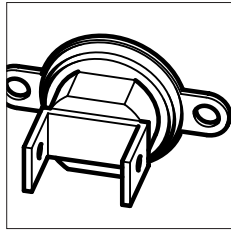

Contents

Section	Page
1.0 Introduction	4
2.0 General Layout	5
3.0 Appliance Operation	6
4.0 Technical Data	7
5.0 Dimensions and Fixings	8
6.0 System Details	9
7.0 Site Requirements	12
8.0 Installation	17
9.0 Commissioning the Boiler	22
10.0 Completion	24
11.0 Servicing the Boiler	25
12.0 Changing Components	27
13.0 Illustrated Wiring Diagram	36
14.0 Fault Finding	37
15.0 Short Parts List	42

1.0 Introduction

Potterton declare that no substances harmful to health are contained in the appliance or used during appliance manufacture.

1.1 Description

1. The Potterton Performa 28 is a fully automatic gas fired wall mounted combination boiler. It is room sealed and fan assisted, and will serve central heating and mains fed domestic hot water.
2. The boiler is set to give a maximum output of 29.4 kW.
3. It is designed for use on Natural Gas (G20) and can be converted to use Propane.
4. The boiler is suitable for use only on fully pumped sealed heating systems. Priority is given to domestic hot water.
5. The boiler data badge gives details of the model, serial number and Gas Council number and is situated on the control box. It is visible when the case front panel is removed (Fig. 1).
6. The boiler is intended to be installed in residential / commercial / light industrial E.M.C. environments on a governed meter supply only.
7. The boiler must be installed with one of the purpose designed flues such as the standard horizontal flue kit, part no. 247719.
8. **All systems must be thoroughly flushed and treated with inhibitor (see section 6.2).**

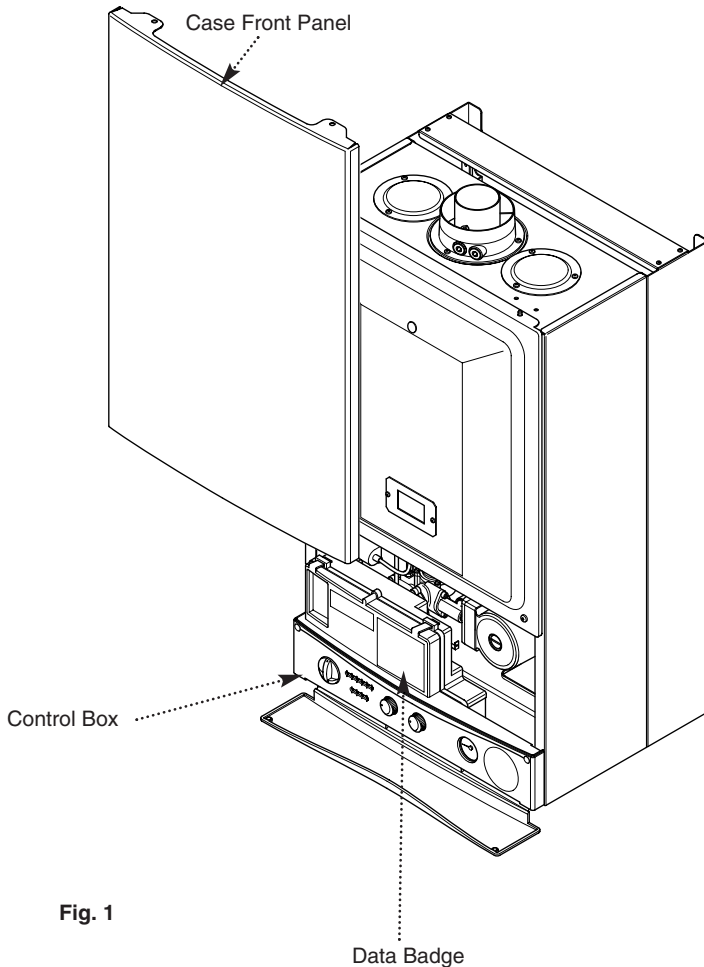

Fig. 1

NOTE: This appliance must be installed in accordance with the manufacturer's instructions and the regulations in force. Read the instructions fully before installing or using the appliance.

"Benchmark" Log Book

As part of the industry-wide "Benchmark" initiative all Potterton boilers now include an Installation, Commissioning and Service Record Log Book. Please read the Log Book carefully and complete all sections relevant to the appliance and installation. These include sections on the type of controls employed, flushing the system, burner operating pressure etc. The details of the Log Book will be required in the event of any warranty work. Also, there is a section to be completed at each subsequent regular service visit. The Log Book must be left with the user.

1.2 Installation

1. The appliance is suitable for installation only in G.B. and I.E. and should be installed in accordance with the rules in force. For Ireland install in accordance with I.S.813 "INSTALLATION OF GAS APPLIANCES". The installation must be carried out by a CORGI Registered Installer or other competent person and be in accordance with the relevant requirements of **GAS SAFETY** (Installation and Use) **REGULATIONS**, the **BUILDING REGULATIONS** (Scotland) (Consolidation), the **LOCAL BUILDING REGULATIONS**, the **CURRENT I.E.E. WIRING REGULATIONS** and the bye laws of the Local Water Undertaking. Where no specific instructions are given, reference should be made to the relevant **BRITISH STANDARD CODES OF PRACTICE**.

1.3 Optional Extras

Various flue extensions, bends, vertical flue kits, control accessories etc. are available as optional extras. These are detailed in a separate publication

2.0 General Layout

2.1 Layout

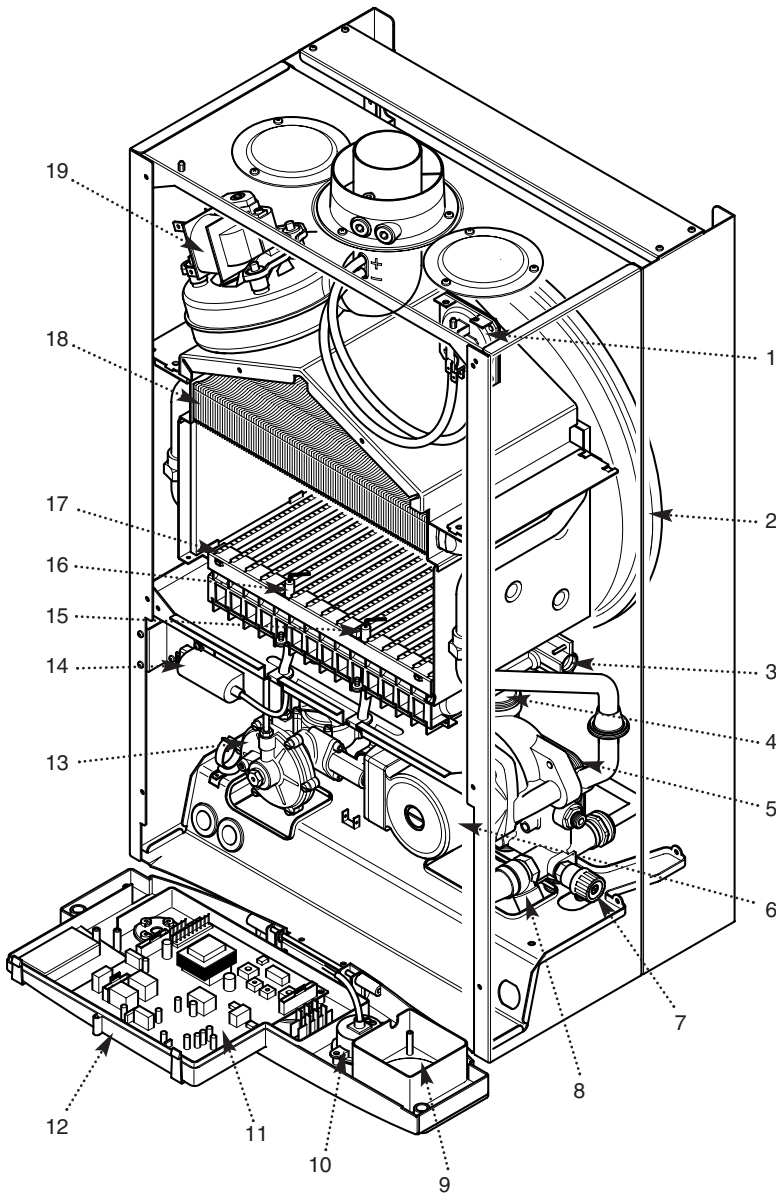

1. Air Pressure Switch
2. Expansion Vessel
3. Burner Manifold
4. Automatic Air Vent
5. DHW Plate Heat Exchanger
6. Circulation Pump
7. Drain Off Point
8. Pressure Relief Valve
9. Optional Integral Timer Position
10. Central Heating System Pressure Gauge
11. PCB
12. Control Box
13. 3-Way Valve Assembly
14. Spark Generator
15. Flame Sensing Electrode
16. Spark Electrode
17. Burner
18. Primary Heat Exchanger
19. Fan Assembly
20. On/Off/Reset Selector Switch
21. Central Heating Temperature Control
22. Hot Water Temperature Control
23. Flame Failure
24. Safety Thermostat
25. Fault on Fan or Flue
26. Fault on Pump or Low System Pressure
27. Fault on Hot Water Sensor
28. Fault on Central Heating Sensor
29. Power On
30. Domestic Hot Water Mode
31. Central Heating Mode
32. Burner On

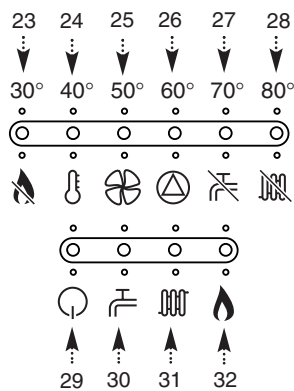

When neons 23 to 28 are constantly illuminated, they indicate the temperature of the central heating water.

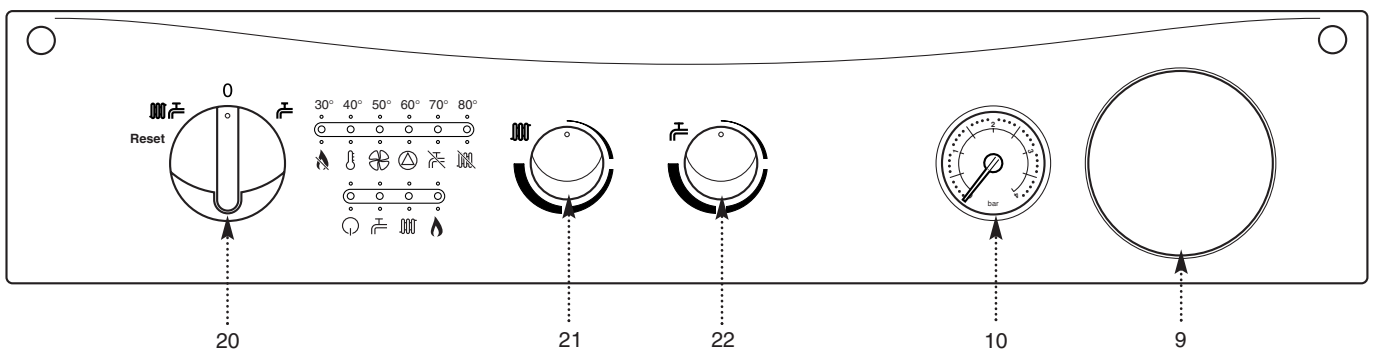

3.0 Appliance Operation

NOTE: All delay timers mentioned in 3.1 and 3.2 are overridden by domestic hot water demand.

3.1 Central Heating Mode (Fig. 2)

1. With a demand for heating, the pump circulates water through the primary circuit. At a pre-determined flow rate the central heating flow switch operates, initiating the ignition sequence.

2. The main burner ignites at low rate, then the gas valve controls the gas rate to maintain the heating temperature measured by the temperature sensor.

3. When the flow temperature exceeds the setting temperature, a 3 minute delay occurs before the burner relights automatically (anti-cycling). The pump continues to run during this period.

4. When the demand is satisfied the burner is extinguished and the pump continues to run for a period of 30 seconds (Pump Overrun).

3.2 Domestic Hot Water Mode (Fig. 3)

1. Priority is given to the domestic hot water supply. A demand at a tap or shower will override any central heating requirement.

2. The flow of water will operate the DHW flow switch which requests the 3 way valve to change position. This will allow the pump to circulate the primary water through the DHW plate heat exchanger.

3. The burner will light automatically and the temperature of the domestic hot water is controlled by the temperature sensor.

4. When the domestic hot water demand ceases the burner will extinguish and the diverter valve will remain in the domestic hot water mode, unless there is a demand for central heating.

IMPORTANT: When the selector switch is in the '0' (Off) position the electrical supply to the boiler is isolated. The boiler will not operate and the integral timer (if fitted) will require resetting once the selector switch is set to either Position (i) or Position (ii).

3.3 Frost Protection Mode

1. The frost protection mode is integral to the appliance and functions only with the selector switch (see Section 2.1). If the system temperature falls below 5° C then the boiler will fire on its minimum setting until a flow temperature of 30° C is reached. Further protection can be incorporated by using a system frost thermostat.

3.4 Pump Protection

1. With the selector switch (see Section 2.1) in either the central heating or central heating and domestic hot water position, the pump will automatically operate for 1 minute in every 24 hours to prevent sticking.

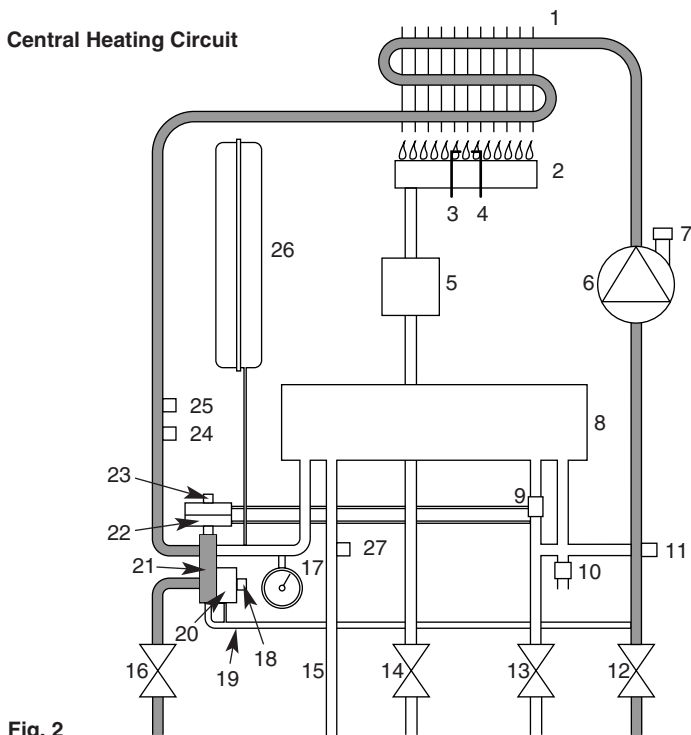

Fig. 2

Key

1 Primary Heat Exchanger	14 Gas Inlet
2 Burner	15 Domestic Hot Water Outlet
3 Ignition Electrode	16 Heating Flow
4 Flame Sensing Electrode	17 Pressure Gauge
5 Gas Valve	18 Hydraulic Differential Pressure Sensor Microswitch
6 Pump	19 Automatic By-Pass
7 Automatic Air Vent	20 Hydraulic Differential Pressure Sensor
8 Plate Heat Exchanger	21 Diverter Valve Assembly
9 Flow Sensor with Filter	22 Domestic Hot Water Flow Priority Assembly
10 Pressure Relief Valve	23 Domestic Hot Water Flow Priority Microswitch
11 Boiler Drain Point	24 Safety Thermostat
12 Heating Return	25 Central Heating Temperature Sensor
13 Cold Water Inlet On/Off Valve and Filter	26 Expansion Vessel
	27 Domestic Hot Water Temperature Sensor

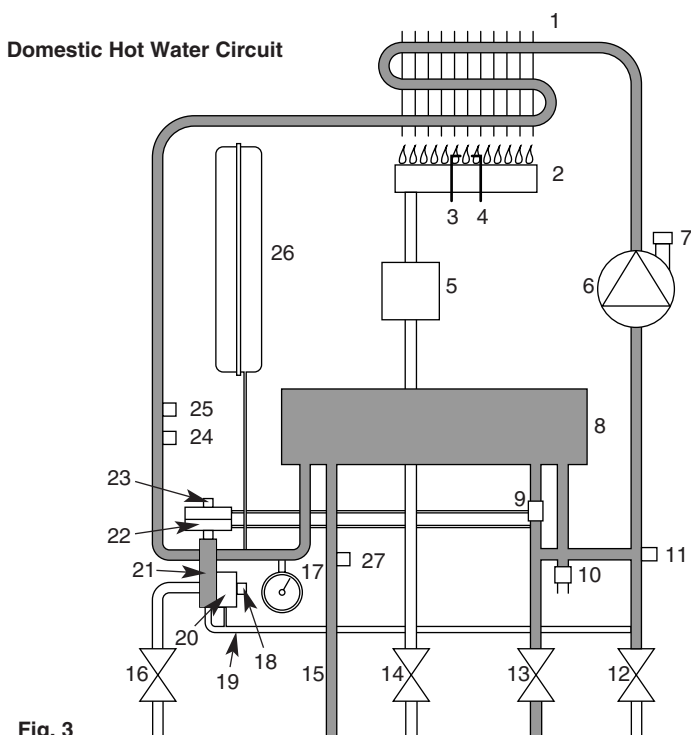

Fig. 3

4.0 Technical Data

4.1 Performa 28

Appliance Type	C ₁₂	C ₃₂
Appliance Category	CAT II 2H 3P	
Heat Input C/H & DHW (Gross)		
	Max	Min
kW	32.6	11.9
Btu/h	111,250	40,610
Heat Output		
	Max	Min
kW	29.4	10.4
Btu/h	100,330	35,490
Max Gas Rate (Natural Gas - G20) (After 10 Mins)		
m ³ /h	3.45	
ft ³ /h	122	
Burner Pressure (Natural Gas - G20)		
	Max Rate	Min Rate
mbar	12.5 ± 0.5	1.8 ± 0.2
in wg	5.0 ± 0.2	0.72 ± 0.2
Inlet Pressure (Natural Gas - G20)		
mbar	20	
in wg	8	
Burner Injector (Natural Gas - G20) 15 x 1.28mm Diameter		
Electrical Supply 230V~ 50Hz (Appliance must be connected to an earthed supply)		
Power Consumption	190W	
External Fuse Rating	3A	
Internal Fuse Rating Fuse 2A Fast Blow to BS 4265		
Electrical Protection IPX5D		

Nox Class	3	
Flue Terminal Dimensions		
Diameter	100mm	
Projection	95mm	
Connections		
	copper tails	
Gas Supply	- 22mm	
Central Heating Flow	- 22mm	
Central Heating Return	- 22mm	
Cold Water Mains Inlet	- 15mm	
DHW Flow	- 15mm	
Pressure Relief Discharge	- 15mm	
Outercase Dimensions		
Casing Height	- 780mm	
Overall Height Inc Flue		
Elbow	- 980mm	
Casing Width	- 450mm	
Casing Depth	- 345mm	
Clearances		
Both Sides	5 mm Min	
Above Casing	200 mm Min	
Below Casing	200 mm Min	
Front	450 mm Min (For Servicing)	
Front	5 mm Min (In Operation)	
Weights		
	kg	
Packaged Boiler Carton	49	
Packaged Flue Kit	3	
Installation Lift Weight	41	
Central Heating Primary Circuit Pressures		
	bar	
Safety Discharge	3	
Max Operating	2.5	
Min Operating	0.5	
Recommend Operating	1-2	
Recommended System Temperature Drop		
	11°C	20°F

DHW Circuit Pressures	bar
Max Operating	8
Min Operating	0.2
Min Operating Pressure at 12.7 l/min	0.96
Flow Rates l/min	
DHW Flow Rate @ 30°C Rise	13.9
DHW Flow Rate @ 35°C Rise	12.0
Min Working DHW Flow Rate	2.5
Pump	
Available Head	See graph below
Expansion Vessel - (For Central Heating only. Integral with appliance)	
	bar
Min Pre-charge Pressure	0.5
	litre
Max Capacity of CH System	125
Primary Water Content of Boiler (unpressurised)	1.2
Temperatures	
C.H. Flow Temp (adjustable)	35°C to 85°C max (± 5°C)
D.H.W. Flow Temp (adjustable)	35°C to 65°C max (± 5°C) dependent upon flow rate

SEDBUK Declaration

The seasonal efficiency (SEDBUK) is 78.2 %

This value is used in the UK Government's Standard Assessment Procedure (SAP) for energy rating of dwellings. The test data from which it has been calculated have been certified by 0051.

LPG Propane - G31			
Burner Injector 15 x 0.77mm diameter			
Burner Pressure	Max Rate	Min Rate	
Propane	mbar	34.4	5.1
	in wg	13.8	2.0
Inlet Pressures			
	mbar	37	
	in wg	14.8	

Pump - Available Head

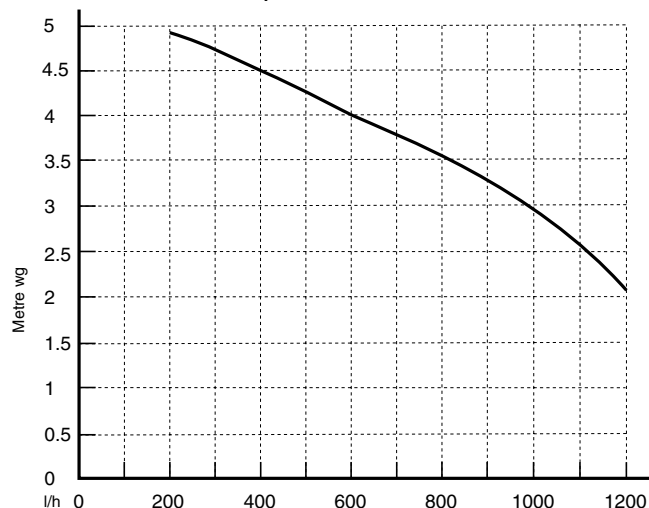

5.0 Dimensions and Fixings

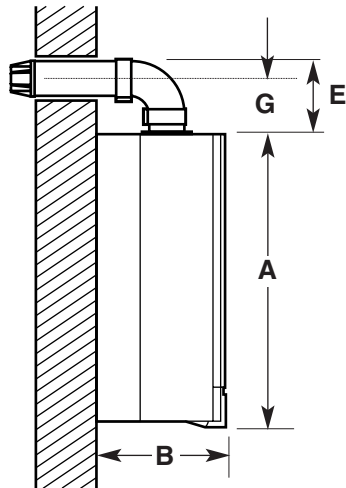

Dimensions

A 780mm

B 345mm

C 450mm

D 107mm Ø Min.

E 200mm

F 190mm

G 143mm

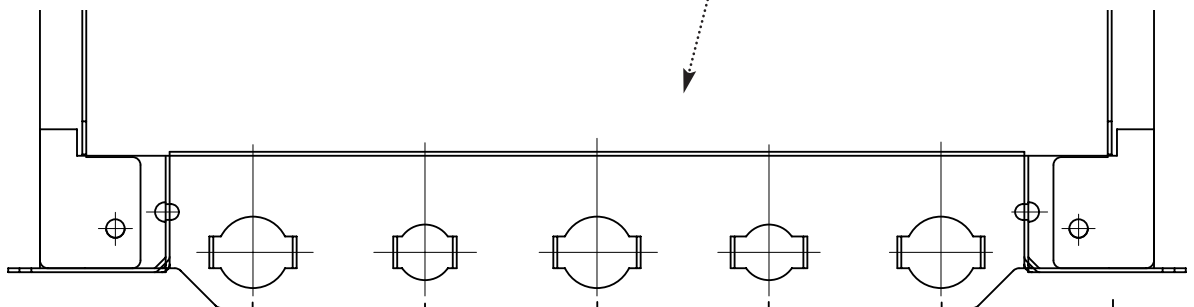
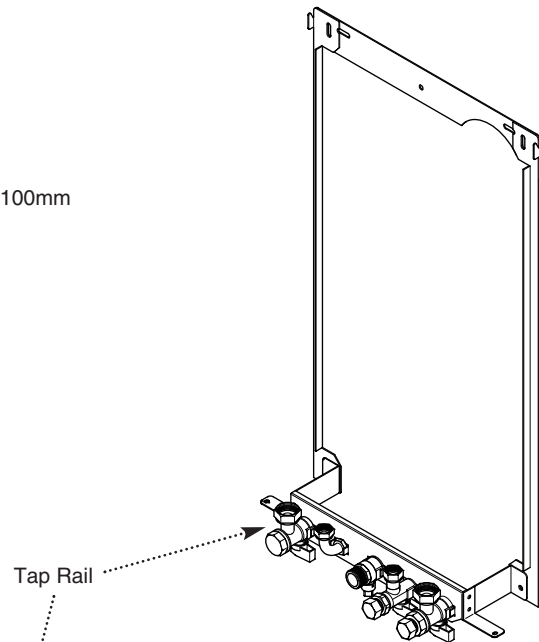
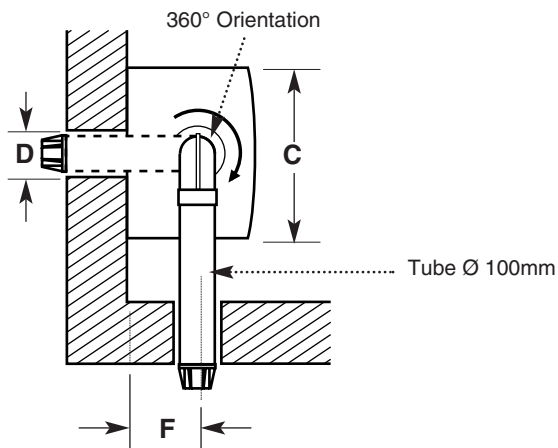

65 mm 65 mm 65 mm 65 mm 65 mm

Heating Flow (22mm) Domestic Hot Water Outlet (15mm) Gas Inlet (22mm) Cold Water Inlet (15mm) Heating Return (22mm) Pressure Relief Valve (15mm)



6.0 System Details

6.1 Information

1. The Potterton Performa 28 Combination Boiler is a 'Water Byelaws Scheme - Approved Product'. To comply with the Water Byelaws your attention is drawn to the following installation requirements and notes (IRN).

- a) IRN 001 - See text of entry for installation requirements and notes.
- b) IRN 116 - Byelaw 90 and 91.
- c) IRN 302 - Byelaw 14.

2. Reference to the WRc publications, 'Water fittings and materials directory' and 'Water supply byelaws guide' give full details of byelaws and the IRNs.

6.2 Central Heating Circuit

1. The appliance is suitable for fully pumped SEALED SYSTEMS ONLY.

Treatment of Water Circulating Systems

- All recirculatory water systems will be subject to corrosion unless an appropriate water treatment is applied. This means that the efficiency of the system will deteriorate as corrosion sludge accumulates within the system, risking damage to pump and valves, boiler noise and circulation problems.
- For optimum performance after installation this boiler and its associated central heating system must be flushed in accordance with the guidelines given in BS 7593 "Treatment of water in domestic hot water central heating systems".
- This must involve the use of a proprietary cleanser, such as BetzDearborn Sentinel X300 or X400, or Fernox Superfloc. Full instructions are supplied with the products, but for immediate information please contact BetzDearborn (0151 420 9563) or Fernox (01799 550 811) directly.
- For long term protection against corrosion and scale, after flushing it is recommended that an inhibitor such as BetzDearborn Sentinel X100, or Fernox MB-1 or Copal is dosed in accordance with the guidelines given in BS 7593.

Failure to flush and add inhibitor to the system may invalidate the appliance warranty.

- It is important to check the inhibitor concentration after installation, system modification and at every service in accordance with the manufacturer's instructions. (Test kits are available from inhibitor stockists.)
-

6.3 Bypass

1. The boiler is fitted with an automatic integral bypass.

6.4 System Control

1. The boiler is designed for use in a heating system that incorporates external controls, i.e. a minimum of a timer device.

2. Suitable timer kits are available as optional extras.

3. For optimum operating conditions and maximum economy the fitting of a programmable room thermostat is recommended.

6.0 System Details

6.5 System Filling and Pressurising

1. A filling point connection on the central heating return pipework must be provided to facilitate initial filling and pressurising and also any subsequent water loss replacement/refilling.

2. The filling method adopted must be in accordance with all relevant water supply by-laws and use approved equipment.

3. Your attention is drawn to: IRN 302 and Byelaw 14.

4. The sealed primary circuits may be filled or replenished by means of a temporary connection between the circuit and a supply pipe, provided a 'Listed' double check valve or some other no less effective backflow prevention device is permanently connected at the inlet to the circuit and the temporary connection is removed after use (Fig. 4).

5. There are connection points on the mains cold water inlet and central heating return isolating taps, (Fig 4a) to which the optional filling loop (Part No. 248221) can be assembled.

6.6 Expansion Vessel (Central Heating only)

1. The appliance expansion vessel is pre-charged to 0.5 bar. Therefore, the minimum cold fill pressure is 0.5 bar. The vessel is suitable for correct operation for system capacities up to 125 litres. For greater system capacities an additional expansion vessel must be fitted - refer to BS 7074 Pt 1.

6.7 Pressure Relief Valve (Fig. 5)

1. The pressure relief valve is set at 3 bar, therefore all pipework, fittings, etc. should be suitable for pressures in excess of 3 bar.

2. The pressure relief discharge pipe should be not less than 15mm dia, run continuously downward, and discharge outside the building, preferably over a drain. It should be routed in such a manner that no hazard occurs to occupants or causes damage to wiring or electrical components. The end of the pipe should terminate facing down and towards the wall.

3. The discharge must not be above a window, entrance or other public access. Consideration must be given to the possibility that boiling water/steam could discharge from the pipe.

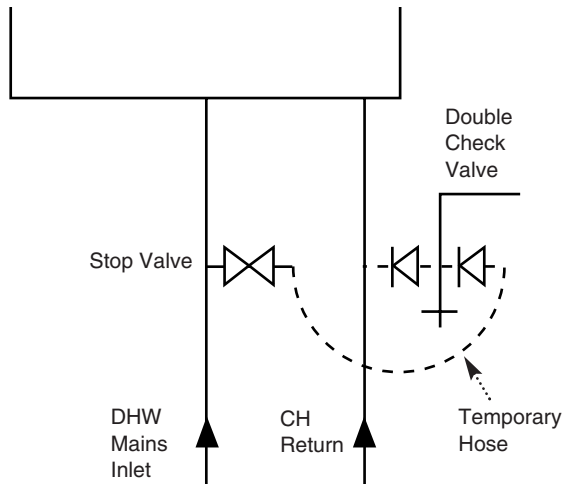
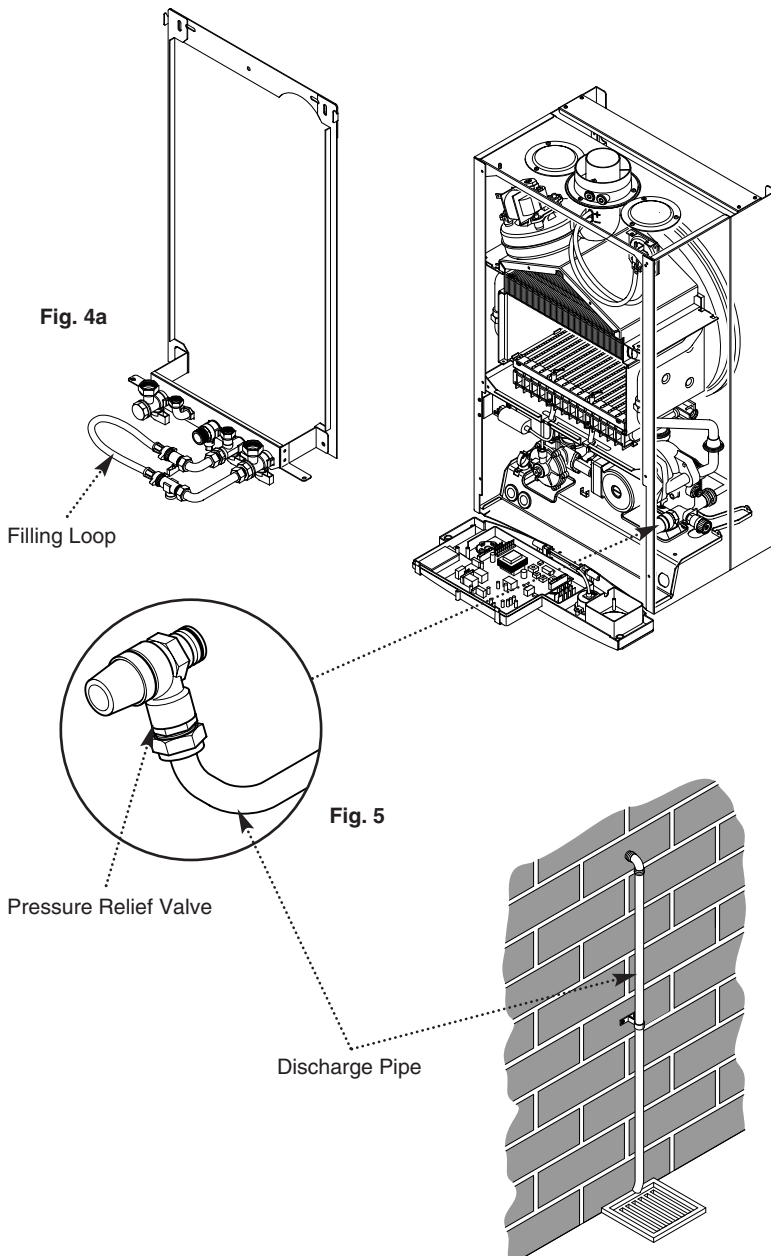

Fig. 4



6.0 System Details

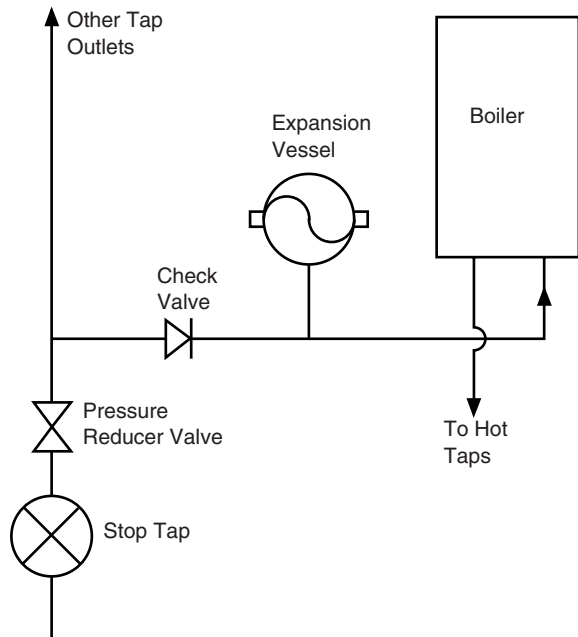

Fig. 6

6.8 Domestic Hot Water Circuit (Fig. 6)

1. All DHW circuits, connections, fittings, etc. should be fully in accordance with relevant standards and water supply bye-laws.

2. Your attention is drawn to:

IRN 116 and Byelaw 90 and 91.

Sealed primary circuits and/or secondary hot water systems shall incorporate a means for accommodating the thermal expansion of water to prevent any discharge from the circuit and/or system, except in an emergency situation.

3. When the system includes any device which prevents water expanding back towards the supply (check valve, loose jumpered stopcock, water meter, water treatment device), then an expansion vessel must be fitted (e.g. Zilmet 160ml, R¹/₂ 15bar). To comply with Byelaw 91, a check valve must also be fitted on the supply as shown, to ensure efficient operation and also to prevent the reverse flow of hot water into the supply pipe.

4. If the hot water expansion is not provided for, then high pressures can develop which may result in damage to fittings and devices on the system.

5. The boiler's maximum working mains pressure is 8 bar, therefore all pipework, connections, fittings, etc. should be suitable for pressures in excess of 10 bar. A pressure reducing valve must be fitted for pressures in excess of 10 bar. The manufacturer of any outlet fittings, such as a shower valve, may require a lower maximum pressure. The pressure reduction must take account of all fittings connected to the DHW system.

6.9 Showers

1. If a shower control is supplied from the appliance it should be of the thermostatic or pressure balanced type. Thermostatic type shower valves provide the best comfort and guard against water at too high a temperature. Existing controls may not be suitable - refer to the shower valve manufacturer.

6.10 Hard Water Areas

1. If the area of the installation is recognised as a HARD WATER AREA then a suitable device should be fitted to treat the mains water supply to the boiler.

7.0 Site Requirements

7.1 Information

1. The installation must be carried out by a CORGI Registered Installer or other registered competent person and be in accordance with the relevant requirements of the current **Gas Safety** (Installation and Use) **REGULATIONS**, the **BUILDING REGULATIONS** (Scotland)(Consolidation), the **LOCAL BUILDING REGULATIONS**, the current **I.E.E. WIRING REGULATIONS** and the bye laws of the **LOCAL WATER UNDERTAKING**. Where no specific instruction is given reference should be made to the relevant **BRITISH STANDARD CODES OF PRACTICE**. For Ireland install in accordance with IS 813 "INSTALLATION OF GAS APPLIANCES".

7.2 B.S. Codes of Practice

Standard	Scope
BS 6891	Gas Installation.
BS 5546	Installation of hot water supplies for domestic purposes.
BS 5449 Part 1	Forced circulation hot water systems.
BS 6798	Installation of gas fired hot water boilers.
BS 5440 Part 1	Flues.
BS 5440 Part 2	Ventilation.
BS 7074	Expansion vessels and ancillary equipment for sealed water systems.
BS 7593	Treatment of water in domestic hot water central heating systems.

WARNING - The addition of anything that may interfere with the normal operation of the appliance without express written permission could invalidate the appliance warranty and infringe the **Gas Safety** (Installation and Use) **REGULATIONS**.

7.3 Clearances (Figs. 7 & 8)

1. A flat vertical area is required for the installation of the boiler.
2. These dimensions include the necessary clearances around the boiler for case removal, spanner access and air movement. Additional clearances may be required for the passage of pipes around local obstructions such as joists running parallel to the front face of the boiler.

7.4 Location

1. The boiler may be fitted to any suitable wall with the flue passing through an outside wall or roof and discharging to atmosphere in a position permitting satisfactory removal of combustion products and providing an adequate air supply. The boiler should be fitted within the building unless otherwise protected by a suitable enclosure i.e. garage or outhouse. (The boiler may be fitted inside a cupboard-see Section 7.5).
2. If the boiler is sited in an unheated enclosure then it is recommended to leave the ON/OFF Selector Switch in the domestic hot water and central heating position to give frost protection.
3. If the boiler is fitted in a room containing a bath or shower reference must be made to the current **I.E.E. WIRING REGULATIONS** and **BUILDING REGULATIONS**. If the boiler is to be fitted into a building of timber frame construction then reference must be made to the current edition of Institute of Gas Engineers Publication IGE/UP/7 (Gas Installations in Timber Framed Housing).

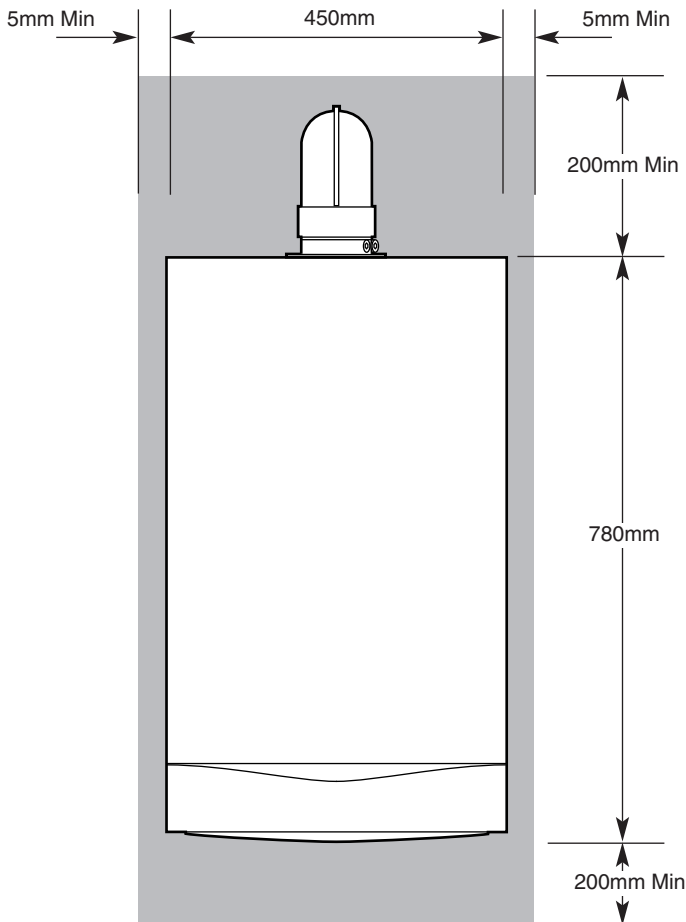

Fig. 7

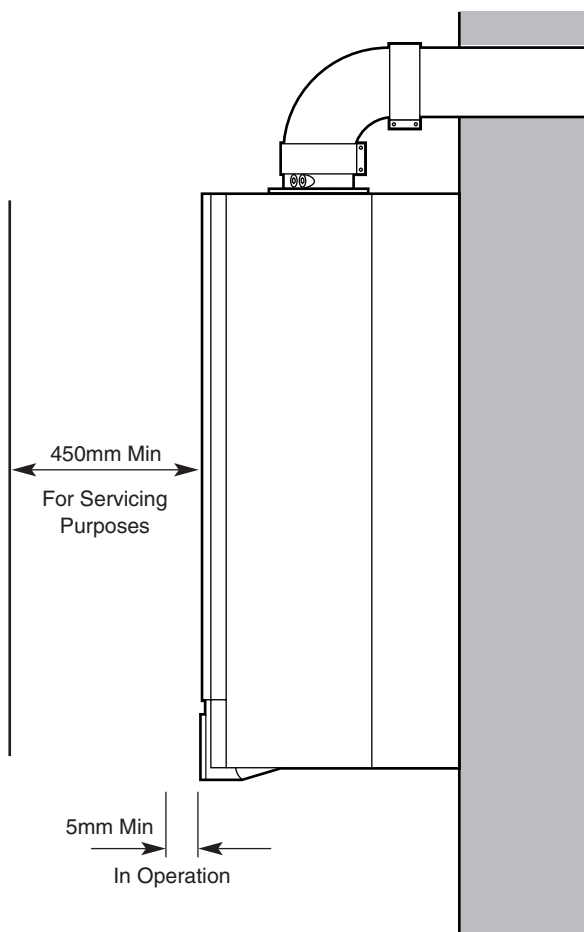

Fig. 8

7.0 Site Requirements

7.5 Ventilation of Compartments

1. Where the appliance is installed in a cupboard or compartment, no air vents are required.
2. BS 5440: Part 2 Clause 4.2 refers to room sealed appliances installed in compartments. The appliance will run sufficiently cool without ventilation.

7.6 Gas Supply

1. The gas installation should be in accordance with BS6891.
2. The connection to the appliance is a 22mm copper tail located at the rear of the gas service cock (Fig. 9).
3. Ensure that the pipework from the meter to the appliance is of adequate size. Do not use pipes of a smaller diameter than the boiler gas connection (22mm).

7.7 Electrical Supply

1. External wiring must be correctly earthed, polarised and in accordance with current **I.E.E. WIRING REGULATIONS**.
2. The mains supply is 230V ~ 50Hz fused at 3A.

NOTE: The method of connection to the electricity supply must facilitate complete electrical isolation of the appliance.

Connection may be via a fused double-pole isolator with a contact separation of at least 3mm in all poles and servicing the boiler and system controls only.

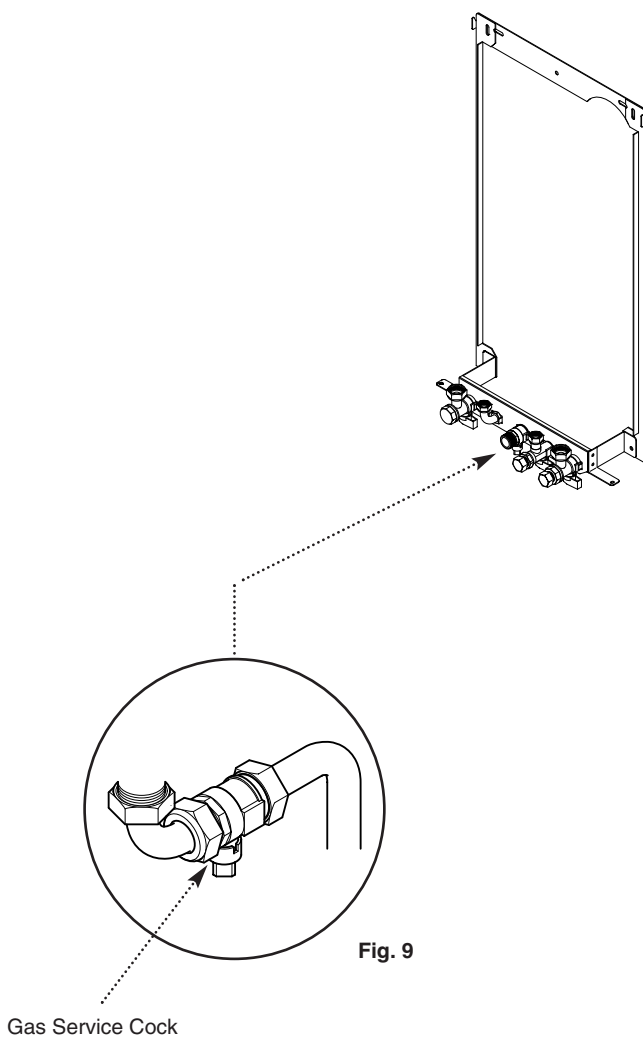

7.0 Site Requirements

7.8 Flue

1. An internal fitting kit is available for installations where the flue terminal is inaccessible from the outside. Quote Part N° 236441BAX when ordering.

2. The following guidelines indicate the general requirements for siting balanced flue terminals. Recommendations for flues are given in BS 5440 Pt.1.

3. If the terminal is fitted within 1 metre of a plastic gutter, within 500mm of a painted eave or a painted gutter, an aluminium shield of at least 1 metre long should be fitted to the underside of the gutter or painted surface. An air space of 5mm should be left between shield and gutter (Fig. 10).

4. If the terminal discharges onto a pathway or passageway, check that combustion products will not cause a nuisance and that the terminal will not obstruct the passageway.

5. If a terminal is less than 2 metres above a balcony, above ground or above a flat roof to which people have access, then a suitable terminal guard must be provided.

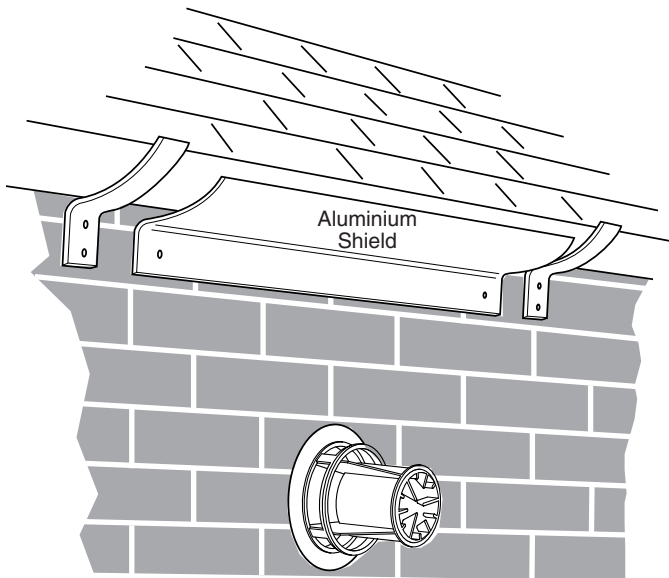

Fig. 10

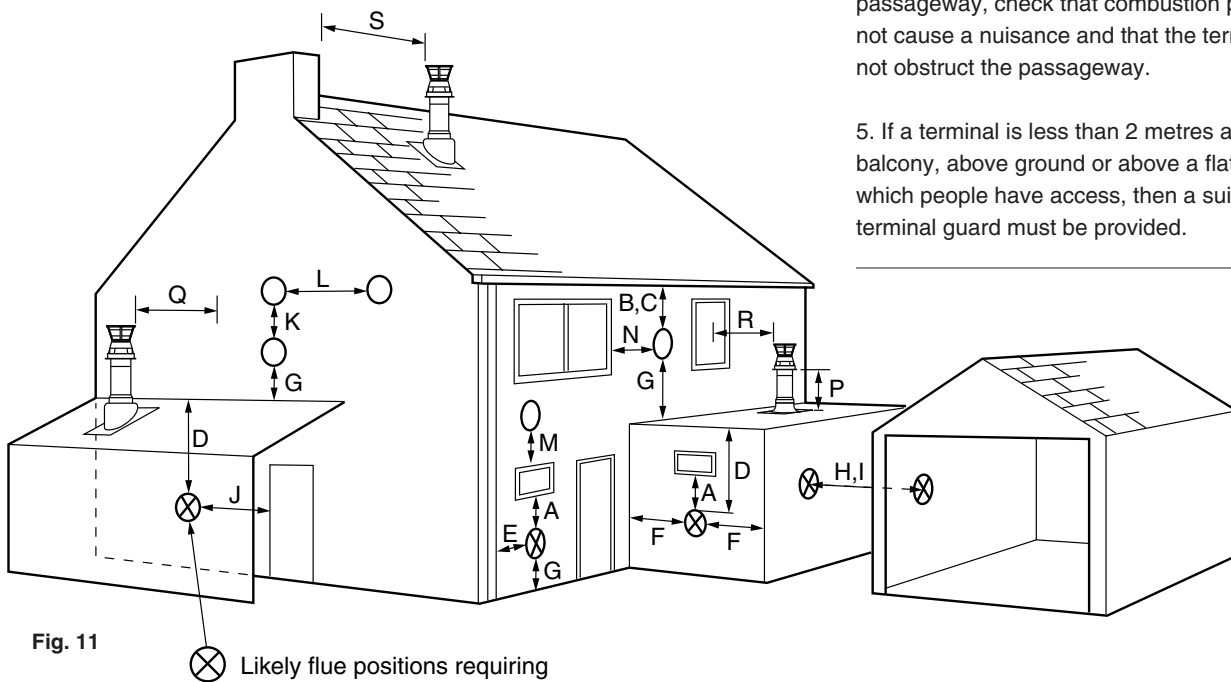

Fig. 11

⊗ Likely flue positions requiring a flue terminal guard

Terminal Position with Minimum Distance (Fig. 11) (mm)

A	Directly below an openable window, air vent or any other ventilation opening.	300
B	Below gutter, drain/soil pipe.	75
C	Below eaves.	200
D	Below a balcony/car port roof.	200
E	From vertical drain pipes and soil pipes.	75
F	From internal or external corners.	300
G	Above adjacent ground or balcony level.	300
H	From a surface facing a terminal.	600
I	Facing a terminals.	1200
J	From opening (door/window) in carport into dwelling.	1200
K	Vertically from a terminal on the same wall.	1500
L	Horizontally from a terminal on the same wall.	300
M	Above an opening, air brick, opening window etc.	300
N	Horizontally to an opening, air brick, opening window etc.	300

Vertical Flues - minimum distance to edge of terminal mm

P	Above the roof level (to base of terminal).	300
Q	From adjacent wall to flue.	300
R	From adjacent opening window.	1000
S	From another terminal.	600

7.0 Site Requirements

7.9 Flue Dimensions

The standard horizontal flue kit allows for flue lengths between 100mm and 1m from elbow to terminal (Fig. 12).

The maximum permissible equivalent flue length is: 4 metres

NOTE: Each additional 45° of flue bend will account for an equivalent flue length of 0.5m.
eg. 45° = 0.5m, 90° = 2 x 45° = 1m etc.

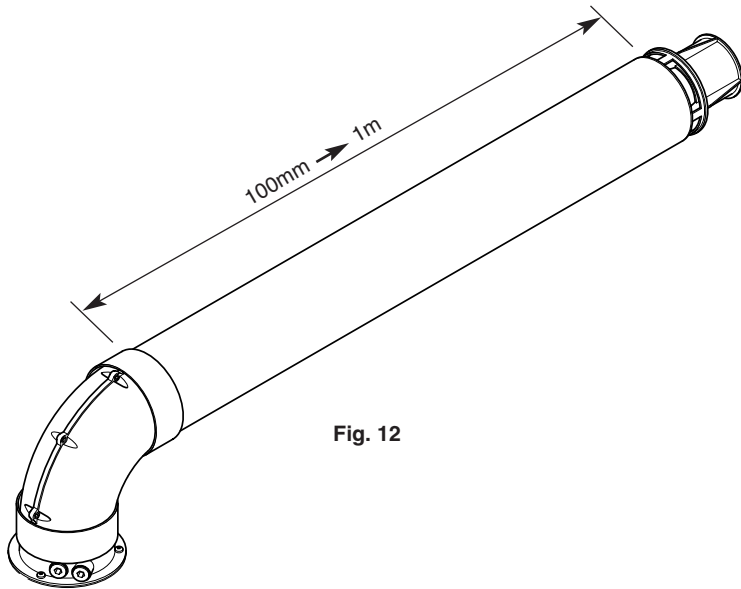

Fig. 12

7.10 Flue Terminal Trim

1. Once the flue is secure the trim can be fitted if required.

2. Remove the protective backing from the adhesive seal. Apply the seal to the rear of the trim flange (Fig. 13).

3. Locate the trim over the flue terminal and push it back to the wall to compress the seal (Fig. 14).

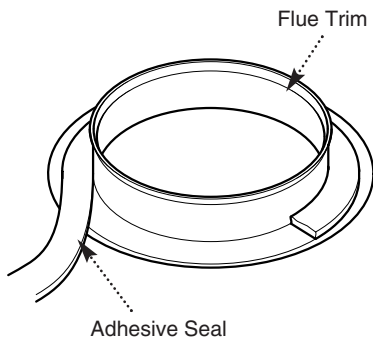

Fig. 13

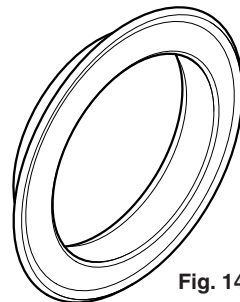

Fig. 14

7.11 Terminal Guard (Fig. 15)

1. When codes of practice dictate the use of terminal guards, they can be obtained from most Plumbers' and Builders' Merchants.

2. There must be a clearance of at least 50mm between any part of the terminal and the guard.

3. When ordering a terminal guard, quote the appliance name and model number.

4. The flue terminal guard should be positioned centrally over the terminal and fixed as illustrated.

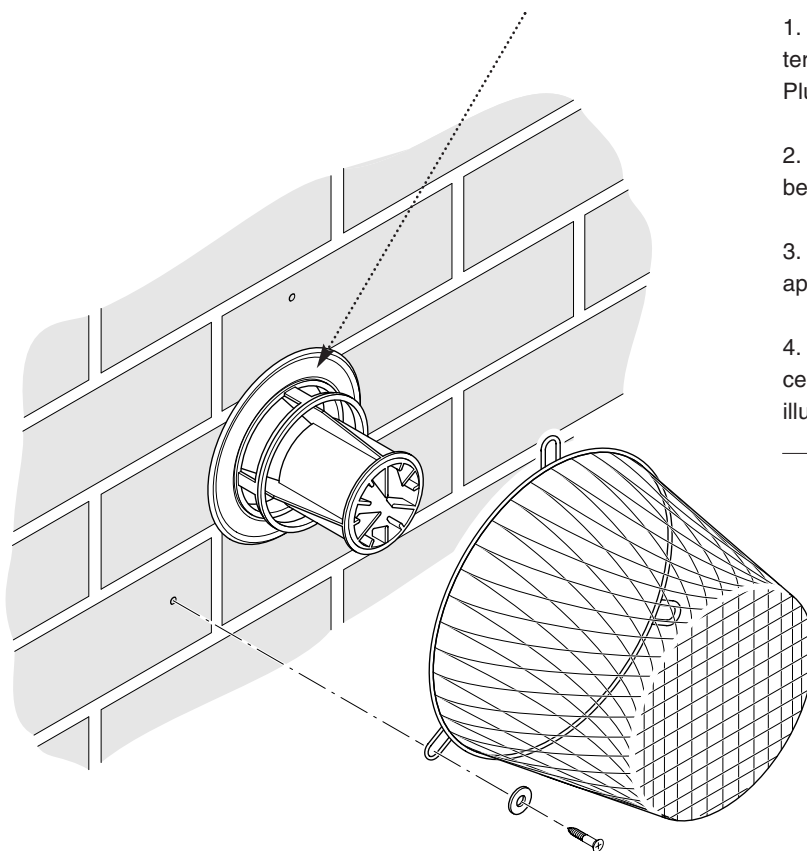

Fig. 15

7.0 Site Requirements

7.12 Flue Options

1. The Potterton Performa 28 can be fitted with flue systems as illustrated.
2. The standard flue is suitable only for horizontal applications.

3. Maximum permissible equivalent flue lengths are:-

Concentric	4m
Vertical	4m
Vertical Two-Pipe	12m

4. Any additional "in line" bends in the flue system must be taken into consideration.

Their equivalent lengths are:-

Concentric Pipes:

45° bend	0.5 metres
90° bend	1.0 metres

Twin Flue Pipe

45° bend	0.25 metres
90° bend	0.50 metres

The elbow supplied with the standard horizontal flue is not included in any equivalent length calculations

5. The illustrations opposite show examples of maximum equivalent lengths.

6. Instructions for guidance and fitting are included in each kit where appropriate.

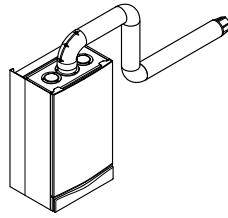
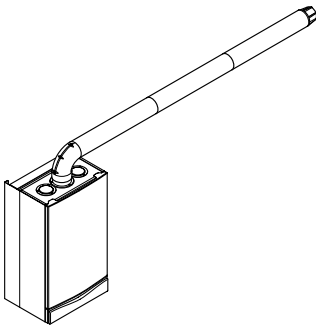

Maximum Length = 3m inc. 2 x 45° bends

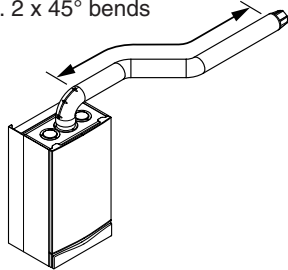

Horizontal Flues

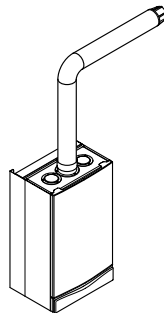
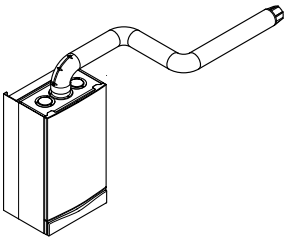

Vertical Flues (Twin Pipe)

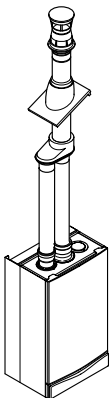

Maximum Length = 11m
inc. 4 x 45° bends

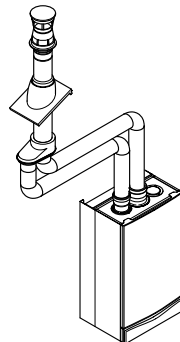
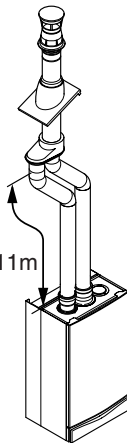

Vertical Flues

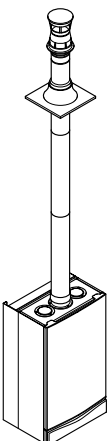

Maximum Length = 2m
inc. 2 x 90° bends

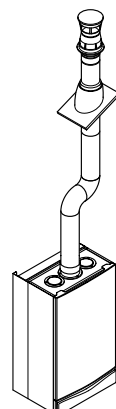
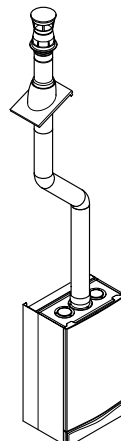
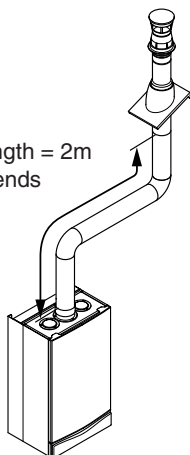

Fixing Template

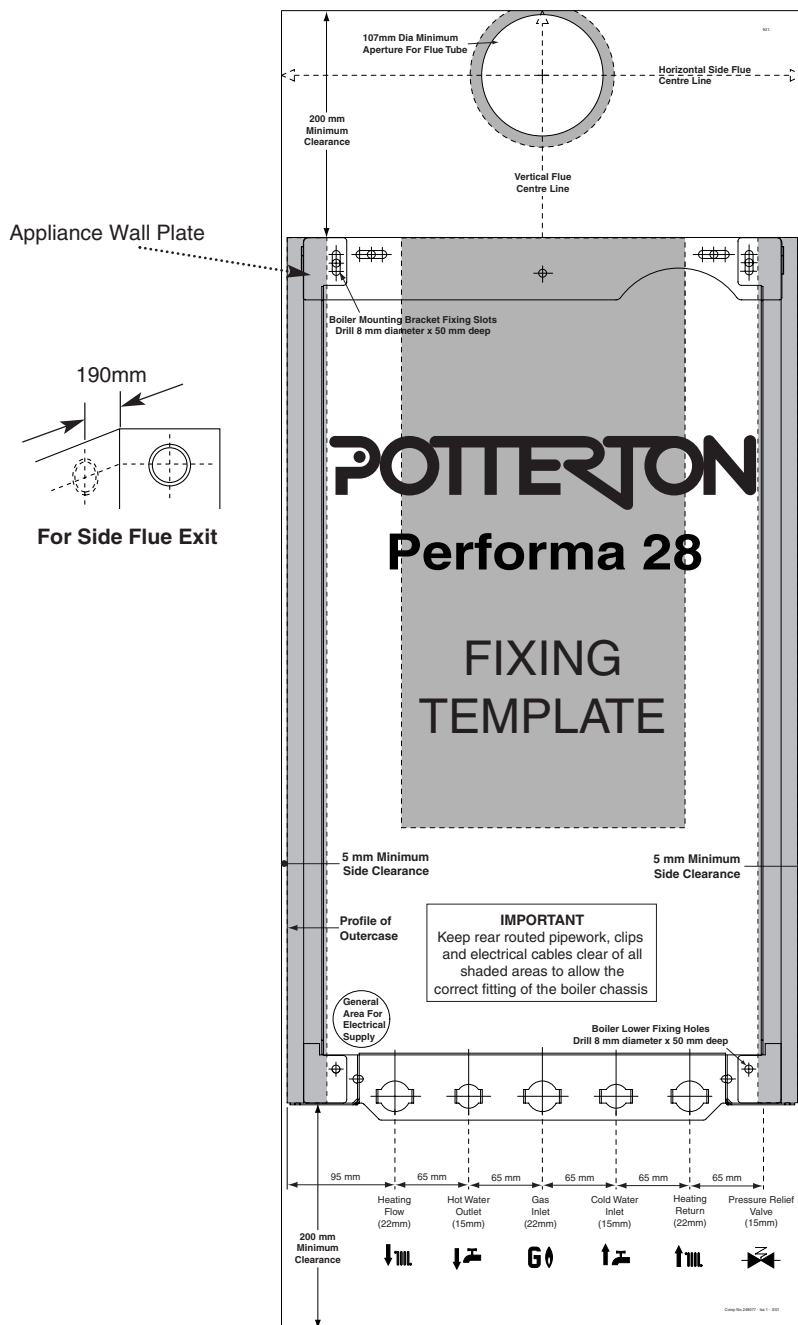

Fig. 16

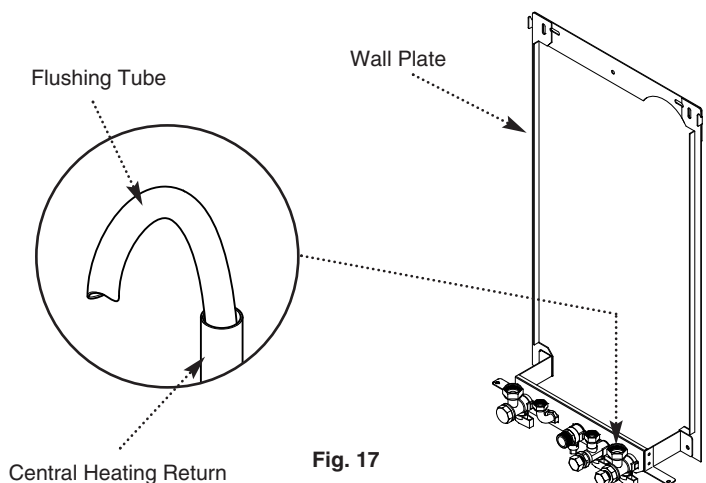

Fig. 17

8.0 Installation

8.1 Initial Preparation

The gas supply, gas type and pressure must be checked for suitability before connection (see Section 7.6).

1. After considering the site requirements (see Section 7.0) position the fixing template (Fig. 16) on the wall ensuring it is level both horizontally and vertically.
2. Mark the position of the two most suitable fixing slots for the wall plate and boiler lower fixing holes. It is preferable to use the horizontal fixing slots.
3. Mark the position of the centre of the flue hole (rear exit). For side flue exit, mark as shown.
4. Note the shaded area on the template. Pipework may be routed upwards behind the boiler, providing it does not conflict with the shaded area.
5. If required, mark the position of the gas and water pipes. Remove the template.
6. Cut the hole for the flue (minimum diameter 107mm).
7. Drill the wall as previously marked to accept the wall plugs supplied. Secure the wall plate using the fixing screws.
8. Using a spirit level ensure that the plate is level before finally tightening the screws.
9. Connect the gas and water pipes to the valves on the wall plate using the copper tails supplied. Ensure that the sealing washers are fitted between the connections.

8.2 Flushing

1. Connect a tube to the central heating flow or return pipe (Fig. 17).
2. Flush thoroughly (see System Details, Section 6.2).

8.3 Preparing The Boiler

1. Remove all packaging.
2. Stand the boiler on its base by using the rear lower edge as a pivot.

NOTE: A small amount of water may drain from the boiler in the upright position.

Potterton declare that no substances harmful to health are contained in the appliance or used during construction of the appliance.

8.0 Installation

8.4 Fitting The Boiler

1. Remove the sealing caps from the boiler connections.
2. Lift the boiler using the lower edges. Engage the slots at the top rear of the boiler on the wall plate (Fig. 18).
3. Insert the sealing washers between the valves and pipes on the wall plate and the boiler connections. **The rubber washers must be used on the gas connection.**
4. Tighten all the connections.
5. Secure the boiler side panels to the boiler wall plate flanges using the screws provided (Fig. 18).

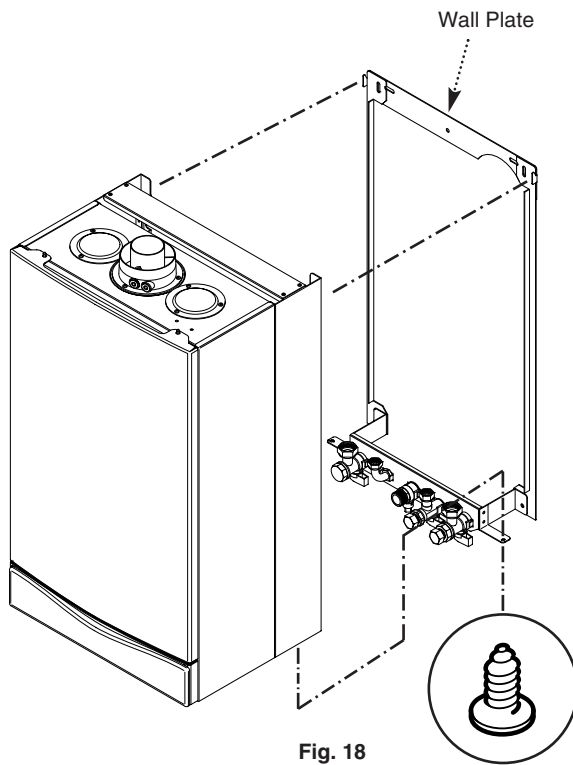

8.5 Fitting the Pressure Relief Discharge Pipe (Fig. 19)

1. Remove the discharge pipe from the kit.
2. Determine the routing of the discharge pipe in the vicinity of the boiler. Make up as much of the pipework as is practical, including the discharge pipe supplied.
3. The pipework must be at least 15mm diameter and run continuously downwards to a discharge point outside the building. See section 6.7 for further details.
4. Utilising one of the sealing washers, connect the discharge pipe to the adaptor and tighten the nut.
5. Complete the discharge pipework and route it to the outside discharge point.

IMPORTANT: Make all soldered joints before connecting to the pressure relief valve.

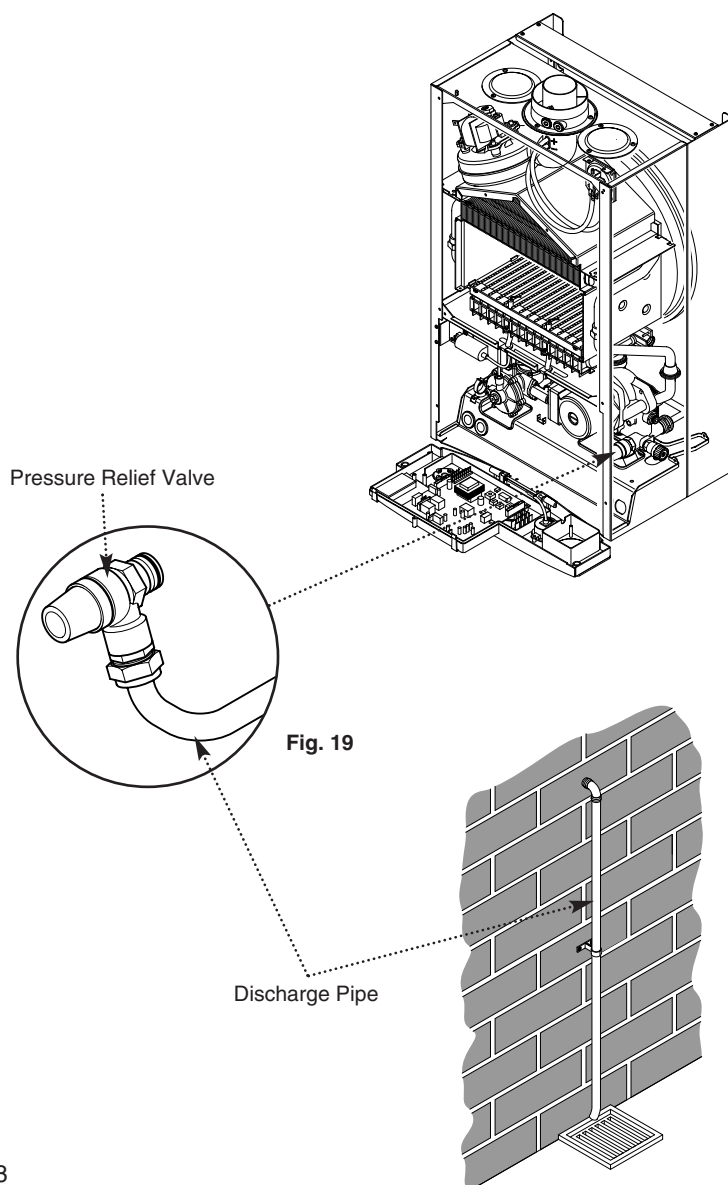

8.0 Installation

8.6 Fitting The Flue

HORIZONTAL FLUE

1. The standard flue is suitable for lengths 100mm minimum to 1m maximum (measured from the edge of the flue elbow outlet).

Rear Flue: maximum wall thickness - 900mm

Side Flue: maximum wall thickness - 870mm

2. If using the optional internal fitting kit, flue extension kit or elbows, refer to the instructions provided with the kits.

3. Locate the flue elbow on the adaptor at the top of the boiler. Set the elbow to the required orientation (rear, right or left).

4. Measure the distance from the outside wall face to the elbow (Fig. 20). This dimension will be known as 'X'.

5. Taking the air duct, mark dimension 'X' as shown (Fig. 21). Measure the length of waste material, and transfer the dimension to the flue duct (Fig. 21).

6. Remove the waste from both ducts. Ensure that the cut ends are square and free from burrs.

7. Remove the flue elbow from the adaptor.

IMPORTANT: Check all measurements before cutting.

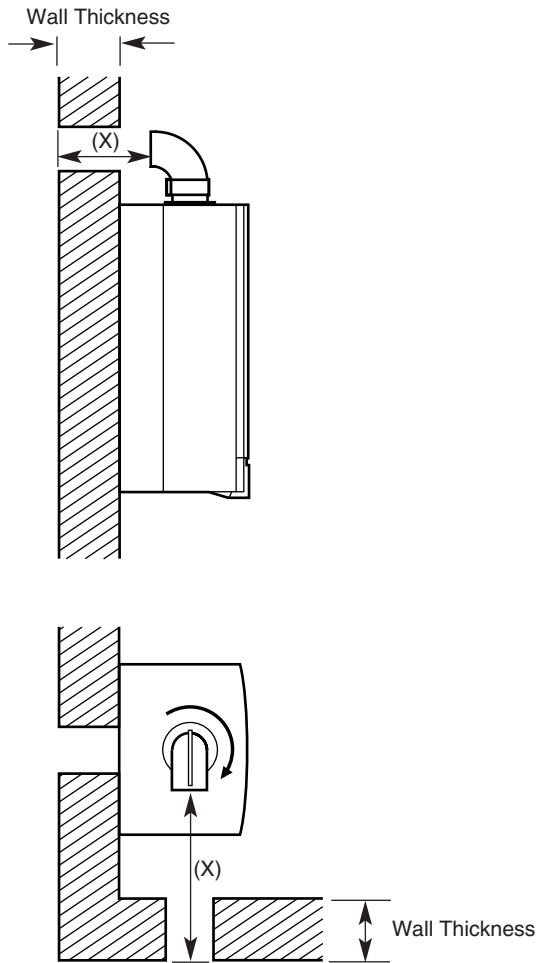

Fig. 20

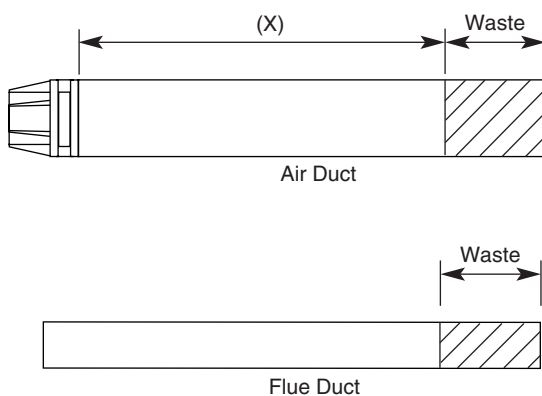

Fig. 21

8.0 Installation

8.6 Fitting the Flue (Cont)

IMPORTANT: If the equivalent flue length is greater than 1.5m the restrictor **MUST** be removed from the adaptor (Fig. 22).

Fig. 22

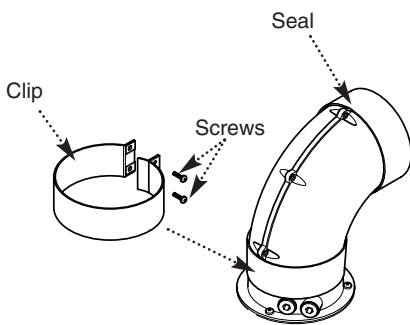
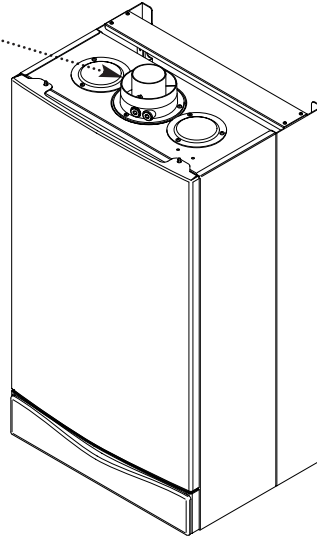
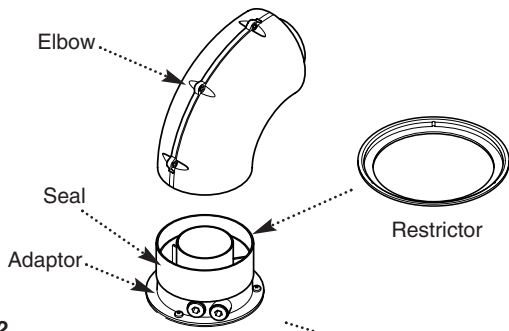

Fig. 23

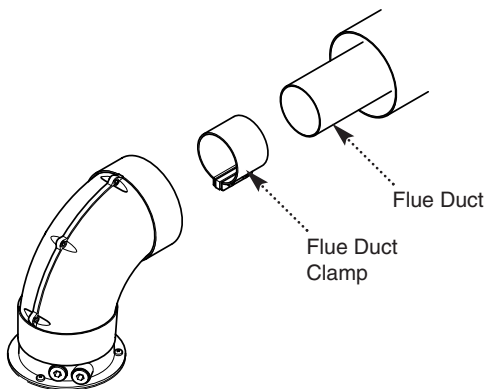

Fig. 24

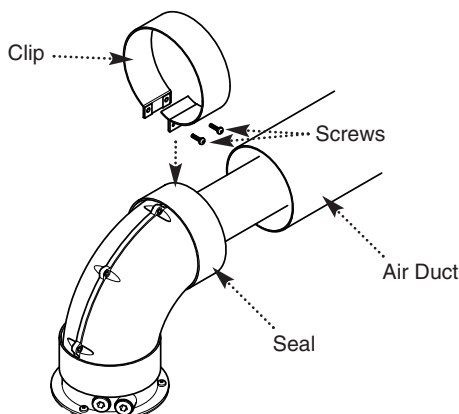

Fig. 25

8. Insert the flue duct into the air duct and pass them through the hole in the wall.

9. Take one of the rubber seals and position it on the boiler flue adaptor. Engage the flue elbow on the adaptor and pull the sleeve up so that it equally covers the joint (Fig. 22).

10. Remove the screws from one of the clips provided. Prise the clip apart and fit it over the seal (Fig. 23). Set the elbow to the required angle.

11. Refit the screws to the clip and tighten them to secure the elbow. Take the second rubber seal and position it on the flue elbow.

12. Locate the flue duct clamp on the flue outlet elbow. Draw the flue duct out of the air duct, engage it in the clamp and tighten the screws (Fig. 24).

13. Draw the air duct out of the wall and align it with the elbow. Position the seal so that it equally covers the joint (Fig. 25).

14. Remove the screws from the second clip provided. Prise the clip apart and fit it over the seal. Refit the screws to the clip and tighten them (Fig. 25).

15. Where possible position the clips so that the screws are not visible.

16. Make good between the wall and air duct outside the building.

17. Fit the circular flue trim outside if required, and if necessary fit a terminal guard (see Section 7.10 & 7.11).

VERTICAL FLUE

1. Only a flue approved with the Potterton Performa 28 can be used.

8.0 Installation

8.7 Making The Electrical Connections

To connect the mains input cable proceed as follows:-

1. Slacken the fascia panel securing screws and lift the outercase panel so that its securing tabs are clear of the fascia. Remove the panel.
2. Undo the screws securing the fascia panel and hinge it down (Fig. 26).
3. Remove the control box cover securing screws. Disengage the barbs on the control box from the cover. Remove the cover (Fig. 27).
4. Slacken the cable clamp on the LH side of the boiler chassis (Fig. 28). Insert the cable through the clamp and route it to the terminal block.
5. Slacken the screws in the terminal block, connect the input cable, and tighten the screws.
6. If an external control is to be connected it can be done at this point. Run the input cable from the external control through the second cable clamp on the boiler chassis. Refer to the instructions supplied with the control.

7. To connect external control(s) remove the link between terminals 1 & 2. The 230V supply at terminal 1 can be connected to the external control. The switched output from the external control must be connected to terminal 2. (Fig. 29).

NOTE: If the room thermostat being used incorporates an anticipator it **MUST** be wired as shown in Fig. 29

IMPORTANT: The external control **MUST** be suitable for 230V switching.

8. Ensure that both mains input and, where fitted, external control input cables have sufficient slack to allow the control box to drop down. Tighten the cable clamp(s) on the boiler chassis.

9. If the optional integral timer is to be used it should be fitted at this point. Refer to the instructions supplied with the timer.

8.8 Preliminary Electrical Checks

1. Prior to commissioning the boiler preliminary electrical system checks should be carried out.
2. These should be performed using a suitable meter, and include checks for Ground Continuity, Resistance to Ground, Short Circuit and Polarity.

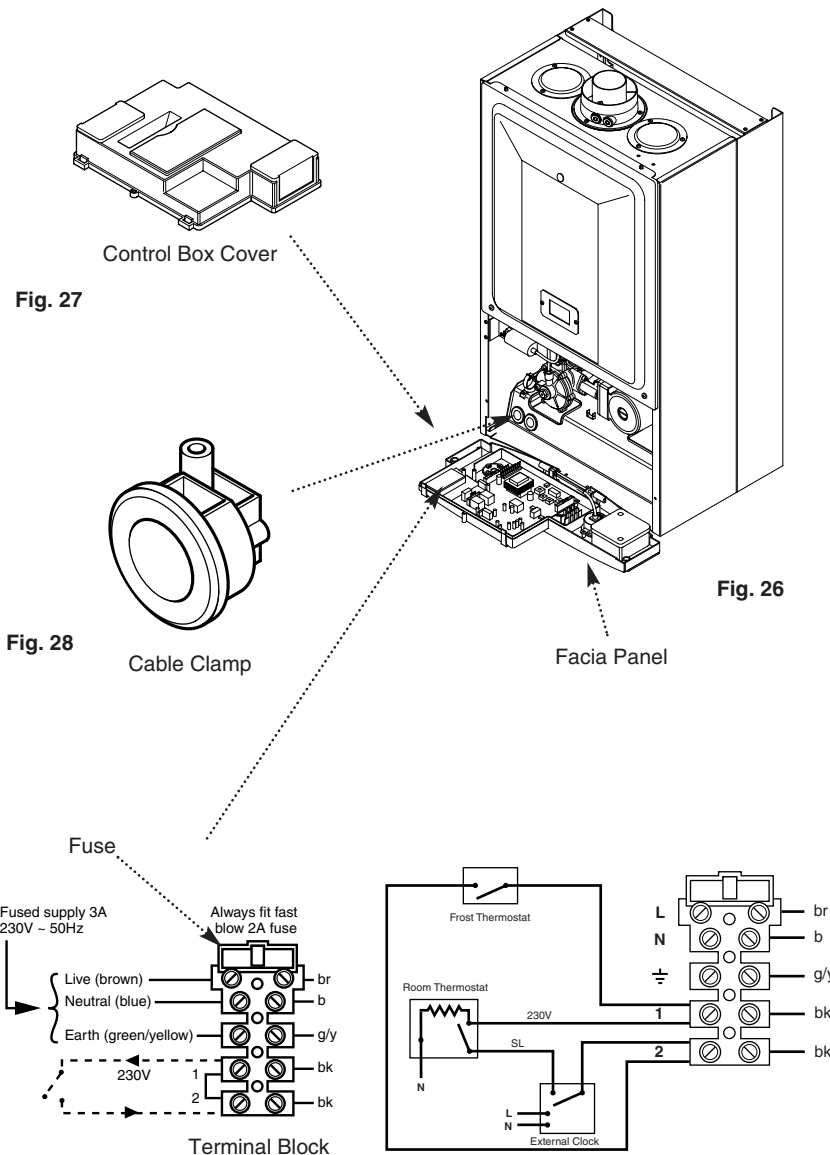
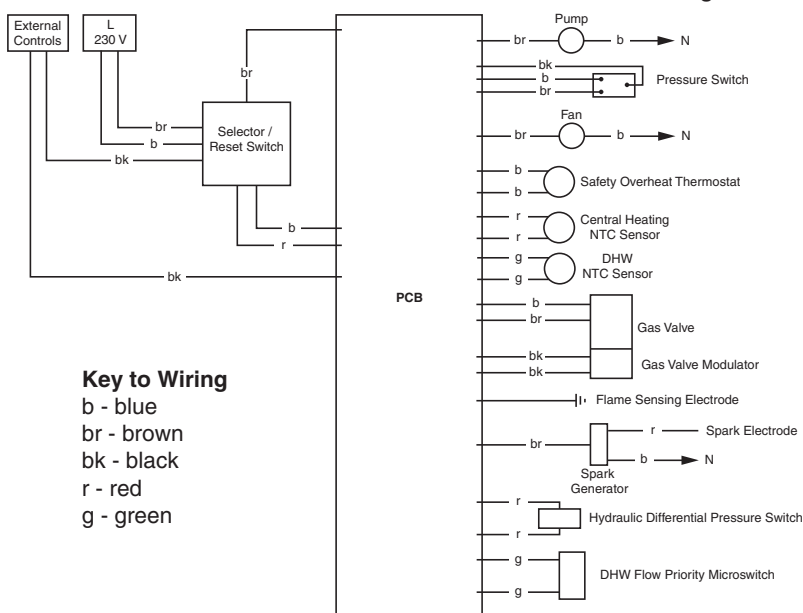

Fig. 29

Functional Flow Diagram

Fig. 30



9.0 Commissioning the Boiler

9.1 Commissioning the Boiler

1. Reference should be made to BS 5449 Section 5 when commissioning the boiler.
2. Open the mains water supply to the boiler.
3. Open all hot water taps to purge the DHW system.
4. Ensure that the filling loop is connected and open, then open the heating flow and return valves on the boiler.
5. Open the screw on the automatic air vent (Fig. 31).
6. The system must be flushed in accordance with BS 7593 (see Section 6.2) and the flushing agent manufacturers instructions.
7. Pressurise the system to 1.0 bar then close and disconnect the filling loop.
8. Turn the gas supply on and purge the system according to BS 6891.
9. Test for gas soundness.
10. If at any time during commissioning it is required to terminate a particular cycle, e.g. the pump overrun period, turn the selector to the OFF position and then back to either (OFF) or (ON) (Fig. 32).

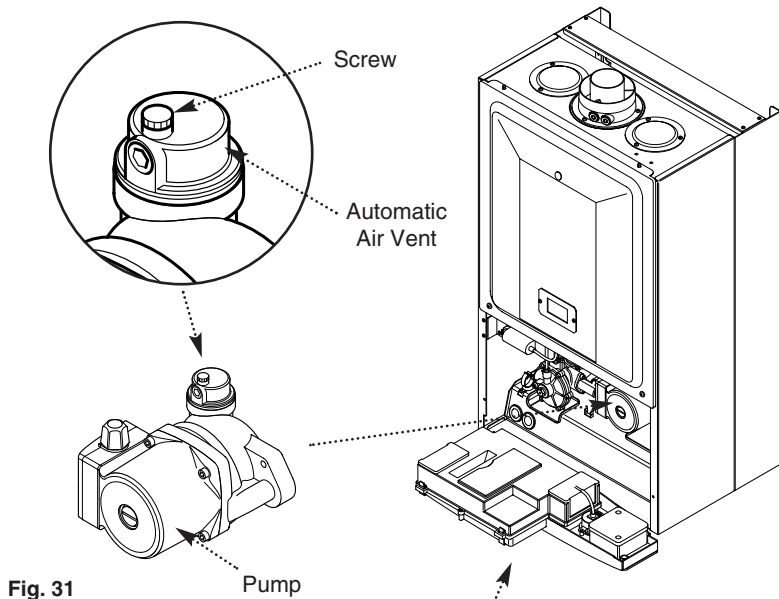

Fig. 31

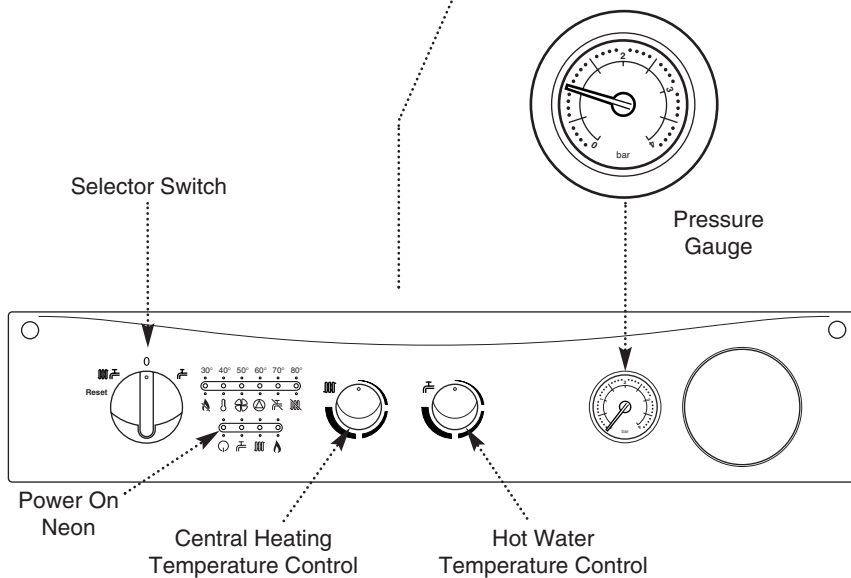



Fig. 32

9.0 Commissioning the Boiler

9.2 Checking the Burner Pressure

1. Turn on the gas and electrical supplies to the boiler and ensure that all external controls are calling for heat.
 2. Set the temperature controls to maximum and the selector switch to the Off position (Fig. 36).
 3. Slacken the pressure test point sealing screw on the gas valve and connect a pressure gauge (Fig. 33).
 4. Undo the screws securing the inner door panel. Lift the panel slightly to disengage it from the studs on top of the case.
 5. Turn the selector switch fully anticlockwise against the spring pressure to the reset position and hold for 2 seconds to reset the boiler.
 6. Turn the selector switch to the Central Heating and Domestic Hot Water position (). The power On neon () will illuminate (Fig. 36).
 7. Turn a hot water tap on to give a flow rate of at least 10l/min.
 8. The pressure should be as quoted in Section 4.0 Technical Data. If not, check that the gas supply pressure is correct (Natural Gas 20mbar, Butane 30mbar and Propane 37mbar).
 9. The pressure can be adjusted if required.
 10. To check minimum pressure first remove one of the modulator wires.
- Adjusting the Pressure** (Fig. 34)
11. Prise apart the spring clip retaining the modulator. Draw the modulator off the valve.
 12. Slacken the adjuster tube locknut. Rotate the tube until the correct maximum pressure is achieved. Tighten the locknut.
 13. Rotate the minimum rate adjuster screw until the correct minimum pressure is achieved.
 14. Once the pressure has been set turn the boiler off and disconnect the pressure gauge.
 15. Tighten the pressure test screw and refit the modulator to the valve. Reassemble in reverse order.

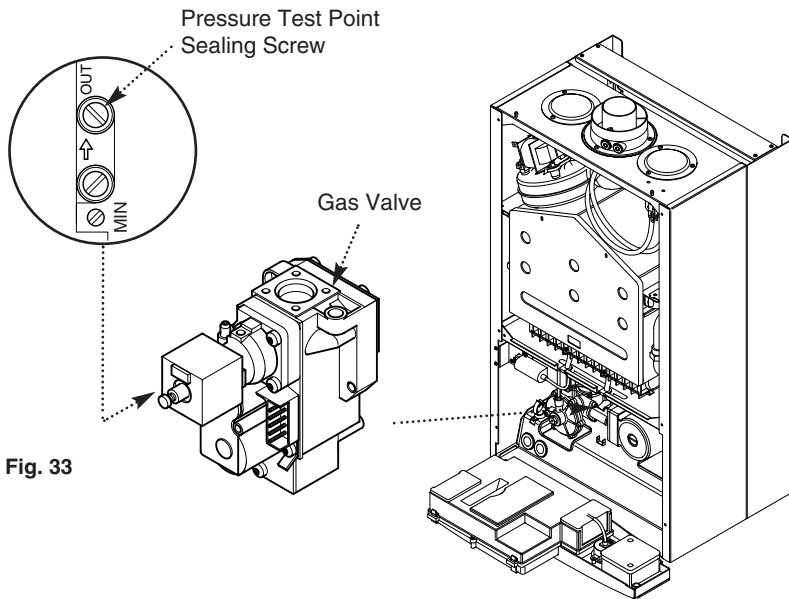

Fig. 33

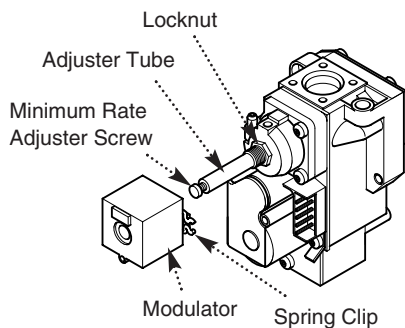

Fig. 34

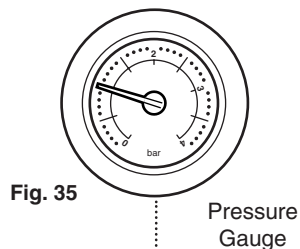

Fig. 35

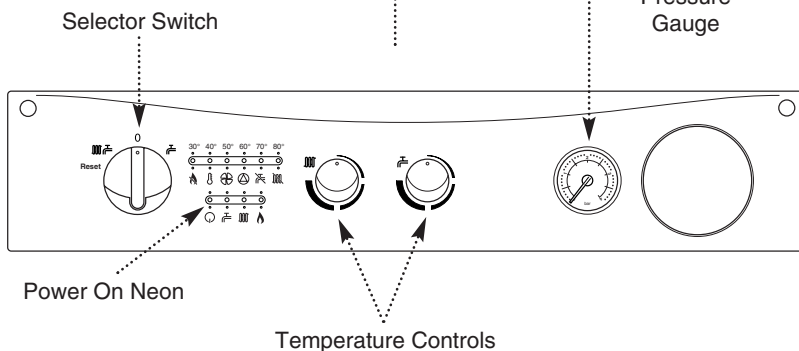

Fig. 36

10.0 Completion

10.1 Completion

1. Hinge the facia panel upwards and refit the case front panel. Secure them with the screws previously removed (Fig. 37).
2. Instruct the user in the operation of the boiler and system, explaining the operational sequence.
3. Carefully read and complete all sections of the "Benchmark" Installation, Commissioning and Service Record Log Book that are relevant to the appliance and installation. The details of the Log Book will be required in the event of any warranty work. The Log Book must be handed to the user for safe keeping and each subsequent regular service visit recorded.
4. Hand over the Users Operating, Installation and Servicing Instructions and the Log Book, giving advice on the necessity of regular servicing.

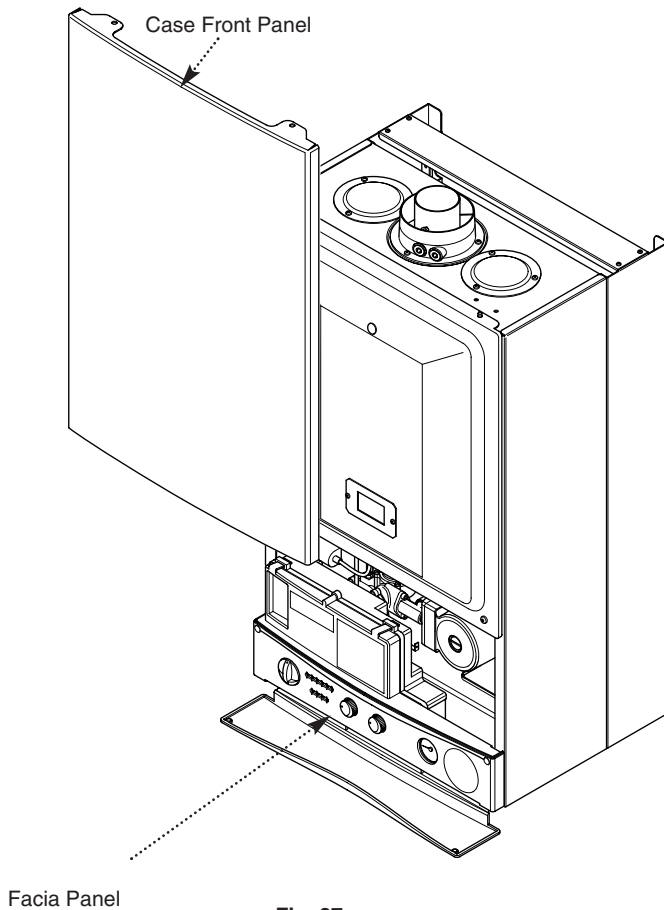
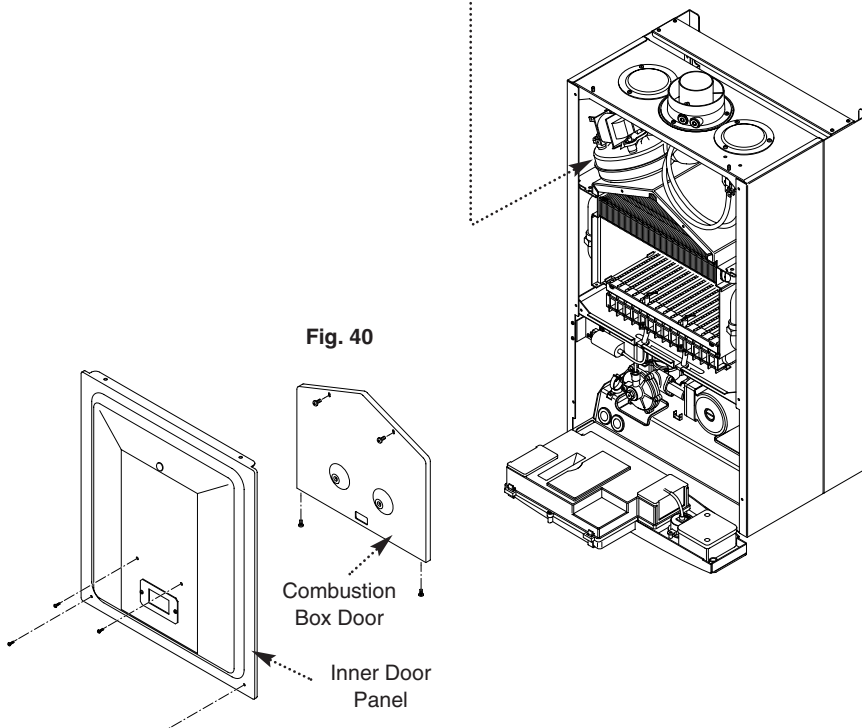
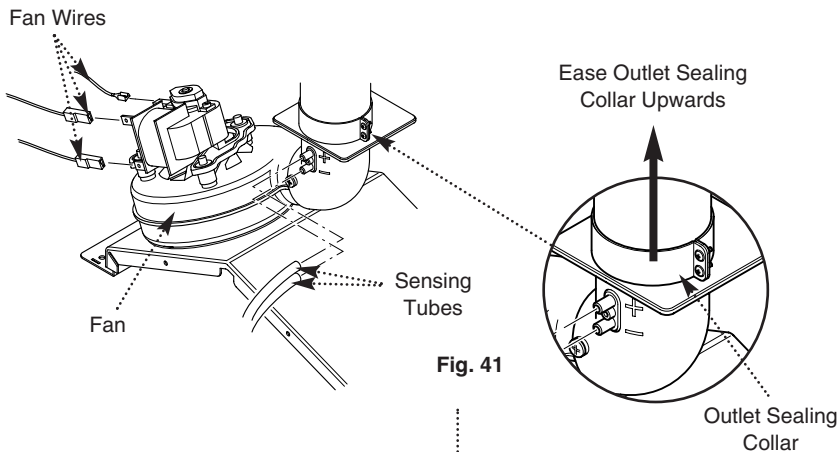
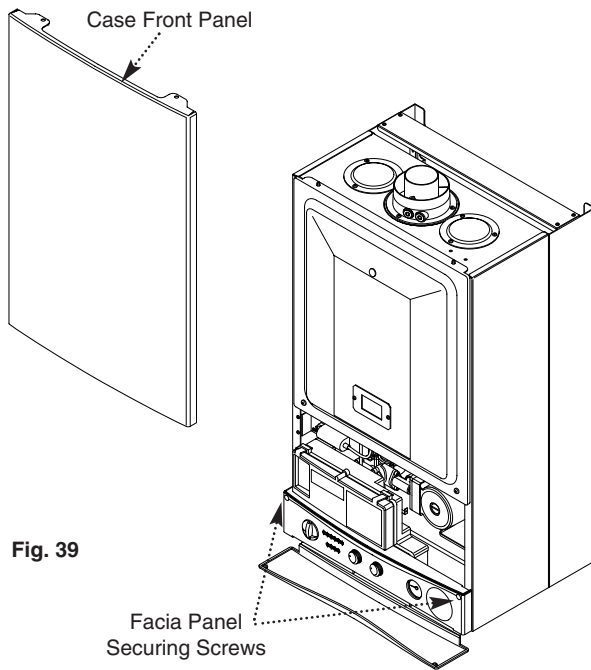

Fig. 37

11.0 Servicing the Boiler

11.1 Annual Servicing

1. For reasons of safety and economy, it is recommended that the boiler is serviced annually. Servicing must be performed by a competent person.
2. After servicing, complete the relevant section of the "Benchmark" Installation, Commissioning and Service Record Log Book. This should be in the possession of the user.
3. Ensure that the boiler is cool.
4. **Ensure that both the gas and electrical supplies to the boiler are isolated.**
5. Slacken the screws securing the fascia panel. Lift the outercase panel so that its securing tabs are clear of the fascia. Remove the panel, allowing the fascia to hinge down (Fig. 39).
6. Remove the screws securing the inner door panel. Lift the panel slightly to disengage it from the studs on top of the case (Fig. 40).
7. Note the positions of the two sensing tubes on the outlet elbow and three wires on the fan motor and remove them (Fig. 41).
8. Slacken the screws on the outlet sealing collar. Ease the collar upwards as far as possible (Fig. 41).
9. Remove the four screws securing the combustion box door and remove the door (Fig. 40).



11.0 Servicing the Boiler

11.1 Annual Servicing (Cont)

10. Remove the spring clips retaining the air box side baffle plates. Disengage the tabs on the baffles from the slots in the fan hood (Fig. 42).

11. Undo the screws securing the fan and hood to the appliance back panel. Draw the assembly forwards (Fig. 42a).

12. Undo the screws securing the burner to the injector manifold. Draw the burner out of the combustion box, pulling the electrode grommets from the slots in the combustion box lower panel (Fig. 43).

13. Disconnect the electrode leads and grommets from the electrodes. Completely remove the burner (Fig. 43).

14. Brush any deposits from the injectors. Do not use a pin or wire to clean them.

15. Brush the burner blades and venturis and clean the combustion box.

16. Ensure that the heat exchanger fins are clear of any obstruction.

DHW Filters (Fig. 44)

17. If the flow of domestic hot water is diminished, it may be necessary to clean the filters.

18. Initially check the cold water inlet tap filter.

19. Turn the tap off. Undo the blanking cap and remove the threaded bush (Fig. 43a).

20. Extract the filter and rinse thoroughly in clean water. Reassemble and check the flow. If required clean the manifold filter as described below.

21. Undo the filter cartridge from the inlet/return manifold.

22. Dismantle the cartridge and carefully remove the flow regulator and filter gauze. Rinse them thoroughly in clean water and reassemble in reverse order.

23. Check that the pressure vessel charge is 0.5bar, reassemble in reverse order of dismantling and recommission.

24. Turn the selector switch fully anticlockwise against the spring pressure to the reset position and hold for 2 seconds to reset the boiler.

25. Complete the relevant section of the "Benchmark" Installation, Commissioning and Service Record Log Book and hand it back to the user.

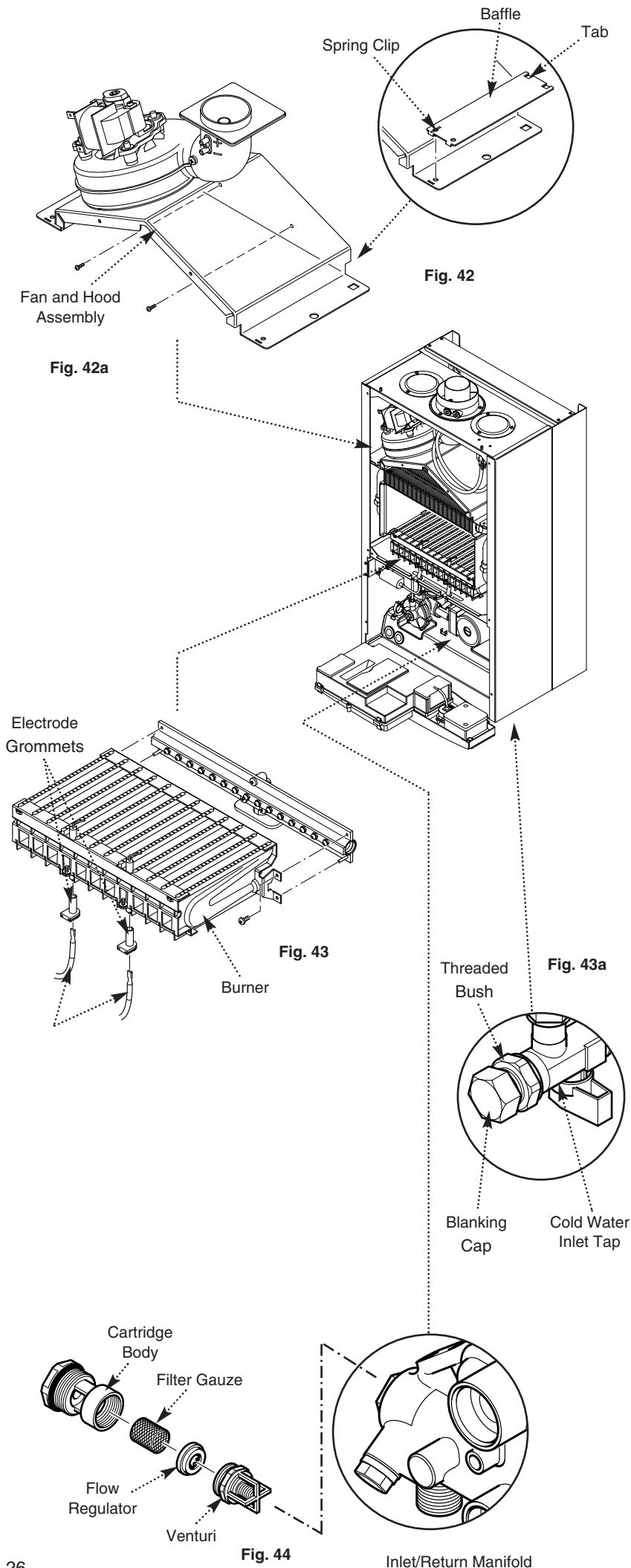

12.0 Changing Components

IMPORTANT: When changing components ensure that both the gas and electrical supplies to the boiler are isolated before any work is started. When the component has been changed turn the selector switch fully anticlockwise against the spring pressure to the reset position and hold for 2 seconds to reset the boiler before recommissioning.

See Section 11.1 "Annual Servicing" for removal of case panel, door etc.

12.1 Pressure Switch (Fig. 45)

1. Note the positions of the two sensing tubes and three wires and remove them.
2. Remove the two screws holding the pressure switch to the combustion box top panel.
3. Fit the new pressure switch and reassemble all components in reverse order of dismantling.

12.2 Fan (Figs. 46 & 47)

1. Note the positions of the two sensing tubes on the outlet elbow and three wires on the fan motor and remove them.
2. Slacken the screws on the outlet sealing collar. Ease the collar upwards as far as possible.
3. Remove the four screws securing the combustion box door and remove the door.
4. Remove the spring clips retaining the air box side baffle plates. Disengage the tabs on the baffles from the slots in the fan hood.
5. Undo the screws securing the fan hood to the appliance back panel, and draw the fan and hood assembly forwards.
6. Remove the screws and spring washers securing the fan to the hood.
7. Fit the new fan to the hood using the screws and spring washers previously removed.
8. Reassemble in reverse order of dismantling.

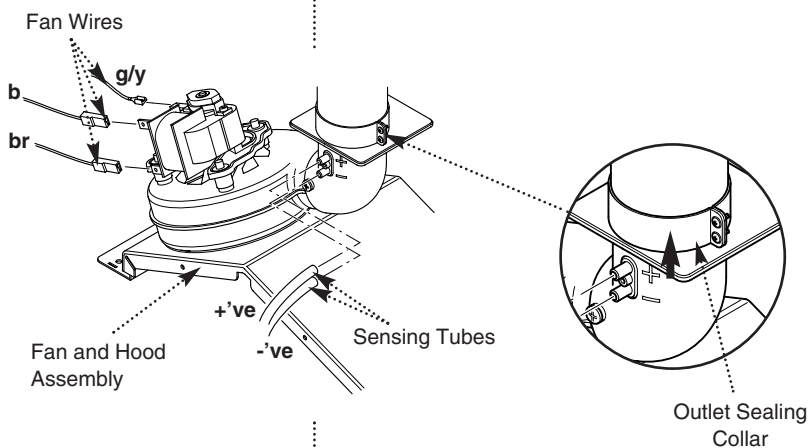
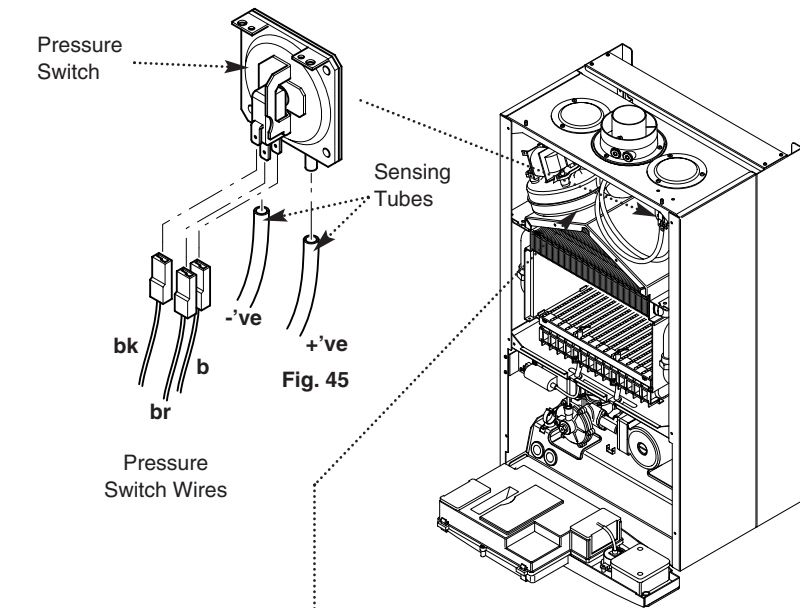

Fig. 46

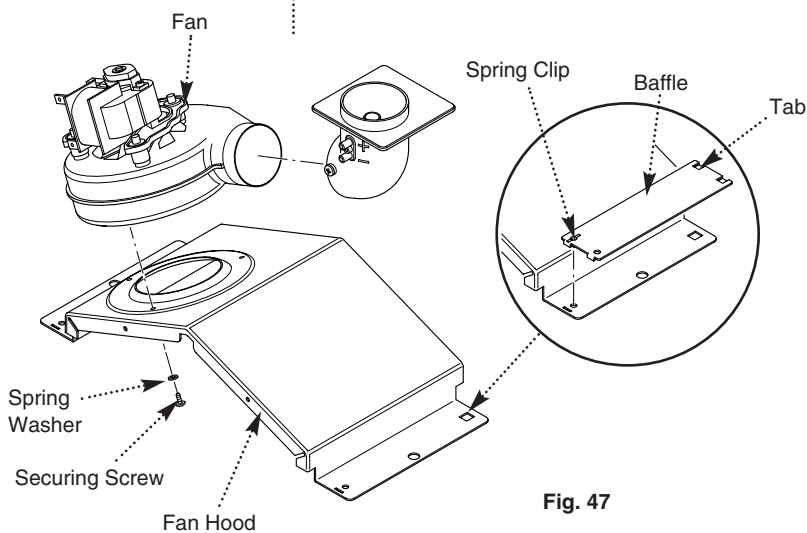

Fig. 47

12.0 Changing Components

12.3 Heat Exchanger (Fig. 48)

1. Note the positions of the two sensing tubes on the outlet elbow and three wires on the fan motor and remove them.

2. Slacken the screws on the outlet sealing collar. Ease the collar upwards as far as possible.

3. Remove the four screws securing the combustion box door and remove the door.

4. Remove the spring clips retaining the air box side baffle plates. Disengage the tabs on the baffles from the slots in the fan hood.

5. Undo the screws securing the fan hood to the appliance back panel, and draw the fan and hood assembly forwards.

6. Drain the primary circuit. Prise the two pipe connecting clips off the joints in the flow and return pipes.

7. Lift the heat exchanger to disconnect the flow and return pipe joints. Withdraw it from the appliance, taking care not to damage the rear insulation piece.

8. Fit the new heat exchanger.

9. Reassemble in reverse order of dismantling, and repressurise the system.

12.4 Burner (Fig. 49)

1. Remove the four screws securing the combustion box door and remove the door.

2. Undo the screws securing the burner to the injector manifold. Draw the burner out of the combustion box, pulling the electrode grommets from the slots in the combustion box lower panel.

3. Disconnect the electrode leads and grommets from the electrodes. Completely remove the burner.

4. Undo the screws securing the electrodes to the burner. Examine the condition of the electrodes, replacing if necessary. Fit the electrodes to the new burner.

5. Engage the burner location brackets over the studs on the injector manifold and reassemble in reverse order.

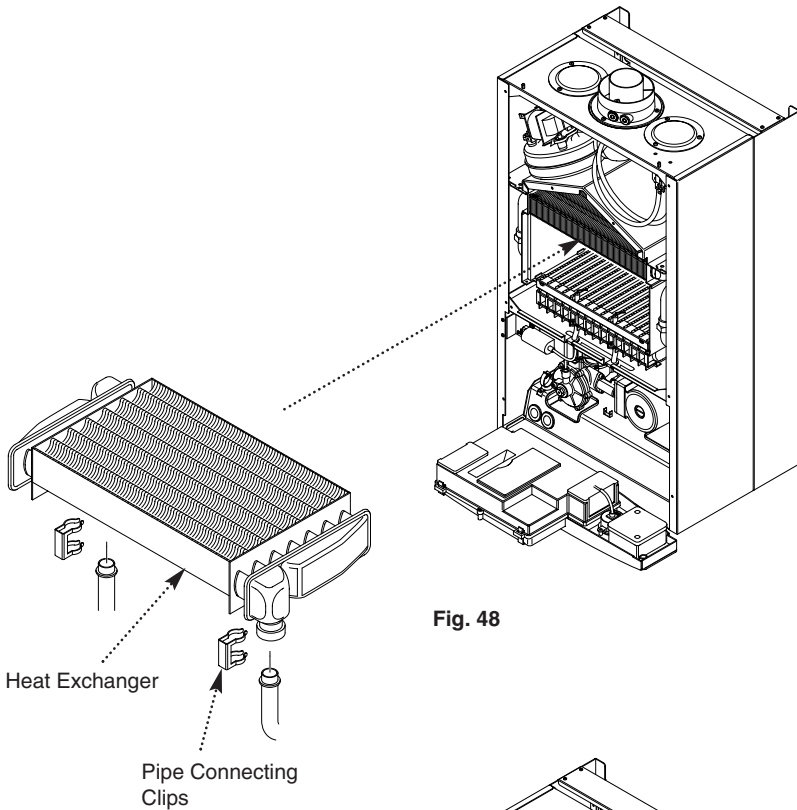

Fig. 48

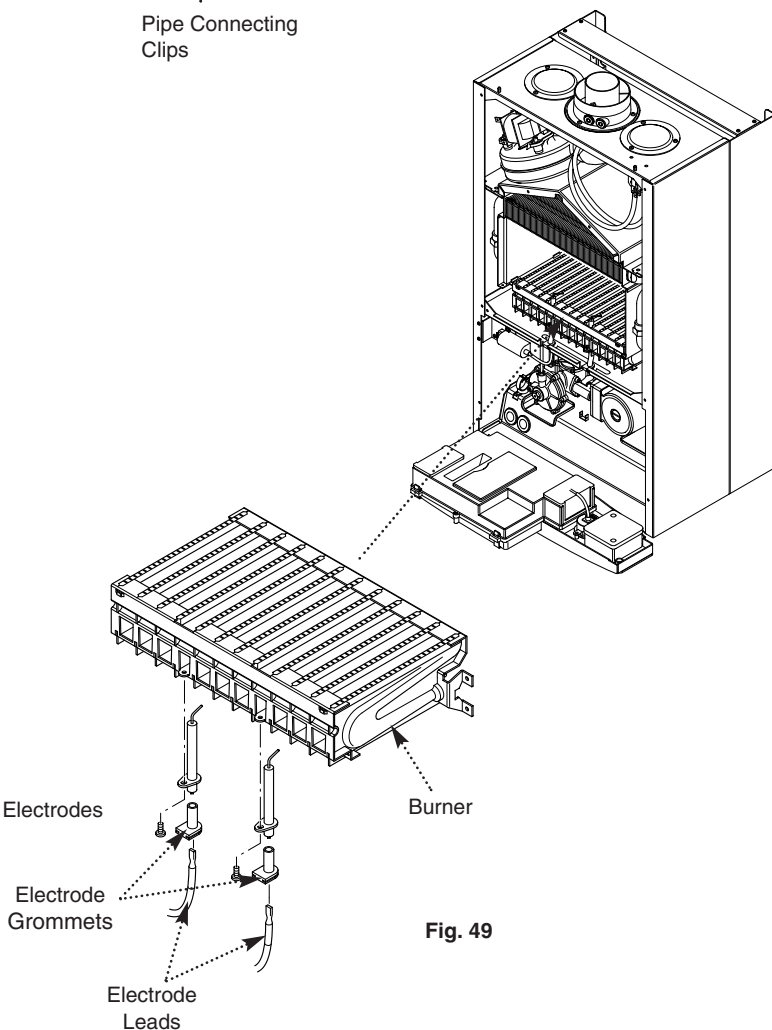

Fig. 49

12.0 Changing Components

12.5 Injectors (Fig. 50)

1. Remove the burner as described in Section 12.4.
2. Undo the screws securing the injector manifold to the inlet elbow and remove the manifold.
3. Unscrew and replace injectors as required and examine the sealing gasket, replacing as necessary. Reassemble in reverse order.

12.6 Electrodes (Fig. 50)

1. Remove the four screws securing the combustion box door and remove the door.
2. Undo the screws securing the burner to the injector manifold. Draw the burner out of the combustion box, pulling the electrode grommets from the slots in the combustion box lower panel.
3. Disconnect the lead and grommet from the electrode being replaced. Undo the securing screw and withdraw the electrode to the burner.
4. Reassemble in reverse order.

12.7 Insulation (Fig. 51)

1. Remove the four screws securing the combustion box door and remove the door.
2. Slide the side insulation pieces carefully out of their carriers.
3. To replace the rear insulation piece it is necessary to remove the heat exchanger as described in Section 12.3 and slide out the side pieces.
4. The combustion box door insulation piece can be replaced by carefully bending up the two retaining tabs.
5. Replace all insulation pieces and reassemble in reverse order.

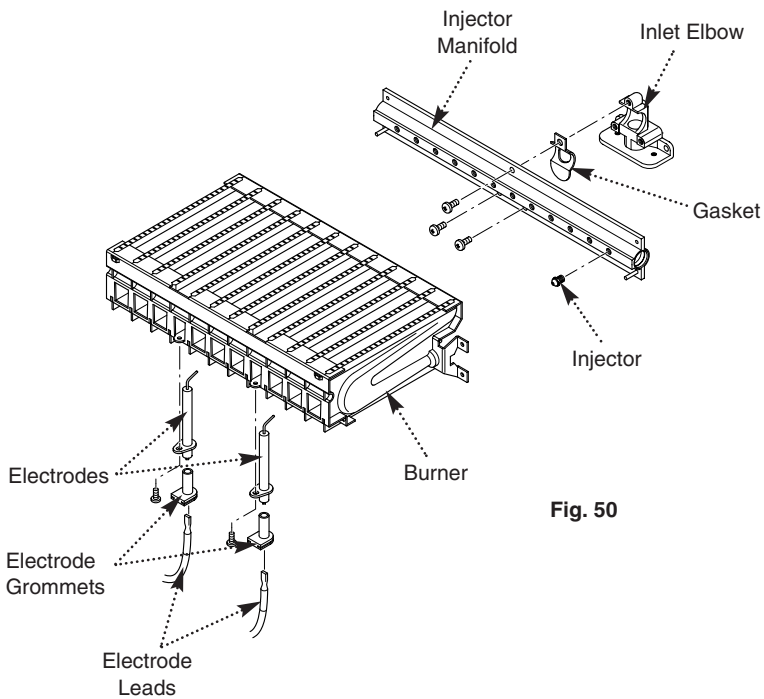

Fig. 50

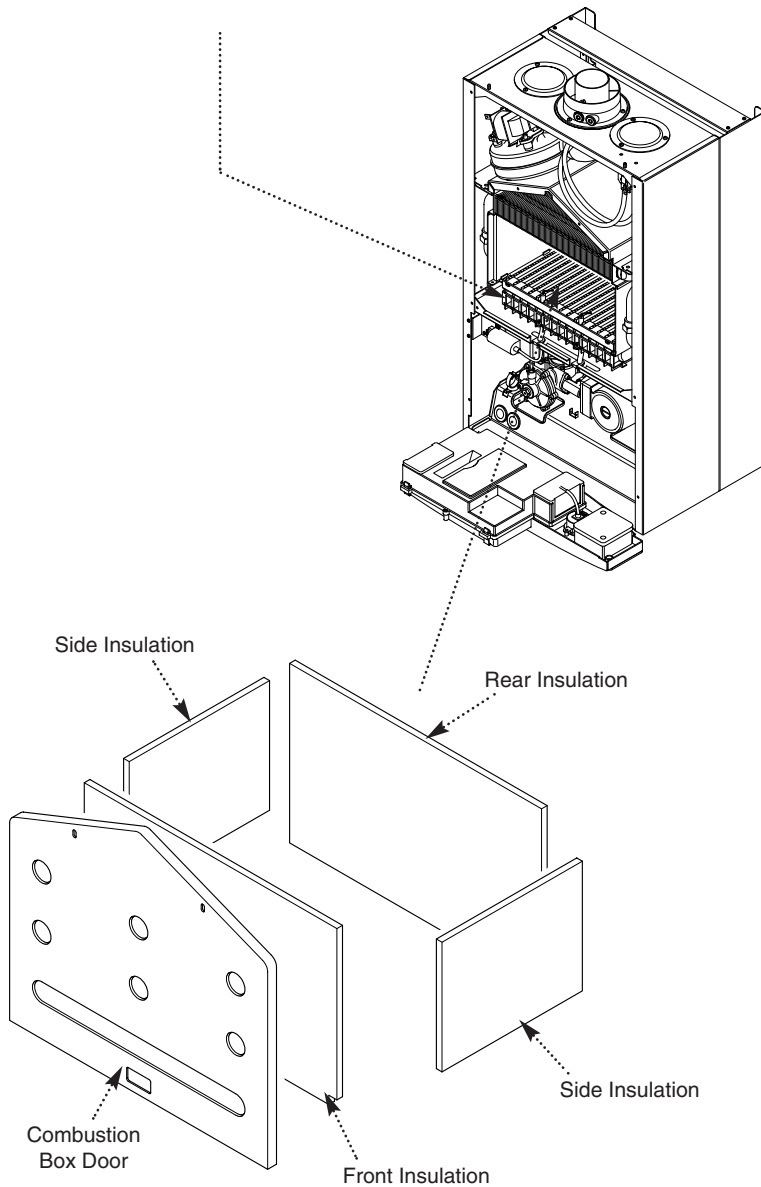

Fig. 51

12.0 Changing Components

12.8 Gas Valve (Fig. 52)

1. Undo the nut on the gas feed pipe under the boiler.
2. Remove the securing screws and hinge the fascia panel down.
3. Disconnect the earth wire and pressure sensing pipe from the valve. Undo the screw securing the electrical plug to the valve and disconnect the plug. Disconnect the wires from the valve modulator.
4. Remove the screws securing the inlet pipe flange to the boiler bottom panel and those securing the outlet manifold to the burner manifold.
5. Remove the valve from the boiler.
6. Note the orientation of the inlet pipe and outlet manifold. Undo the securing screws and remove the pipe and manifold.
7. Examine the 'O' ring seals for damage, replacing as necessary.
8. Fit the inlet pipe and outlet manifold to the new valve, ensuring that the 'O' ring seals are in place.
9. Reassemble in reverse order and check the burner pressure (Section 9.2).

12.9 Central Heating Temperature Sensor (Fig. 53)

1. Ease the retaining tab on the sensor away and disconnect the electrical plug.
2. Unscrew the sensor from its pocket and reassemble in reverse order. The plug will only fit one way.

12.10 Safety Thermostat (Fig. 53)

1. Pull the electrical connections off the thermostat.
2. Remove the screws securing the thermostat to the mounting plate on the flow pipe.
3. Reassemble in reverse order. The thermostat is not polarised - either wire can fit either terminal on the thermostat.

12.11 DHW Temperature Sensor (Fig. 53a)

1. Turn off the mains water supply and draw off the residual domestic hot water.
2. Ease the retaining tab on the sensor away and disconnect the electrical plug.
3. Unscrew the sensor from the plate heat exchanger manifold. Examine the sealing washer, replacing if necessary.
4. Reassemble in reverse order. The plug will only fit one way.

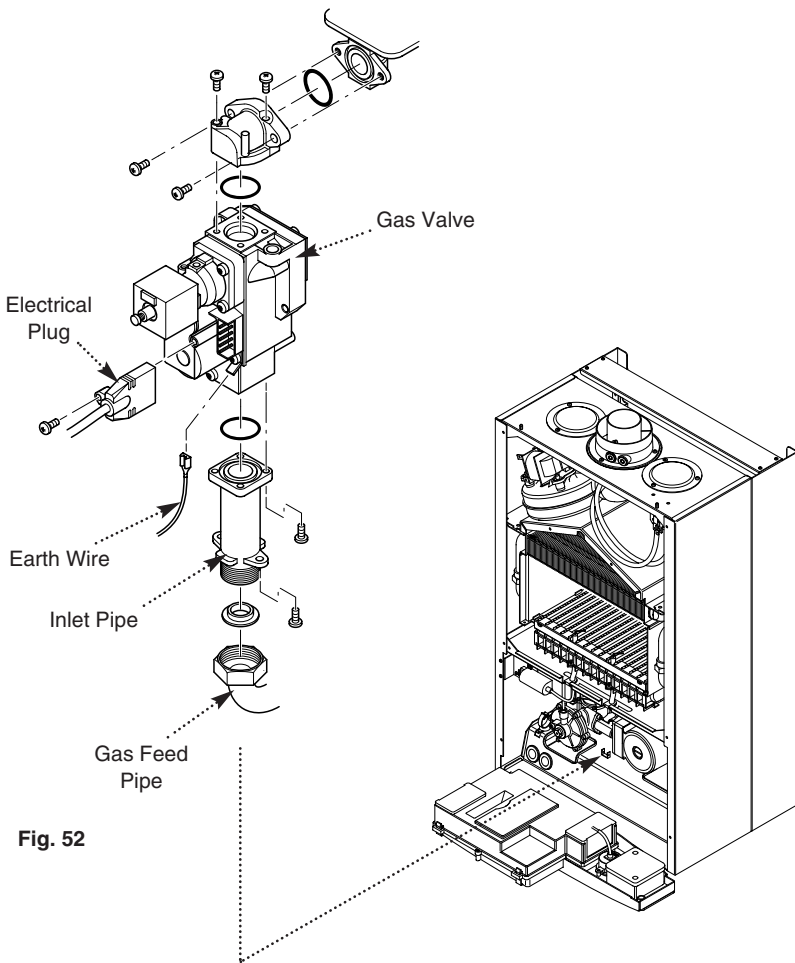

Fig. 52

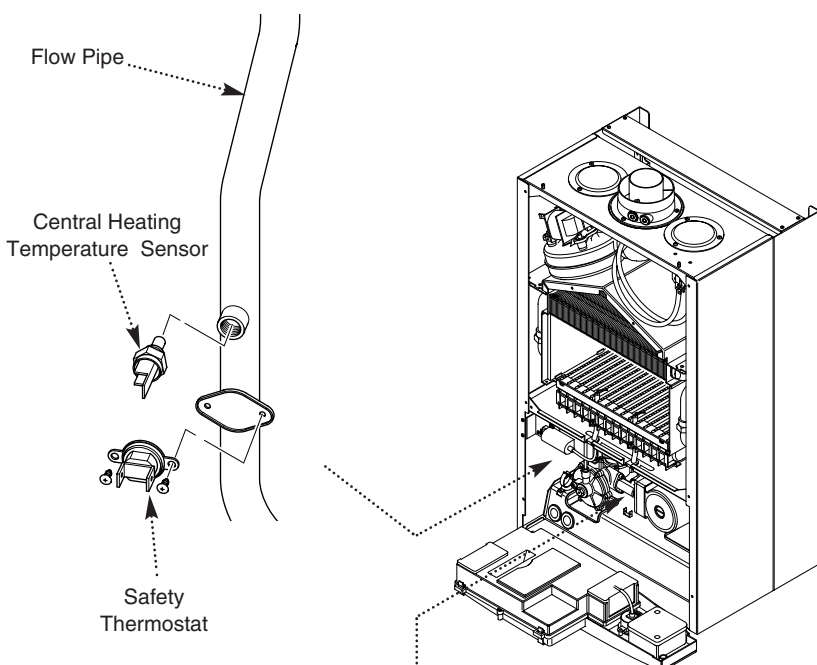

Fig. 53

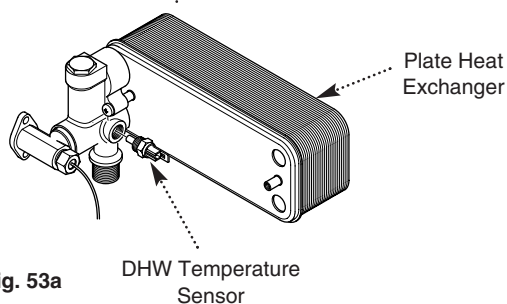

Fig. 53a

12.0 Changing Components

12.12 Pump - Head Only (Fig. 54)

1. Drain the primary circuit and remove the socket head screws securing the pump head to the body and draw the head away.
2. Undo the screw on the pump wiring cover and remove the cover. Using a suitable flat bladed screw driver press the cable securing levers downwards to release each wire after noting their position.
3. A standard replacement Grundfos 15-60 head can now be fitted. Connect the pump wiring to the new head. **The pump speed must be set to 3** (Fig. 55).
4. Reassemble in reverse order.

12.13 Pump - Complete (Fig. 56)

1. Drain the primary circuit and unscrew the automatic air vent from the pump body. Undo the two screws securing the body to the pipe and manifold and draw the pump forwards.
2. Undo the screw on the pump wiring cover and remove the cover. Using a suitable flat bladed screw driver press the cable securing levers downwards to release each wire after noting their position.
3. Connect the wiring to the new pump. Examine the 'O' ring seals on the return pipe and manifold, replacing if necessary.
4. Fit the air vent to the pump body and reassemble in reverse order.

12.14 Automatic Air Vent (Fig. 56)

1. Drain the primary circuit and unscrew the automatic air vent from the pump body.
2. Examine the 'O' ring seal, replacing if necessary, and fit it to the new automatic air vent.
3. Reassemble in reverse order.

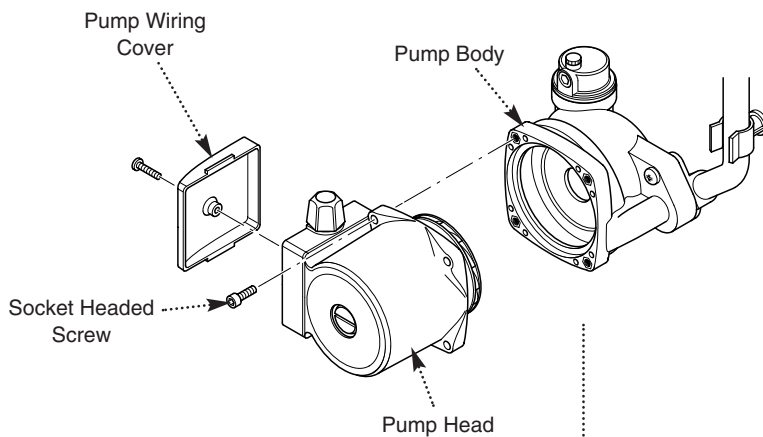
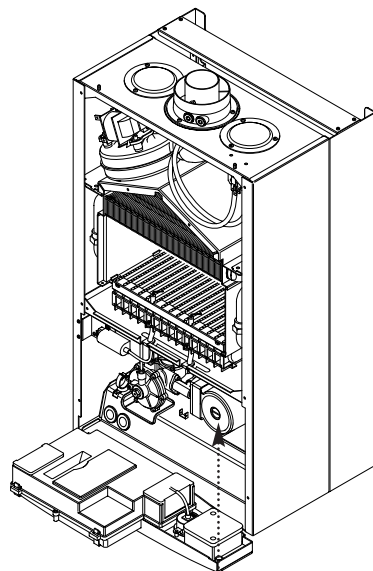
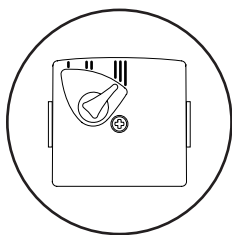

Fig. 54



Pump Setting

Fig. 55

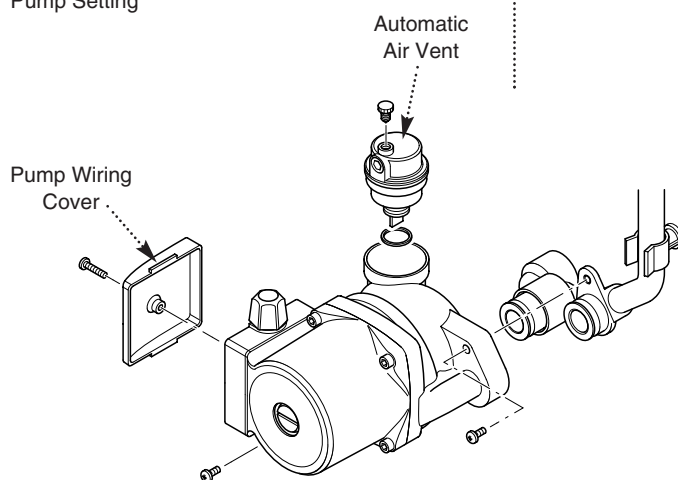

Fig. 56

12.0 Changing Components

12.15 Pressure Gauge (Figs. 57 & 58)

1. Drain the primary circuit and undo the nut on the pressure gauge capillary.
2. Remove the timer cover and ease the timer wiring aside. Undo the screws securing the gauge retaining bracket.
3. Remove the bracket and gauge assembly. Depress the barbs on the side of the gauge and remove the retaining bracket.
4. Reassemble in reverse order.

12.16 Expansion Vessel (Fig. 59)

1. To replace the expansion vessel it is necessary to remove the boiler from the wall.

Note: Alternatively a vessel of equivalent capacity can be fitted on the system return pipe as close as possible to the boiler.

2. Drain the system and undo all gas and water connections. Remove the flue elbow.
3. Lift the boiler off the wall plate and lay it on it's side on a clean flat surface.
4. Undo the nut on the vessel outlet spigot, and remove the locknut and spring washer securing the spigot to the boiler chassis.
5. Undo the screws and remove the appliance upper cross member. Slide the expansion vessel out of the retaining clips.
6. Reassemble in reverse order. Fully recommission the appliance and system.

12.17 Spark Generator (Fig. 60)

1. Pull the electrode lead off the spark generator. Remove the screws and spring washers securing the generator to it's mounting bracket.
2. Pull the rubber shroud off the generator input plug and disconnect the plug.
3. Reassemble in reverse order.

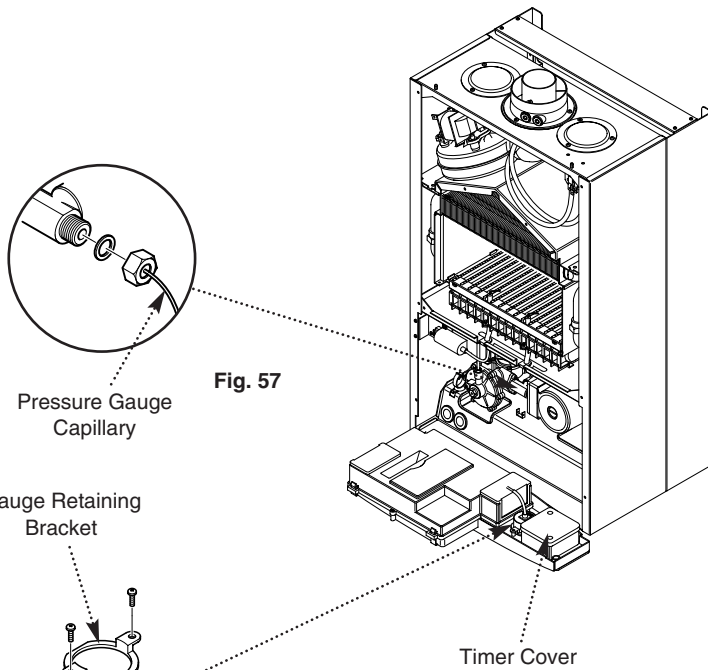

Fig. 57

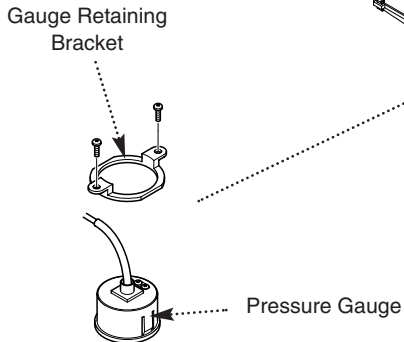

Fig. 58

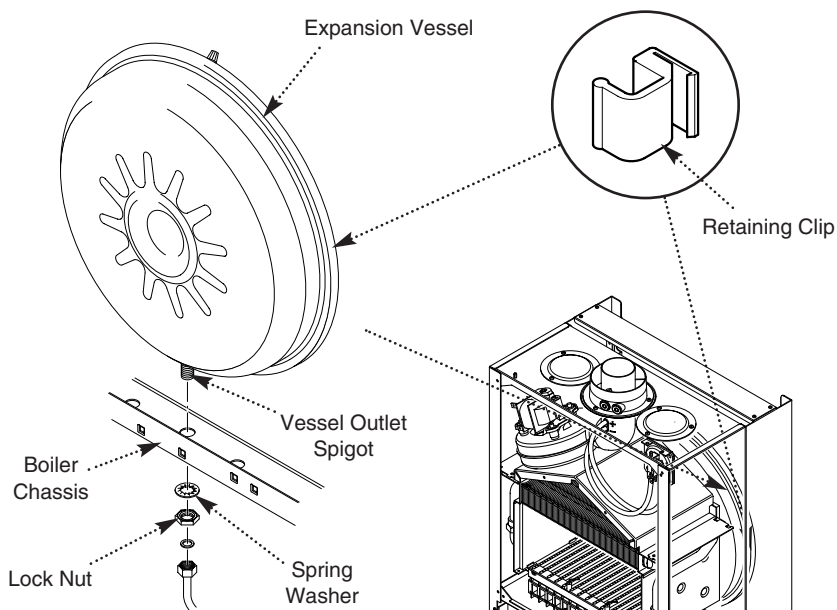

Fig. 59

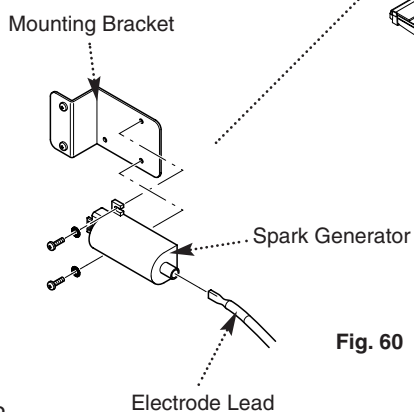

Fig. 60

12.0 Changing Components

12.18 Pressure Relief Valve (Fig. 61)

1. Drain the primary circuit.
2. Disconnect the discharge pipe from the valve. Using a suitable hexagon key undo the grub screw sufficiently to release the valve.
3. Note the orientation of the valve, rotate it and withdraw it from the manifold.
4. Fit the new valve and 'O' ring seal and set to the previously noted orientation. Reassemble in reverse order.

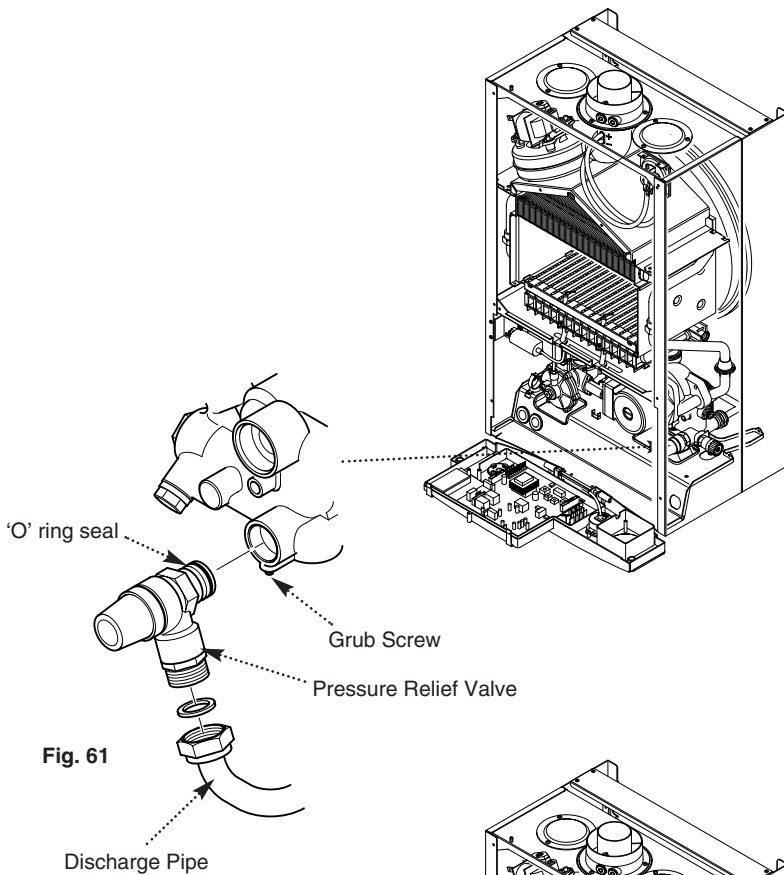

Fig. 61

12.19 P.C.B. (Fig. 62)

1. Note the settings of the temperature control knobs, rotate them fully anticlockwise and carefully pull them off the drive pins.
2. Remove the screws securing the control box cover and release the cover retaining barbs from their slots. Disengage the rear of the cover from the control box hinge pin (Fig. 62).
3. Note the position of all plugs and wires on the P.C.B. and disconnect them.
4. Undo the securing screws and remove the P.C.B. Transfer the control knob drive pins to the new P.C.B. and turn them fully anticlockwise.
5. Reassemble in reverse order, ensuring that the temperature controllers are reset to their previous positions.

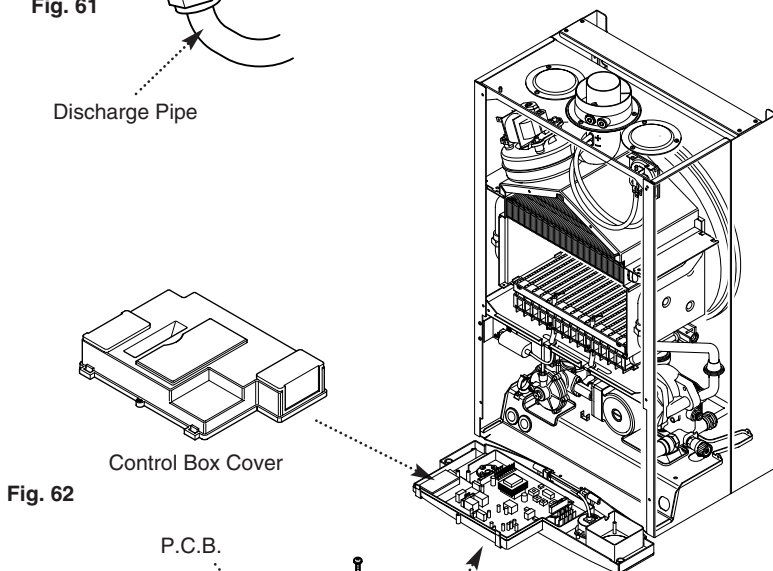

Fig. 62

12.20 Selector Switch

1. Note the setting of the selector switch knob and carefully pull it off the facia.
2. Remove the screws securing the control box cover and release the cover retaining barbs from their slots. Disengage the rear of the cover from the control box hinge pin.
3. Note the position of the electrical connections and the orientation of the switch. Remove the electrical connections.
4. Remove the screws securing the switch to the facia panel.
5. Fit the new switch, ensuring that it is correctly positioned and reassemble in reverse order.

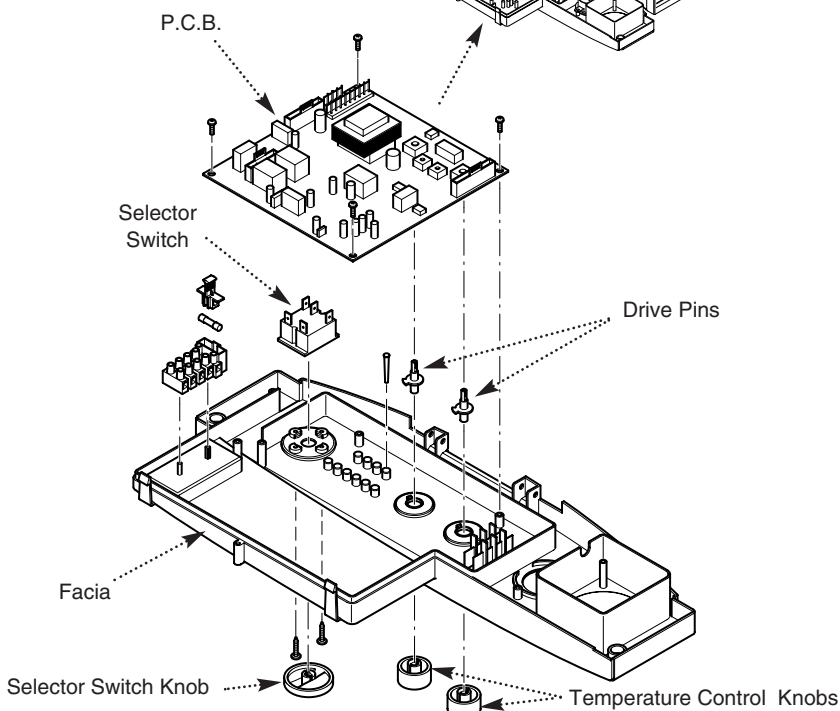

Fig. 63

12.0 Changing Components

12.21 Plate Heat Exchanger (Fig. 64)

1. Drain the primary circuit.
2. While supporting the heat exchanger undo the screws securing it to the brass manifolds.
3. Withdraw the heat exchanger upwards and to the left of the gas valve, taking care not to damage any wires or controls.

Seals

4. There are four rubber seals between the manifolds and heat exchanger which may need replacement.
5. Ease the seals out of the manifold. Replace carefully, ensuring that when the seal is inserted into the manifold it is parallel and pushed fully in.
6. When fitting the new heat exchanger note that the left hand location stud is offset towards the centre more than the right hand one.
7. Reassemble in reverse order.

12.22 Diverter Valve Assembly (Figs. 65 & 66)

The diverter valve assembly comprises of a central heating pressure differential valve and a domestic hot water pressure differential valve. These are connected to a manifold which is joined to the plate heat exchanger.

DHW Pressure Differential Valve (Fig. 66)

1. Drain the primary circuit.
2. Undo the screw securing the microswitch bracket to the valve (Fig. 65).
3. Disconnect the two sensing pipes and slacken the grub screws securing the valve to the diverter manifold.
4. Draw the valve away from the diverter manifold. The valve may now be replaced or split to examine the diaphragm.
5. To examine the diaphragm hold the valve body securely and carefully remove the six screws. The diaphragm spring will force apart the two halves of the valve.
6. Remove the plastic disc and pushrod assembly. Carefully examine the diaphragm and replace it if there is any damage.
7. Reassemble in reverse order.

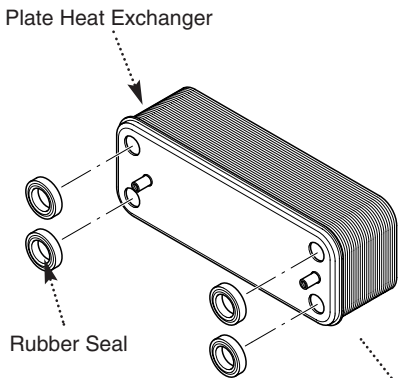

Fig. 64

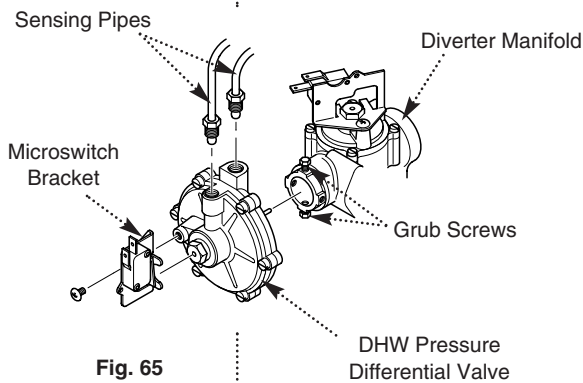
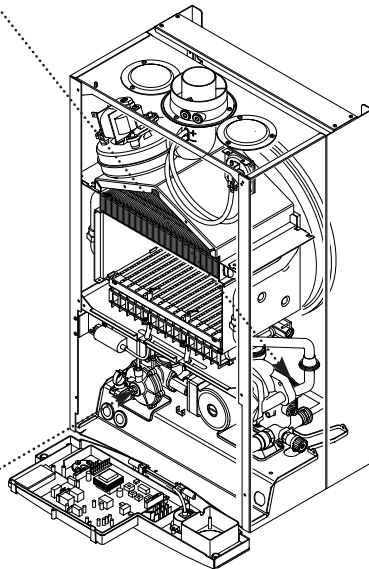

Fig. 65

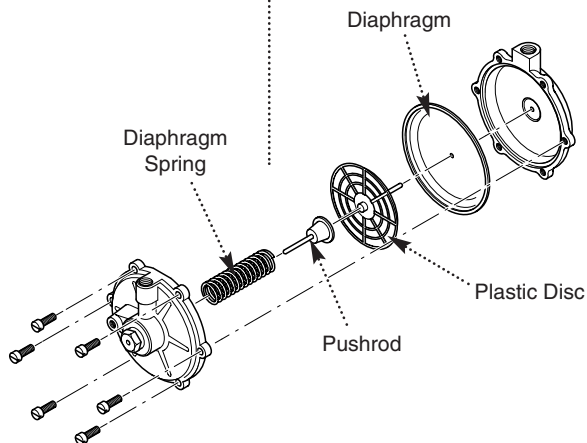

Fig. 66

12.0 Changing Components

12.22 Diverter Valve Assembly (Cont)

Pressure Differential Valve (Fig. 67)

1. Remove the pressure differential valve as described above.
2. From the brass diverter manifold undo the nut on the heating flow pipe. Remove the screw securing the diverter manifold to the appliance lower bracket.
3. Disconnect the pressure gauge capillary from the diverter manifold and remove the two wires from the microswitch.
4. Prise off the spring clip securing the by-pass pipe to the diverter manifold and disconnect the sensing pipe.
5. Ease the diverter manifold out of the plate heat exchanger manifold. Remove the assembly from the appliance.
6. Undo the screw securing the microswitch bracket to the valve body. The sensor may now be dismantled to examine the diaphragm.
7. To examine the diaphragm hold the assembly securely and carefully remove the four screws. The diaphragm spring will force the two halves of the valve apart.
8. Carefully examine the diaphragm and replace it if there is any damage.
9. Reassemble in reverse order.

CH Pressure Microswitch (Fig. 67)

1. Remove the two wires from the Pressure microswitch.
2. Undo the screw securing the microswitch bracket to the valve body.
3. Reassemble in reverse order.

12.23 Flow Regulator (Figs. 68 & 69)

1. Undo the filter cartridge from the inlet/return manifold.
2. Unscrew the venturi and remove the flow regulator.
3. Check the cleanliness of the filter gauze, rinsing thoroughly in clean water as necessary. Fit the new flow regulator and reassemble in reverse order.

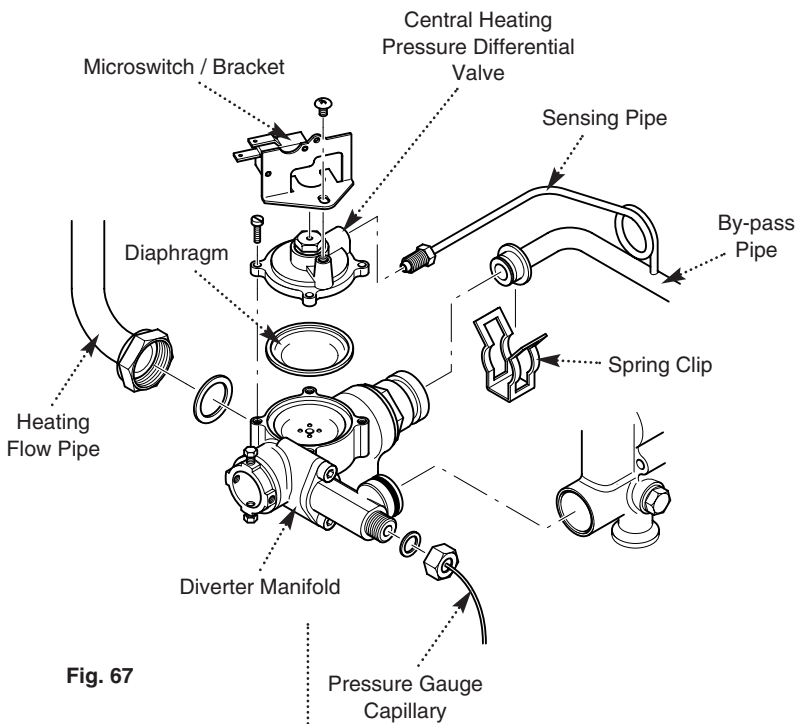

Fig. 67

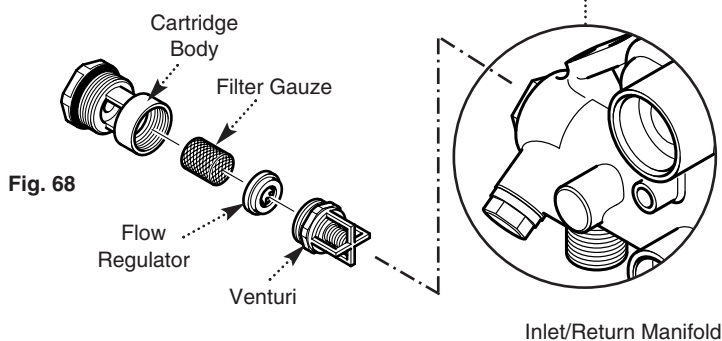
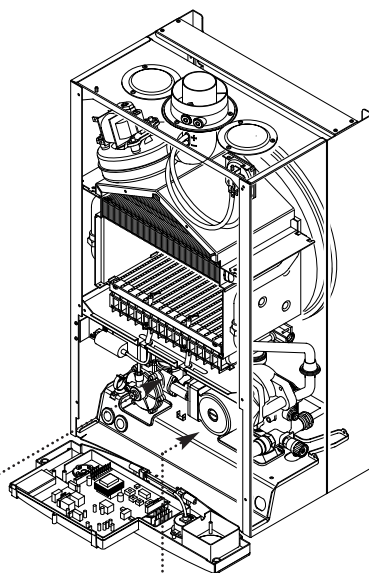
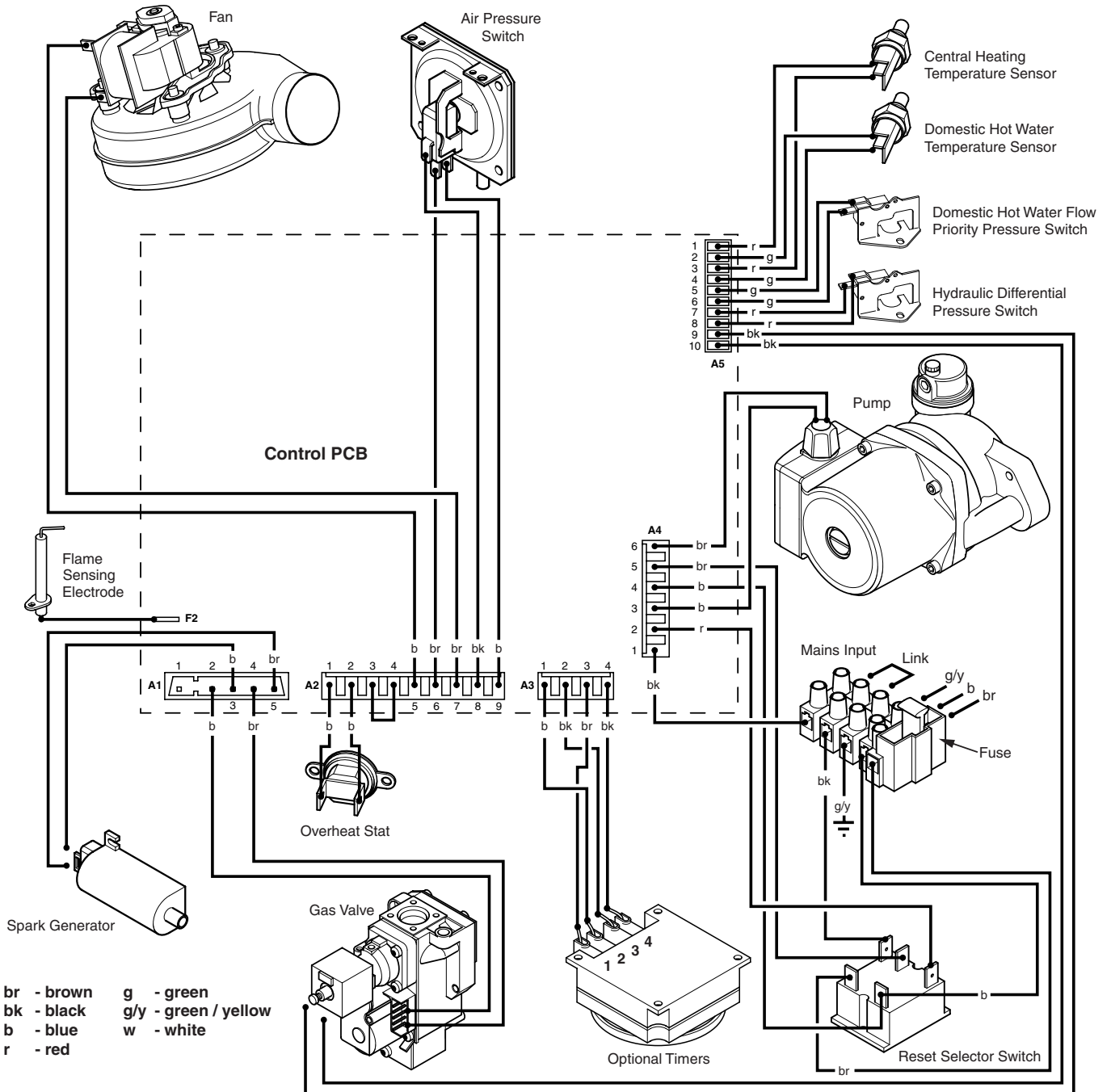

Fig. 68

Fig. 69

13.0 Illustrated Wiring Diagram



Carry out initial fault finding checks

1. Check that gas, water and electrical supplies are available at the boiler. Electrical supply = 230V ~ 50 Hz. CH water system pressurised to 0.5 bar when the boiler is cold. The preferred minimum gas pressure is 19.5mbar (natural gas), 27mbar (butane) or 36mbar (propane).
2. Carry out electrical system checks, i.e. Ground Continuity, Resistance to Ground, Short Circuit and Polarity with a suitable meter.
NOTE: These checks must be repeated after any servicing or fault finding.
3. Ensure all external controls are calling for heat and check all external and internal fuses. Before any servicing or replacement of parts ensure the gas and electrical supplies are isolated.

Refer to Section 13.0 "Illustrated Wiring Diagram" for position of numbered terminals
Central Heating - Follow operational sequence

NOTE: When instructed to turn the selector to the reset position turn the selector switch fully anticlockwise against the spring pressure to the reset position and hold for 2 seconds to reset the boiler.

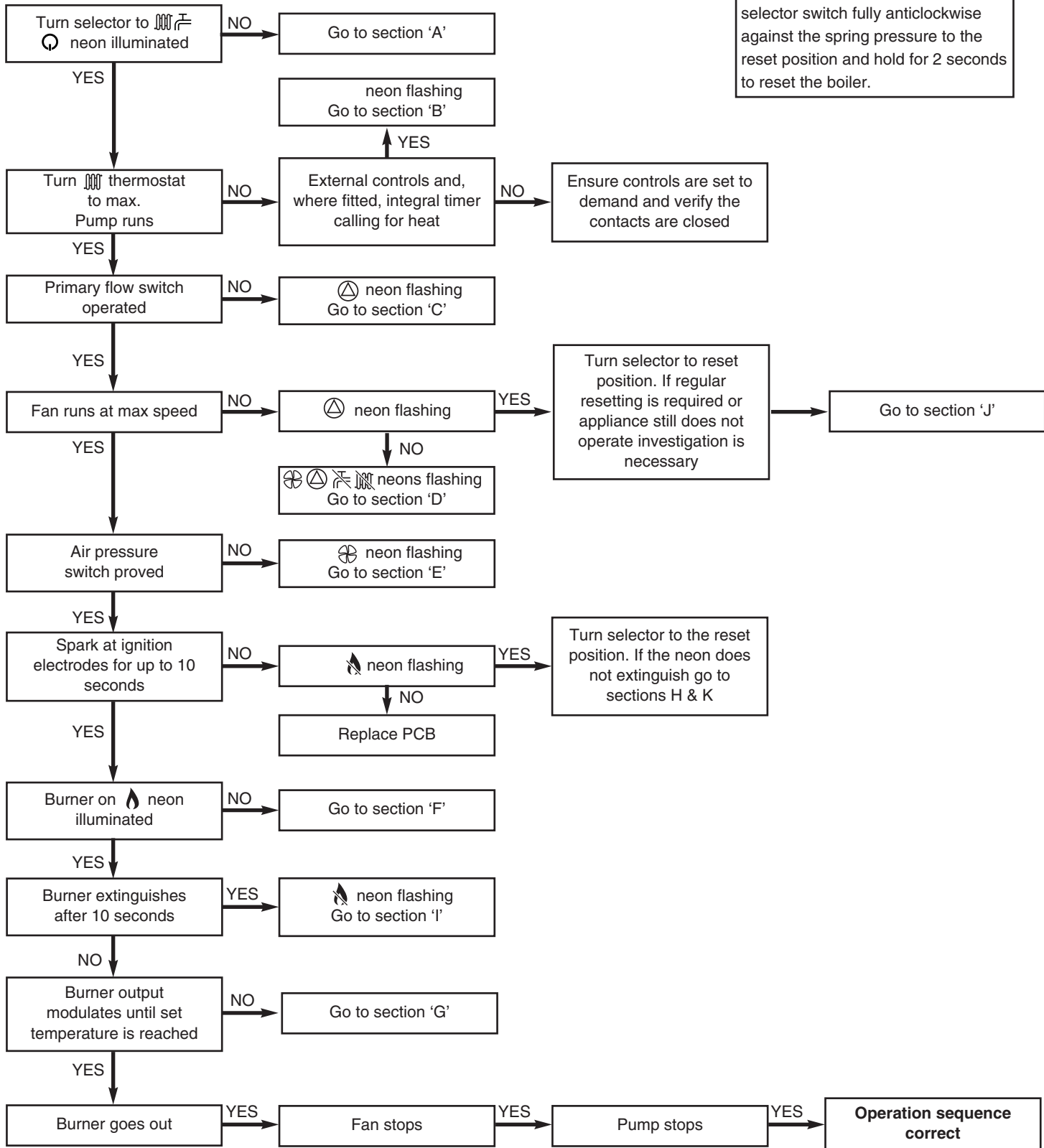

Fault Finding Solutions Sections A to E

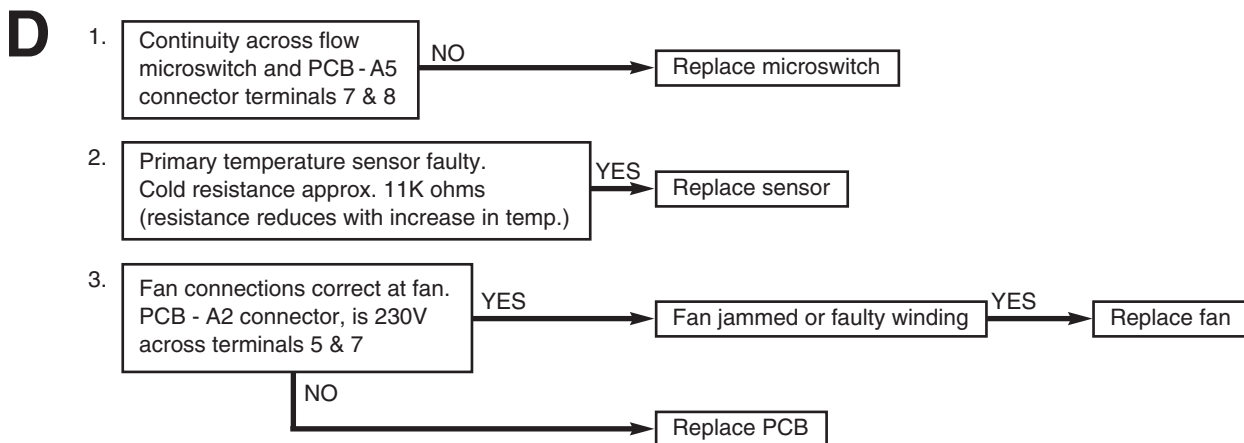
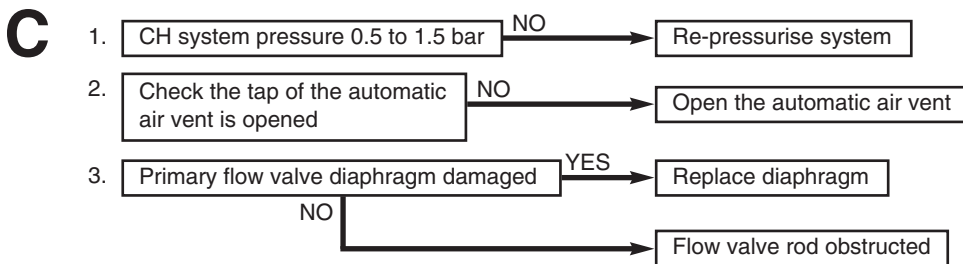
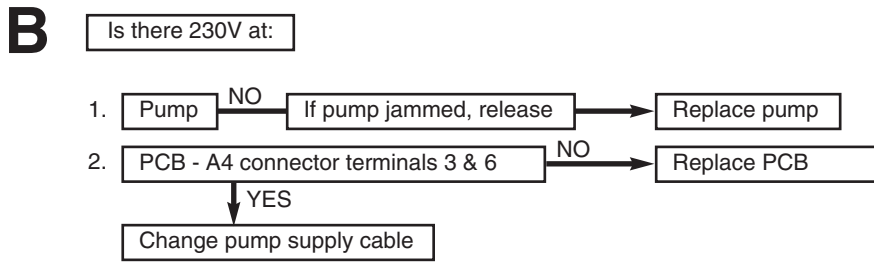
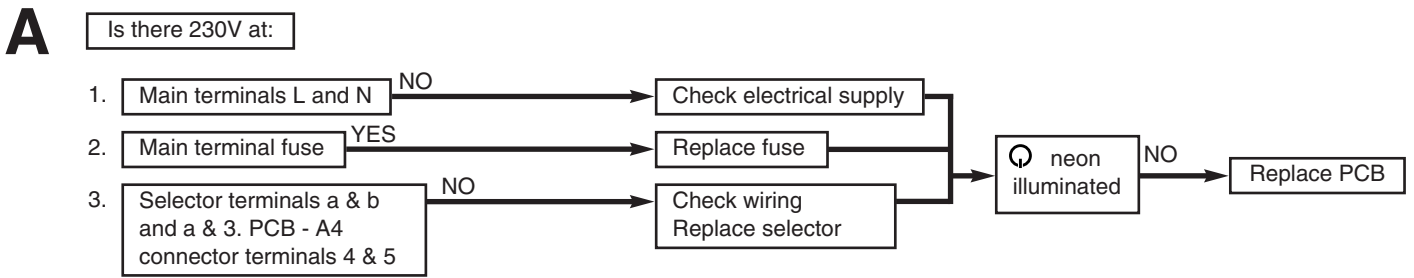

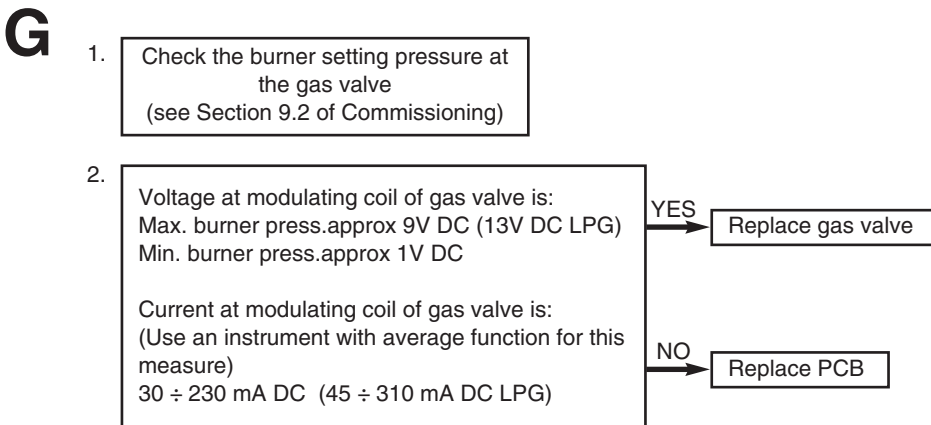
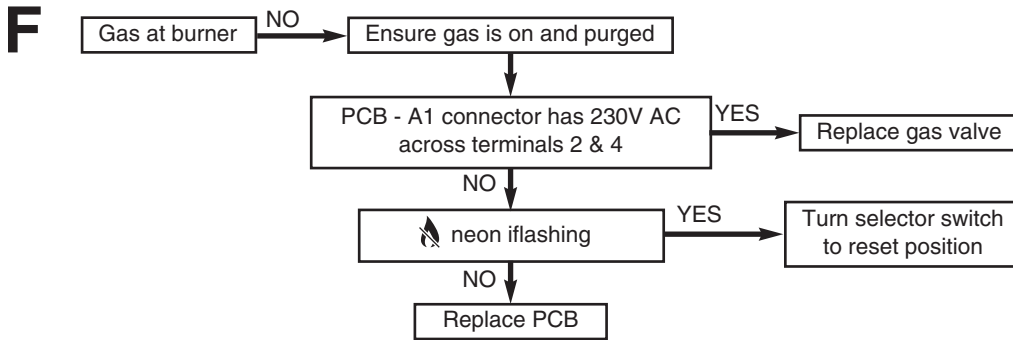
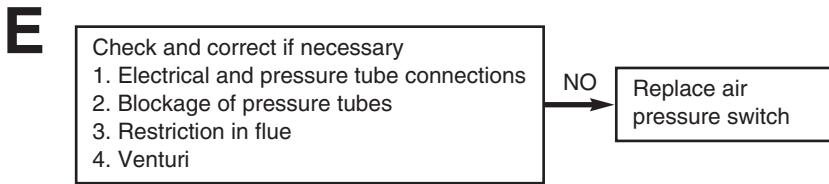

I

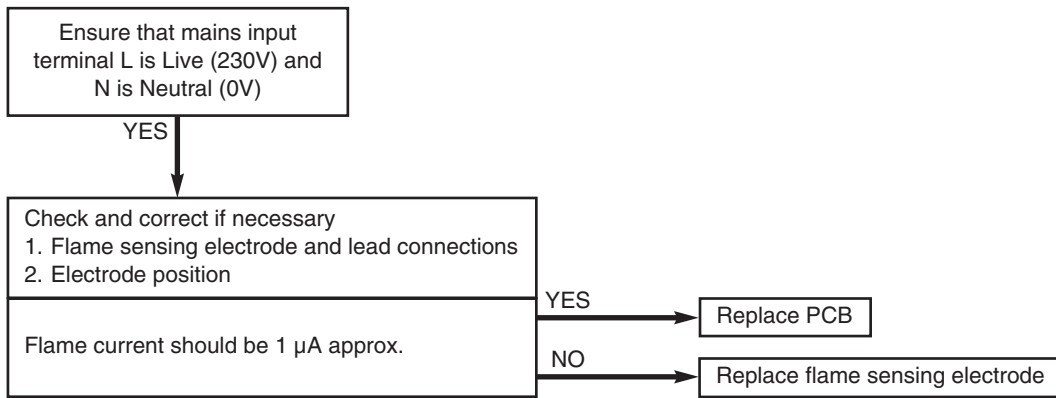

J

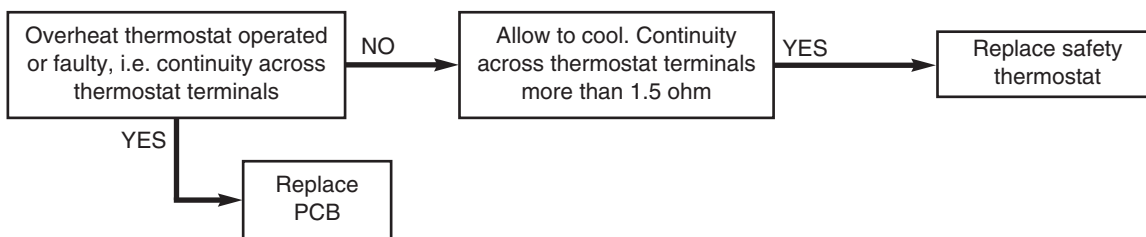

K

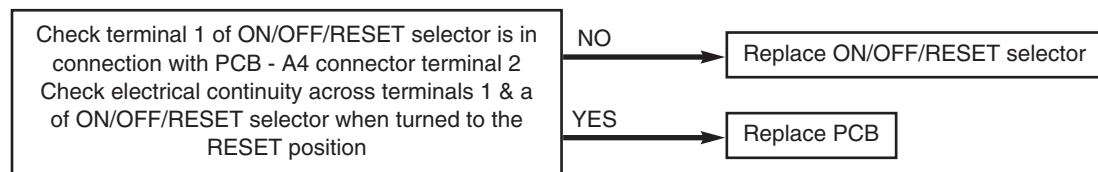

15.0 Short Parts List

Short Parts List

Key No.	G.C. No.	Description	Manufacturers Part No.
22	E66 527	Fan	248002
23	393 974	Pressure Switch	247380
32	E66 535	Heat Exchanger	248017
41	E66 399	Burner	248030
44	E66 402	Injector	248210
59	E66 408	Electrode Lead	248037
63	E66 411	Spark or Sensing Electrode	247384
72	E66 539	Pump (complete)	248042
101	E66 432	3-Way Valve Assy.	248061
131	342 571	Temperature Sensor	247394
135	E66 439	Safety Thermostat	248079
140	343 560	Gas Valve	248085
154	E66 459	PCB	248074
169	E66 453	Pressure Gauge	248090

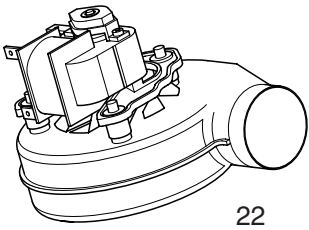

22

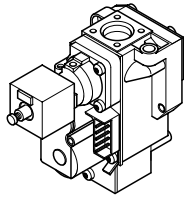

140



44

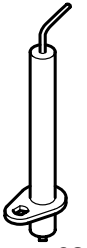

63



131



135

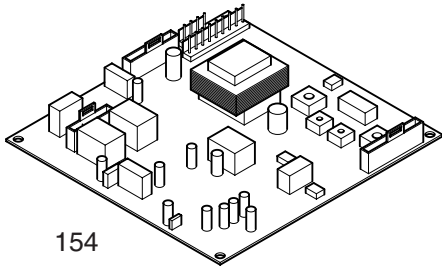

154

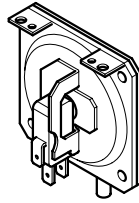

23

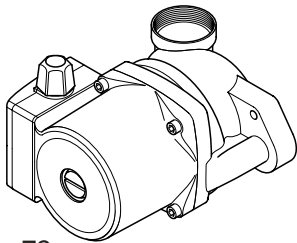

72

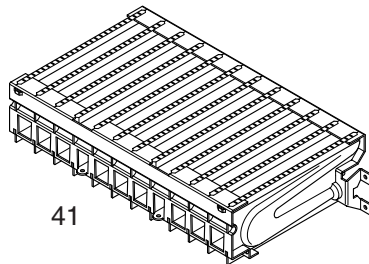

41

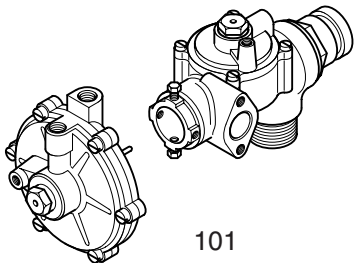

101

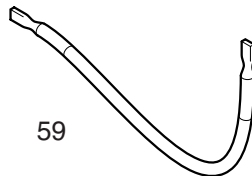

59

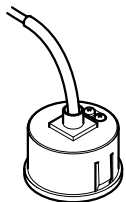

169

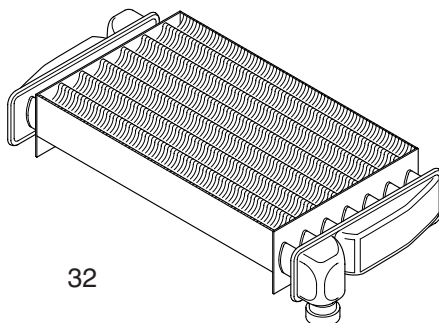

32

POTTERTON

Potterton, Baxi UK Limited, Brownedge Road, Bamber Bridge, Preston, Lancashire. PR5 6SN
After Sales Service 08706 096 096 Technical Enquiries 08706 049 049
www.baxi.com