

CE

The CP-G Range

Installation & Servicing Instructions

WARNING: THIS APPLIANCE MUST BE EARTHED

£1.00 When supplied separately.

CP-G. Issue 5

CONTENTS

<i>Section</i>	<i>Title</i>	<i>Page</i>
1.	Introduction	2
2.	Technical Data	3
3.	General Requirements	6
4.	Installation	7
5.	Air Distribution System	8
6.	Commissioning & Testing	8
7.	Servicing	11
8.	Connections to Powmatic External Controls	12
9.	Fault Finding	13
10.	Short List of Parts	14

<i>Tables</i>	<i>Title</i>	<i>Page</i>
1a.	Dimensions (S.I. Units)	3
1b.	Dimensions (Imperial Units)	3
2a.	Specifications (S.I. Units)	4
2b.	Specifications (Imperial Units)	4
3.1	Burner Pressures - Natural Gas Group H - G20	4
3.2	Burner Pressures - Propane - G31	5
4.	Electrical Loadings	5

<i>Figure</i>	<i>Title</i>	<i>Page</i>
1a.	Gas Control Schematic CP-G 100 - 300	9
1b.	Gas Control Schematic CP-G 400 - 1250	9
2a.	Gas Controls Layout CP-G 100, 150	10
2b.	Gas Controls Layout CP-G 200, 300	10
2c.	Gas Controls Layout CP-G 400, 1250	10
3.	Honeywell VL4064N	12
4.	White Rodgers 5F464	12

<i>Appendix</i>	<i>Title</i>	<i>Page</i>
A	Calculation of Flue System Equivalent Resistance	15

1. INTRODUCTION

The Powrmatic CP-G range of gas fired forced draught, closed flue, fanned circulation air heaters cover a heat output range of 29.3 kW (100000 Btu/h) to 366.4 kW (1250000 Btu/h) and are intended primarily for heating commercial or industry premises. They are certified for use on Natural Gas, Group H - G20 and Propane - G31.

All models are for floor mounting and are available in UF and UD variants. (U - Upright; F - Freeblowing; D - Ducted).

CP-G heaters have a centrifugal fan assembly fitted upstream of the combustion chamber / heat exchanger assembly to circulate the air being heated.

Heaters are fitted as standard with fully automatic monoblock forced draught gas burners and monoblock gas control assemblies.

Options include High/Low or modulating burners, Deep V filters, proportional air dampers, combustion air inlet adaptors and inlet and outlet duct spigots.

Each air heater must be connected to a closed flue system only.

Gas Safety (Installation & Use) Regulations 1994

It is law that all gas appliances are installed, adjusted and, if necessary, converted by qualified persons* in accordance with the above regulations. Failure to install appliances correctly can lead to prosecution. It is in your own interests and that of safety to ensure that the law is complied with.

* e.g. Corgi Registered

2 Technical Data

2.1 Dimensions

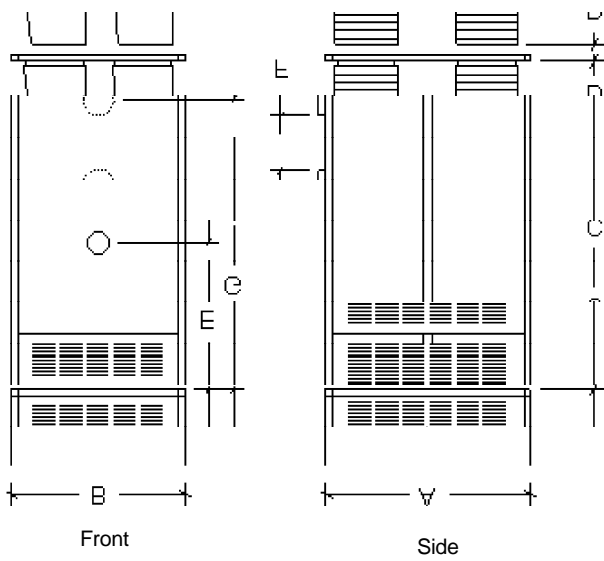

CP-G 1000 UF SHOWN

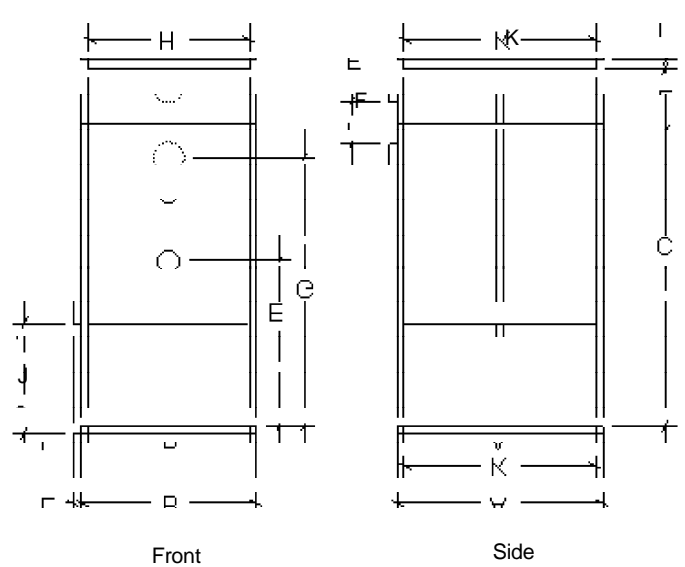

CP-G 1000 UD SHOWN

Table 1a. Dimensions (S.I. Units)

	A	B	C	D	E	F	G	H	J	K	L			
CP-G 100	730	603	1645	285	870	125	1360	502	533	629	51			
CP-G 150	806	629	1822		900		1518	527		705				
CP-G 200						150	1775	629	580	756				
CP-G 300	857	730	2076	373	1065							2058	525	
CP-G 400	1060	908	2356	457	1035							175		2155
CP-G 500						2457	445	1127	1562					
CP-G 600										1365			356	
CP-G 700	1162	2381	445	1300	200	2045	1062	686	1264					
CP-G 800										1670				
CP-G 1000	1162	2381	445	1300	200	2045	1062	686	1560					
CP-G 1250														

Table 1b. Dimensions (Imperial Units)

	A	B	C	D	E	F	G	H	J	K	L		
CP-G 100	28 ³ / ₄	23 ³ / ₄	64 ³ / ₄	11 ¹ / ₄	34 ³ / ₄	5	53 ¹ / ₂	19 ³ / ₄	21	24 ³ / ₄	2		
CP-G 150	31 ³ / ₄	24 ³ / ₄	71 ³ / ₄	11 ¹ / ₂	35 ¹ / ₂		59 ³ / ₄	20 ³ / ₄		27 ³ / ₄			
CP-G 200						6	69 ³ / ₄	24 ³ / ₄	23	29 ³ / ₄			
CP-G 300	33 ³ / ₄	28 ³ / ₄	81 ³ / ₄	14 ³ / ₄	42							81	20 ³ / ₄
CP-G 400	41 ³ / ₄	35 ³ / ₄	92 ³ / ₄	18	40 ³ / ₄							7	
CP-G 500						96 ³ / ₄	17 ³ / ₄	44 ¹ / ₂					
CP-G 600									53 ³ / ₄	14			16
CP-G 700	45 ³ / ₄	93 ³ / ₄	17 ¹ / ₂	51	8	80 ¹ / ₂	41 ³ / ₄	27				49 ³ / ₄	
CP-G 800													
CP-G 1000	65 ³ / ₄												
CP-G 1250		45 ³ / ₄	93 ³ / ₄	17 ¹ / ₂	51	8	80 ¹ / ₂	41 ³ / ₄	27	61 ³ / ₄			

Table 2a - Specifications (S.I. Units)

MODEL	HIGH FIRE		LOW FIRE		AIR VOLUME	MAXIMUM DUCT RESISTANCE		FAN MOTOR		GAS CONNECTION SIZE	WEIGH kg
	INPUT (Nett)	OUTPUT	INPUT (Nett)	OUTPUT		Standard	L.H.P.	Standard	L.H.P.		
	kw		kw			m³/s	pa		kw		
CP-G 100	32.1	29.3	N/A	N/A	0.5192	150	N/A	0.335	N/A	Rc½	126
CP-G 150	48.4	44.0	N/A	N/A	0.7788	290	N/A	0.55	N/A		137
CP-G 200	67.0	58.6	N/A	N/A	1.0383	200	N/A	0.56	N/A	Rc¾	163
CP-G 300	103.0	88.0	N/A	N/A	1.5575	250	N/A	1.5	N/A		204
CP-G 400	133.7	117.2	N/A	N/A	2.0766	150	N/A	2.2	N/A		330
CP-G 500	168.9	146.5	N/A	N/A	2.9736	210	240	2.2	3.3		355
CP-G 600	202.3	175.8	N/A	N/A	3.4000	190	250	3.3	5.5		435
CP-G 700	237.8	205.1	N/A	N/A	3.9647	100	200	4.0	5.5	Rc1½	530
CP-G 800	266.5	234.5	N/A	N/A	4.5075	N/A	150	3.3	5.5		550
CP-G 1000	333.1	293.1	N/A	N/A	5.1919	50	100	5.5	7.5		556
CP-G 1250	413.8	366.4	N/A	N/A	6.4866	300	N/A	11.0	N/A		670

Table 2b - Specifications (Imperial Units)

MODEL	HIGH FIRE		LOW FIRE		AIR VOLUME	MAXIMUM DUCT RESISTANCE		FAN MOTOR		GAS CONNECTION SIZE	WEIGH lb
	INPUT (Gross)	OUTPUT	INPUT (Gross)	OUTPUT		Standard	L.H.P.	Standard	L.H.P.		
	Btu/h		Btu/h			ft³/m	in wg		hp		
CP-G 100	121695	100000	N/A	N/A	1100	0.60	N/A	0.45	N/A	½"BSP	278
CP-G 150	183490	150000	N/A	N/A	1650	1.16	N/A	0.75	N/A		302
CP-G 200	254004	200000	N/A	N/A	2200	0.80	N/A	0.75	N/A	¾"BSP	360
CP-G 300	390484	300000	N/A	N/A	3300	1.00	N/A	2.0	N/A		450
CP-G 400	506871	400000	N/A	N/A	4400	0.60	N/A	3.0	N/A		727
CP-G 500	640318	500000	N/A	N/A	6300	0.84	0.96	3.0	4.5		782
CP-G 600	766942	600000	N/A	N/A	7200	0.76	1.00	4.5	7.5		959
CP-G 700	901526	700000	N/A	N/A	8400	0.40	0.80	5.3	7.5	1½"BSP	1166
CP-G 800	101033	800000	N/A	N/A	9550	N/A	0.60	4.5	7.5		1213
CP-G 1000	126281	100000	N/A	N/A	11000	0.2	0.40	7.5	10.0		1226
CP-G 1250	156876	125000	N/A	N/A	13360	1.2	N/A	15.0	N/A		1477

Table 3.1 Burner Pressures - Natural Gas - Group H - G20 - Net CV (H_i) = 34.02MJ/m³

MODEL	Powmatic Burners			Riello Burners			Gas Rate	
	Type	Start Gas Pressure	Main Burner Pressure	Type	Start Gas Pressure	Main Burner Pressure		
		mbar	mbar		mbar	mbar	m³/h	ft³/h
CP-G 100	PCGS 2	N/A	4.8	GS 5	N/A	4.3	3.40	120.1
CP-G 150	PCGS 2	N/A	9.9	GS 10	N/A	4.2	5.12	180.8
CP-G 200	PCGS 3	N/A	12.2	GS 10	N/A	3.7	7.08	250.0
CP-G 300	PCGS 5	N/A	10.4	GS 10	N/A	5.2	10.89	384.6
CP-G 400	PCGS 5	1.5	8.8	GS 20	2.4	4.2	14.14	499.3
CP-G 500	PCGS 5	1.7	9.0	GS 20	3.4	6.3	17.86	630.7
CP-G 600	PCGS 8	2.5	8.1	GS 20	2.8	6.0	21.39	755.4
CP-G 700	PCGS 13	3.3	6.8	GAS 3	2.5	6.7	25.15	888.2
CP-G 800	PCGS 13	0.8	5.4	GAS 3	1.1	7.1	28.20	995.9
CP-G 1000	PCGS 13	1.2	10.0	GAS 3	3.3	9.0	35.25	1244.8
CP-G 1250	PCGS 25	1.2	9.0	GAS 5	0.75	7.0	43.78	1546.1

Table 3.2 Burner Pressures - Propane - G31 - Net CV (H_i) = 88.00MJ/m³

MODEL	Powrmatic Burners			Riello Burners			Gas Rate	
	Type	Start Gas Pressure	Main Burner Pressure	Type	Start Gas Pressure	Main Burner Pressure		
		mbar	mbar		mbar	mbar		
CP-G 100	PCGS 2	N/A	6.9	GS 5	N/A	3.1	1.31	46.3
CP-G 150	PCGS 2	N/A	11.3	GS 10	N/A	6.4	1.98	69.9
CP-G 200	PCGS 3	N/A	20.0	GS 10	N/A	4.1	2.74	96.7
CP-G 300	PCGS 5	N/A	14.2	GS 10	N/A	8.3	4.21	148.7
CP-G 400	PCGS 5	3.5	23.4	GS 20	2.5	5.9	5.47	193.2
CP-G 500	PCGS 5	2.0	22.5	GS 20	3.7	8.5	6.90	243.7
CP-G 600	PCGS 8	1.2	22.7	GS 20	3.1	8.9	8.27	292.0
CP-G 700	PCGS 13	1.0	12.5	GAS 3	2.9	12.9	9.72	343.3
CP-G 800	PCGS 13	1.8	16.3	GAS 3	3.0	18.2	10.90	384.9
CP-G 1000	PCGS 13	4.5	26.0	GAS 3	2.5	17.5	13.62	481.0
CP-G 1250	PCGS 25	2.3	27.5	GAS 5	2.8	18.0	20.43	721.5

Table 4 Electrical Loadings

MODEL	ph	Standard					Larger Horsepower Motor					
		NOMINAL MOTOR R.P.M.	PLATE AMPS (A)	START AMPS (A)	RUN AMPS (A)	FUSE RATING (A)	NOMINAL MOTOR R.P.M.	PLATE AMPS (A)	START AMPS (A)	RUN AMPS (A)	FUSE RATING (A)	
CP-G 100	1	1000	2.6	5.0	2.6	3	N/A					
CP-G 150		1500	5.0	8.5	6.1	7						
CP-G 200		1000	4.1	10.0	4.5	5						
CP-G 300			7.0	18.0	8.1	10						
CP-G 400			6.7	14.0	6.0	7						
CP-G 500	3	1500	5.2	24.0	5.4	7	1500	7.6	25.0	7.2	10	
CP-G 600			7.6	30.0	7.2	10		12.0	35.0	11.5	15	
CP-G 700			9.0	35.0	8.9	10		12.0	35.0	11.8	15	
CP-G 800			7.6	25.0	6.8	10		12.0	35.0	11.6	15	
CP-G 1000			12.0	35.0	12.8	15		15.5	32.0	14.2	15	
CP-G 1250			19.7	33.0	19.0	20		N/A				

3. General Requirements

3.1 Related Documents

The installation of the air heater(s) must be in accordance with the rules in force and the relevant requirements of the Gas Safety Regulations, Building Regulations and the I.E.E. Regulations for Electrical Installations.

It should be in accordance also with any relevant requirements of the local gas region, local authority and fire authority and the relevant recommendations of the following documents.

British Gas Plc Publications

IM/11 : 1989 Flues for Commercial and Industrial Gas Fired Boilers and Air Heaters

IM/16 : 1988 Guidance notes for the installation of gas pipework, boosters and compressors in Customer's premises (excluding domestic installation of 25mm and below).

British Standards Code of Practice

BS 5588 Fire precautions in the design and construction of buildings.

Part 2 : 1985 Code of Practice for Shops

Part 3 : 1983 Code of Practice for Office Buildings

BS 6230: 1991 Installation of Gas Fired Forced Convection

Air Heaters for Commercial and Industrial Space Heating.

Those appliances having an input rating not exceeding 60kW viz. CP-G 100 and CP-G 150 must be installed in accordance with the relevant recommendations of the following documents. BS 5440 Flues and Air Supply for gas appliances of rated input not exceeding 60kW (1st and 2nd family gases).

Part 1 - Flues, Part 2 - Air Supply

For CP-G 100 and CP-G 150 units reference should also be made to BS 5864. Code of Practice for installation of gas-fired ducted-air heaters of rated input not exceeding 60kW.

3.2 Location

The location chosen for the air heater must permit the provision of a satisfactory flue system and an adequate air supply. The location must also provide adequate space for servicing and air circulation around the air heater.

The heater(s) must not be installed in conditions for which it is not specifically designed e.g. where the atmospheric is corrosive or salty and where high wind speeds may affect burner operation, and they are not suitable for outdoor use.

Where the location of the air heater is such that it might suffer external mechanical damage e.g. from overhead cranes, fork lift trucks, it must be suitably protected.

CP-G units are designed to operate in a maximum ambient temperature of 25 °C.

3.3 Gas Supply

3.3.1 Service Pipes

The local gas undertaking should be consulted at the installation planning stage in order to establish the availability of an adequate supply of gas. An existing service pipe must not be used without prior consultation with the local gas undertaking.

3.3.2 Meters

A gas meter is connected to the service pipe by the local gas undertaking or a local gas undertaking contractor. An existing meter should be checked, preferably by the gas undertaking, to ensure that the meter is adequate to deal with the total rate of gas supply required.

3.3.3. Installation Pipes

Installation pipes should be fitted in accordance with IM/16:1988. Pipework from the meter to the air heater must be of adequate size. Do not use pipes of a smaller size than the inlet gas connection of the heater. The complete installation must be tested for soundness as described in the above Code. The complete installation must be tested for soundness as described in BS 6230.

3.3.4. Boosted Supplies

Where it is necessary to employ a gas pressure booster the controls must include a low pressure cut off switch at the booster inlet. The local gas undertaking must be consulted before a gas pressure booster is fitted.

3.4 Flue System

Detailed recommendations for fluing are given in BS 5440, Part 1 (Flues) and IM/11.

The air heater must be connected to a closed flue system. The cross sectional area of the flue serving the appliance must be not less than the area of the flue outlet to the air heater.

Materials used for the flue system should be mechanically robust, resistant to internal and external corrosion, noncombustible and durable under the conditions to which they are likely to be subjected.

Prevention of condensation within the flue should be an important factor in the design of the flue system. In order to minimise condensation the use of double walled flue pipe or insulation is recommended. If double walled flue pipe is used it should be of an acceptable type.

Where condensation in the flue is unavoidable provision should be made for condensation to flow freely to a point at which it can be released, preferably into a gully. The condensation pipe from the flue to the disposal point should be of non-corrodible material of not less than 22mm (1/2") size. Facilities should be made for disconnecting the flue pipe(s) from the air heater(s) for inspection and servicing purposes. Bends with removable covers should be fitted for inspection and cleaning purposes where considered appropriate.

The flue should terminate in a freely exposed position and must be so situated as to prevent the products of combustion entering any opening in a building in such concentration as to be prejudicial to health or a nuisance.

It is recommended that consideration be given to the fitting of a terminal at the flue outlet, however, where the heater flue is less than 200mm (8") in diameter an approved terminal must be fitted.

3.5 Air Supply

In buildings having a design air change rate of less than 0.5 /h, and where CP-G heaters are to be installed in heated spaces having a volume less than 4.7 m³ /kW of total rated heat input grilles shall be provide at low level as follows:-

- (1) for heaters of heat input less than 60 kW, the total minimum free area shall not be less than 4.5 cm² per kilowatt of rated heat input.
- (2) for heaters of heat input 60 kW or more, the total minimum free area shall not be less than 270cm² plus 2.25 cm² per kilowatt in excess of 60 kW rated heat input.

The air vent(s) should have negligible resistance and must not be sited in any position where it is likely to be easily blocked or flooded or in any position adjacent to an extraction system which is carrying flammable vapour.

Where the air heater(s) is to be installed in a plant room the air heater(s) requires the plant room housing it to have permanent air vents communicating directly with the outside air, at high level and at low level. Where communication with the outside air is possible only by means of high level air vents, ducting down to floor level for the lower vents should be used.

Air vents should have negligible resistance and must not be sited in any position where they are likely to be easily blocked or flooded or in any position adjacent to an extraction system which is carrying flammable vapour.

Grilles or louvres should be so designed that high velocity air streams do not occur within the plant room.

The basic minimum effective area requirements of the air vents are as follows:

- (a) **Low Level (inlet)**
 - (1) for heaters of total rated heat input less than 60 kW: 9 cm² per kilowatt of rated heat input
 - (2) for heaters of total rated heat input 60 kW or more: 540 cm² plus 4.5 cm² per kilowatt in excess of 60 kW total rated input.
- (b) **High Level (outlet)**
 - (1) for heaters of total rated heat input less than 60 kW: 4.5 cm² per kilowatt of rated heat input;
 - (2) for heaters of total rated heat input 60 kW or more: 270 cm² plus 2.25 cm² per kilowatt in excess of 60kW total rated input.

3.6 Air Distribution System

The following notes are of particular importance.

For free-blowing units it must be taken into account that the buoyancy of the heated air leaving the heater and air patterns within the space being heated will modify the air throw pattern achieved. In buildings having a low heat loss where single units are required to cover a large floor area and in buildings with high roof or ceiling heights Calecon thermal economiser units should be fitted to ensure even heat distribution and minimise stratification respectively. Care should be taken to avoid impeding the air throw with racking, partitions, plant or machinery etc. Various outlet configurations are available as optional extras to modify the air throw pattern to suit particular site conditions.

For ducted units all delivery and return air ducts, including air filters, jointing and any insulation or lining must be constructed entirely of materials which will not contribute to a fire, are of adequate strength and dimensionally stable for the maximum

internal and external temperatures to which they are to be exposed during commissioning and normal operation. In the selection of materials account must be taken of the working environment and the air temperatures which will result when the overheat limit thermostat is being commissioned. Where inter-joint spaces are used as duct routes they should be suitably lined with a fire-resisting material.

A full and unobstructed return air path to the air heater(s) must be provided.

If the air heater(s) is installed in a plant room the return air intake(s) and the warm air outlet(s) from the heater(s) must be fully ducted, in to and out of the plant room to avoid interference with the operation of the flue by the air circulation fan.

The openings in the structure of the plant room through which the ducting passes must be fire stopped.

Care must be taken to ensure that return-air intakes are kept clear of sources of smells and fumes, and in special circumstances where there is any possibility of pollution of the air by dust, shavings etc., precautions must be taken by carefully positioning return air intakes and by the provision of screens to prevent contamination.

In addition, where there is a risk of combustible material being placed close to the warm air outlets, suitable barrier rails should be provided to prevent any combustible material being within 900mm (3ft) of the outlets.

3.7 Electrical Supply

Wiring external to the air heater must be installed in accordance with the I.E.E. Regulations for Electrical Installations and any local regulations which apply. Wiring should be completed in flexible conduit.

Heaters CP-G 100 - CP-G 300 are supplied by 230V - 1ph, 50Hz., the remaining heaters by 400V - 3ph, 50Hz. The method of connection to the main electricity supply must facilitate the complete electrical isolation of the air heater(s) and the supply should serve only the air heater(s).

The isolator must have a contact separation of at least 3mm in all poles. The method of connection should be provided adjacent to the air heater(s) in a readily accessible position. See the accompanying wiring diagram for the heater electrical connections

4. Installation of Air Heater(s)

4.1 General

Before installation, check that the local distribution conditions, nature of gas and pressure, and adjustment of the appliance are compatible.

The air heater must be installed in accordance with the rules in force and the relevant requirements of any fire regulations or insurance company's requirements appertaining to the area in which the heater is located, particularly where special risks are involved such as areas where petrol vehicles are housed, where cellulose spraying is carried out, in wood working departments etc.

Whichever method of mounting the air heater is used the following minimum clearances for installation and servicing must be observed.

To the front	The depth of the heater
To the rear	1.0m (3.3ft)
To at least one side	1.0m (3.3ft)
Above the heater	1.00m (3.3ft)

Any combustible material adjacent to the air heater and the flue system must be so placed or shielded as to ensure that its temperature does not exceed 65 °C (150 °F)

IMPORTANT:

1. No air heater shall be installed where there is a foreseeable risk of flammable particles, gases vapours or corrosion inducing gases or vapours being drawn into either the heated air stream or the air for combustion. In such cases installation may only proceed if the air to be heated and the air for combustion are ducted to the heater from an uncontaminated source preferably outside the building. In certain situations where only airborne particles are present it may suffice to fit filters on the air inlet ducts of the heater. Advice in these instances may be obtained from Powrmatic Ltd.

4.2 Fitting the Air Heater

Floor mounted heaters must be installed on a level noncombustible surface.

If noise levels are of particular importance the heater should be insulated from the structure of the building by installing it on suitable anti-vibration mountings. In all such cases it is essential that all gas, duct, electrical and flue connections to the heater are made with flexible connections to maintain continuity of connection. In the case of the flue connection single wall stainless steel flue is deemed to flex sufficiently to meet the requirements.

4.3 Connection of Air Heater(s) to Flue System

A single wall Tee piece is supplied with each heater and must be fitted to the flue outlet socket on the heater. The flue system then connects directly on to the tee. *For flue sizes refer to Tables 1a and 1b Page 3.* All units must be fitted with a flue having a minimum height, from the heater to the flue terminal, of 2m (6.5ft). Horizontal runs of flue are not permitted. If necessary a single offset using two 45° bends can be included to avoid obstructions. The maximum equivalent resistance of the flue system must not exceed 20 pa. Details of how to calculate the resistance of the flue to be installed are given in Appendix A.

4.4 Condensate Drainage

The design of the flue system should minimise the formation of condensation, however when this is envisaged to be a problem provision should be made for condensation to flow to a joint where it can be drained, preferably into a gully.

4.5 Gas Connection

A servicing valve and downstream union must be fitted at the inlet to the air heater gas controls assembly to facilitate servicing. The gas supply to the air heater must be completed in solid pipework and be adequately supported.

WARNING

When completing the final gas connection to the heater do not place undue strain on the gas pipework of the heater.

4.6 Electrical Connections

All units are fully pre-wired and only require final connections for the incoming mains supply and completion of the control circuit (230V) via a room thermostat, time clock etc. The electrical supply must be run to a point adjacent to the heater

and be suitably terminated to provide an isolation point that will prevent remote activation of the unit during servicing. The heater electrical panel is located behind the lower front panel and cable entry points are provided in the adjacent heater framework. Reference must be made to Table 4 (Page 5) to ascertain the electrical loading of the air heater(s) being installed so that cables of adequate cross-sectional area to safely carry that load are used for the electrical installation. The length of the conductors between the cord anchorage and the terminals must be such that the current carrying conductors become taut before the earth conductor if the cable or cord slips out of the cord anchorage. All external controls must be of an approved type.

See the wiring diagram accompanying these instructions.

5. Air Distribution System

5.1 General

CP-G *D models are designed for use with duct work to more precisely define the point of air delivery, and/or provide ducted return air or ducted fresh air inlet. All ducting must be independently supported of the air heater. Joints and seams of supply ducts and fittings must be securely fastened and made airtight.

5.2 Noise Reduction

If deemed necessary consideration should be given to mounting the heater on resilient pads, or equivalent, to minimise transfer of noise and vibration to the structure of the building.

It is recommended that ducting should be connected to the heater spigots via an airtight flexible coupling of noncombustible material. Before fitting coupling it must be ensured that a maximum clearance of 13mm (1/2") will be maintained between the ends of the ducting and the heater spigots.

If required sound attenuators may be fitted in inlet and outlet ducts to reduce airborne fan noise. Materials used in outlet sound attenuators must be capable of withstanding 100 °C air temperature without any deterioration.

5.3 Room Thermostat Siting

The room thermostat should be fitted at a point which will be generally representative of the heated area as far as temperature is concerned. Draughty areas, areas subjected to direct heat e.g. from the sun, and areas where the air movement is relatively stagnant e.g. in recesses, are all positions to be avoided for siting the thermostat.

The thermostat should be mounted about 1.5m (5ft) from the floor.

Any room thermostat, frost thermostat, time clock etc. must be suitable for switching 230V, 5A and must be of the 'snap action' type to minimise contact bounce.

For electrical connections of external controls see the accompanying wiring diagram.

6. Commissioning & Testing

6.1 Electrical Installation

Checks to ensure electrical safety must be carried out by a competent person.

6.2 Gas Installation

The whole of the gas installation, including the meter, should be inspected and tested for soundness and purged in accordance with the recommendations of IM/16:1988.

6.3 Air Distribution System

The system should be checked to ensure that the installation work has been carried out in accordance with the design requirements.

Particular attention should be given to the correct arrangement of delivery ducts and registers, return air ducts and grills and general adequacy of return air paths.

For CP-G *D heaters ensure that the total duct system resistance does not exceed the available air pressure of the equipment supplied refer to Table 2a & 2b (Page 4). If the duct system resistance is less than the available air pressure of the equipment supplied additional resistance must be introduced e.g. by adjustment of duct outlet nozzles and balancing of the duct system.

6.4 Lighting the Air Heater

6.4.1 Gas Controls Assembly - Soundness Check

1. Ensure the gas service valve at the inlet to the gas controls assembly is shut.

2. To prove soundness of the first main safety shut-off valve and first start gas safety shut-off valve:-

- a) Connect pressure gauge to the inlet pressure test point on the main valve block or inlet pipework.
- b) Open gas service valve and allow pressure to stabilise before shutting it again. The valves are sound if no pressure drop is observed. If a pressure drop is observed do not proceed until the fault has been rectified. Remove pressure gauge and refit sealing screw in pressure test point.

6.4.2 Sequence Check

1. Ensure that the gas service valve is **closed** and that the main electrical supply to the heater is switched off.

2. Check that all external controls are either "ON" or at "MAX"

3. Turn "ON" the main electrical supply and check that the following sequence of events occurs.

- i) Burner fan runs
 - ii) Ignition spark is heard
 - iii) Start gas valves open (Main gas valves on CP-G100 - 300.
 - iv) Burner goes to lockout as there is no gas supply.
4. Switch off main electricity supply.

6.4.3 Final Adjustment

6.4.3.1 CP-G 100 - 300

IMPORTANT: The maximum flow and start flow adjustments provided on the GM main gas block valve assembly (Fig 2b - 4) are not used and must not be adjusted.

1. Remove the sealing screw from the pressure test point located on the side of the gas inlet to the burner head and attach a pressure gauge. Remove the sample point cover plug from the outlet flue length and insert a CO₂ measuring instrument.

2. Turn "ON" the main electricity supply and check that the following sequence of events occur.

- i) Burner fan runs.

- ii) Ignition spark is heard.
 - iii) Main gas valves open and Main gas flame is established.
3. Check that the main burner gas pressure agrees with that in Tables 3.1 or 3.2. If necessary adjust the main burner gas pressure (Fig 2a - 3 or Fig 2b - 2).
 4. Measure the CO₂ content of the flue gases. If necessary adjust the combustion air damper of the burner (Refer to the Burner Supplement) to obtain a reading of 9.0 - 9.5%
 5. Turn "OFF" the main electricity supply, remove pressure gauge and refit sealing screw in pressure test point and flue sample point cover plug.

6.4.3.2 CP-G 400 - 2000

IMPORTANT: The maximum flow and start flow adjustments provided on the GM main gas block valve assembly (Fig 2c - 4) are not used and must not be adjusted.

1. Remove the sealing screw from the pressure test point located on the side of the gas inlet to the burner head and attach a pressure gauge. Remove the sample point cover plug from the outlet flue length and insert a CO₂ measuring instrument.
2. Remove the electrical cover from the downstream main gas valve and pull apart the inline connector.
3. Turn "ON" the main electricity supply and check that the following sequence of events occur.
 - i) Burner fan runs.
 - ii) Ignition spark is heard.
 - iii) Start gas valves open.

- iv) Start gas flame is established.
4. Check that the start gas pressure agrees with that in Tables 3.1 or 3.2. If necessary adjust the start gas pressure (Fig 2c - 5).
 4. Turn "OFF" the main electricity supply.
 5. Reconnect the inline connector and refit valve electrical cover.
 6. Turn "ON" the main electrical supply and the burner will run through its sequence until main flame is established. Check that the main burner gas pressure agrees with that in Tables 3.1 or 3.2. If necessary adjust the main burner gas pressure (Fig 2c - 3).
 7. Measure the CO₂ content of the flue gases. If necessary adjust the combustion air damper of the burner (Refer to the Burner Supplement) to obtain a reading of 9.0 - 9.5%.
 8. Remove pressure gauge, refit sealing screw in pressure test point and flue sample point cover plug.

6.4.4 Final Soundness Test

1. After making final gas rate checks all joints on the gas controls assembly must be tested for soundness using leak detection fluid.

6.4.5 Flame Safeguard

1. Whilst the burner is in operation close the gas service valve. The burner should go to lockout within 1 second.

6.5 Handing over the Air Heater

Hand the Users Instructions to the user or purchaser for retention and instruct in the efficient and safe operation of the air heater

Gas Controls Schematics

Fig 1a CP-G 100 - 300

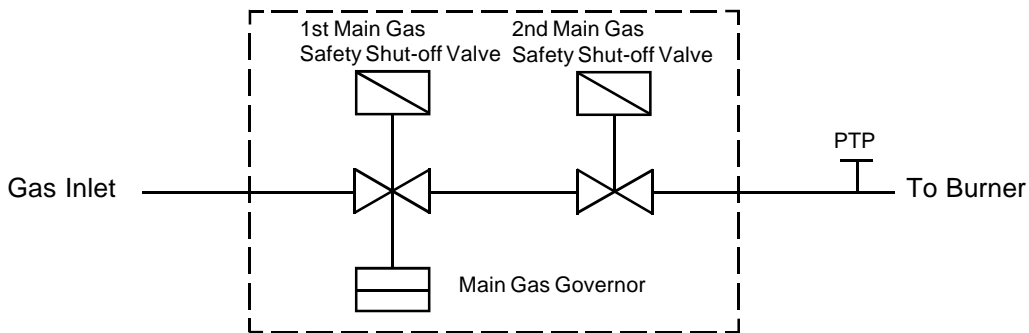

Fig 1b CP-G 400 - 1250

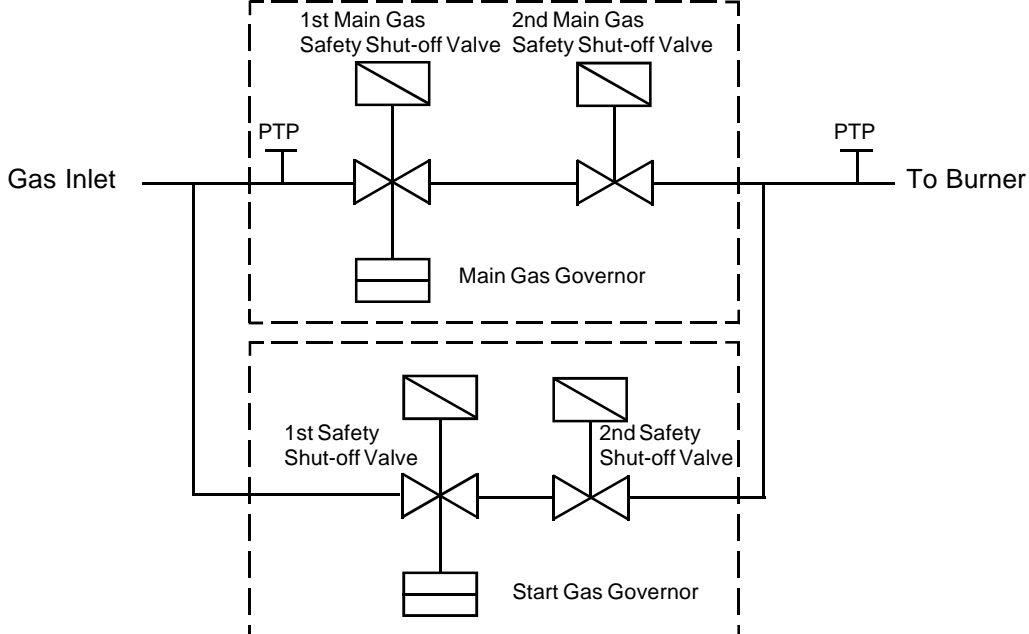

Fig 2a Gas Controls Layout CP-G 100, 150

- 1) 1st Main gas safety shut off valves.
- 2) 2nd Main gas safety shut off valves.
- 3) Main burner pressure adjustment screw.

Notes:-

- i) Electrical connection plugs not shown.

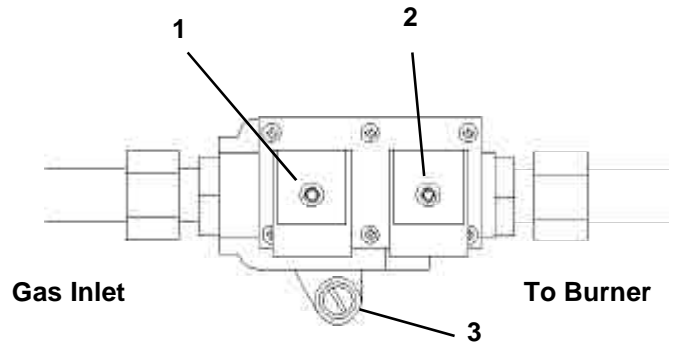

Fig 2b Gas Controls Layout CP-G 200, 300

- 1) Main gas safety shut off valves.
- 2) Main burner pressure adjustment screw.
- 3) Inlet Pressure test point.
- 4) Flow rate and valve opening speed adjustments.

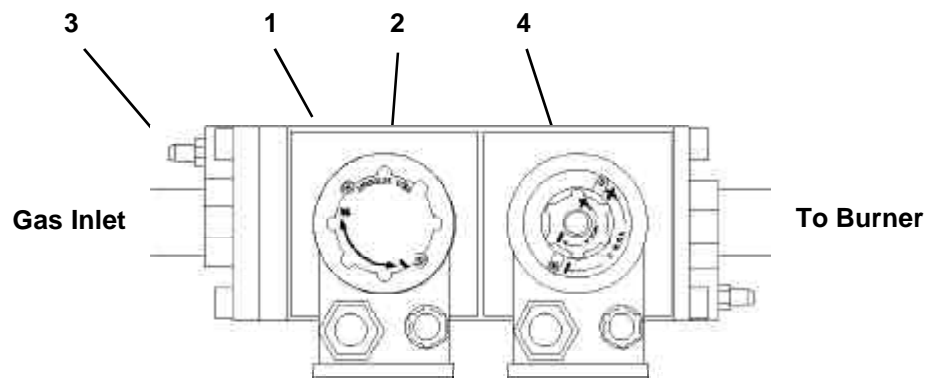
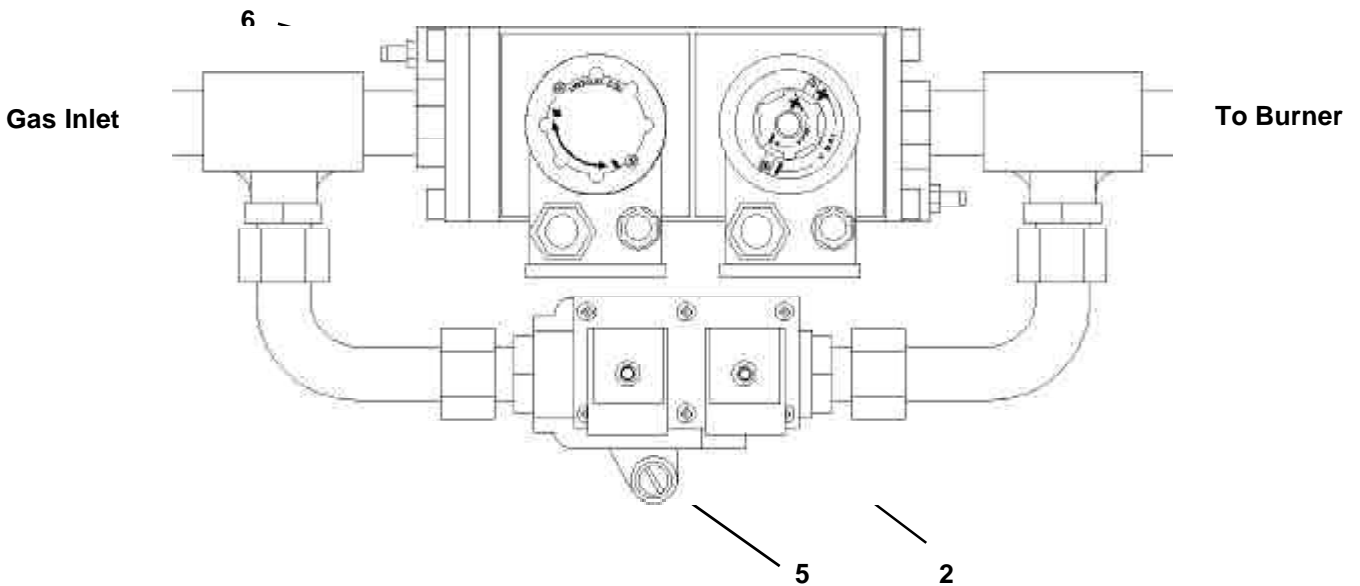

Fig 2c Gas Controls Layout CP-G 400 - 2000



- 1) Main gas safety shut off valves.
- 2) Start gas safety shut off valves.
- 3) Main burner pressure adjustment screw.
- 4) Flow rate and valve opening speed adjustments.
- 5) Start gas pressure adjustment screw.
- 6) Pressure test point.

and associated controls.

Adjust the automatic controls to those values required by the User.

Finally, advise the user or purchaser that, for continued efficient and safe operation of the air heater, it is important that servicing is carried out annually.

In the event that the premises are not yet occupied turn off the gas and electricity supplies and leave instructional literature adjacent to gas meter.

7. Servicing

WARNING: Always switch off and disconnect electricity supply and close the gas service valve before carrying out any servicing work or replacement of failed components.

7.1 General

Full maintenance should be undertaken not less than once per year. After any servicing work has been complete or any component replaced the air heater(s) must be fully commissioned and tested for soundness as described in Section 6.

7.2 Burner Maintenance

1. Refer to the Burner Supplement supplied with the heater.

Note: Any references therein to the gas controls assembly should be ignored.

7.3 Heat Exchanger Cleaning

1. Disconnect the gas supply at the inlet to the gas controls assembly.

2. Disconnect the electrical connections from the heater electrical panel to the burner at the burner.

3. Remove the nuts securing the burner to the heat exchanger and remove the burner.

4. Remove the fan/limit thermostat as described in 7.5.4 and then remove the inner panel of the heater to expose the heat exchanger clean out panel. Remove the nuts securing the panel and remove the panel.

5. Remove the nuts securing the heat exchanger baffles retention strip and remove strip. Withdraw the baffles.

6. Brush through heat exchanger tubes and remove loose material using a vacuum cleaner. Remove any loose material from the base of the combustion chamber, working through the burner port.

7. Reassemble all components in reverse order. Inspect all gaskets and replace if necessary.

7.4 Fan Assembly

1. Remove the lower panels of the heater to gain access to the fan section.

2. Inspect the fan blades to see that they are not damaged and that there is no excessive build up of deposits that could give rise to an imbalance. If necessary clean the fan blades using a stiff brush and vacuum cleaner.

7.5 Replacement of Faulty Components

7.5.1. Burner Components

1. Refer to the burner supplement supplied with the heater.

7.5.2 Gas Controls Assembly

7.5.2.1 CP-G 100, 150

7.5.2.1.1 Gas Valve Coil.

1. To fit a new valve operating coil remove the electrical supply plug, release the securing nut on top of the valve stem and remove the nut and washer. Lift of the faulty coil and fit the new coil in reverse order.

7.5.2.1.2 Block Valve Assembly.

1. Remove the electrical supply plug.
2. Release the unions on the connections at each end of the assembly and remove complete assembly. Fit new assembly in reverse order ensuring the valve assembly is correctly orientated for the direction of gas flow.

7.5.2.2 CP-G 200, 300

7.5.2.2.1 Block Valve Assembly.

1. Release the union on the gas service valve
2. Remove the electrical connections to the valve assembly.
3. Release the socket head cap screws securing the connection flanges to the main gas block valve and remove the block. Fit new assembly in reverse order ensuring the valve assembly is correctly orientated for the direction of gas flow.

7.5.2.3 CP-G 400 - 2000

1. Release the union on the gas service valve
2. Remove the electrical connections to the valve assembly.
3. Release the unions on the connections at each end of the start gas block valve assembly and remove complete assembly.
4. Release the socket head cap screws securing the connection flanges to the main gas block valve and remove the block. Fit new assembly in reverse order ensuring the valve assembly is correctly orientated for the direction of gas flow.

7.4.3 Main Air Fan and Motor

Note: On 3ph heaters ensure that the fan direction of rotation corresponds with the direction of rotation arrow on the fan guard or case. If necessary reverse the direction of rotation by interchanging any two of the motor live leads at the terminal strip in the electrical panel.

Should it be necessary to remove one or more of the fans for cleaning proceed as follows.

7.4.3.1. CP-G 100 - CP-G 400

Note: These heaters are fitted with direct drive fan units.

1. Disconnect the fan motor electrical leads from the terminal strip (*Refer to Wiring Diagram supplied with the heater*)
2. Remove the two screws, one on each side of the fan mounting flange, the secure the fan to the fan shroud.
3. Withdraw the fan from the slide rails.
4. Reassemble in reverse order.

7.4.3.2. CP-G 500 - CP-G 1250

Note: These units are fitted with belt driven main air fans.

1. Release the motor mounting plate securing screws and then remove the belt tension by turning the tension adjustment screw anticlockwise. Remove the fan belts.
2. Remove the screws securing the fan mounting feet to the heater framework and remove the fan. It may be necessary to reorientate the fan within the fan compartment and also to release the fan shroud fixings in order to pass the fan through the heater frame. On units with twin or triple fan sets on a common fan shaft it will be necessary to first remove the fan shaft.

7.4.4 Fan and Limit Thermostats

7.4.4.1 CP-G 100 - CP-G 700 - Fan / Limit Thermostat - Honeywell L4064N

1. Release the single screw securing the fan and limit thermostat cover and remove cover by pulling forward.
2. Release wiring from clamp terminals by pushing a small screwdriver into the clamp release holes adjacent to the clamps.
3. Remove the 2 screws securing the thermostat to the heater panel and withdraw thermostat.
4. Reassemble new unit in reverse order referring to the heater wiring diagram to ensure correct wiring location.

Important: As supplied by the Manufacturer this fan/limit thermostat is fitted with a brass jumper between the bottom fan terminal and the bottom limit terminal (situated in the slot between the two terminals). This **MUST** be removed, by breaking the link off using a pair of thin nose pliers, before the replacement thermostat is installed.

5. Ensure that the fan and limit settings are as follows:-

Fan ON	50°C	
Fan OFF	30°C	
Limit	CP-G 100 - 150	90°C
	CP-G 200	110°C
	CP-G 300 - 700	100°C

Fig 4 White Rodgers 5F464

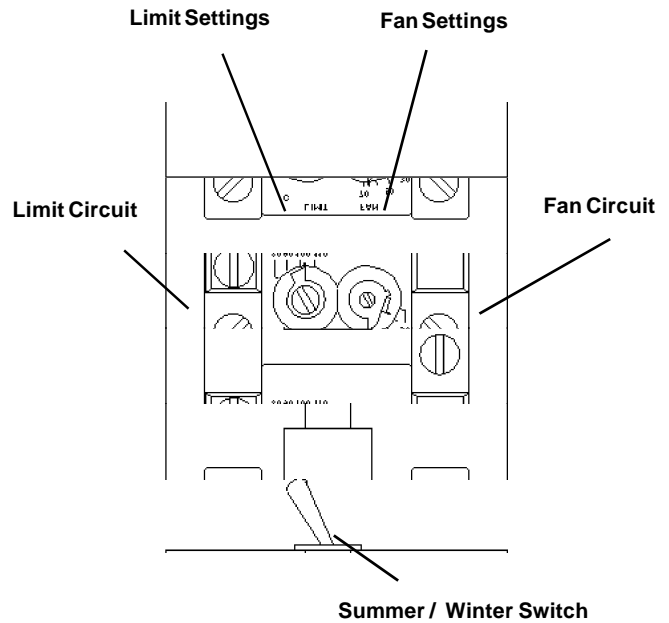

7.5.4.3 CP-G 800 - CP-G 1250 - High Limit Thermostat - Landis & Gyr RAK 21.4/2926.

1. Release the two screws securing the limit thermostat housing cover and remove cover by pulling forward.
2. Release the thermostat from the front cover, two screws
3. Pull off wiring connectors at the rear of the thermostat.
4. Remove the head base or a top side panel from the heater to gain access to the heat exchanger and release the thermostat sensing phial from its holder on top of the heat exchanger and withdraw thermostat and phial.
5. Reassemble new unit in reverse order referring to the heater wiring diagram to ensure correct wiring location.
6. Ensure that the setting is as follows:-
Limit 100°C

8. Connections to Powrmatic External Controls

8.1 Powtrol

CP-G Terminals	connect to	Powtrol Terminals
1		1
2		2
8		5
9		6

8.2 Eurotrol

CP-G Terminals	connect to	Eurotrol Terminals
1		CTRL CCT
2		CTRL CCT
8		FAN CCT
9		FAN CCT

Fig 3 Honeywell L4064N

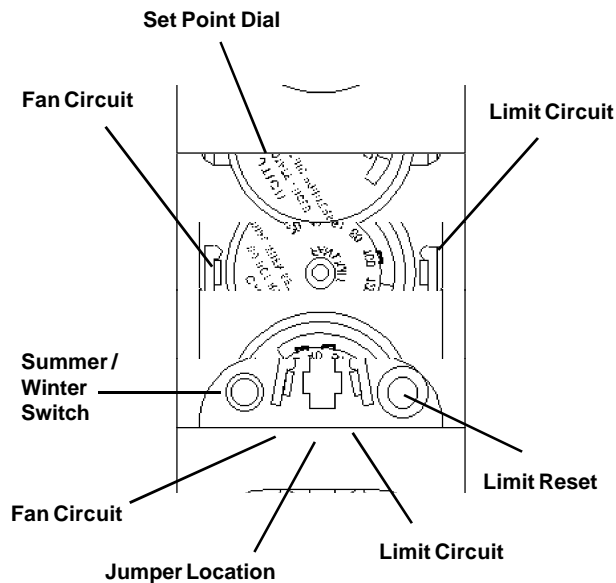

7.5.4.2 CP-G 800 - CP-G 1250 - Fan / Limit Thermostat - White Rodgers 5F464.

1. Release the single screw securing the fan and limit thermostat cover and remove cover by pulling forward.
2. Release wiring from screw terminals.
3. Remove the head base or a top side panel from the heater to gain access to the heat exchanger and release the thermostat sensing phial from its holder on top of the heat exchanger.
3. Remove the 2 screws securing the thermostat to the heater panel and withdraw thermostat and phial.
4. Reassemble new unit in reverse order referring to the heater wiring diagram to ensure correct wiring location.
5. Ensure that the fan and limit settings are as follows:-

Fan ON	50°C
Fan OFF	30°C
Limit	100°C

9. Fault Finding

Refer also to the burner supplement supplied with the heater

Fault	Cause	Action
Main burner will not light	Electrical Gas	1. Check electrical supply is ON. 2. Check controls are ON or calling for heat. 1. Check gas supply is ON.
Main burner lights, but goes out before main fan comes on.	Electrical	1. Unit goes out on high limit - a. Check fan thermostat setting - <i>See Section 7.6.5.</i> b. Faulty fan thermostat - change c. Check limit thermostat setting - <i>See Section 7.6.5.</i> d. Faulty limit thermostat - change. e. Faulty fan assembly - change. f. (Ducted Units Only) -fan motor out on thermal overload. - Check running amps. <i>See table 4.- check duct resistance See Table 5.</i>
Main fan runs continuously	Electrical	1. Summer/Winter switch set to Summer. 2. Fan thermostat set too low - check setting <i>See Section 7.6.5</i> 3. Faulty fan thermostat - change
Main fan fails to run	Electrical	1. Fan motor or capacitor failed - replace. 2. Fan thermostat faulty - replace. 3. Fan contactor failed - replace (3ph units)

10. Short List of Parts

Refer also to the burner supplement supplied with the heater.
Refer to Powrmatic Ltd for the details of any parts not listed here.

ITEM	APPLICATION	PART NUMBER
Johnson Controls GM-7742-3503 - ½"BSP.	100,150, 400 - 1250	141379957
Johnson Controls GM-2540-2000 - ¾"BSP.	200 - 600	141379954
Johnson Controls GM-2040-2000 - 1"BSP.	700 - 800	141379955
Johnson Controls GM-4540-3000 - 1½"BSP.	1000 - 1250	141379967
Thermostat - Fan / Limit Honeywell L4064N	100 - 700	143000303
Thermostat - Fan / Limit White Rogers 5F46-4	800 - 1250	143000331
Thermostat - Limit Landis & Gyr RAK 21.4/2926	800 - 1250	142403597
Contactors - Danfoss CI 9	All	143000608
Overload - Danfoss TI 16 (0.6 - 0.92A)	100 (3ph)	143056103
Overload - Danfoss TI 16 (1.2 - 1.9A)	150 (3ph), 200 (3ph)	143000861
Overload - Danfoss TI 16 (2.7 - 4.2A)	300 (3ph), 400	143000706
Overload - Danfoss TI 16 (4.0 - 6.0A)	500 - 800	143000707
Overload - Danfoss TI 16 (8.0 - 12.0A)	1000	143000770
Overload - Danfoss TI 16 (11.0 - 16.0A)	1250	143000850
Y - Δ Starter - Danfoss SDI 12 047 L1280-38	1000LHP, 1250	143070226
Heat Exchanger Cleanout Door Gasket.	All	170246006
Pressure Relief Door Gasket - 114mm dia.	All	142202110
Pressure Relief Door Gasket - 95mm dia. Heat.	All	142202257
Pressure Relief Door Gasket - 166mmx 166mm.	All	142202310
Burner Gasket - Nu-Way PCGS 2/3/5.	100 - 500	144704004
Burner Gasket - Nu-Way PCGS 8.	600	144704015
Burner Gasket - Nu-Way PCGS 13/25	700 - 1250	144704024
Burner Gasket - Riello GS5.	100	141937080
Burner Gasket - Riello GS10.	150 - 300	141930806
Burner Gasket - Riello GS20.	400 - 600	142931252
Burner Gasket - Riello Gas 3	700 - 1000	142931240
Burner Gasket - Riello Gas 5	1250	142931245

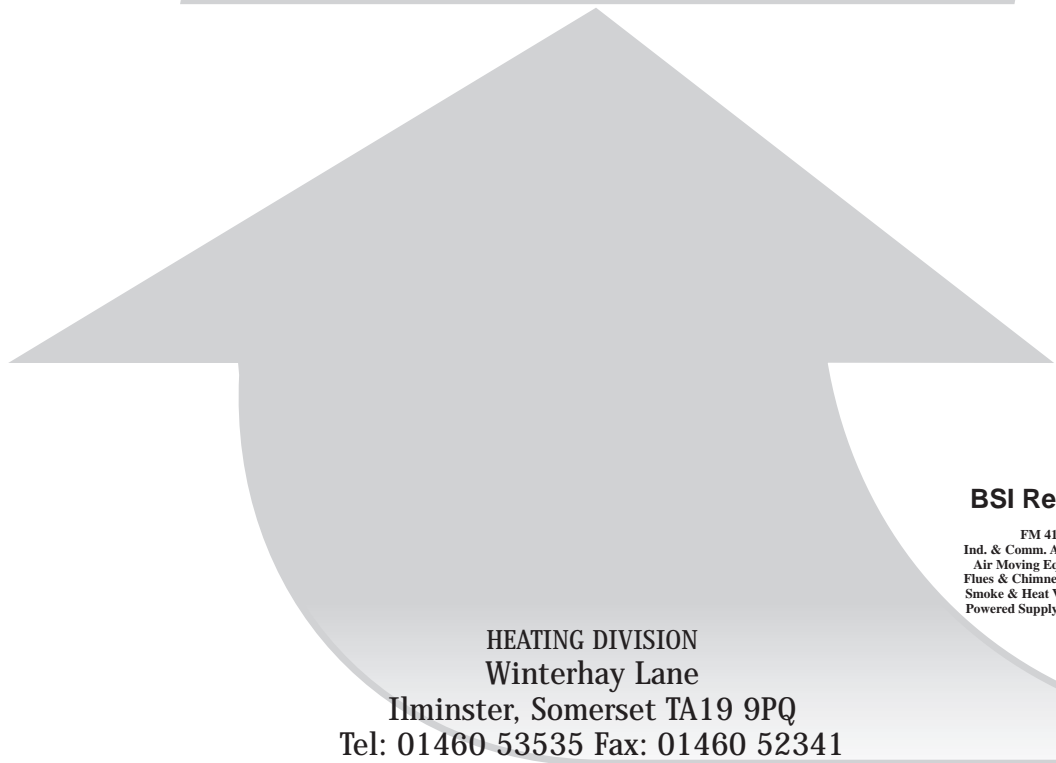

BSI Registered Firm

FM 414
Ind. & Comm. Air Heaters;
Air Moving Equipment;
Flues & Chimneys; Natural
Smoke & Heat Ventilators;
Powered Supply & Extract



HEATING DIVISION
Winterhay Lane
Ilminster, Somerset TA19 9PQ
Tel: 01460 53535 Fax: 01460 52341