

GAS FIRED AIR HEATERS TYPE EUROPAK RPVE/RPVJ 2000

Centrifugal Blown, Forced Convection Appliances with
Automatic Ignition and Flue-less Fanned combustion circuit for outdoor use:

Installation, Commissioning, Servicing & User Instructions

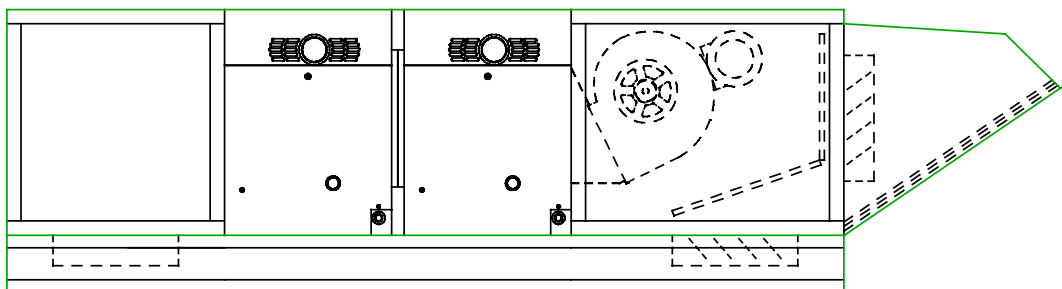

These appliances meet the following EC Directives:

Dir. CE 90/396/EEC:	GAD
Dir. CE 89/336/EEC:	EMC
Dir. CE 89/392/EEC:	MD
Dir. CE 73/23 /EEC:	LVD

PLEASE READ THIS DOCUMENT CAREFULLY BEFORE COMMENCING THE INSTALLATION AND LEAVE IT WITH
THE USER OR ATTACHED TO THE GAS SERVICE METER AFTER INSTALLATION

INDEX

SECTION	Page
1. General	2
2. Technical data	3
3. Installing	10
4. Gas connection	14
5. Electrical connection	15
6. Commissioning, lighting and operation	16
7. Two stage burner setting	19
8. Maintenance	20
9. Fault finding	24
10. Spare parts listing	25
11. Gas conversion	26
12. Health & Safety Statement	27
13. User instructions	28

NOTE: If optional equipment was ordered and supplied with this heater, please refer to additional instructions for option(s)

These instructions are based upon document O108T2RPG BEN RPVE & RPVJ 2000 Air Heaters for Outdoor use

SECTION 1 GENERAL

- 1.1 Before installation, check that the appliance as described on the packaging label is in accordance with the correct type and model as specified on the data plate and complies with your customer order.
- 1.2 After unpacking the appliance, leave it fastened to any transit packing until just before siting.
- 1.3 Please read this document before commencing installation.
- 1.4 These instructions are only valid for the country of use as indicated on the appliance i.e. GB - IE. If these symbols are not shown, it is necessary to obtain appropriate technical instructions which will provide information concerning the necessary modification of the appliance for the conditions of use in the country concerned. Such instructions may be obtained upon request from your supplier.
- 1.5 Check that the local distribution, conditions of electricity supply, type of gas and pressure of the appliance are compatible.
- 1.6 When installed in Great Britain the total installation must comply with the requirements and recommendations of British Standard BS 6230 1991. " Installation of Gas Fired Forced Convection Air Heaters for Commercial and Industrial Space Heating". The installation must also be in accordance with the relevant requirements of "The Gas Safety (Installation and use Regulations) and (Amendment regulations 1990)" and The "Building" and "Electrical Regulations" (in GB the IEE Regulations). The requirements of the "Local Building Standards office", the premises "Insurance" undertaking and the "Fire Office" must also be observed.
- 1.7 Unauthorised modification of this appliance or departure from use in the manner for which it was intended by the manufacturer or installed in a manner contrary to these instructions, may constitute a hazard and jeopardize all warranties. Deviations should only be carried out after formal consent has been obtained from the manufacturer.
- 1.8 Ensure the environment in which the air heater will be installed will not create a hazard i.e. where excessive (volatile) dust, flammable or corrosive substances and/or vapours and combustible materials may be present.
- 1.9 This appliance has been tested and set according to the data plate before leaving the factory.
- 1.10 **IMPORTANT**
Care must be taken when installing air heaters in outdoor locations to ensure that unauthorised access to the building cannot be gained via the appliance or its duct-work system.

SECTION 2 TECHNICAL DATA

Figure 1 Appliance recognition

CONFIGURATIONS	..10	..11	..20	..22
<div style="display: flex; align-items: center; margin-bottom: 5px;"> <div style="width: 15px; height: 15px; background-color: gray; margin-right: 5px;"></div> Gas heating module </div> <div style="display: flex; align-items: center;"> <div style="width: 15px; height: 15px; border: 1px solid black; margin-right: 5px;"></div> Air handling module </div>	<div style="width: 15px; height: 15px; background-color: gray; margin-bottom: 5px;"></div> <div style="width: 15px; height: 15px; border: 1px solid black;"></div>	<div style="width: 15px; height: 15px; background-color: gray; margin-bottom: 5px;"></div> <div style="width: 15px; height: 15px; background-color: gray; margin-bottom: 5px;"></div> <div style="width: 15px; height: 15px; border: 1px solid black;"></div>	<div style="width: 15px; height: 15px; background-color: gray; margin-bottom: 5px;"></div> <div style="width: 15px; height: 15px; background-color: gray; margin-bottom: 5px;"></div> <div style="width: 15px; height: 15px; border: 1px solid black; margin-bottom: 5px;"></div> <div style="width: 15px; height: 15px; border: 1px solid black;"></div>	<div style="width: 15px; height: 15px; background-color: gray; margin-bottom: 5px;"></div> <div style="width: 15px; height: 15px; background-color: gray; margin-bottom: 5px;"></div> <div style="width: 15px; height: 15px; background-color: gray; margin-bottom: 5px;"></div> <div style="width: 15px; height: 15px; background-color: gray; margin-bottom: 5px;"></div> <div style="width: 15px; height: 15px; border: 1px solid black; margin-bottom: 5px;"></div> <div style="width: 15px; height: 15px; border: 1px solid black;"></div>

Table 1. Appliance Data: Standard Efficiency Models

Standard version EUROPAK RPV 2095..			.. 10	.. 20	.. 11	.. 22
Low NO _x version EUROPAK RPV 2595..						
Gas category			II _{2H3+}			
Appliance type			Gas Fired Air Heaters for OUTDOOR use only			
Heat input GCV (H _s)	kW		115,40	230,80	461,60	
Heat input NCV (H _i)	kW		104,00	208,00	416,00	
Nominal heat output @ 100% rate	kW		91,00	182,00	364,00	
Nominal heat output @ 75% rate	kW		42,90	133,90	85,80	267,80
Nominal heat output @ 50% rate	kW		42,90	91,00	85,80	182,00
Nominal heat output @ 25% rate	kW		42,90	42,90	85,80	85,80
Number of gas jets			16	2 X 16		4 X 16
Jet size	Natural gas	Ø mm	2,4			
	Propane/Butane	Ø mm	1,35			
Gas supply pressure ¹	Natural gas G20	mbar	(GB) = 17,5 (IE) = 20,0			
	Propane G31	mbar	37,0			
	Butane G30	mbar	28,0			
Burner pressure	Natural gas ² G20	mbar	8,50			
Gas consumption	Natural gas ³ G20	m ³ /h	11,01	22,02	44,04	
	Propane gas G31	kg/h	8,24	16,49	32,97	
	Butane gas G30	kg/h	8,42	16,85	33,69	
Gas connection size		Rc	¾	1¼		1¼
Air volumes ⁴	minimum	m ³ /h	8 500	10 000	17 000	20 000
	maximum	m ³ /h	17 000	17 000	34 000	34 000
Electrical service Protection to class IP45			3 ~ 400/415 V 3 N ~ 50 Hz			
Electrical rating (controls circuit) ⁵	kW		0,15	0,30		0,60

Notes to table 1

- 1 Maximum gas pressure to inlet of appliance = 50 mbar
- 2 All casing panels closed service door open
- 3 Natural gas G20 Calorific value 10,48 kWh/m³ @ 15 °C 1013 mbar
- 4 Isothermic @ 15 °C
- 5 Burner Controls circuit only + motor current. During start-up period ± 30 seconds current rating is increased by 130 W per heater module, not included in the above ratings

Table 2 Appliance Data: Higher Efficiency Models

Standard version EUROPAK RPV 2096 .. Low NO _x version EUROPAK RPV 2596 10	.. 20	.. 11	.. 22
Nominal heat output 100%	kW	94,60	189,20		378,40
Nominal heat output 75%	kW		139,30		278,60
Nominal heat output 50%	kW	44,70	94,60	89,40	189,20
Nominal heat output 25%	kW		44,70		89,40
All other data is the same as for the version with standard efficiency					

Table 3. Motor Schedule Size, Rating & Starting mode

Motor rating	kW	0,55	0,74	1,1	1,5	2,2	3,0	4,0	5,5	7,5	11	15
Nominal full load current	± A	1,4	1,8	2,6	2,9	5,2	7,0	8,9	12	16	22	30
Starting mode	Direct on line							λ/Δ				

Table 4. TABLES OF WEIGHTS, including base frames

EUROPAK MODEL RPV 2000		..10	..20	..11	..22
SECTION N°	DESCRIPTION	MODULE WEIGHT kg			
2.3 or 2.5	Gas fired air heater/s	215		410	
2.4 or 2.6	Gas fired air heater/s		420		810
1.1, 1.3 and 1.4	Blower section	210		350	
1.2	Blower section	190		310	
3.1	Filter section	130		190	
3.2 and 3.3	Filter section	150		240	
4.1	Heat recovery section ¹⁾	160		420	
4.2	Heat recovery section ¹⁾	200		500	
5.1	Air intake or blowing section	120		170	
5.2	Air intake or blowing section	140		220	
6.1	Mix-box section	230		540	
6.2	Mix-box section	310		700	
6.3	Mix-box section	130		340	
7.1	Air intake hood (RPV)	50		90	
Option	Damper unit (each)	20		40	
Option	Servo motor for dampers	7		7	

Note: ¹ excluding heat pipe, add 200 kg for -10 or -20 or 400 kg for -11 or -22

Table 5. Motor weights including mountings

Motor rating	kW	0,55	0,74	1,1	1,5	2,2	4,0	5,5	7,5	11,0	15,0
Weight	kg	10	10	18	20	24	50	80	120	160	185

Figure 2. DIMENSIONS OF BLOWER SECTIONS - SUPPLY AIR CABINETS 1.1 & 1.4

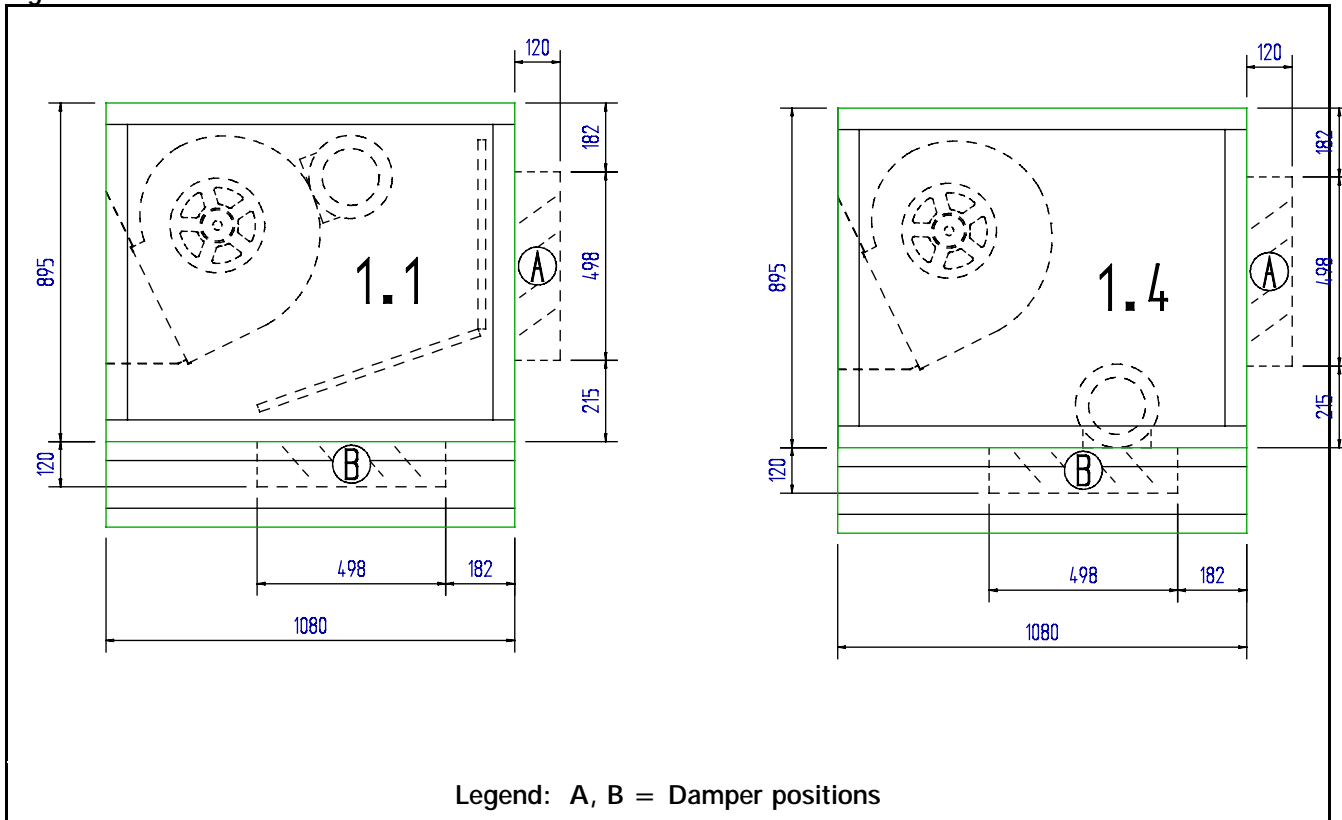

Figure 3. DIMENSIONS BLOWER SECTIONS - EXHAUST AIR CABINETS 1.2 & 1.3

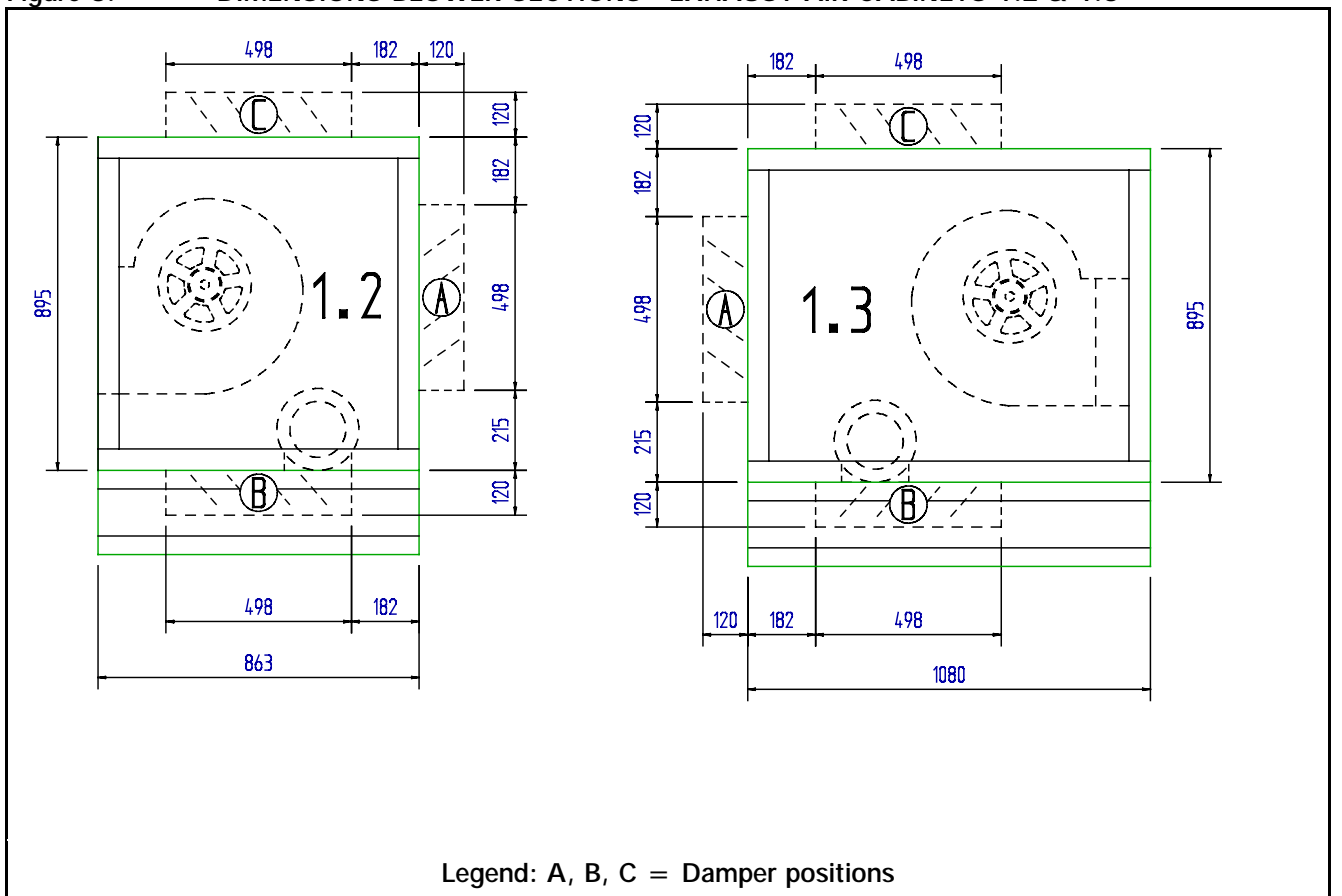

Figure 4. DIMENSIONS GAS FIRED HEATING SECTIONS - 2.5 & 2.6

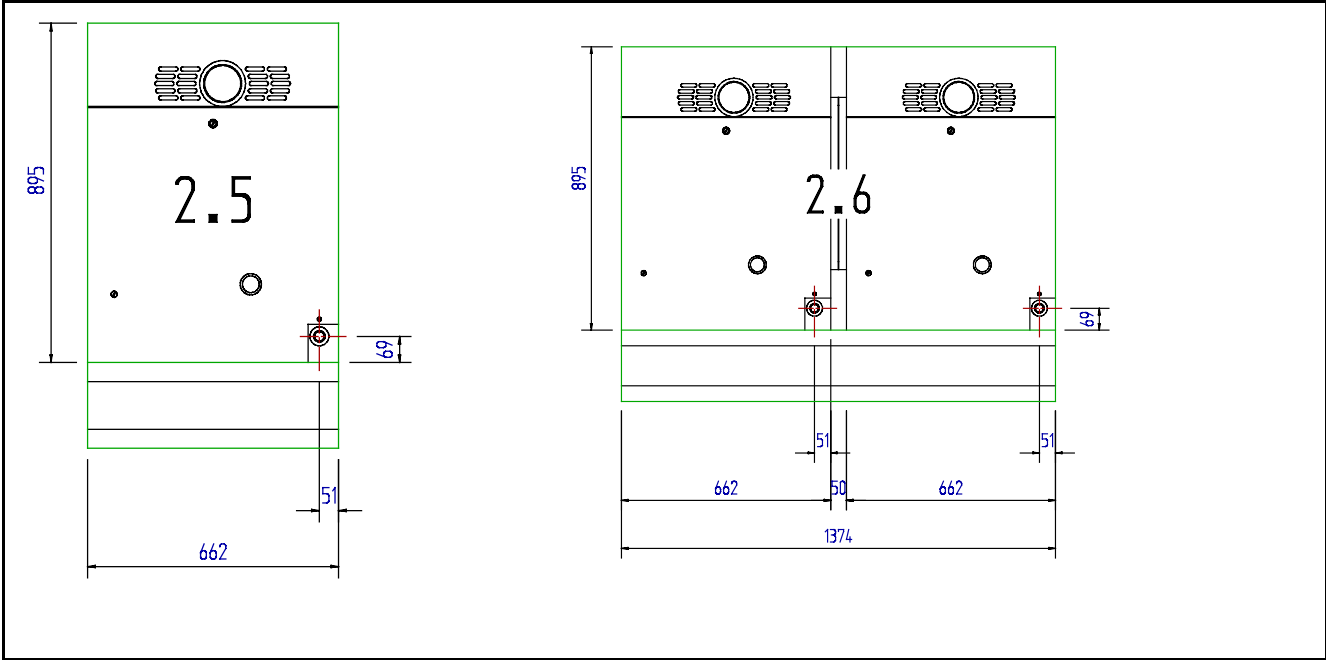

Figure 5. DIMENSIONS FILTER SECTIONS - CABINETS 3.1, 3.2 & 3.3

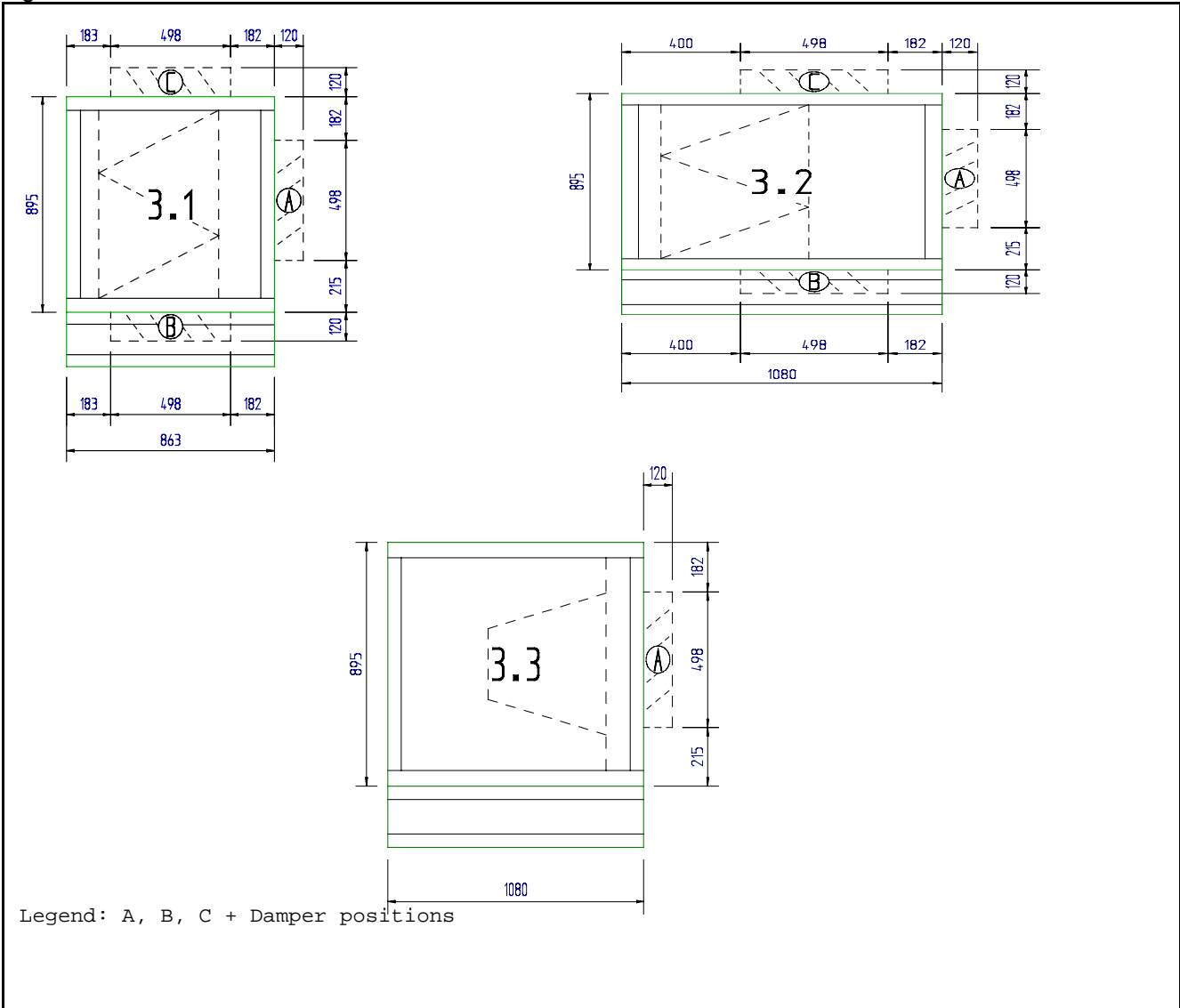

Figure 6. DIMENSIONS HEAT RECOVERY SECTIONS - CABINET 4.2

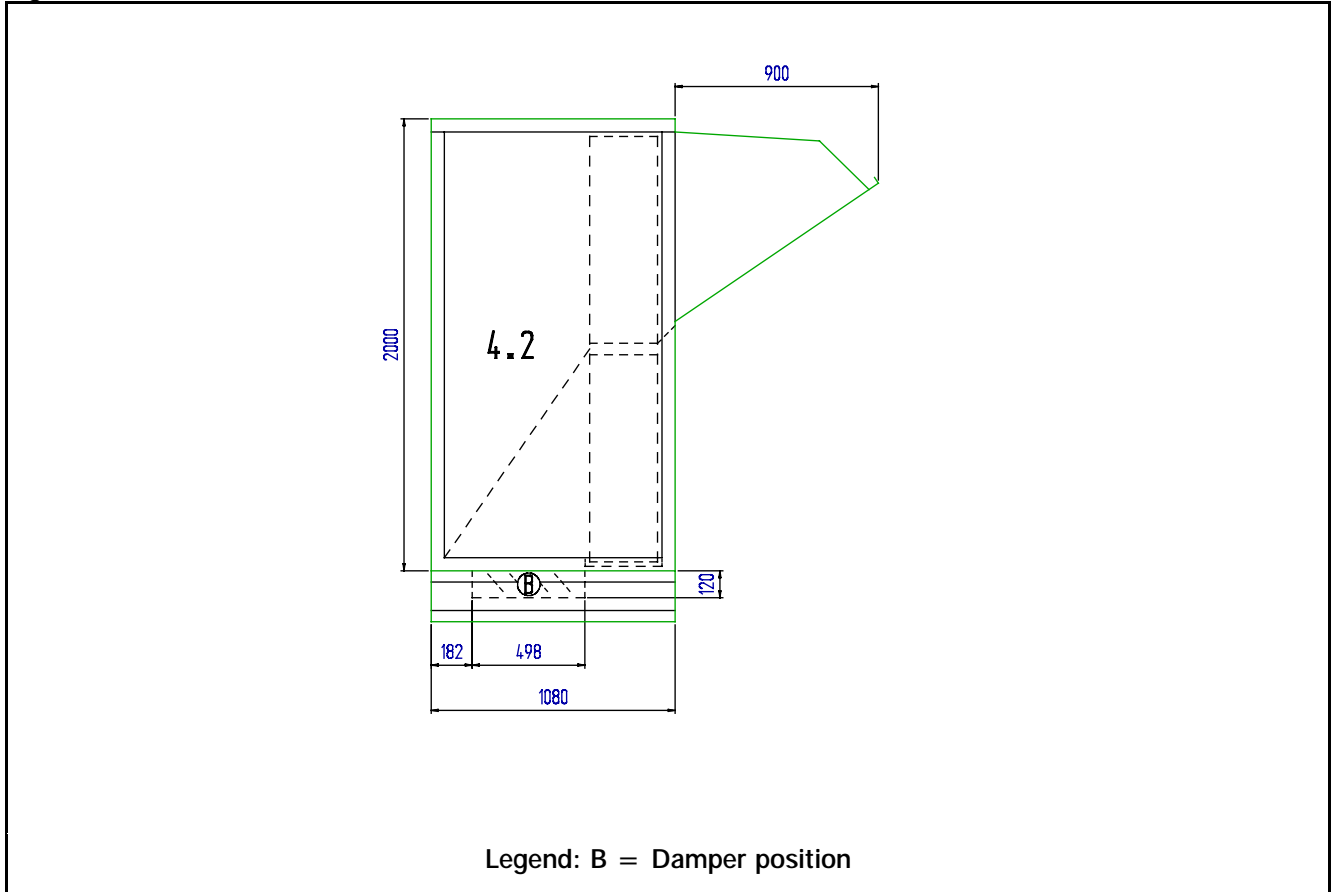

Figure 7. DIMENSIONS INTAKE OR BLOWING SECTIONS - CABINETS 5.1 & 5.2

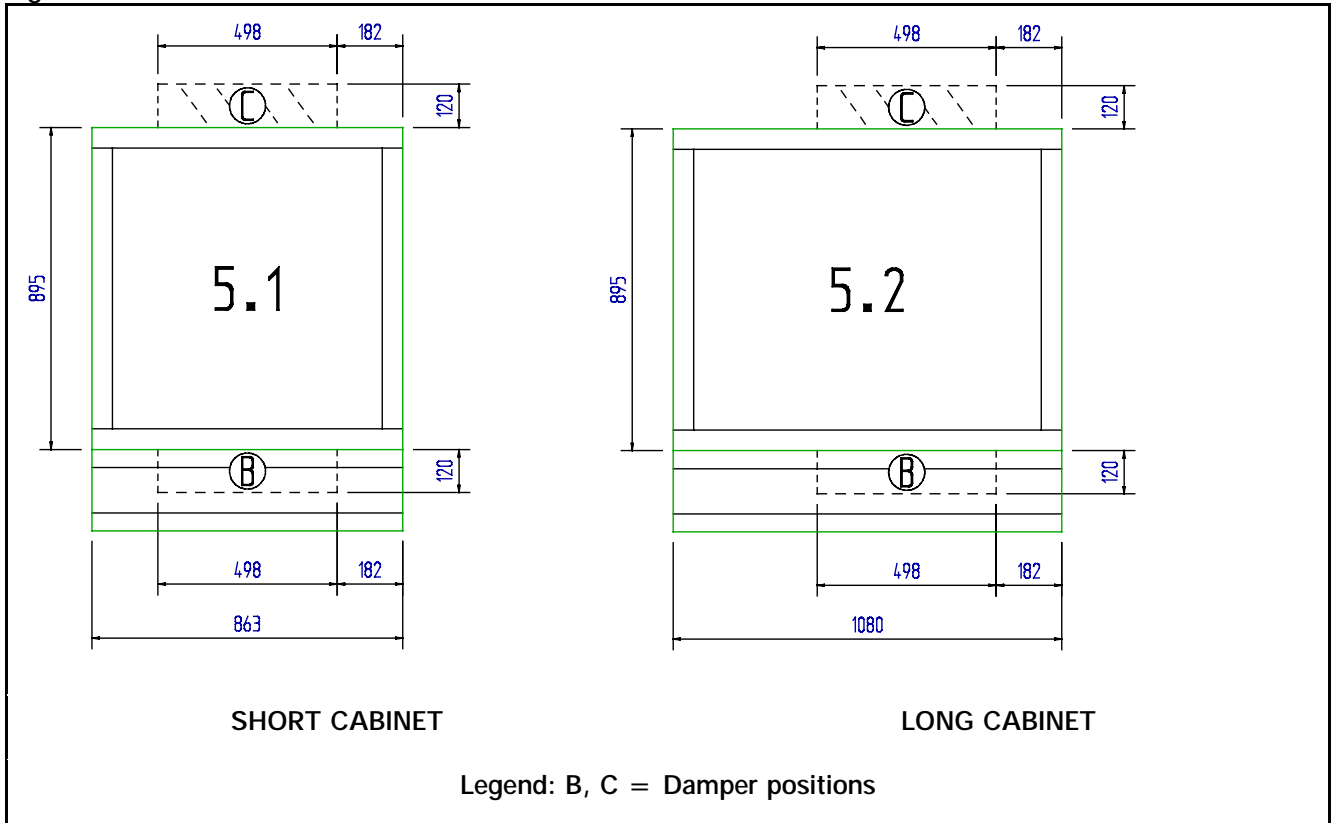

Figure 8. DIMENSIONS FOR MIX BOX SECTION - CABINET 6.2

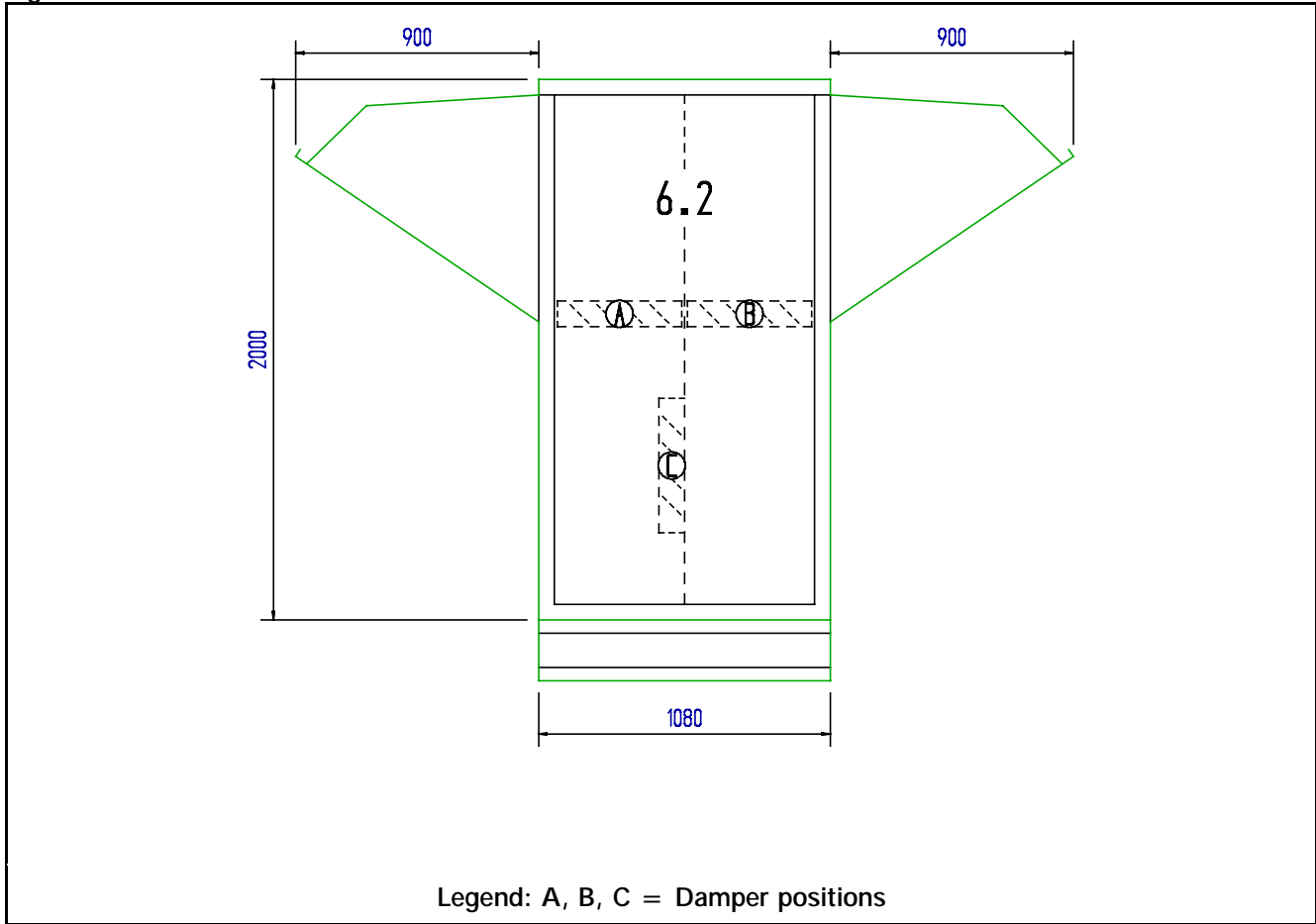

Figure 9. MIX BOX SECTION - CABINET 6.3

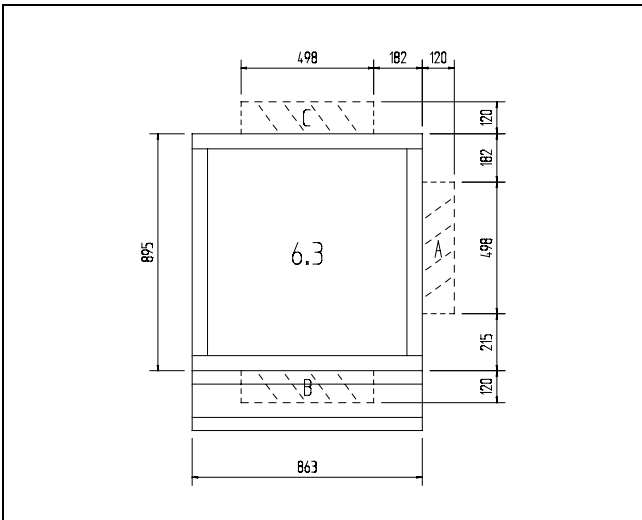
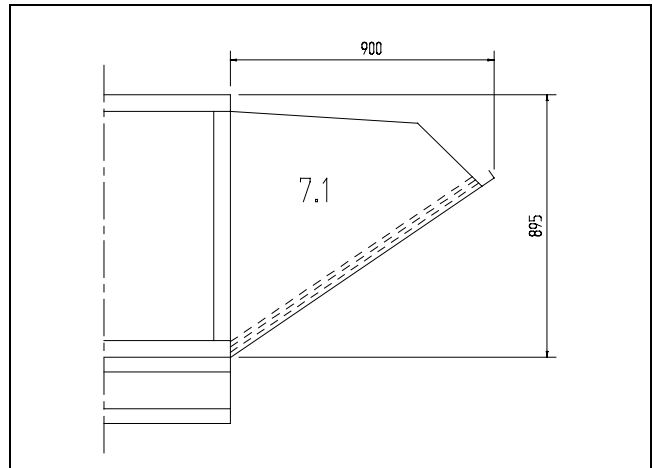

Figure 10. WEATHER PROOF INTAKE HOOD SECTION - CABINET 7.1



Legend: A, B, C = Damper positions

Figure 11

DIMENSIONAL PLANS OF ASSEMBLIES

EUROPAK RPV 2.95/2.96 -10, -20, -11 & -22

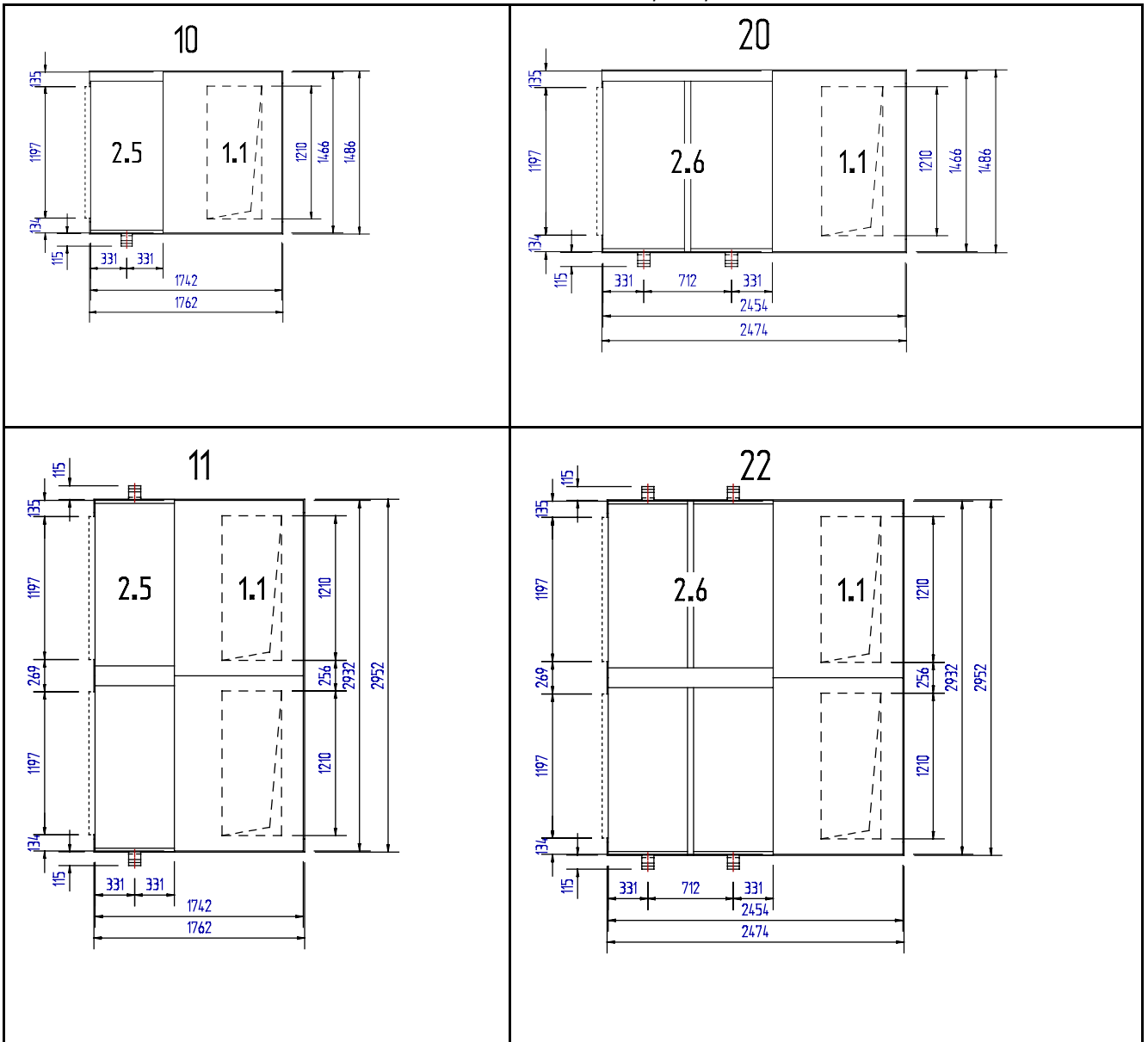

ROOF CURBS

Reznor EUROPAK Air Heaters are supplied assembled onto a base frame optional roof curbs are available in 2 heights of 300 and 500 mm dimensions are shown in figure 12 below.

It is recommended that the inside of a roof curb is insulated to prevent condensation occurring.

NOTE: All fresh air intakes of outdoor appliances must be at least 500 mm above deck level to their lowest point.

Figure 12. ROOF CURB DIMENSIONS AND DETAILS

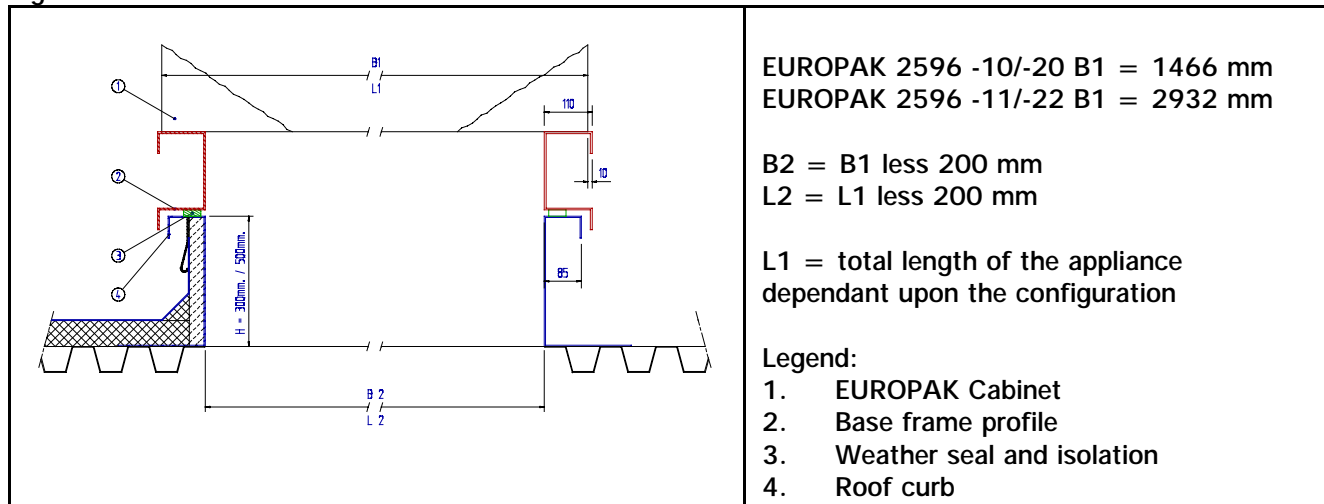

Table 6. ROOF CURB WEIGHTS

EUROPAK RPV 2000...		-10 & -20		-11 & -22	
Curb height overall	mm	300	500	300	500
Nominal weight X ¹	kg	68	92	119	177
Weight per metre Y ¹	kg	30	40	30	40

NOTES to TABLE 6:

1. ¹Total weight = X + Y where L = total length of the appliance in metres.
2. The RPV may be installed directly onto its base frame of the type not for use with a roof curb without a roof curb included in the installation, i.e. when mounted on a support frame work.

SECTION 3 INSTALLING

- 3.1 When installing outdoor appliances ensure that all of the outdoor elements of the installation will not jeopardize the integrity of the premises security.
- 3.2 Ensure that the structural elements which will be used to support the appliance are adequate to carry the weight of the appliance and its ancillary components i.e. the duct-work system.
- 3.3 A distance of 500 mm must be maintained between any deck on which the appliance is installed and any air inlet to the appliance.
- 3.4 The location where the air heater is to be installed, must provide sufficient space around the air heater for servicing and to allow the flue products to escape freely. A minimum distance of 1500 mm must be maintained on the controls side of the appliance, on PRPV 2011/22 and PRPV 2511/22 models this applies to both sides of the appliance.
- 3.5 When installed at ground level the entire installation should be protected by a fence to guard against damage and to protect the public from possible injury.
- 3.6 Ensure that the air heater is installed in a level plain and that the surface onto which it is installed is vibration free.
- 3.7 The air heater must be fastened securely to any base mount frame work. Roof curbs are manufactured from galvanized mild steel and should be fixed prior to siting the appliance.

- 3.8 It is necessary to provide weatherproof seals between the appliance and the structural elements of the building.
- 3.9 Care should be taken when designing ducting systems especially with regard to the selection of fittings which will be installed adjacent to the appliance, abrupt elbows fitted directly on to the appliance can cause turbulence and create uneven air flows across the heat exchanger, resulting in hot spots and nuisance shut down of the burner due to regional overheating in the vicinity of the over heat protection devices. Unnecessary pressure loss and noise generation may also be caused by badly designed duct systems.

3.10 Ducting should be manufactured from materials suitable for the purpose taking into account the integrity of the building security.

3.11 When siting the appliance and unloading, extreme care must be exercised to ensure that the slings etc. employed do not damage the casing. The weatherproofing will become unsealed should any damage be sustained. Sling spreaders must be used to provide clearance between the appliance and the slings. Figure 14 shows the location of spreaders and the detachable slinging points provided for this purpose.

Figure 13 RECOMMENDED METHOD OF DUCT CONNECTION

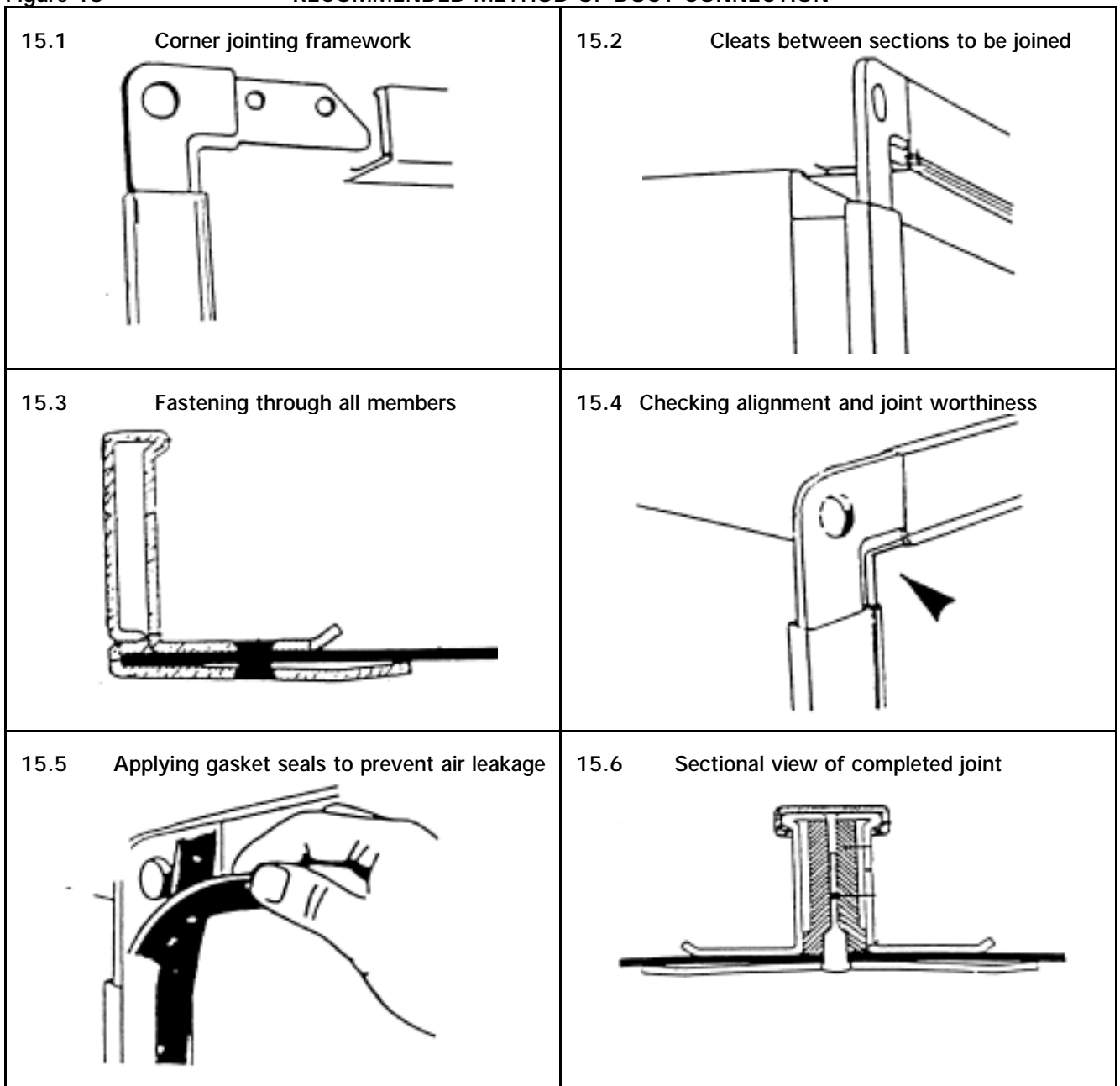

Figure 14.

SLINGING THE APPLIANCE FOR UNLOADING AND SITING

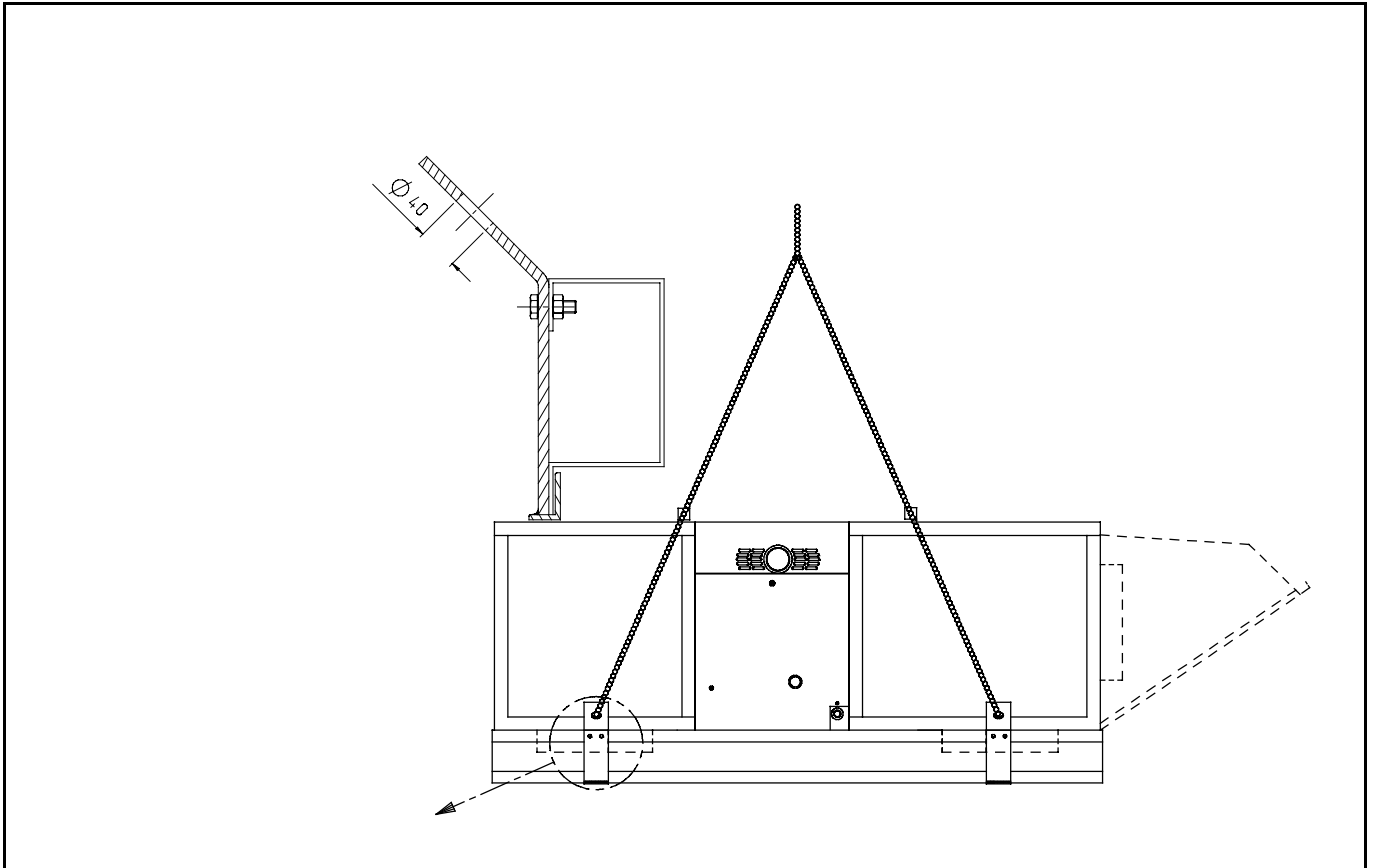

Figure 15. PLANS OF APPLIANCE TYPES SHOWING DIRECTION OF AIR FLOW & CENTRE OF GRAVITY

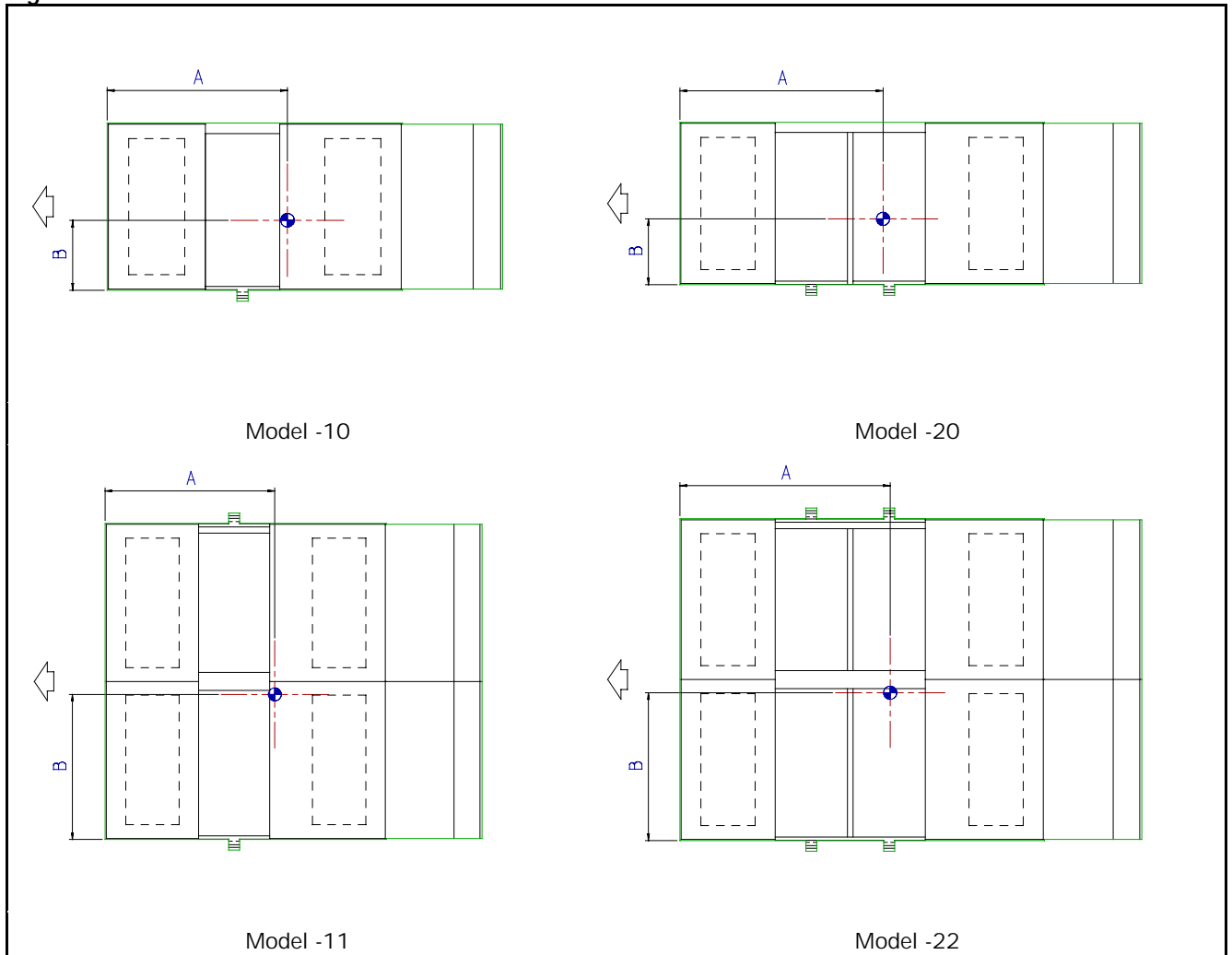

Table 7. APPROXIMATE CENTRES OF GRAVITY FOR STANDARD CONFIGURATIONS Re. FIGURE 15.

EUROPAK RPV..	2000-10		2000-20		2000-11		2000-22	
	A	B	A	B	A	B	A	B
Gravity point with standard motor = kW								
0,55 - 0,74	1375	710	1700	720	1350	1450	1690	1460
1,1	1400	705	1720	715	1380	1440	1700	1455
1,5	1425	700	1750	710	1405	1435	1720	1450
2,2	1450	690	1770	700	1430	1420	1740	1450
3,0	1525	660	1800	670	1495	1400	1730	1420
4,0	1560	670	1810	680	1520	1400	1740	1420
5,5	1610	660	1820	670	1560	1390	1770	1410
7,5	1650	660	1830	670	1590	1390	1790	1410
11,0	1725	640	1855	650	1650	1380	1750	1400
15,0	1750	630	1870	640	1670	1370	1810	1390

SECTION 4 GAS CONNECTION

- 4.1 Connection to a gas service may only be carried out by appropriately qualified persons. The gas installation must comply with the rules in force using materials appropriate for gas installations.

4.2 Check that the gas category is in accordance with the data described on the air heater.

4.3 An adequate gas supply sized to provide the dynamic pressure for the volume required for the air heater/s is essential to maintain the nominal heat input. Other gas fired plant using the same gas service must also be taken into account.
- 4.4 A 90° action, positive stopped gas service tap must be fitted adjacent to the appliance, fitted in a manner to facilitate appliance burner removal for servicing purposes, see figures 16 and 17.

4.5 Ensure that the gas service includes a filter and has been tested and purged in accordance with prescribed practice prior to commissioning and taking the appliance into service.

4.6 As a rule, gas service pipes should not be routed through air ducts. Should it be necessary to do so then pipe work joints must not be made within the air duct.

FIGURE 16. DETAIL OF GAS CONNECTION EUROPAK RPV 2000-10 & 2000-20

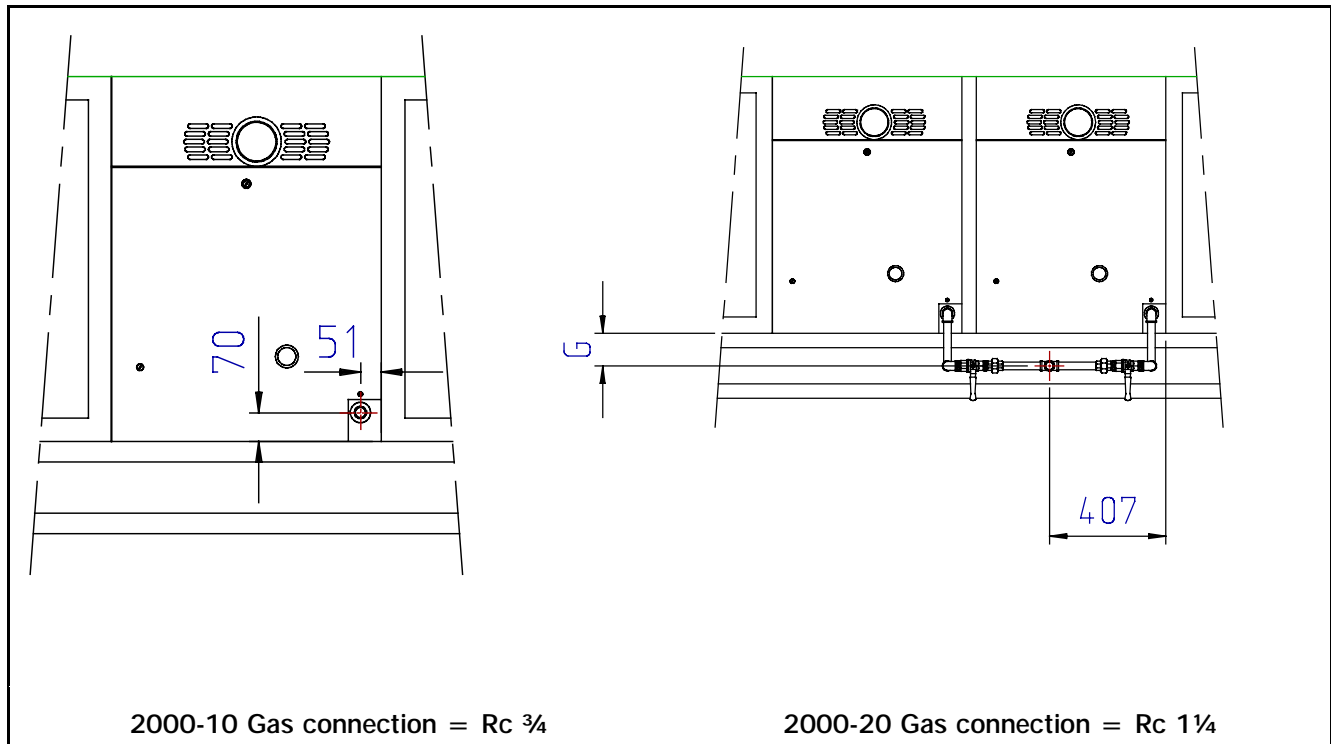

Table 8. DIMENSIONS REFERENCE FIGURE 16

EUROPAK MODEL NUMBER	Dimension G mm
2000-10 & 2000-20 - With standard base frame	80
2000-10 & 2000-20 - With roof curb base frame	115

Figure 17. DETAIL OF GAS CONNECTION EUROPAK RPV 2000-11 & 2000-22

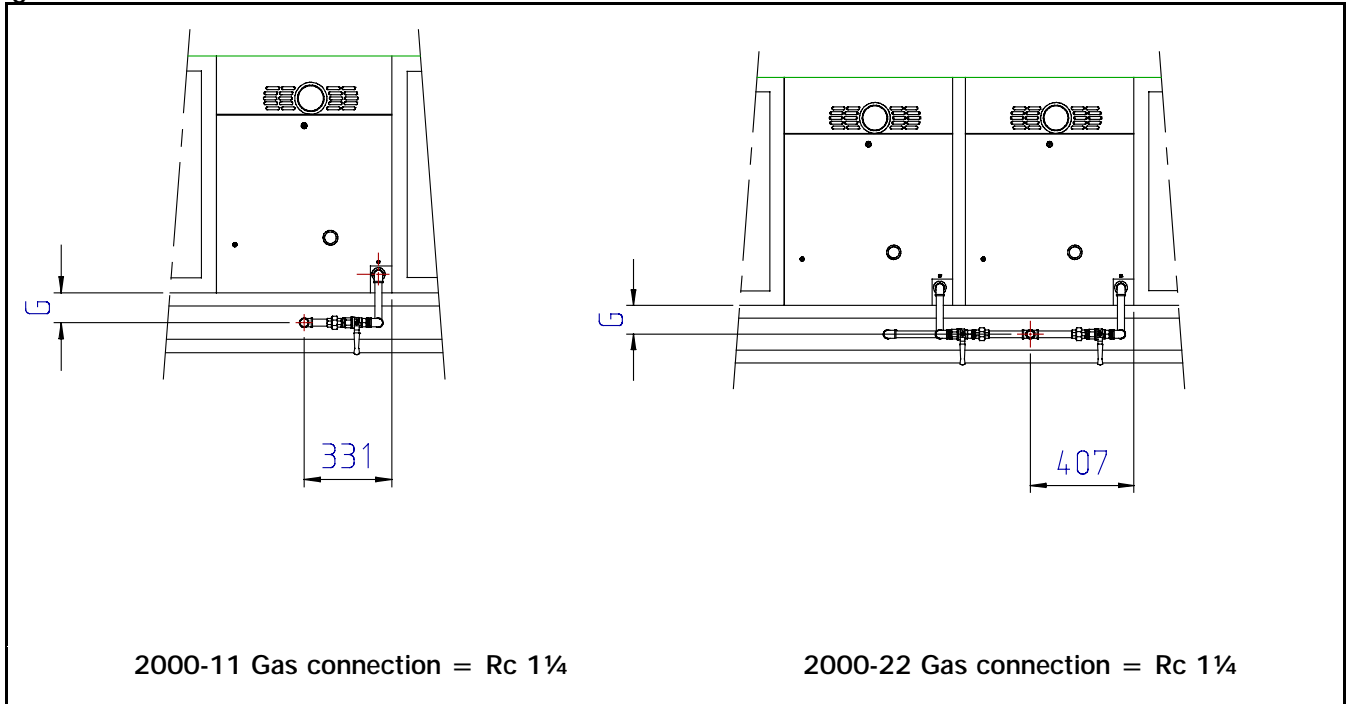

Table 9. DIMENSIONS REFERENCE FIGURE 17

EUROPAK MODEL NUMBER	Dimension G mm
2000-11 & 2000-22 - With standard base frame	80
2000-11 & 2000-22 - With roof curb base frame	115

WARNING: NEVER USE A FLAME TO TEST FOR GAS SOUNDNESS

SECTION 5 ELECTRICAL CONNECTION

- 5.1 The electrical installation may only be carried out by appropriately qualified persons observing the rules in force.
- 5.2 Check the electrical specification is in accordance with the specification on the appliance data plate. A unique appliance wiring diagram is supplied as a separate document attached to this one plus an additional copy attached to the air heater.

NOTE: During the burner ignition cycle the electrical current will exceed the values stated on the appliance data plate by 0,9 kW for a period of 45 seconds. Staged start up of burner modules may be necessary to accommodate this load on the appliance external wiring circuit.
- 5.3 EUROPAK RPV air heaters must be earthed.
- 5.4 Ensure that when planning the controls circuitry, that power will be supplied at all times to the air heater, even when it is control switched in the "HEAT OFF" mode. This is necessary to ensure that the air circulating fan can operate independently of the heating control. Therefore, **NEVER** incorporate automatic controls that electrically isolate the appliance.
- 5.5 A separate lockable isolator for each air heater must be provided adjacent to the appliance and within the sight line of any person working on the appliance. The isolator must have a contact separation of at least 3.0 mm on all poles. The isolator should be of the key operable type to prevent vandalism and to prevent switching by others thus placing anyone working on the appliance at safety risk.
- 5.6 Ancillary controls are required to provide timed heat cycles, room comfort temperature level, frost protection, override air circulation etc. These are not included with the air heater and must be ordered separately.

- 5.7 Dependent on the options fitted there may be a supplementary wiring box fitted within the blower section cabinet.
- 5.8 Three phase appliances without the supplementary wiring box should be connected via the motor starter. The five wires fitted for the purpose of manufacturing testing and left installed must be removed and substituted by the supply line cables. In this case the wiring for the room thermostat and time control must be connected to the DIN rail terminals behind the burner compartment access panel.
- 5.9 If the supplementary wiring box is fitted then all of the wiring connections including the external controls are terminated in the box, whether it be a single or three phase appliance.
- 5.10 **NOTE:** When working on the appliance the electricity to the appliance must never be switched **OFF** before the room thermostat has been switched **OFF**, the gas valve has closed and the air circulation fan has stopped.
- 5.11 All cable and gas service entry points to the appliance must be sealed to prevent ingress of water.
- 5.12 If it is necessary to change the rotation of the blower to match the direction indicated on the blower housing then three phase motors can be altered by switching two phases of the line supply to the motor.
- 5.13 The centrifugal blower/s that are fitted to the EUROPAK RPV appliances are of the forward curved type therefore, the speed setting for the static pressure imposed by the air distribution system will govern the motor loading. All EUROPAK air heaters leave the factory with the drives set for the duty specified on the order. Table 3 provides the motor characteristics for the various sizes within the product range.
- 5.14 Refer to section 6 to learn how to carry out adjustments necessary to alter the fan speed and motor load factors.

NOTE: EUROPAK AIR HEATERS ARE SUPPLIED WITH THE EXTERNAL CONTROL CIRCUITS BRIDGED. THE AIR HEATER/S WILL OPERATE CONTINUOUSLY UNLESS THESE ARE REMOVED AND THE TIME AND TEMPERATURE CONTROLS SUBSTITUTED FOR THEM.

SECTION 6. COMMISSIONING, LIGHTING AND OPERATION

COMMISSIONING

6.1 Normally Reznor EUROPAK air heaters do not require commissioning. Final testing after production ensures that: **If installation has been carried out strictly in accordance with this document**, the appliance is ready to be taken into service.

NOTE: Outdoor commissioning work on EUROPAK RPV appliances should not be undertaken during wet conditions, a second person must be available to provide assistance in the event of an emergency.

- 6.2 Checks to ensure;
- earth continuity
 - resistance to earth
 - phase supply to correct terminals
 - current rating and fuse value
 - correct supply gas pressure
 - correct burner gas pressure
 - satisfactory & smooth ignition

6.3 In addition to the above requirements checks to ensure that the fan performance and motor load factors are correct for the application and in accordance with the appliance data plate.

6.4 Drives general and adjustments

6.4.1 The drive assembly of EUROPAK air heaters is guard protected to class IP45. Adjustment may be necessary to set the fan duty for the static pressure and motor load requirements. It is therefore, necessary to remove the access panels prior to making adjustments. Before commencing work on the fan assembly:

- Set external controls to off or their lowest setting.
- Turn **OFF** the gas supply to the air heater.
- Switch **OFF** the electricity supply to the air heater **after the air circulating fan has stopped**.
- Remove protection panels as necessary and carry out adjustments as appropriate.
- Before placing the appliance back into service or switching the fan on ensure that all protection access panels are replaced and secured.

N.B. Rotational speed checks should be carried out using an infra red tachometer or stroboscope.

A temporary panel is necessary to ensure that reliable readings are taken with the blower cabinet access panel fitted in position.

Be aware that clean and dirty filters will influence readings.

6.4.2 Adjusting the fan speed can be carried out by altering the diameter of the adjustable drive pulley.

- loosen the belt tension device and remove the drive belt.
- refer to figure 18 and note that the outer section of the drive pulley is secured by a hexagon socket grub screw to a flat on the pulley hub, this is positioned by loosening the grub screw sufficiently to enable the pulley to be either opened or closed by turning it on the thread on which it is engaged.

- it should be noted that one complete turn of the pulley half is equal to approximately 8% of the fan speed. Closing the pulley increases the speed and opening decreases the speed.
- after making speed adjustments tension belt in accordance with the dimensions given in figure 18 and check pulley alignment to ensure the belt runs correctly.

N.B. Always ensure that the pulley is tightened onto a flat of the hub before switching on the fan, even when testing a reset condition.

6.4.3 **Caution!**

Opening the pulley too far will cause the belt to touch the bottom of the V groove resulting in greatly reduced belt life and loss of grip.

FIGURE 18. PULLEY & DRIVE BELT ADJUSTMENT

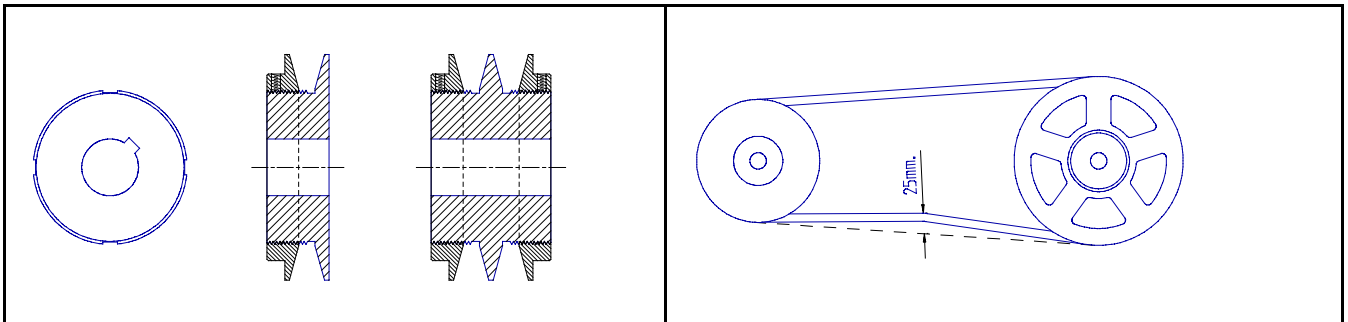

6.4.4 If the amount of adjustment is not achieved with the range obtainable with the pulleys fitted, it will be necessary to change the driven pulley fitted on the blower and possibly the size of the drive V belt. **After adjustment ensure the motor load rating is not exceeded!**

6.5 **LIGHTING**

- Ensure that air discharge grilles dampers etc. are set to open.
- Turn on gas supply.
- Switch on electrical supply.
- Set time switch (if fitted) to an 'ON' cycle.
- Set room thermostat to 'ON' position.
- If reset button on remote control glows, press reset button.
- Heater should now light automatically within 1 minute. after a further period the air circulation fan should run, (see also below: "operation" point 6.6.6).
- For a new installation or if the appliance has been turned off for an extended period then up to 3 attempts to light the air heater may be necessary. If the heater still does not light, consult the fault finding guide section 9.

6.6 **OPERATION** Refer to figure 25.

6.6.1 At the dictates of the external controls, an electrical circuit is made and the combustion air fan ("venter") runs.

6.6.2 Provided adequate air flow is proved, the fan will continue to run approximately 30 sec. (pre-purge period).

6.6.3 EUROPAK air heaters employ the direct burner ignition principle. A hot surface igniter will glow for ± 15 seconds, after which time the gas valve(s) will open and the burner will be lit.

6.6.4 If the burner has not lit within 5 seconds, the electronic flame relay will switch off and lockout will occur. This will cause the signal lamp to glow in remote control. After 10 seconds the reset button on the remote control can be operated in order to reset the appliance.

6.6.5 Flame failure protection is by the ionisation principle i.e. the ability of a suitable flame to pass an electrical current between the igniter and the earthed burner assembly. To check the flame current is adequate, remove jumper between terminal 17 and 18 on the automatic burner control, connect a DC micro ammeter between the terminals. Ionisation current should be $\geq 2\mu A$.

Note: The terminals carry mains voltage when energised.

6.6.6 Simultaneously to the ignition circuit and gas valve circuit being energised, electrical power is supplied to an anticipator within the air circulation thermal fan control.

The air circulation fan will start after about 2 minutes and warm air at a temperature of approximately 40°C is now discharged from the appliance. PRPV models may be fitted with a constant running fan feature therefore, the fan will run continuously throughout an appliance **ON** period at the dictates of a time switch.

6.6.7 In the event of the combustion air volume falling below a safe level, the burner will be extinguished a re-start cycle will commence after adequate combustion air volume has been restored.

6.6.8 If the burner flame is extinguished for any reason during a run cycle, an automatic attempt for re-ignition will take place, if the burner does not relight then safety shut down and lockout will occur. Manual intervention to reset is necessary to put the air heater back into service.

6.6.9 In the event of overheating for any reason, thermally activated fail safe overheat controls operate to switch off the burner.

The first control (LC1) switches off the burner and upon its cooling, automatically resets and the lighting sequence starts automatically.

The second control (LC3) which operates at a higher temperature setting, will switch off the burner and itself set to a lockout condition which also requires manual intervention to reset to restore the heater to operational condition. A cooling time of ± 1 minute is necessary before thermal re-setting can be carried out

6.6.10 When the set temperature or the heating time period has been reached, electrical power to the burner relay will be switched off and the burner will extinguish. The air fan will continue to run until the heat exchanger has been cooled down to a safe level, except for RPVJ models fitted with constant run fan feature.

6.6.11 To turn off the air heater for a short period,
a. turn room thermostat to lowest setting.
To relight reset thermostat.

For prolonged period;

a. turn room thermostat to low setting,

b. turn gas supply to the appliance off.

c. switch off electricity supply to the air heater
after air circulation fan has stopped.

To relight follow lighting instructions.

NOTE: Air circulation fan will continue to run on EUROPAK models until a timed cycle period expires. If it is required to turn **OFF** the fan then wait 5 minutes after the burner has been switched OFF then turn **OFF** at the electrical isolator to the appliance.

6.6.12 The gas service tap must only be operated in emergencies, for servicing or prolonged periods of shutdown of the air heater.

6.6.13 The model EUROPAK PRPV/J is fitted with a two stage burner and duct thermostat. If the set point of the duct thermostat is reached the air heater will automatically switch to low fire 50% rate. If the low temperature set point is reached the burner will automatically be switched **OFF** the fan will continue to run see point 6.6.11 above.

6.6.14 When heat is called for the burner will always start at high fire rate regardless of the dictates of the control thermostat, this is to ensure that burner cross lighting takes place quickly and smoothly. If demanded to do so, switching to low fire will occur after approximately 3 seconds controlled by the relay K 1.2.

SECTION 7 TWO STAGE BURNERS SETTING AND ADJUSTMENT

7.1 The EUROPAK RPVJ air heaters are equipped with two stage burners as standard specification. this feature is an option for the E version the type of gas control fitted is the "Honeywell" VR 4601P/B with V 4336A 2 stage regulating governor a two-stage pressure governor. Regulation is possible for the pressure range 2 - 20 mbar for natural gas and 4 - 37 mbar for propane/butane gas. The appliances are fitted with a relay to ensure that during burner start-up the initial firing rate is 100% to ensure good burner cross-lighting (see 6.6.14 above).

Figure 19. Two stage pressure adjustment

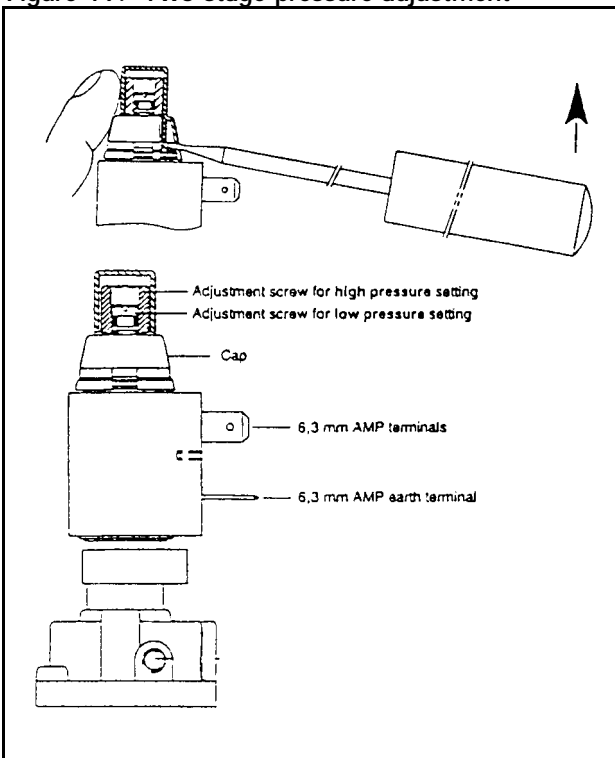

7.2 Setting. Refer to figure 19.

NB. Allow time for pressure to stabilise before and during making adjustments.

- Lever off the plastic cover cap
- Maximum high rate setting **must** be adjusted first after which the minimum low rate setting can be adjusted. Any adjustment of the maximum setting influences the minimum setting.
- Do not adjust maximum or minimum settings above or below the pressures stated on the air heater data plate or table 10.
- Before commencing an adjustment connect a manometer to the burner pressure test point.
- Remove cover-cap from pressure governor

Adjusting maximum pressure setting

- Energise high/low regulator, set gas control in operation and wait until an outlet pressure is recorded on pressure gauge.
- Use a 6 mm hexagon wrench or a 10 mm screwdriver to turn adjustment screw for **maximum** pressure setting clockwise to increase and counter-clockwise to decrease pressure until desired maximum pressure is obtained.
- Check maximum pressure setting several times.

Adjusting minimum pressure setting

- Disconnect electrical connection of high/low regulator.
- Set gas control in operation and wait until an outlet pressure is recorded on pressure gauge.
 - If minimum pressure setting needs adjustment then use a 3.5 mm screwdriver to turn adjustment screw for **minimum** pressure setting, clockwise to increase or counter-clockwise to decrease pressure, until desired minimum pressure setting is obtained.
- Re-connect high/low regulator in circuit.
- Check **maximum** pressure setting, re-adjust if necessary and check minimum pressure again replace governor cap when finished.
- It is necessary to recheck pressure settings during the annual service of the appliance.
- Do not adjust maximum or minimum settings above or below the pressures stated on the air heater data plate or table 10.

Table 10. EUROPAK Models. High/Low burner gas pressures and low rate consumption values

EUROPAK				SINGLE BURNER SECTION 2095/2595
Burner Pressure	Pressure @ 100%	Nat. G 20	mbar	8,5
		Bu. G 30	mbar	28,0
		Pro. G 31	mbar	37,0
	Pressure @ 50%	Nat. G 20	mbar	2,2
		Bu. G 30	mbar	7,0
		Pro. G 31	mbar	9,2
Gas consumption @ 50% Reference 15° C, 1013 mbar	Nat. ¹ G 20	m ³ /h	5,50	
	Bu. G 30	kg/h	4,21	
	Pro. G 31	kg/h	4,13	

1 Natural gas G 20 calorific value 10.48 kWh/m³ @ 15° C & 1013 mbar
 Butane gas G 30 calorific value 13.70 kg/h
 Propane gas G 31 calorific value 14.0 kg/h

Note: Burner pressures for Butane/Propane gasses are approximate based on regulated supply pressure.
 Low fire rate must not be reduced below the values stated above for 50% rating.

SECTION 8. SERVICING

8.1 **For safety it is not recommended to carry our service work in wet weather conditions.**

8.2 **General**
 Before commencing servicing, turn off the main gas supply and switch off the main electricity supply after the air circulation fan has stopped.

8.3 It is recommended that maintenance is carried out at least once a year. More frequent servicing may be required dependent upon the environmental circumstances where the air heater is installed. Regular inspection is necessary, especially in dirty environments, to assess the servicing frequency.

8.4 Check for security and worthiness of the appliance mounting system, gas service and electrical service.

- 8.5 To gain access to the controls and flue gas fan assembly refer to figure 20.
- remove screw securing the gas inlet seal plate key 5;
 - unlatch cam fastener key 3, ¼ turn counter clockwise, remove burner access panel;
 - remove screw securing seal plate around the flue outlet on the upper panel key 2;
 - remove screws in the outlet pipe behind the above referred cover;
 - push panel downwards to remove.

All controls, electrical and flue gas components are now accessible.

8.6 Clean both panels thoroughly and ensure that water drain holes, combustion air inlet and flue are unblocked.

8.7 Remove all dust and dirt from combustion air fan (venter) see figures, 21 & 25. If dismantling venter observe critical dimension from figure 22 when re-assembling. Note that the venter motor is lubricated for life and does not require greasing.

8.8 Inspect hot surface igniter fig.24 replace if in doubt about its condition.

Note: The igniter device is fragile, therefore, handle carefully.

8.9 Inspect and clean the burner assembly, refer to fig. 23 for how to remove the burner.

8.10 Inspect heat exchanger and clean as necessary. This can only be done after removing the burner assembly. The inside of each element of the heat exchanger can be cleaned by use of a soft brush and compressed air.

8.11 Clean burners and gas jets with soft brush and compressed air. To prevent damage, do not use hard objects for cleaning the gas injectors. Solid and/or sticky deposits should be removed using acetone as a solvent.

8.12 Upon completion of any service work it is necessary to recommission the appliance in accordance with the step procedure described in section 6.2 of this document.

8.13 To remove the combustion air fan;

- disconnect electrical connections to fan motor;
- remove motor and fan wheel 3 screws;
- withdraw motor/fan impeller assembly sideways;
- clean fan housing;
- check, clean or replace motor and/or fan wheel;
- replace parts in reverse order after checking dimensions given in figure 22.

Figure 20. CONTROLS ACCESS KEYS

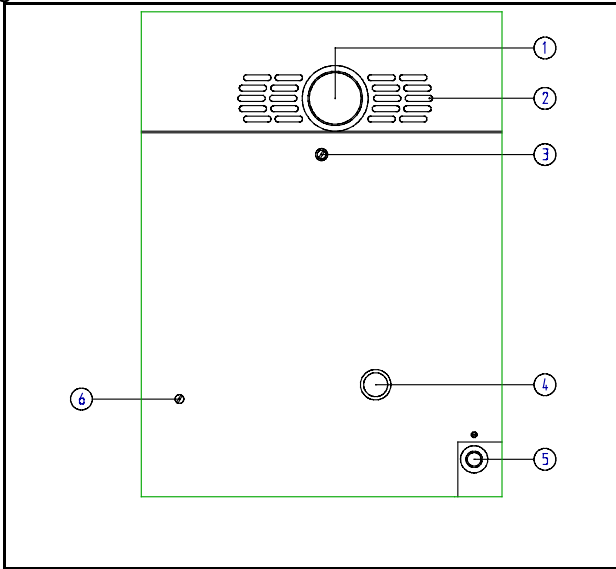

Legend for figure 20

1. Flue outlet
2. Combustion air inlet
3. Burner access panel fastener
4. Burner inspection port
5. Inlet gas connection
6. Inlet temperature sample point

Table 11 . FILTER SIZES AND QUANTITIES SCHEDULE

EUROPAK Model size	Filter element size mm X 25 mm nominal thickness			Reznor part number
	Quantity required	Length	Width	
..10 & ..20 For section cabinets 1.1	2	495	495	60 60145 495495
	2	622	495	60 60145 622495
	1	495	394	60 60145 495394
	1	622	394	60 61045 622394
..11 & ..22 For section cabinets 1.1	4	495	495	60 60145 495495
	4	622	495	60 60145 622495
	2	495	394	60 60145 495394
	2	622	394	60 61045 622394

Table 12. FILTER SIZES AND QUANTITIES SCHEDULE

EUROPAK Model size	Filter element size mm X 25 mm nominal thickness			Reznor part number
	Quantity required	Length	Width	
..10 & ..20 For sections 3.1/3.2	6	495	495	60 61045 495495
	3	495	394	60 61045 495394
..11 & ..22 For sections 3.1/3.2	12	495	495	60 61045 495495
	6	495	394	60 61045 495394

NB. EUROPAK APPLIANCES WILL ONLY OPERATE WITH ALL PANELS CORRECTLY FITTED

FIGURE 21. FLUE GAS FAN (VENTER) ASSEMBLY DETAILS

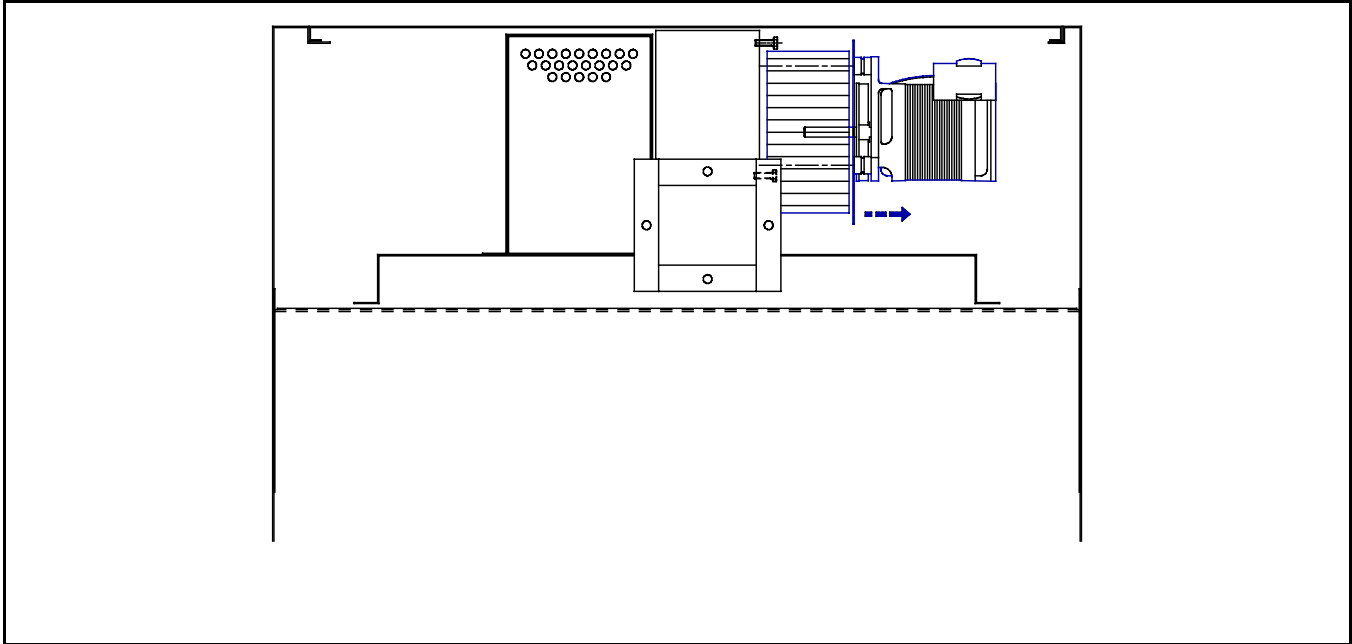

FIGURE 22. VENTER CRITICAL DIMENSIONS

FIGURE 23. BURNER REMOVAL DETAILS

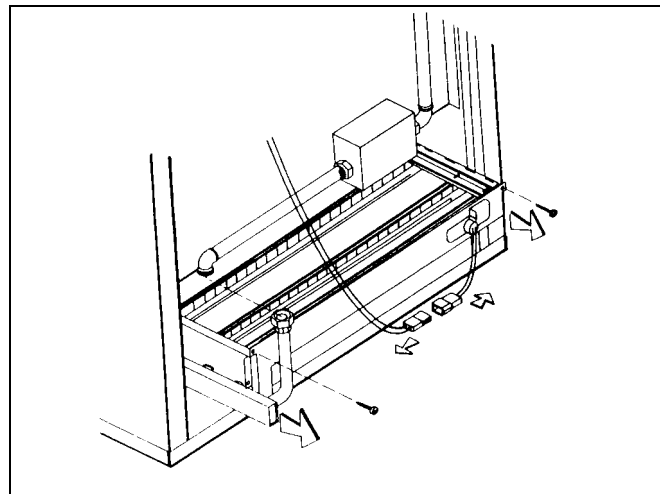
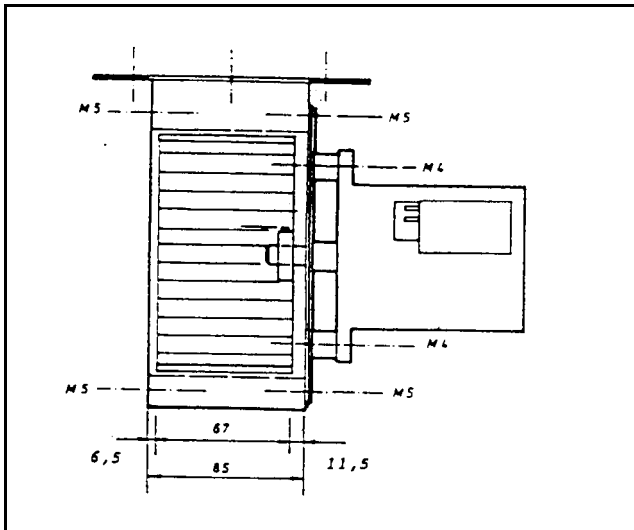
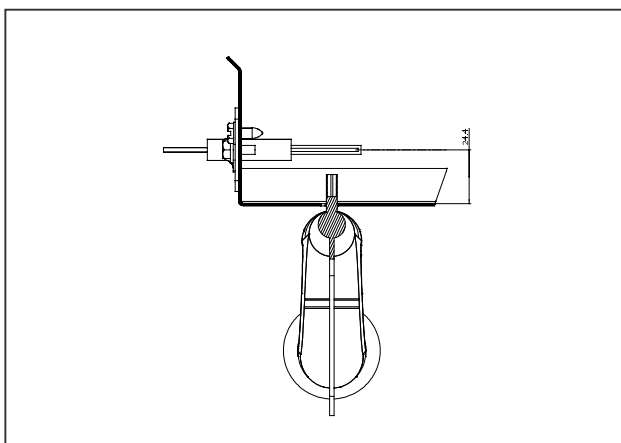

FIGURE 24 HOT SURFACE IGNITER

Re: Fig 23 TO REMOVE THE BURNER ASSEMBLY



1. Disconnect burner manifold at union provided
2. Remove igniter assembly from burner tray
3. Remove two (2) screws securing the burner tray
4. Withdraw burner tray by pulling forwards.

FIGURE 25.

PARTS LOCATION DIAGRAM. MODEL RPVE/J SHOWN

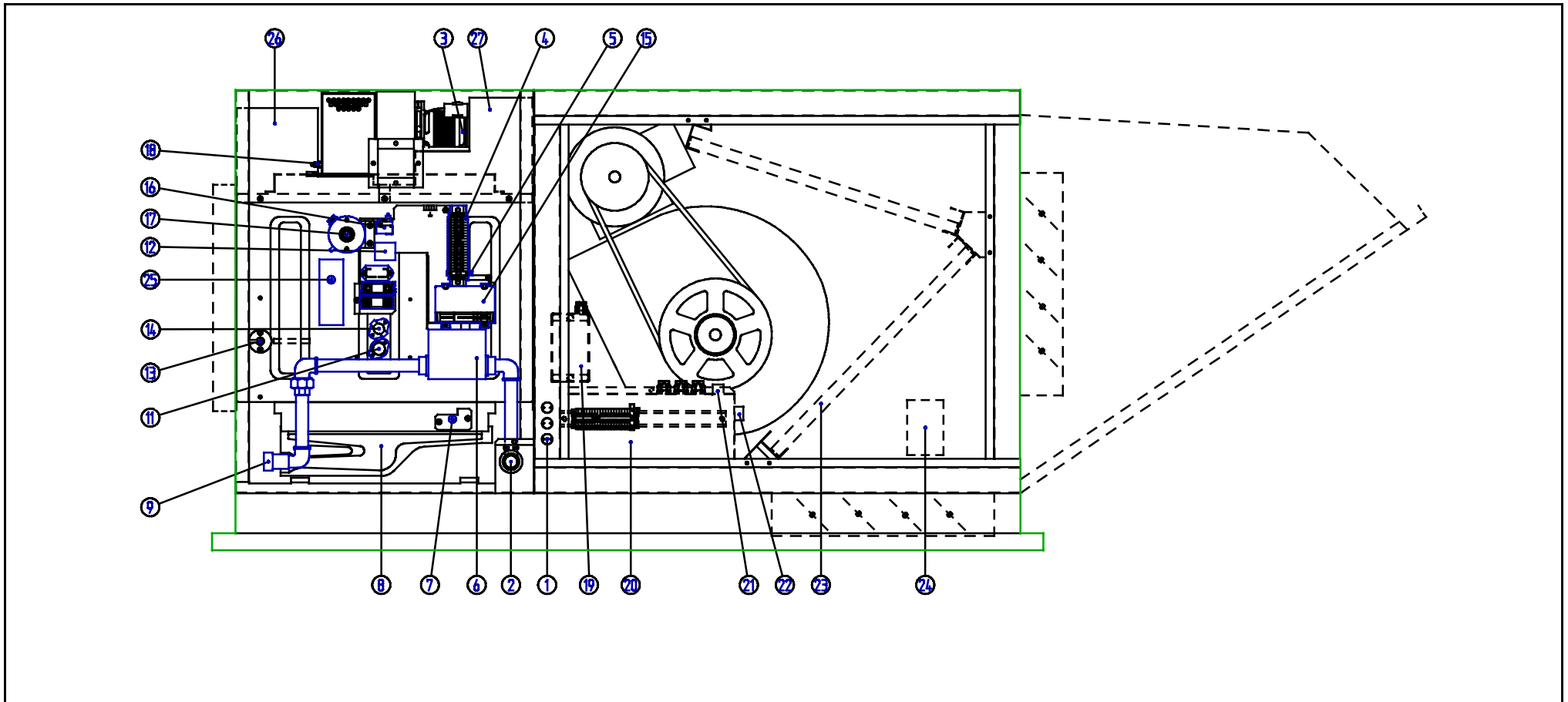

Legend figure 25

- 1. Electrical and controls inlet
- 2. Gas inlet Rc $\frac{3}{4}$
- 3. Flue gas fan (venter)
- 4. Main terminal rail
- 5. Fuse
- 6. Multi-functional gas valve
- 7. Hot surface ignition assembly
- 8. Burner ribbon

- 9. Burner manifold & test nipple
- 10. Not used on RPV appliances!
- 11. Thermal fan control
- 12. Not applicable for GB - IE
- 13. Overheat control LC3 capillary
- 14. Thermal over heat control LC1 (LC2)*
- 15. Automatic burner control
- 16. Thermal overheat control LC3
- 17. Combustion air proving device

- 18. Combustion air pressure reference point
- 19. 3 phase motor starter and overload
- 20. Supplementary wiring box three phase
- 21. Air flow proving device
- 22. Dirty filter indicator
- 23. Filters
- 24. Servo damper motor
- 25. Duct thermostat
- 26 & 27. Combustion air baffles

SECTION 9 FAULT FINDING

9.1 Burner does not ignite

- Thermostat set too low or time switch not correctly set - no power to terminals 2 and 5;
- fuse F3 has blown - no power to terminal 2 and LC3;
- reference tube to differential air pressure switch S3 is not airtight or blocked - (condensation ??);
- faulty differential air pressure switch S3 - no power to terminals 2 and 13;
- burner relay in lockout (point 2 below) or faulty;
- faulty combustion air fan M3 (venter);
- faulty limit control LC1 - no power to terminal 2 and LC1;
- overheat control LC3 in lockout - no power to terminal 2 and LC3 - Reset manually;
- faulty 2 pole relay (2 stage only)
- faulty motor starter (3 phase only)

9.2 Flame relay in lockout

- Air in gas service - purge;
- low gas pressure - adjust;
- faulty hot surface igniter;
- faulty differential air pressure switch;
- gas valve does not open - no power to terminals 2 and 7;
- insufficient ionisation flame current - ionisation current $\geq 2\mu\text{A}$;
- incorrect wiring of mains input line, neutral, earth.

9.3. Combustion air fan (venter) does not start

- Faulty motor or capacitor;
- faulty burner relay;
- differential air pressure switch S3 still in normal run position has not changed over;
- faulty fuse F3.

9.4 Differential air pressure switch switches burner off

- Switch-point should be - ON 104 Pa, OFF 94 Pa;
- no differential pressure in flue gas system - check air inlet;
- faulty combustion air fan or capacitor;

9.5 Appliance does not provide sufficient warm air

- Check gas inlet pressure;
- check burner pressure;
- gas filter (if fitted) dirty or blocked;
- limit control (LC1) switches burner off (see 6.6.9);
- differential pressure switches relay off (see 6.6.7);

9.6 Limit control LC1 switches burner off

- Switch temperature 51,5°C;
- insufficient air flow;
- air distribution grilles or dampers closed;
- burner overload - check burner and inlet gas pressures;
- fan control switch faulty;
- check fan rotational direction;
- air temperature at fan inlet too high ?
T max. 30 °C (see 6.6.9).;
- thermal contact in fan motor switches off intermittently.

9.7 Limit control LC3 switches

- Switch temperature 96°C (+ 0/-5);
- check location and security of capillary and probe;
- air discharge temperature too high (see 6.6.9);
- faulty limit control LC1;
- air fan stops immediately after burner is switched off; incorrect control/s wiring;
- faulty fan control (FC).
- faulty motor starter
- incorrect setting of motor starter over-load

9.8 Air fan does not start

- No power to terminals 2 and 11;
- faulty fan control (FC);
- faulty motor or capacitor;
- thermal over-load in motor switching.
- faulty motor starter
- incorrect setting of motor starter over-load

9.9 Fan starts and stops intermittently while burner is on.

- Faulty heat anticipator (FCR) in fan switch;
- thermal over-load in motor switching;
- inlet ambient air temperature too low - T min. $< 5^\circ\text{C}$.; will correct as space temperature rises;
- faulty wiring connection - loose terminals!.

SECTION 10. SPARE PARTS LIST

10.1 GAS SECTION

DESCRIPTION	PART NUMBER	MFGS.REF.	APPLICATION
Gas valve	03 25136	Honeywell VR4601AB	2095
Gas valve	03 35136	Honeywell VR4601PB	2 stage
Gas jet Main burner	07 25801 024	φ 2,4 mm	2095 NG
Gas jet Main burner	07 25801 135	φ 1,35 mm	2095 LPG

CODES: NG = Natural gas G20 LPG = Butane gas G30 or Propane gas G31

10.2 ELECTRICAL SECTION

DESCRIPTION	PART NUMBER	MFGS.REF.	APPLICATION
Thermal fan control FCR	03 25166	TOD29T12 (250V)	All
Thermal over-heat control (limit) LC1	03 24970	TOD60T11	
Thermal over-heat control LC3	03 24959	limit 96° C	All
Combustion fan motor wheel assy.	36 79090	Drouard-Tec CP 78	All
Combustion circuit pressure switch	30 30607 94	Honeywell C6065 FH1193	ALL
Automatic burner control	03 25317	Honeywell S4570LS	All
Hot surface igniter assembly	36 25217	Norton 240V	All
Two pole relay K1.2	30 61736 240V	Omron LY2	All two stage burners
Wiring harness for burner control	06 41531 HGC	----	All
Wiring connector for igniter device	06 41531 HGC	----	All
Wiring harness for two stage burners	06 41621	----	All
Wiring terminals	06 41635	Entrelec	All
Reset switch/burner fail lamp	60 61988	----	All
Isolation transformer (not GB)	30 61610	3VA-E11TF102	When applied

10.3 AIR HANDLING SECTION

DESCRIPTION	PART NUMBER	MFGS. REF.	APPLICATION
Blower housing 15 X 11	20 25740	Nicotra	All
Impeller 15 X 11 X 30 mm	2025741	Nicotra	Drives ≤ 5.5 kW
Impeller 15 X 11 X 40 mm	20 25741 40	Nicotra	Drives 7.5 - 15 kW
Bearing support for RSCM 30 Ø 30 mm	20 25744	Nicotra	Drives ≤ 3,0 kW
Rubber mounting bearing Ø 30 mm	20 70142	INA RSCM 30	Drives ≤ 3,0 kW
Pillow block bearing Ø 30 mm	20 70148	INA 30 FA 106 RASE	Drives 3,0-5,5 kW
Pillow block bearing Ø 40 mm	20 70150 40	ASAHI UKP 209 + H	Drives 7,5-15 kW
Flexible coupling Ø 40 mm	20 70151 40	REXNORD OMEGA E20M	Drives 7,5-15 kW
Blower shaft Ø 30 mm X 1290 mm	80 70146		Drives to 5,5 kW
Blower shaft Ø 30 mm X 2755 mm	80 70147		Drives to 5,5 kW
Blower shaft Ø 40 mm X 1390 mm	80 70148 40P01		Drives 7,5-15 kW

NOTE: State quantities of parts required and serial number of appliance

10.4 MISCELLANEOUS SECTION

DESCRIPTION	PART NUMBER	MFGS. REF.	APPLICATION
Combustion air fan impeller	02 25730	Punker	All
Sampling pressure test point	07 25811 02	M8	All
Silicon tubing	06 20224 cm	φ 5-8 mm x 1.0 m	All
Combustion fan assembly gasket	11 44696	---	All
Capillary seal plate assembly	08 07727	---	All
Differential pressure switch, air flow proving &/or clean filter control	30 60615	Huba 604 9000 130	All if options fitted
Air filters	see tables 11 & 12 page 21 for details, sizes and part numbers		

ALWAYS QUOTE MODEL, SIZE, TYPE & SERIAL NUMBER WHEN ORDERING SPARES

SECTION 11. GAS CONVERSION

- 11.1 This air heater is designed to operate on natural, propane or butane gas and will be supplied as ordered for the gas type specified. In the event it is required to convert to a different gas type to that which has been supplied, conversion of the gas burner must be carried out.
- 11.2 A Reznor approved conversion kit to suit the appropriate gas type must be used.

- 11.3 In addition to changing the burner injectors, and adjusting the gas pressure, sealing a governor or fitting a blanking plate it is necessary to fix data plate over stickers as supplied with the conversion kit of parts.
- 11.4 After conversion re-commission appliance according to section 6 of this document.

Figure. 26 BURNER AIR SHUTTER AND SETTING DIMENSION for all GASES UK & IE

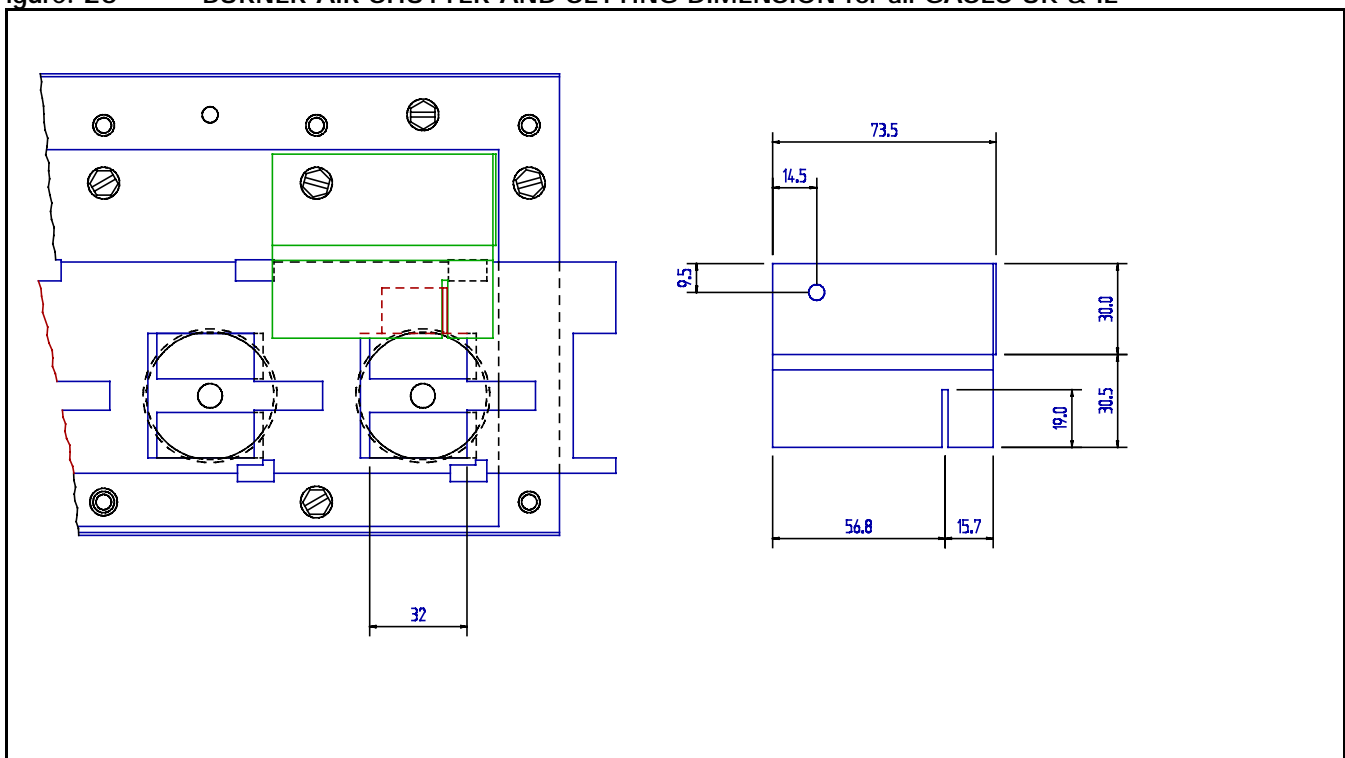

SECTION 12. HEALTH & SAFETY STATEMENT

Health and Safety Information for the Installer and Commissioning-Service Engineer

12.1 General

Under the Consumer Protection Act 1987 and Section 6 of the Health and Safety at Work Act 1974 we hereby provide the following information on substances hazardous to health. Product range reference EUROPAK RPV Series air heaters for outdoor use.

12.2 Important notice

Maintenance and/or Service work should not be carried out on these appliances during wet weather conditions. Always ensure that a second person is available to assist in the event of an **emergency**.

12.3 Cautionary note

During first firing some smoking may occur, this is due to the burning off of protective/lubricating oils used during appliance production. Most of this will have been removed during the production testing process. It is a wise precaution to ensure that adequate ventilation is provided during the initial firing and throughout the commissioning period, this is particularly important if the discharge air is to blow into a confined space. This smoking does not constitute a poison hazard.

First Aid: Medical attention must be sought following eye contact or prolonged reddening of the skin.

12.7 Thermostat. (Thermal overheat (limit) control LC3)

Material: Illuminating Kerosene.

Description: Sealed phial contains a small quantity in liquid form.

Recognition: Colourless liquid, paraffin oil/petroleum hydrocarbon odour.

Characteristics: Non-corrosive, flammable with no poisonous reference-CH poison Class 3

Precautions: Avoid handling. This product can irritate and de-fat the skin. Prolonged contact may cause dermatitis. Avoid breathing vapour. Avoid eye contact. Do not ingest.

First Aid: Skin. Wash thoroughly with soap and water.

Eyes. Rinse immediately with copious amounts of clean water.

Ingestion: Seek medical advice.

NOTE: If skin irritation persists seek medical advice.

12.4 Declaration

Reznor products contain no asbestos; copper is not employed in gas carrying components; solder which has a melting point below 450°C is not used; paints for corrosion protection and decoration are heat cured and contain no lead.

12.4.1 The above appliances meet the Electrical Safety requirements of EN60 335 Pt 1 1988.

12.5 Miscellaneous

Small quantities of adhesives and sealants used in the product are dried and cured and present no known hazard.

12.6 Insulation and Seals.

Material: Alumino - silicon fibre

Description: Tapes

Known hazards: Some people can suffer reddening and itching of the skin. Fibre entry into the eyes will cause foreign body irritation. Inhalation will cause irritation to the respiratory tract.

Precautions: Wear protective gloves when handling.

People with a history of skin complaints may be susceptible to irritation.

Dust levels are only likely when the material is abraded.

In general normal handling and use for this purpose will not present discomfort. Follow good hygiene practices, wash hands before consuming food or using the toilet.

12.8 Electrolytic Capacitor

Two types are used by random selection:

Recognition: 1. Plastic enclosure 2. Aluminium enclosure

Material: Contained liquid electrolyte;

Known hazards: Electric shock possible if charged.

Precautions: Discharge to ground/earth. Do not incinerate.

First Aid: Treat for electric shock if affected.

END OF HEALTH AND SAFETY STATEMENT

SECTION 13. USER INSTRUCTIONS

EUROPAK RPV OUTDOOR GAS FIRED AIR HEATERS

13.1 OPERATING

How the air heater works:

Gas is burned by an atmospheric burner which fires into a heat exchanger. The gas burner is controlled by a double gas valve via an electronic burner control, which is actuated automatically via external controls i.e. a room thermostat and/or a time switch. The burner is ignited by a hot surface igniter. When the burner fires and warms the heat exchanger, the heat is sensed by a thermally actuated fan control which switches on the fan when the air temperature has reached its preset operating level.

At the end of a heating cycle the burner is switched off, the air circulation fan will continue to run until the air heater has cooled to a safe condition. Thereafter, the fan will remain off until the next cycle is initiated, (except for EUROPAK with constant run fan feature).

Safety:

1. Flame failure is detected by the hot surface igniter which is also the sensor and will immediately result in gas valve shut down.
2. Safety against overheating is assured by two overheat controls. The first is an automatic recycle control which protects against low air flow i.e. clogged air ways, fan failure etc. The second, which is set to a higher level than the first one, is a control which locks out and switches off the burner in the event of gross overheating for any reason. Manual intervention is necessary to reset this control device. Resetting of the automatic burner control may also be required.

13.2 To light the heater:

1. Turn on the gas supply to the air heater.
2. Switch on the electricity supply to the air heater.
3. Ensure time switch (if fitted) is set to a 'ON' cycle.
4. Adjust control/room thermostat to desired temperature.

5. Air heater will light automatically when the room thermostat calls for heat.
6. If the appliance does not light:
 - a) check that the burner control does not require resetting. An indicator light glows on the remote control. Reset by pushing light/button on the remote control.
 - b) check if thermal overheat control requires resetting (see fig. 25, key 16).
7. If the thermal overheat control requires resetting and doing so restarts the air heater, wait until the appliance warms to thermal equilibrium, to ensure the overheat control does not lock out again.
If it does and the temperature near the heater is less than 30°C, then switch off the appliance and call for service. If the temperature is over 30°C, take appropriate action to reduce the ambient temperature near the air heater.

13.3 Air circulation:

1. The space heating process is for air to be circulated through the appliance whereby it gains heat from a heat exchanger. The air is directly discharged into the space to be heated via ducting from the appliance.
2. Sometimes the air circulation fan of the appliance is connected to a remote over-ride switch. This enables cool air to be used for circulation purposes when the air heater is not used for heating purposes e.g. in summer.

To use this feature:

- a) switch ON electricity
- b) switch ON manual override switch, this may be fitted as a feature on a remote composite control.

13.4 Maintenance:

1. Maintenance and service must only be carried out by appropriately qualified persons e.g. "Corgi" registered undertakings.
2. It is in your interest to ensure proper service and maintenance is carried out at a regular basis. Periods between service are dependent upon the local environment where the heater

is installed. All gas appliances should be serviced at least once a year.

3. In case of any damage to the appliance, it must be shut down completely and checked by an appropriately qualified person.
4. In the event of difficulties in resolving any of these matters, please do not hesitate to contact Reznor or their official distributor.

END OF USER INSTRUCTIONS

Reznor® EUROPAK RPV

ONE OF THE Reznor GENERATION OF CE MARKED
GAS FIRED ENERGY
EFFICIENT AIR HEATERS

BEST USED WITH Reznor OPTIONAL ELECTRONIC
CONTROL PANELS
SAVE ENERGY AND OPTIMISE THERMAL COMFORT

Reznor® Europe N.V.
J&M Sabbestraat 130
B8930 Menen
Belgium
Tel: +32(0)56 52 95 11
Fax: +32(0)56 52 95 33
e-mail: reznor_europe@tnb.com

Reznor UK Limited
Park Farm road
Folkestone
Kent
CT19 5DR
Tel: + 44 (0)303 259141
Fax: + 44 (0)303 850002
e-mail: sales@reznor.co.uk

Thomas & Betts
