

## INSTALLATION, COMMISSIONING, SERVICING AND USER INSTRUCTIONS

### COVERS MODELS EURO-T 2000 A

Axial fanned, forced convection appliances with  
Automatic Ignition and fanned flues  
for use as: Type B22, C12 & C32 Appliances

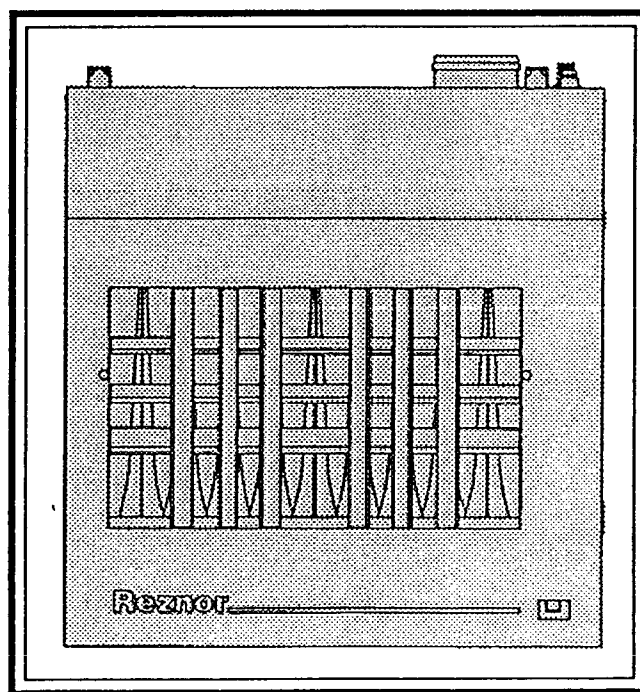

These appliances meet the following EC Directives:

- Dir. CE 90/396/EEC: GAD
- Dir. CE 89/336/EEC: EMC
- Dir. CE 89/392/EEC: MD
- Dir. CE 73/23/EEC: LVD

**Installer:** Please read and understand the contents of this document before commencing installation. This document includes information important to the user and service undertaking. Please leave it with the appliance or attached to the gas service meter for the installation.

## INDEX

Page

1. General	2
2. Technical data	3
3. Installing	5
4. Combustion, Air supply and flue system	7
5. Gas connection	9
6. Electrical connection	9
7. Commissioning, lighting and operation	10
8. Maintenance	11
9. Fault finding	14
10. Spare parts list	15
11. Gas conversion	16
12. Health and Safety Statement	17
13. User instructions	18

If optional equipment was ordered and supplied with this air heater, please refer to additional instructions for option(s).

### SECTION 1. GENERAL

- 1.1 Before installation, check that the appliance as described on the packaging label is in accordance with the correct type and model as specified on the data plate and complies with your customer order.
- 1.2 After unpacking the appliance, leave it fastened to the wooden pallet until it has been suspended or until just before base mounting. This affords protection to the painted underside which is normally exposed to view after installation.
- 1.3 Please read this document before commencing installation.
- 1.4 These instructions are only valid for the country of use indicated on the appliance i.e.: GB - IE. If these symbols are not shown, it is necessary to obtain appropriate technical instructions which will provide information concerning the necessary modification of the appliance for the conditions of use in the country concerned. Such instructions may be obtained upon request from your supplier.
- 1.5 Check that the local distribution conditions of electricity supply, type of gas and pressure, and adjustment of the appliance are compatible.
- 1.6 When installed in Great Britain the total installation must comply with the requirements and recommendations of British Standard BS 6230
- 1.7 1991. "Installation of Gas Fired Forced Convection Air Heaters for Commercial and Industrial Space Heating".  
The Installation must also be in accordance with the relevant requirements of "The Gas Safety (Installation and Use regulations) and (Amendment Regulations 1990)" and The "Building" and "Electrical Regulations" (in GB the IEE Regulations). The requirements of the "Local Building Standards Office", the premises "Insurance" undertaking and the "Fire Office" must also be observed.
- 1.8 Unauthorized modification of this appliance or departure from use in the manner for which it was intended by the manufacturer or installation in a manner contrary to these instructions, may constitute a hazard and jeopardize all warranties. Deviations should only be carried out after formal consent has been obtained from the manufacturer.
- 1.9 Ensure the environment in which the air heater will be installed will not create a hazard i.e. where excessive (volatile) dust, flammable or corrosive substances and/or vapours and combustible materials may be present.
- 1.9 This appliance has been tested, and set according to the data plate before leaving the factory.

## SECTION 2. TECHNICAL DATA

**Table 1. Appliance Data Standard Efficiency Models**

EURO-T		Standard Model #	2025A	2030A	2035A	2045A	2055A	2075A	2095A
EURO-T		Low NO <sub>x</sub> #	2525A	2530A	2535A	2545A	2555A	2575A	2595A
Gas category 'Cat.'			II <sub>2H3+</sub>						
Air supply and flue type			B22 - C12 - C32						
Heat input (Hs) 'Qn'	kW		28,8	35,2	42,7	49,9	63,2	86,5	115,4
Heat input (Hi) 'Qn'	kW		26,0	31,7	38,5	45,0	57,0	78,0	104,0
High heat output	kW		22,8	27,8	33,7	39,4	49,9	68,3	91,0
Number of jets			4	5	7	9	12	16	
Jet size	natural gas	∅ mm	2.4		2.2	2.4			
	propane/butane	∅ mm	1.35		1.25	1.35			
Gas supply pressure 'P' <sup>1</sup>	natural gas	mbar	(GB) = 17.5 (IE) = 20.0						
	propane	mbar	37.0						
	butane	mbar	28.0						
Burner pressure <sup>2</sup>	natural gas	mbar	8.50						
Gas consumption	natural gas <sup>3</sup>	m <sup>3</sup> /h	2,74	3,36	4,04	4,76	6,02	8,30	11,00
	propane	kg/h	2,06	2,52	3,05	3,56	4,51	6,18	8,25
	butane	kg/h	2,10	2,60	3,12	3,64	4,61	6,31	8,42
Gas service connection (not supply line size)			Rc ¾						
Temperature rise ΔT (± 1)	K		26		25	29	26	27	31
Air volume <sup>4</sup>	m <sup>3</sup> /h		2500	3100	4000		5600	7300	8700
Throw (terminal V <sub>0</sub> = 0,5 m/s)	≤ m		26		31		32	37	46
Nominal fan speed	rpm		1500			1000			
Sound power level L <sub>w</sub>	dB(A)		70	71	70		74		75
Sound pressure level L <sub>p</sub> <sup>5</sup>	dB(A)		55	56	55		59		60
Electrical supply			230/240V 1 N ~ 50Hz						
Protection grade			IP20						
Fan motor rating	W		200	230	240		400	370	560
*Total electric rating <sup>8</sup>	W		350	380	400		580	530	700
Appliance weight net	kg		101	112	142		157	200	232

**Table 2 Appliance Data Higher Efficiency Models**

EURO-T	Standard Model #	2026A	2031A	2036A	2046A	2056A	2076A	2096A
EURO-T	Low NO <sub>x</sub> Model #	2526A	2531A	2536A	2546A	2556A	2576A	2596A
High fire heat output	kW	23.7	28.8	35.0	41.0	51.9	71.0	94.8
Temperature rise $\Delta T (\pm 1)$	K	27		26	30	27	28	32

Note: All other data as standard model

**Figure 1.**

**DIMENSIONS**

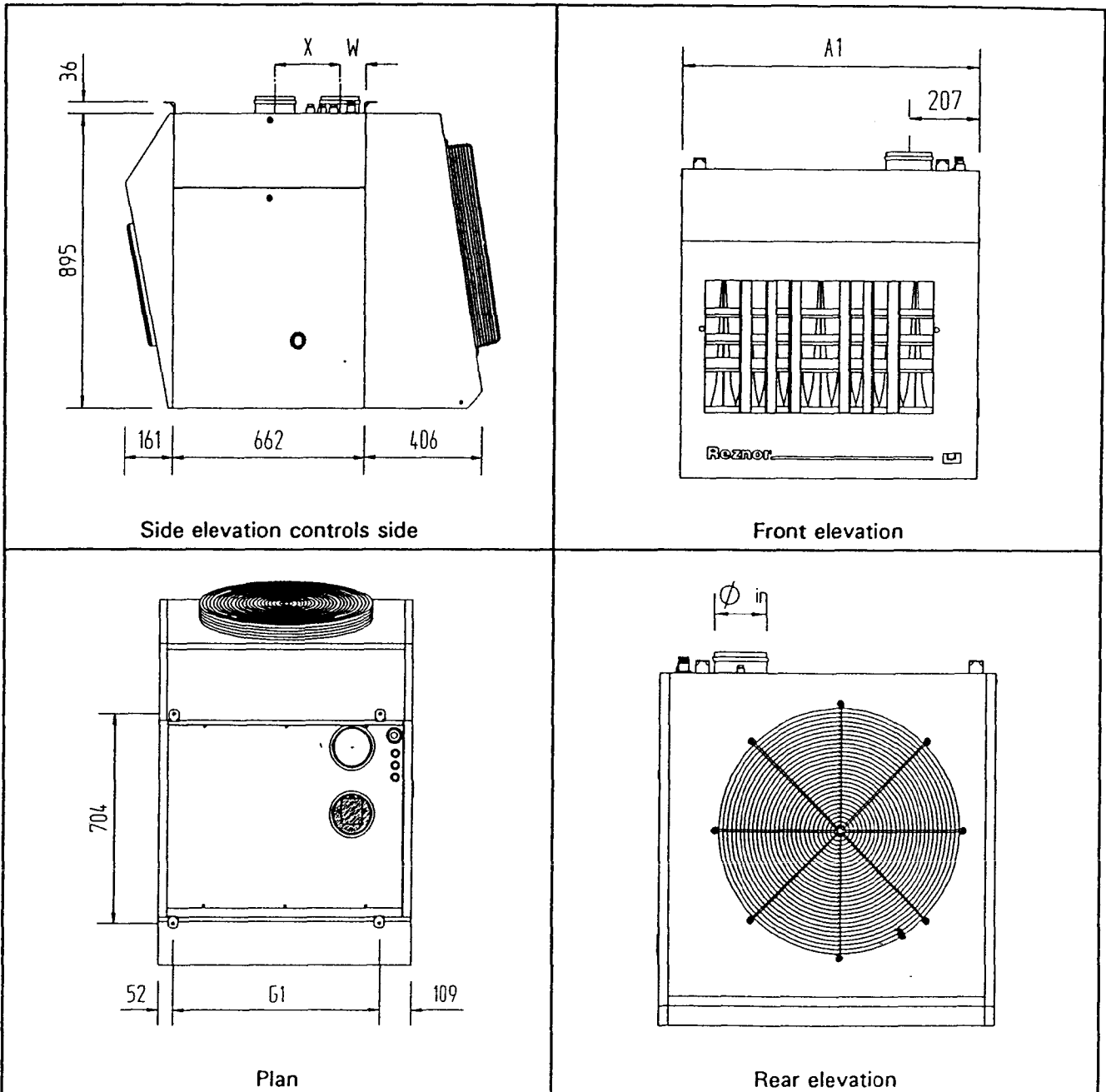

**Table 3**

**Dimensions reference fig.1**

Model	2025 2026	2030 2031	2035 2036	2045 2046	2055 2056	2075 2076	2095 2096
<b>Dimensions</b>							
A1 Width overall	520	590	730		870	1080	1360
Ø Flue & combustion air intake socket internal ø	102			132			
X Flue & combustion air intake socket centres	140			225			
G1 Width of suspension points	359	429	569		709	919	1199

**SECTION 3 INSTALLING**

**Figure 2**

**Suspension & Base Mounting**

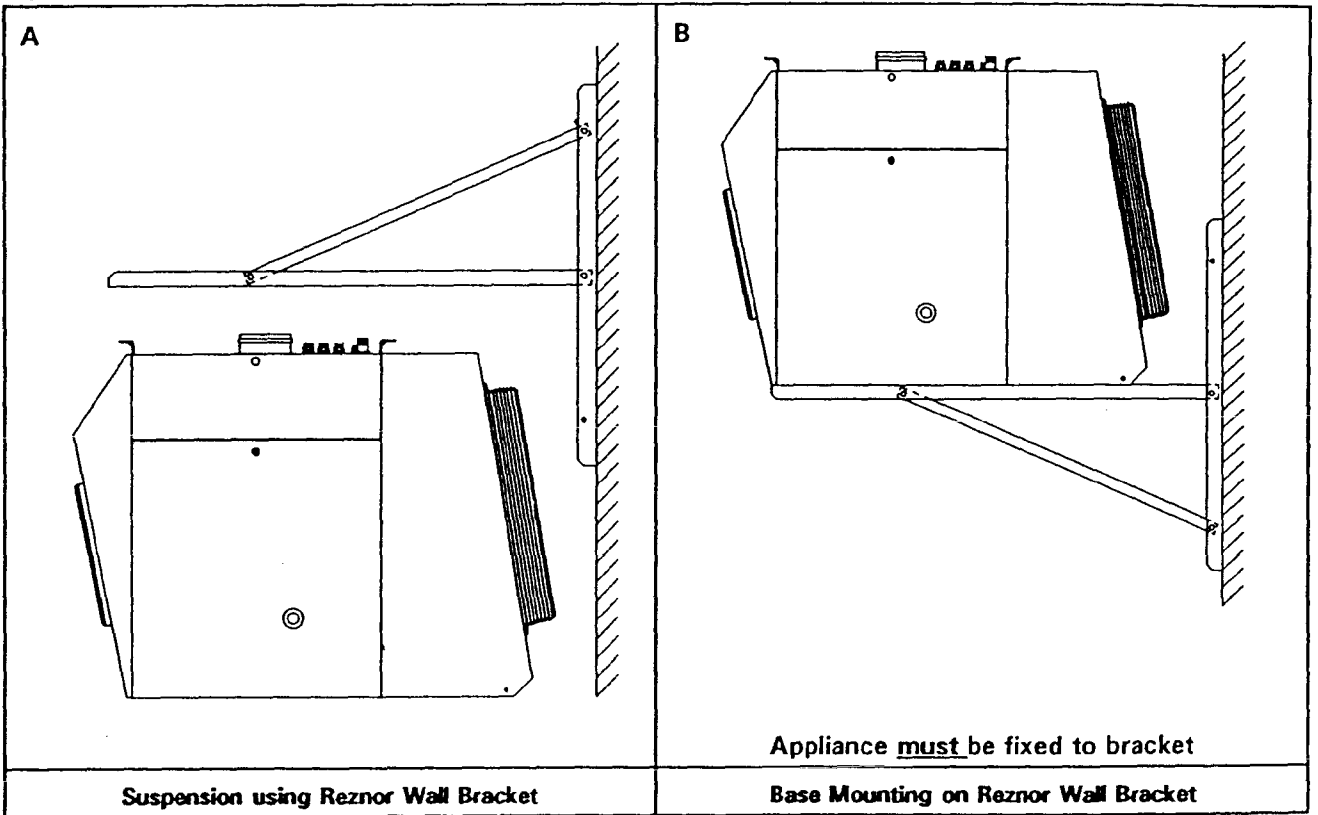

Figure 3

Combustion Clearances & Service Access

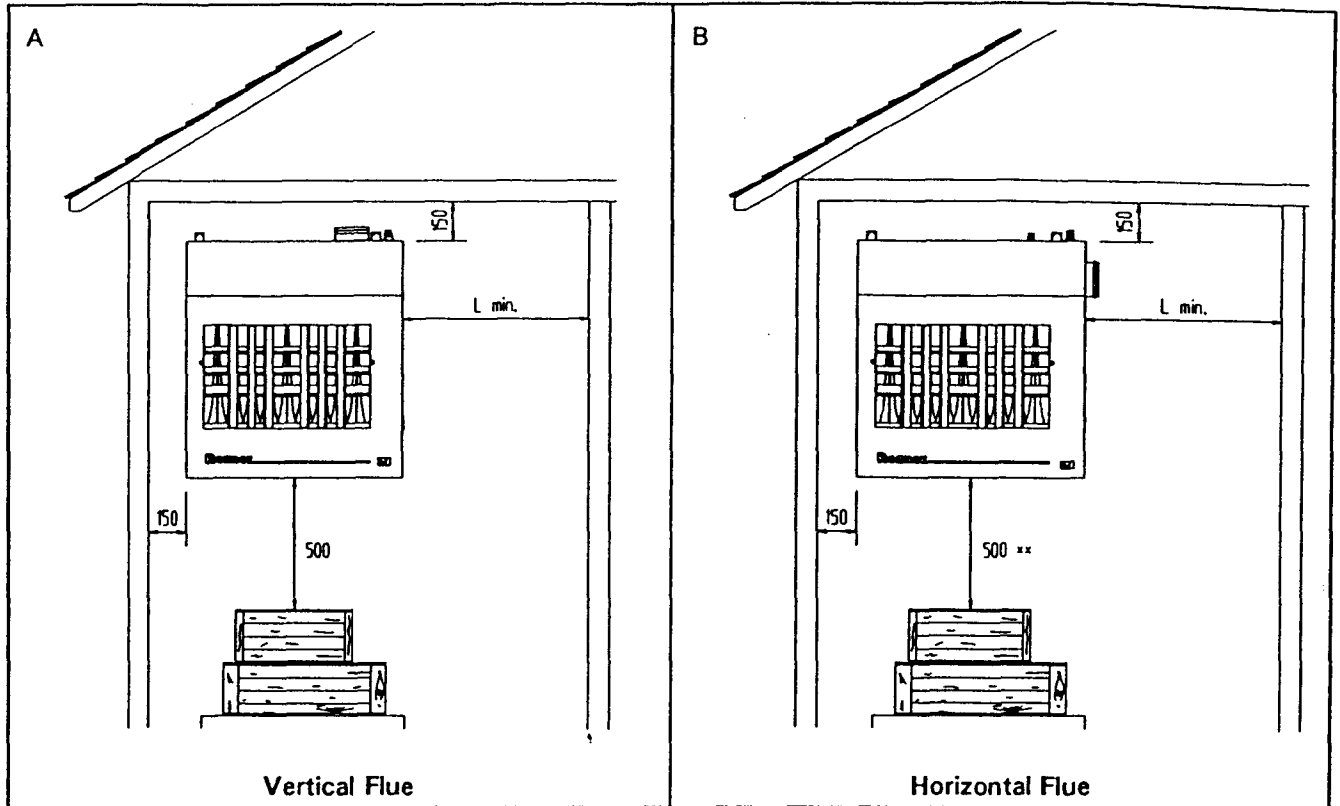

Table 4

DIMENSIONS Re: FIGURE 3

Model	2025	2030	2035	2045	2055	2075	2095
Dims.	2026	2031	2036	2046	2056	2076	2096
L min.	550	620	750	750	900	1100	1400

- 3.1 Figure 3 shows the clearances necessary to ensure safety for combustibles and service access.
- 3.2 Ensure that the structural elements which will be used to suspend or support the appliance, are adequate to carry the weight of the appliance and its ancillary components i.e. flue system.
- 3.3 The location where the air heater is to be installed, must provide sufficient space around the heater for servicing and clearances for safety.
- 3.4 Ensure that the air heater is installed in a level plain.
- 3.5 Base mounting is optional; see fig. 2-B. The air heater must be fastened securely to any base mounting arrangement.
- 3.6 4 suspension brackets with holes  $\varnothing$  10.5 mm are provided on top of the appliance. Use  $\varnothing$  10 mm rods for suspending the heater. Specially designed wall brackets are available from your Reznor dealer.
- 3.7 After suspension, the air heater should be rigid so as to avoid placing a strain on the flue system, gas services and electrical wiring. Optional 1" BSP threaded sockets are available for alternative suspension arrangements.

## SECTION 4. COMBUSTION AIR SUPPLY AND FLUE SYSTEM

- 4.1 Flue systems must comply with national and local regulations.
- 4.2 The products of combustion must be flued to outdoor atmosphere. Common flues for more than one appliance must **NOT** be used.
- 4.3 Combustion air should be taken from out-door atmosphere, this improves the operational efficiency of the heating system.
- 4.4 Flues and combustion air ducts where connected to the air heater must incorporate a disconnect section adjacent to the appliance to facilitate removal of the venter assembly for service and replacement purposes. The flue system must therefore, be supported independantly.
- 4.5 Dimensions and allowances in suggested flueing and combustion air intake arrangements are based upon the use of smooth wall aluminium flue and combustion air ducts and fittings equipped with positive sealing gaskets.

### 4.6 Type C Appliances

- 4.6.1 When using the concentric termination as fig. 4 arrangement, then only an approved system using Reznor specified components may be used. These items are manufactured from seamless aluminium with connection sockets fitted with silicone double edged seals, thus assuring, if the components are undamaged, leak free flue systems.  
**Important:** This type of flue/Combustion air intake system is regarded as an integral part of the air heater therefore, departure from these methods of flueing as published in this document is in breach of the EC Gas Appliance Directive.
- 4.6.2 Distances between the appliance and the concentric flue termination must not be greater than 9.0 m. When calculating the total length the following data must be taken into account:

1 elbow @ 45° = 1 m  
1 elbow @ 90° = 1,5 m.

### 4.7 Type B Appliances

- 4.7.1 If the air heater is to be installed as a B type appliance as fig.5 i.e. air for combustion to be taken from within the space to be heated, then it must be ensured that an adequate air supply for combustion and ventilation is provided, in accordance with the regulations and rules in force.
- 4.7.2 A horizontal distance between air heater and flue terminal and any combustion air intake duct, must not be in excess of 16 m.  
**Note:** 2 Meters of vertical rise negates the

resistance imposed by 1 meter of horizontal run. Runs exceeding 16m may be subject to condensation forming within the flue.

Equivalent lengths of flue fittings:

Elbow @ 45° = 1 m  
Elbow @ 90° = 1,5 m.  
Flue terminal ≤ 3.0 m

- 4.7.3 To ensure that the allowable resistance is not exceeded in the case of horizontal runs of flues, a positive rise from the air heater of 1° i.e. 17 mm per metre is recommended.
- 4.7.4 If condensation is to be avoided, flues should not pass through cold areas or not be installed externally.

continued: on page 9

**WHEN INSTALLED AS A TYPE C APPLIANCE**

Figure 4.

**FLUE AND COMBUSTION AIR INTAKE ARRANGEMENTS**

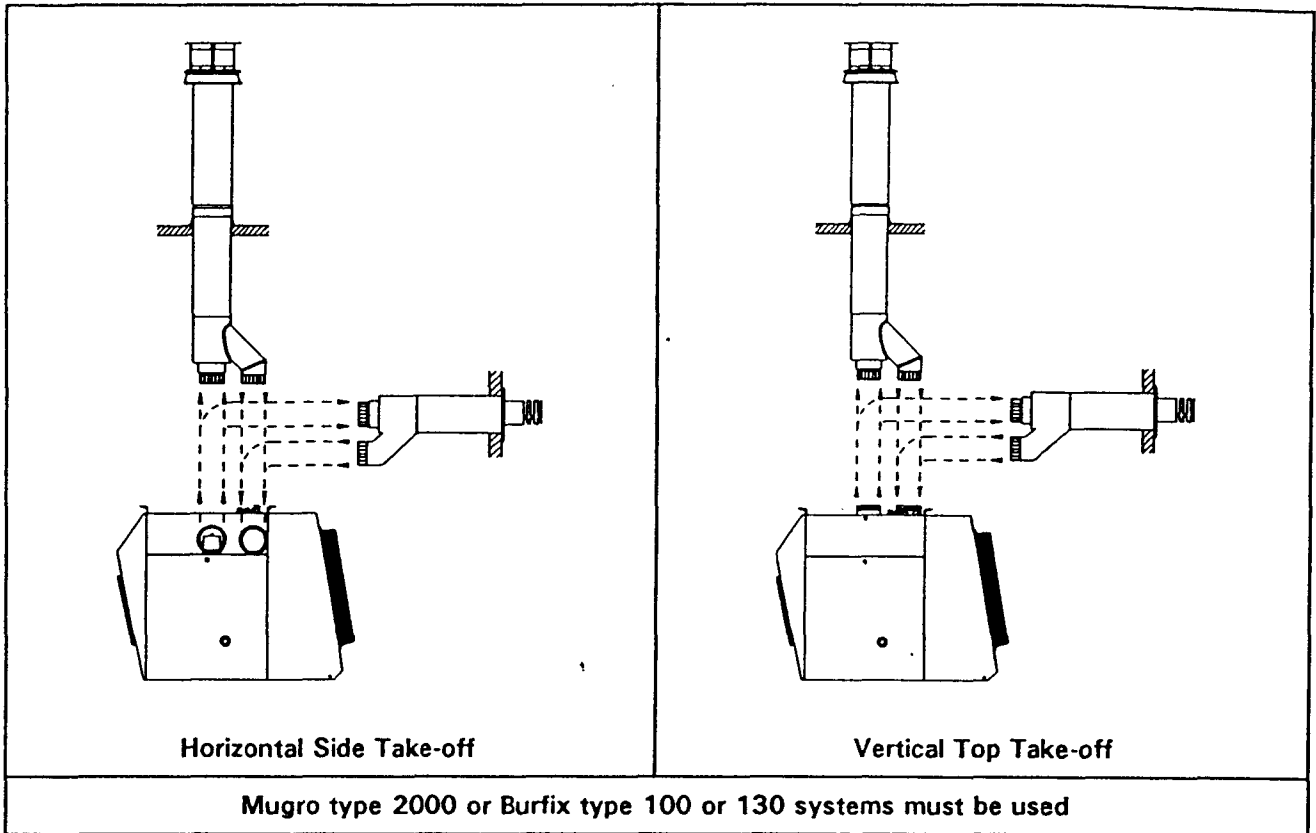

**WHEN INSTALLED AS A TYPE B APPLIANCE**

Figure 5.

**FLUE AND COMBUSTION AIR INTAKE ARRANGEMENTS**

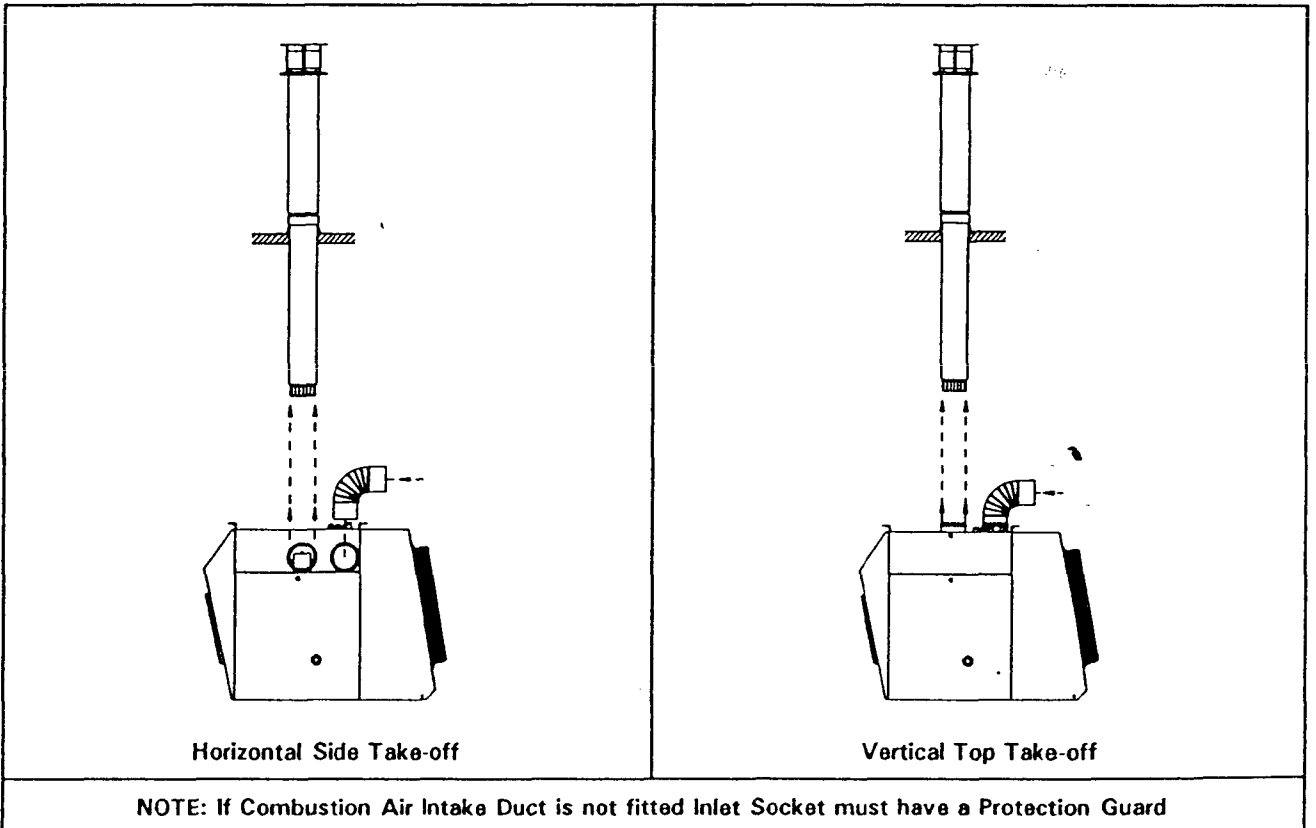



4.7.5 When mechanical ventilation is used, it shall be by mechanical inlet with either mechanical or natural extraction. Automatic means of control such as interlocks must be provided. The function of other ventilation systems in the zone where the air heater is installed must be taken into account. At no time should it be possible to create a negative pressure environment in the zone, this can lead to a

hazardous situation, whereby the air heater flue may act as a pressure relief.

4.7.6 The terminal of a vertical flue must extend at least 1 m above a roof surface; flues must not be located where products of combustion might enter the building. Terminals must be fitted to all flues and combustion air inlets. The combustion air inlet if not used must be protected with an access guard.

## SECTION 5. GAS CONNECTION

- 5.1 Connection to a gas service may only be carried by suitably qualified persons. The gas installation must comply with the rules in force using materials appropriate for gas service installations.
- 5.2 Check that the gas category is in accordance with the data described on the air heater.
- 5.3 An adequate gas supply sized to provide the dynamic pressure for the volume required by the air heater(s) is essential to maintain the nominal heat input.
- 5.4 A 90° action gas service tap and, to facilitate servicing, a disconnect union fitting must be provided adjacent to the appliance, see fig. 6.
- 5.5 Ensure that a gas service includes a filter and has been tested and purged in accordance with prescribed practice prior to commissioning and taking the air heater into service.

Fig. 6 GAS CONNECTION DETAIL

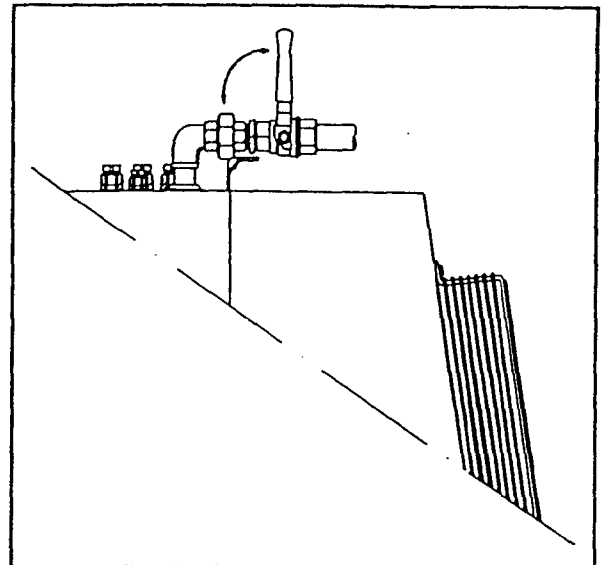

**WARNING: NEVER use a FLAME to test for GAS Soundness !!!**

## SECTION 6. ELECTRICAL CONNECTION

- 6.1 The Electrical installation may only be carried out by suitably qualified persons observing the rules in force.
- 6.2 Check that the electrical specification is in accordance with the specified data on the air heater. A unique appliance wiring diagram is supplied as a separate document attached to this one, plus an additional copy attached to the air heater.
- 6.3 These appliances must be earthed.
- 6.4 A separate electrical isolator for each heater must be provided adjacent to the appliance. The isolator must have a contact separation of at least 3.0 mm on all poles.
- 6.5 Ancillary controls are required to provide timed heat cycles, room comfort temperature level, frost protection, override air circulation etc. These are not included with the appliance and should be ordered separately.
- 6.6 Ensure when planning the external appliance control circuitry, that power will be supplied at all times to the air heater, even when it is control switched in the 'heat-off' mode. This is necessary to ensure that the fan can operate independent of the heating control. Therefore, **Never** incorporate automatic controls that electrically isolate the appliance.

**NOTE: EURO.T AIR HEATERS ARE SUPPLIED WITH EXTERNAL CONTROL CIRCUITS BRIDGED. THE AIR HEATER/S WILL OPERATE CONTINUOUSLY UNLESS THESE ARE REMOVED AND TIME AND TEMPERATURE CONTROLS SUBSTITUTED FOR THEM**

## SECTION 7. COMMISSIONING, LIGHTING AND OPERATION

### COMMISSIONING

7.1 Normally Reznor Euro-T air heaters do not require commissioning. Final testing after production ensures that: If installation has been carried out strictly in accordance with this document, the appliance is ready to be taken into service.

7.2 Checks to ensure;

- earth continuity
- resistance to earth
- phase supply to correct terminals
- current rating and fuse value
- correct supply gas pressure
- correct burner gas pressure
- satisfactory & smooth ignition
  - Flue system is evacuating the products of combustion to outdoor atmosphere.

must be made.

### 7.3 LIGHTING

- Ensure that air discharge louvres are set to open.
- Turn on gas supply.
- Switch on electrical supply.
- Set time switch (if fitted) to an 'ON' cycle.
- Set room thermostat to 'ON' position.
- If reset button on heater and/or on remote control (if fitted) glows, press reset button.
- Heater should now light automatically within 2 minutes. after a further period the air circulation fan should run, (see also below: "operation" point 6).
- For a new installation or if the appliance has been turned off for an extended period then up to 3 attempts to light the air heater may be necessary. If the heater still does not light, consult the fault finding guide section 9.

### 7.4 OPERATION

Refer to figure 11.

7.4.1 At the dictates of the external controls, an electrical circuit is made and the combustion air fan ("venter") runs.

7.4.2 Provided adequate air flow is proved, the fan will continue to run approximately 30 sec. (pre-purge period).

7.4.3 Euro-T air heaters employ the direct burner ignition principle. A hot surface igniter will glow for  $\pm 15$  seconds, after which time the gas valve(s) will open and the burner will be lit.

7.4.4 If the burner has not lit within 5 seconds, the electronic flame relay will switch off and lockout will occur. This will cause the signal lamp to glow within the reset push-button on the appliance and/or on a remote control if fitted). After 10 seconds the reset button on the appliance or the remote control can be activated in order to reset

and restart the appliance.

7.4.5 Flame failure protection is by the ionisation principle i.e. the ability of a suitable flame to pass an electrical current between the igniter and the earthed burner assembly. To check the flame current is adequate, remove jumper between terminal 17 and 18 on the automatic burner control, connect a DC micro ammeter between the terminals. Ionisation current should be  $\geq 2\mu\text{A}$ .

**Note:** The terminals carry mains voltage when energised.

7.4.6 Simultaneously to the ignition circuit and gas valve circuit being energised, electrical power is supplied to an anticipator within the air circulation thermal fan control. The air fan will start after about 2 minutes and warm air at a temperature of approximately  $40^{\circ}\text{C}$  is now discharged from the appliance.

7.4.7 In the event of the combustion air volume falling below a safe level, the burner will be extinguished a re-start cycle will commence after adequate combustion air volume has been restored.

7.4.8 If the burner flame is extinguished for any reason during a run cycle, an automatic attempt for re-ignition will take place, if the burner does not relight then safety shut down and lockout will occur. Manual intervention to reset is necessary to put the air heater back into service.

7.4.9 In the event of overheating for any reason, thermally activated fail safe overheat controls operate to switch off the burner. The first control (LC1) switches off the burner and upon its cooling, automatically resets and the lighting sequence starts automatically. The second control (LC3) which operates at a higher temperature setting, will switch off the burner and itself set to a lockout condition which also requires manual intervention to reset to restore the heater to operational condition. A cooling time of  $\pm 1$  minute is necessary before thermal re-setting can be carried out

7.4.10 When the set temperature or the heating time period has been reached, electrical power to the burner relay will be switched off and the burner will extinguish. The air fan will continue to run until the heat exchanger has been cooled down to a safe level.

7.4.11 To turn off the air heater for a short period,

- turn room thermostat to lowest setting.

To relight reset thermostat.

For prolonged period;

- a. turn room thermostat to low setting,
- b. turn gas supply to the appliance off.
- c. switch off electricity supply to the air heater after air circulation fan has stopped.

To relight follow lighting instructions.

- 7.4.12 The gas service tap must only be operated in emergencies, for servicing or prolonged periods of shutdown of the air heater.

## SECTION 8. MAINTENANCE

### 8.1 General

Before commencing servicing, turn off the main gas supply and switch off the main electricity supply after the air circulation fan has stopped.

- 8.2 It is recommended that maintenance is carried out at least once a year. More frequent servicing may be required dependent upon the environmental circumstances where the air heater is installed. Regular inspection is necessary, especially in dirty areas, to assess the servicing frequency.

- 8.3 Check condition and security of flue and combustion air system.

- 8.4 Check for security and worthiness of the suspension or mounting system.

- 8.5 To gain access to the controls and flue gas fan assembly.

- 8.5.1 For appliances fitted with vertical flue systems, refer to figure 7. Follow the four step procedure:

- 1. Unlatch cam fastener ¼ turn counter clockwise on controls compartment access panel.
- 2. Remove access panel.
- 3. Unscrew retaining screw at top of upper cover panel.
- 4. Upper panel can now be removed by pushing upwards 2 cm to disengage panel retaining lugs and then lifted away.
- 5. The flue installation should include a service access section adjacent to the connection socket allowing access to the top of the flue fan. In the event that the fan housing assembly requires removal i.e. for replacement, then it is necessary to remove that section to access the 4 securing screws that fasten the fan housing through the top of the appliance.  
All controls, electrical and flue gas components are now accessible.

- 8.5.2 For appliances fitted with horizontal flue systems: follow steps 1 & 2 above and then;

- 1. Disconnect flue and combustion air inlet pipes at the section provided. Ensure that the pipes will remain supported when disconnection has been made.
- 2. Remove 4 sheet metal screws securing the venter fan to the upper cover panel.
- 3. Follow steps 3 & 4 8.5.1 above.

- 8.5.3 To replace reverse order above as appropriate.

- 8.6 If it is necessary to remove the cabinet top panel to gain access to the flue products collector box or the top of the heat exchanger, it is necessary to:

- 1. Isolate and disconnect the electrical and external controls wiring that passes through the panel.
- 2. Isolate and disconnect the gas service to the air heater.
- 3. Remove all of the sheet metal screws that secure the top panel to the appliance and remove panel as required.

- 8.7 Remove all dust and dirt from the combustion air fan (venter) see fig. 9 If dismantling venter observe critical dimensions before reassembly.

- 8.8 Check that air circulating fan guard is undamaged and secure.

- 8.9 Check security of the fan blade and fan motor. **Note:** The fan motor is lubricated for life and does not require lubrication.

- 8.10 Inspect hot surface igniter fig.8 replace if in doubt about its condition. **Note: The Igniter device is fragile, therefore, handle carefully**

- 8.11 Inspect and clean the burner assembly, refer to fig.10

- 8.12 Inspect heat exchanger and clean as necessary. This can only be done after removing the burner assembly.

- 8.13 After removal of burner assembly, each element of the heat exchanger can be cleaned by use of a soft brush and compressed air. Clean both inside and the outside surfaces.

- 8.14 Clean burners and gas jets with soft brush and compressed air. To prevent damage, do not use hard objects for cleaning the gas injectors

- 8.15 If anchor lines of service panels are removed during servicing, they must be refitted upon completion of the service.

- 8.16 Upon completion of any service work it is necessary to recommission the appliance in accordance with the step procedure described in section 7.7.2 of this document.

Fig. 7 SERVICE ACCESS KEYS

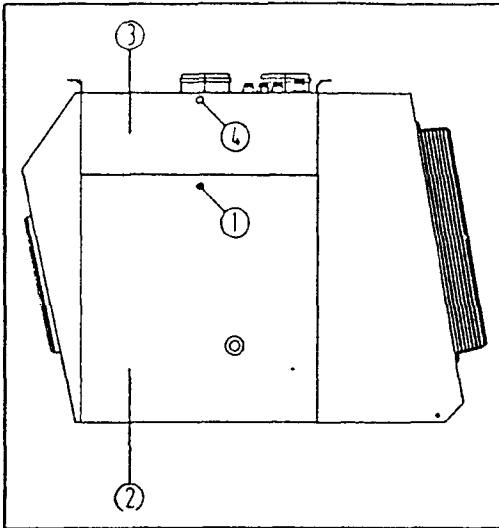

Fig.8 IGNITER ASSEMBLY

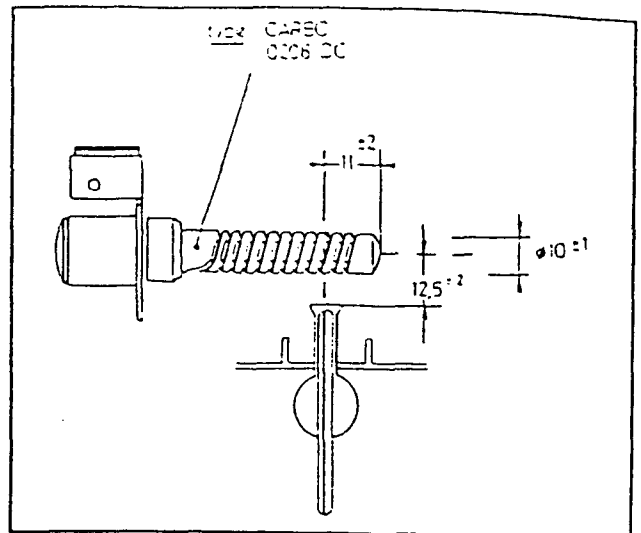
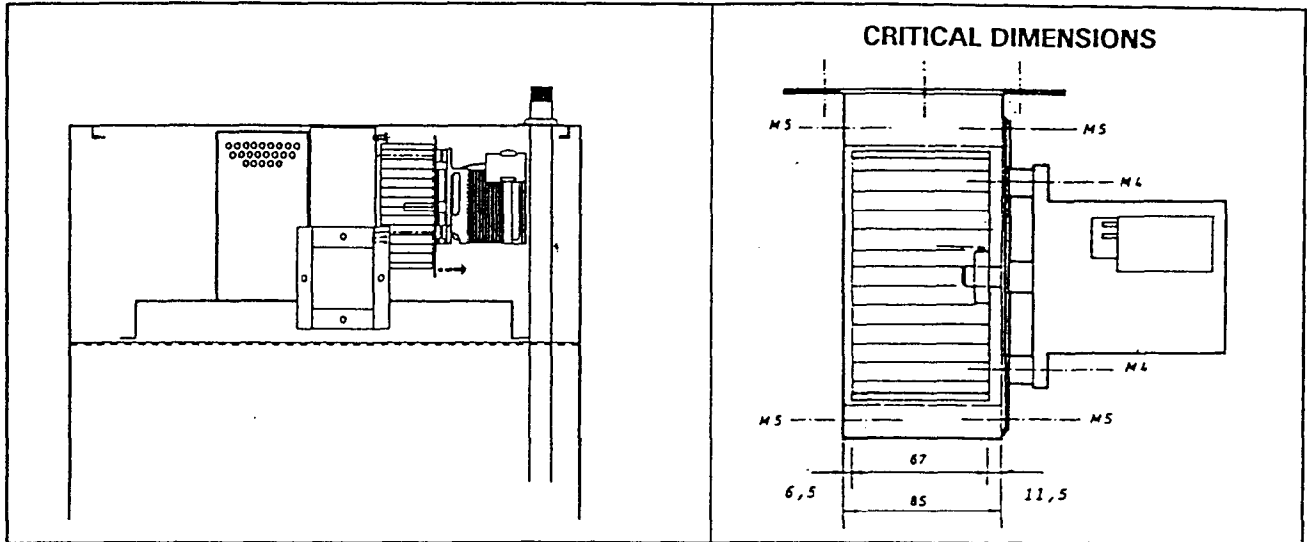

Fig. 9 REMOVAL OF COMBUSTION AIR FAN (VENTER) MOTOR FAN IMPELLER ASSEMBLY



**8.15 TO REMOVE COMBUSTION AIR FAN:**

1. Disconnect electrical connections to fan motor.
2. Remove motor and venter wheel (3 screws).
3. Withdraw motor/impeller assembly sideways.
4. Clean venter housing.
5. Check, clean or replace motor and/or venter wheel.
6. Replace in reversed order after checking critical dimensions (fig. 9)

Fig. 10 REMOVAL OF BURNER ASSEMBLY

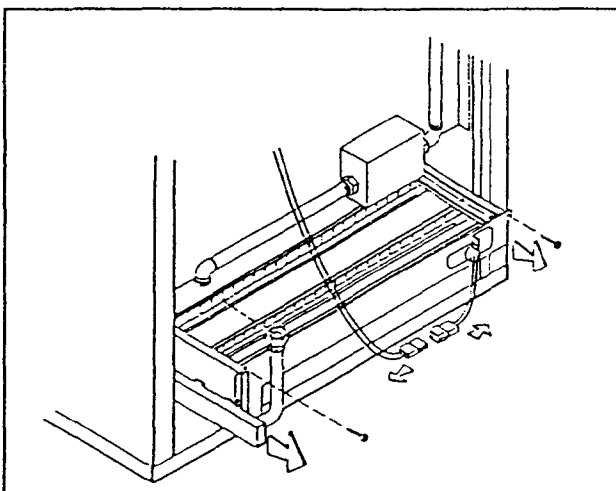

**TO REMOVE BURNER ASSEMBLY:**

1. Turn off the main gas supply.
2. Switch off the main electricity supply after air circulation fan has stopped.
3. Open service panel fig.7.
4. Disconnect wires of igniter.
5. Disconnect union fittings between gas valve(s) and burner.
6. Unscrew fixing screws of burner and pull forward burner assembly on it's slide rails.
7. Replace in reversed order

Figure. 11

COMPONENT PARTS LAY OUT

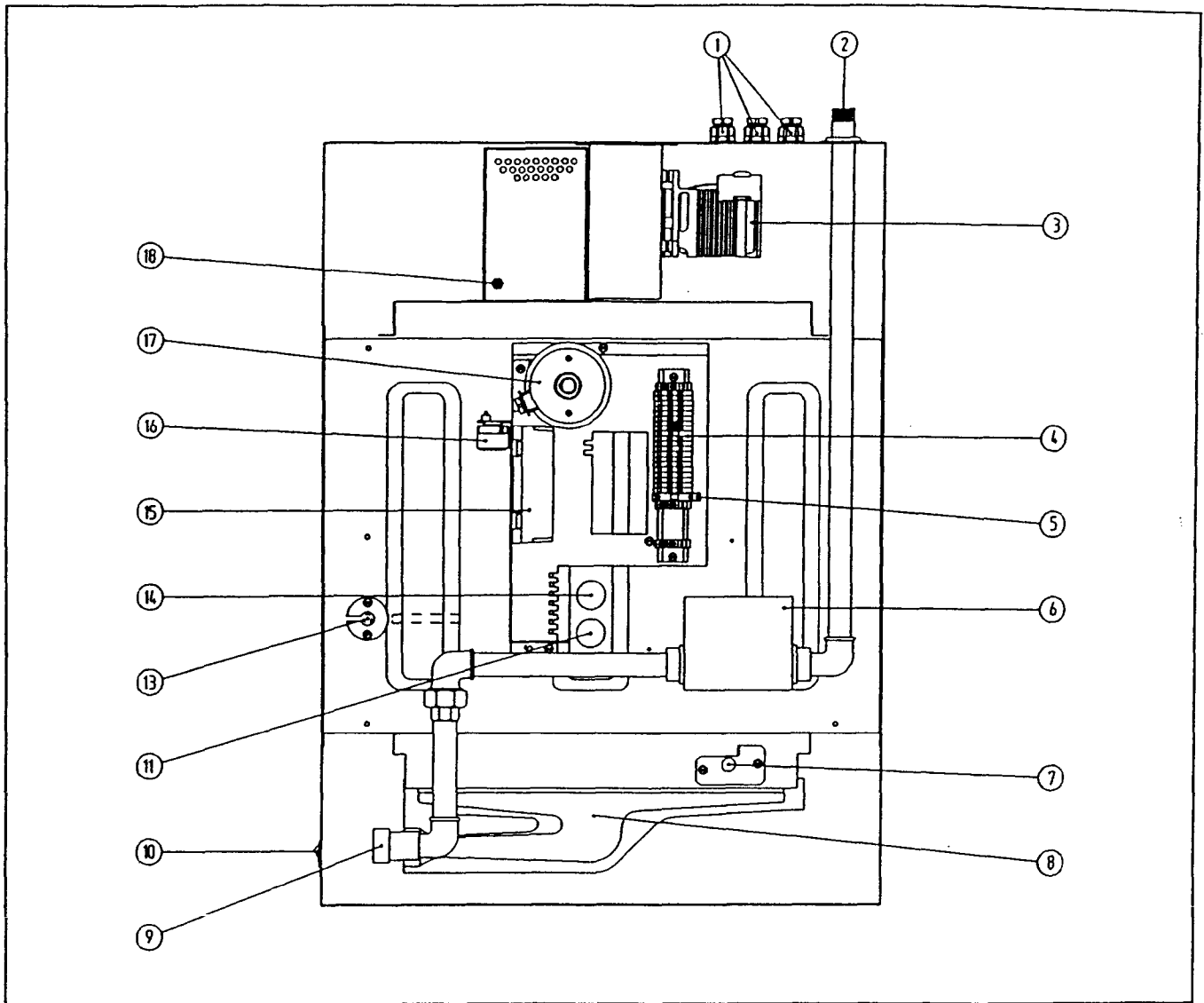

Legend:

- |  |   |
|--|---|
| 1. Cable entry all electrical connections      | 10. Reset button with indicator for burner relay lock-out |
| 2. Gas connection 3/4" (not supply line size)  | 11. Fan thermostat (FCR)                                  |
| 3. Combustion air fan with motor               | 12. Not used for UK!                                      |
| 4. Terminals for all electrical connections    | 13. Bulb of thermal overheat and seal/grip (LC3)          |
| 5. Fuse  | 14. Thermal overheat control (LC1)                        |
| 6. Double gas valve with pressure regulator    | 15. Burner relay  |
| 7. Hot surface igniter                         | 16. Thermal overheat control (LC3)                        |
| 8. Burner tray with burner ribbons             | 17. Differential switch                                   |
| 9. Manifold with injectors and pressure nipple | 18. Differential pressure reference point nipple          |

**THE APPLIANCE WILL ONLY OPERATE WITH ALL PANELS CORRECTLY FITTED !!**

## SECTION 9. FAULT FINDING

### 9.1 Burner does not ignite

- Thermostat set too low or time switch not correctly set; no power to terminals 2 and 5.
- Fuse F3 has blown; no power to terminal 2 and LC3.
- Reference tube to differential air pressure switch S3 is not airtight or blocked.
- Faulty differential air pressure switch S3; no power to terminals 2 and 13.
- Insufficient differential pressure in flue pipe system; Flue blocked or too long.
- Burner relay in lockout (point 2 below) or faulty.
- Faulty combustion air fan M3 (venter).
- Faulty limit control LC1; no power to terminal 2 and LC1.
- Overheat control LC3 in lockout; no power to terminal 2 and LC3; Reset manually.

### 9.2 Flame relay in lockout

- Air in gas service; purge.
- Low gas pressure.
- Faulty hot surface igniter.
- Faulty differential air pressure switch.
- Gas valve does not open; no power to terminals 2 and 7.
- Insufficient ionisation flame current; ionisation current  $\geq 2\mu\text{A}$ .
- Incorrect wiring of mains input line, neutral, earth.

### 9.3. Combustion air fan (venter) does not start

- Faulty motor or capacitor.
- Faulty burner relay.
- Differential air pressure switch S3 still in normal run position no change-over.
- Faulty fuse F3.

### 9.4 Differential air pressure switch switches burner off

- Switch-point should be; ON 0,99 mbar, OFF 0,94 mbar, type..35/36: ON 0,74 mbar, OFF 0,69 mbar.
- No differential pressure in flue gas system; check flue and air inlet.
- Faulty combustion air fan or capacitor.

### 9.5 Appliance does not provide sufficient warm air

- Check gas inlet pressure.
- Check burner pressure.
- Gas filter (if fitted) dirty or blocked.
- Limit control (LC1) switches burner off (see 9.6).
- Differential pressure switches relay off (see 9.4).

### 9.6 Limit control LC1 switches burner off

- Switch temperature 51,5°C, ..55/56....95/96 top connection: 63°C.
- Insufficient air flow.
- Vertical and horizontal louvres set in closed position.
- Burner overload, check burner and inlet gas pressure.
- Fan control switch faulty
- Check fan rotational direction.
- Air temperature at fan inlet too high; T max. 30°C (see 9.6).
- Thermal contact in fan motor switches off intermittently.

### 9.7 Limit control LC3 switches

- Switch temperature 96°C (+ 0/-5).
- Check location and security of capillary and probe.
- Air discharge temperature too high (see 9.6).
- Faulty limit control LC1.
- Air fan stops immediately after burner is switched off; incorrect control/s wiring.
- Faulty fan control (FC).

### 9.8 Air fan does not start

- No power to terminals 2 and 11.
- Faulty fan control (FC).
- Faulty motor or capacitor.
- Thermal over-load in motor switching.

### 9.9 Fan starts and stops intermittently while burner is on.

- Faulty heat anticipator (FCR) in fan switch.
- Thermal over-load in motor switching.
- Inlet ambient air temperature too low; T min.  $< 5^{\circ}\text{C}$ .; will correct as space temperature rises.
- Faulty wiring connection; loose terminals!

## SECTION 10. SPARE PARTS LIST

### 10.1 GAS SECTION

DESCRIPTION	PART NUMBER	MFGS.REF.	APPLICATION
Gas valve single stage burners	03 25250	SIT 830 Tandem	2..25/26 - 2..35/36
Gas valve single stage burners	03 25136	H'well VR4601AB	2..45/46 - 2..95/96
Gas valve two stage burners	03 35136	H'well VR4601BP	Two stage options

### 10.2 ELECTRICAL SECTION

DESCRIPTION	PART NUMBER	MFGS.REF.	APPLICATION
Thermal fan control	03 25166	TOD29T12 (250V)	All
Thermal over-heat control (limit) LC1	03 24970	TOD60T11	All
Thermal over-heat control LC3	03 24959	limit 96° C	All
Combustion fan motor	11 43426 01	Drouard-tec CP 78	All
Combustion circuit pressure switch	30 30612	Huba 604	Models <b>All EXCEPT</b> 2-35
Combustion circuit pressure switch	30 60612 35	Huba 604	Model: 2.35
Automatic burner control	03 25316	Honeywell S4570LS	All
Hot surface ignition device	05 25150	Carborundum	All
Two pole relay K1.2	30 61738 240V	Omron G7L2A	All two stage burners
Wiring harness for burner control	06 41531 HGC	----	All
Wiring connector for igniter device	06 41531 HGC	----	All
Wiring harness for two stage burners	06 41621	----	All
Wiring terminals	06 41635	Entrelec	All

### 10.3 AIR HANDLING SECTION

DESCRIPTION	PART NUMBER	MFGS. REF.	APPLICATION
Fan motor	01 26006 04	MAC35W4	2..25/26
Fan motor	01 26006 05	MAC50W4	2..30/31
Fan motor	01 26006 07	MXC60P6	2..35/36 & 2..45/46
Fan motor	01 26006 09	MXC70P6	2..55/56:
Fan motor	01 26006 12	MXC50L6	2..75/76
Fan motor	01 26006 16	MXC65L6	2..95/96
Axial fan	02 26008 04	S40/4PR23	2..25/26
Axial fan	02 26008 05	S40/4PR30	2..30/31
Axial fan	02 26008 07	S40/4PR17	2..35/36 & 2.45/46
Axial fan	02 26008 09	S60/3PR25	2..55/56
Axial fan	02 26008 12	S70/3PR17	2..75/76
Axial fan	02 26008 16	S70/4PR20	2..95/96

10.4 MISCELLANEOUS

DESCRIPTION	PART NUMBER	MFGS. REF.	APPLICATION
Combustion air fan impeller	02 25728	Punker	All
Suspension sockets 1" BSP (R1)	35 20003 2000	AI	Options
Sampling pressure test point	07 25811 02	M8	All
Silicon tubing	06 20224 cm	∅ 5-8 mm x 1.0 m	All
Combustion fan assembly gasket	11 44696	---	All
Capillary seal plate assembly	08 07727	---	All

**SECTION 11. GAS CONVERSION**

- 11.1 This air heater is designed to operate on natural, propane or butane gas and will be supplied as ordered for the gas type specified. In the event it is required to convert to a different gas type to that which has been supplied, conversion of the gas burner must be carried out.
- 11.2 A Reznor approved conversion kit to suit the appropriate gas type must be used.
- 11.3 In addition to changing the burner injectors, and adjusting the gas pressure, sealing a governor or fitting a blanking plate it is necessary to fix over stickers as supplied with the conversion kit of parts.
- 11.4 After conversion re-commission appliance according to section 7 of this document.

Figure. 12 BURNER AIR SHUTTER AND SETTING DIMENSION for all GASES UK & IE

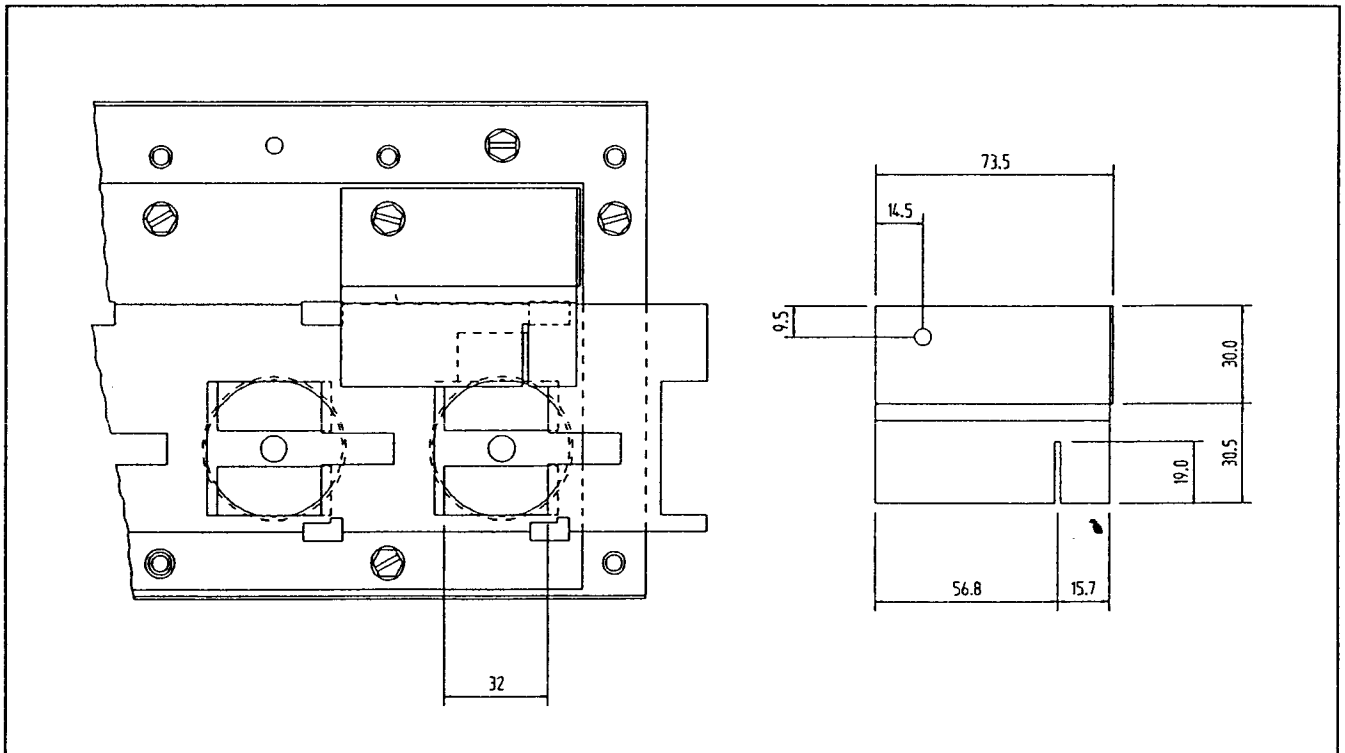



## SECTION 12. HEALTH & SAFETY STATEMENT

### Health and Safety Information for the Installer and Commissioning-Service Engineer

#### 12.1 General

Under the Consumer Protection Act 1987 and Section 6 of the Health and Safety at Work Act 1974 we hereby provide the following information on substances hazardous to health. Product range reference Euro.T Series air heaters.

#### 12.2 Cautionary note

During first firing some smoking may occur, this is due to the burning off of protective/lubricating oils used during appliance production. Most of this will have been removed during the production testing process. It is a wise precaution to ensure that adequate ventilation is provided during the initial firing and throughout the commissioning period, this is particularly important if the discharge air is to blow into a confined space. This smoking does not constitute a poison hazard.

#### 12.3 Declaration

Reznor products contain no asbestos; copper is not employed in gas carrying components; solder which has a melting point below 450°C is not used; paints for corrosion protection and decoration are heat cured and contain no lead.

#### 12.3.1 The above appliances meet the Electrical Safety requirements of EN60 335 Pt 1 1988.

#### 12.4 Miscellaneous

Small quantities of adhesives and sealants used in the product are dried and cured and present no known hazard.

#### 12.5 Insulation and Seals.

Material: Alumino - silicon fibre

Description: Tapes

Known hazards: Some people can suffer reddening and itching of the skin. Fibre entry into the eyes will cause foreign body irritation. Inhalation will cause irritation to the respiratory tract.

Precautions: Wear protective gloves when handling.

People with a history of skin complaints may be susceptible to irritation.

Dust levels are only likely when the material is abraded.

In general normal handling and use for this purpose will not present discomfort. Follow good hygiene practices, wash hands before consuming food or using the toilet.

First Aid: Medical attention must be sought following eye contact or prolonged reddening of

the skin.

#### 12.6 Thermostat.(Thermal overheat (limit) control LC3)

Material: Illuminating Kerosene.

Description: Sealed phial contains a small quantity in liquid form.

Recognition: Colourless liquid, paraffin oil/petroleum hydrocarbon odour.

Characteristics: Non-corrosive, flammable with no poisonous reference-CH poison Class 3

Precautions: Avoid handling. This product can irritate and defat the skin. Prolonged contact may cause dermatitis. Avoid breathing vapour. Avoid eye contact. Do not ingest.

First Aid: Skin. Wash thoroughly with soap and water.

Eyes. Rinse immediately with copious amounts of clean water.

Ingestion: Seek medical advice.

**NOTE:** If skin irritation persists seek medical advice.

#### 12.7 Electrolytic Capacitor

Two types are used by random selection:

Recognition: 1. Plastic enclosure 2. Aluminium enclosure

Material: Contained liquid electrolyte

Known hazards: Electric shock possible if charged.

Precautions: Discharge to ground/earth. Do not incinerate.

First Aid: Treat for electric shock if affected.

**END OF HEALTH AND SAFETY STATEMENT**

Reznor UK Ltd 01/95ejb

## SECTION 13. USER INSTRUCTIONS

### OPERATING

#### How the air heater works:

Gas is burned by an atmospheric burner which fires into a heat exchanger. The gas burner is controlled by a double gas valve via an electronic burner control, which is actuated automatically via external controls i.e. a room thermostat and/or a time switch. The burner is ignited by a hot surface igniter. When the burner fires and warms the heat exchanger, the heat is sensed by a thermally actuated fan control which switches on the fan when the air temperature has reached its preset operating level.

At the end of a heating cycle the burner is switched off, the air circulation fan will continue to run until the air heater has cooled to a safe condition. Thereafter the fan will remain off until the next cycle is initiated.

#### Safety:

1. Flame failure is detected by the hot surface igniter which is also the sensor and will, immediately result in gas valve shut down.
2. Safety against overheating is assured by two overheat controls. The first is an automatic recycle control which protects against low air flow i.e. clogged air ways, fan failure etc. The second, which is set to a higher level than the first one, is a control which locks out and switches off the burner in the event of gross overheating for any reason. Manual intervention is necessary to reset this control device. Resetting of the automatic burner control may also be required.
3. The location of the air heater should be maintained at normal atmospheric pressure. Changes to the building after air heater installation, should have regard to the heating installation, i.e. structural changes causing excessive draughts from doors, windows etc. Other air handlers and installation of air extraction equipment which may cause a negative pressure environment, can seriously affect the operation of this type of air heater, especially if combustion air supply is not ducted.

#### To light the heater:

1. Turn on the gas supply to the air heater.
2. Switch on the electricity supply to the air heater.
3. Ensure time switch (if fitted) is set to a 'ON' cycle.
4. Adjust control/room thermostat to desired temperature.
5. Air heater will light automatically when the room thermostat calls for heat.
6. If the appliance does not light:
  - a) check that the burner control does not require resetting. An indicator light glows at the front panel of the appliance and on a remote control if

fitted). Reset by pushing light/button on appliance or the remote control.

b) check if thermal overheat control requires resetting (see fig. 11 page 13 key 16).

7. If the thermal overheat control requires resetting and doing so restarts the air heater, wait until the appliance warms to thermal equilibrium, to ensure the overheat control does not lock out again. **If it does and the temperature near the heater is less than 30°C, then switch off the appliance and call for service.** If the temperature is over 30°C, take appropriate action to reduce the ambient temperature near the air heater.

#### Air circulation:

1. The space heating process is for air to be circulated through the appliance whereby it gains heat from a heat exchanger. The air is directly discharged into the space to be heated. The air is eventually recirculated. Therefore it is very important that an unobstructed path for the circulation of the air will be maintained. This is particularly important if the air heater has been installed to blow through the wall between two rooms.
2. Sometimes the air circulation fan of the appliance is connected to a remote over-ride switch. This enables cool air to be used for circulation purposes when the air heater is not used for heating purposes e.g. in summer.  
To use this feature:
  - a) switch ON electricity
  - b) switch ON manual override switch, this may be fitted as a feature on a remote composite control.

#### Maintenance:

1. Maintenance and service must only be carried out by appropriately qualified persons e.g. "Corgi" registered undertakings.
2. It is in your interest to ensure proper service and maintenance is carried out at a regular basis. Periods between service are dependent upon the local environment where the heater is installed. All gas appliances should be serviced at least once a year.
3. In case of any damage to the appliance, it must be shut down completely and checked by an appropriately qualified person.
4. In the event of difficulties in resolving any of these matters, please do not hesitate to contact Reznor or their official distributor.

**This page is intentionally blank**

# Reznor<sup>®</sup>

## REMOTE CONTROL PANELS

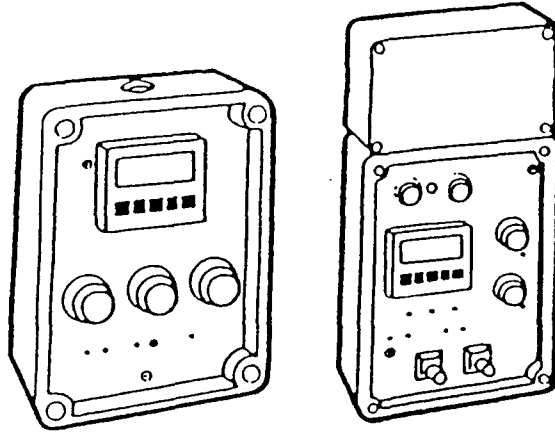

Economical Air Heating Controls to provide  
Environmental Comfort and Save Fuel

**Reznor Europe** J. & M. Sabbestraat 130 - 8930 Menen - België Tel: (056) 52 95 11 Fax: (056) 52 95 33

**Reznor Lufttechnik** Sontraerstrasse 18 - Frankfurt 60 - Deutschland  
Tel: (069) 401001-0 Tlx: 413845 Fax: (069) 401001-10

**Reznor Nederland** Mickeihorst 5 - 7961 DC Ruinerwold - Nederland  
Tel: 05222 2214 Fax: 05222 2562

**Reznor France** Av. Le Verrier - ZAI. les Bruyères - 78190 Trappes - France  
Tél: (1) 30667092 Fax: (1) 30508606

**Reznor Suomi** Kirkkullantie - SF-02400 Kirkkonummi - Suomi Finland  
Tel: (90) 2963191 Fax: (90) 2963193

Reznor is a ISO 9001/EN 29001 Registered Firm of Assessed Capability

**Other Products**  
Gas fired unit heaters.  
Infra-red plaque heaters.  
Radiant tube heaters.  
Direct fired make-up air heaters.  
Floor standing heaters.  
Roof mounted heating/cooling units.  
Water Heating Products.

**Remarks:**  
Use of this product in corrosive or inflammable atmosphere is not recommended. Warranty is void if unit is operated in presence of chlorinated vapours.  
**Models and Data:**  
Subject to modification without prior notice.

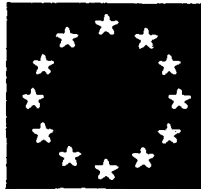

**Reznor UK Ltd**  
Park Farm Road  
Folkestone Kent  
England CT19 5DR  
Telephone: (0303) 259141  
Fax: (0303) 850002  
Registered in England No. 2426941

**Reznor**

A subsidiary of  
**Bullough plc**

No freedom to use industrial property rights, without copyright, is implied by the publication of this document.