

GAS FIRED AIR HEATERS TYPE EURO-H 30000 S

Axial Fanned, Forced Convection, Condensing High Efficiency Appliances with Automatic Ignition and Fanned Flues for use as:
Type B22 - C12 - C32

INSTALLATION COMMISSIONING SERVICING & USER INSTRUCTIONS

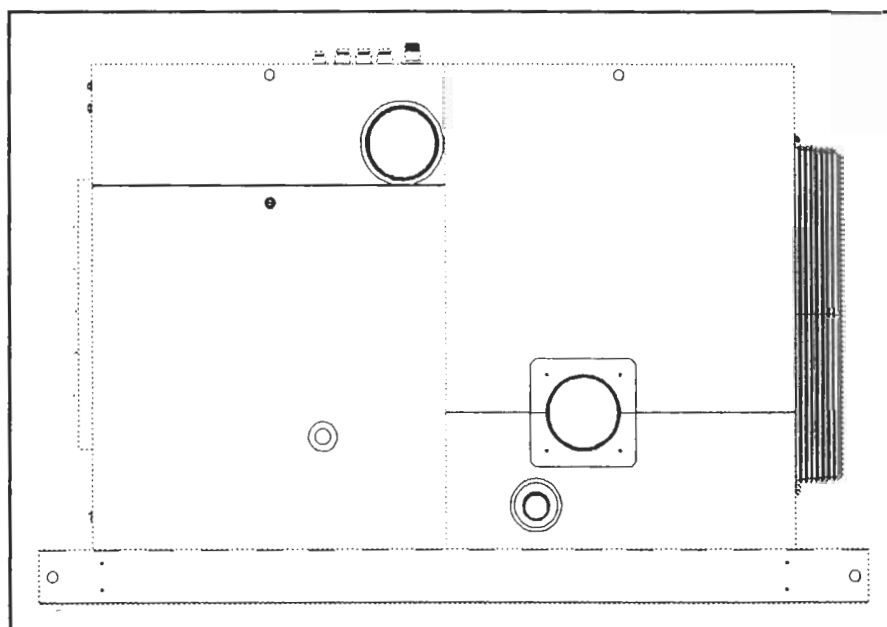

These appliances meet the following EC Directives:

Dir. CE 90/396/EEC: GAD

Dir. CE 89/336/EEC: EMC

Dir. CE 89/392/EEC: MD

Dir. CE 73/ 23/EEC: LVD

PLEASE READ THIS DOCUMENT CAREFULLY BEFORE COMMENCING INSTALLATION AND LEAVE IT WITH THE USER OR ATTACHED TO THE APPLIANCE OR GAS SERVICE AFTER INSTALLATION.

INDEX

	<u>Page</u>
1. General	2
2. Technical data	3
3. Installing	5
4. Combustion, Air supply and flue system	7
5. Gas connection	10
6. Electrical connection	11
7. Commissioning, lighting and operation	12
8. Maintenance	13
9. Fault finding	17
10. Spare parts list	18
11. Gas conversion	19
12. Health and Safety Statement	20
13. User instructions	21

If optional equipment was ordered and supplied with this air heater, please refer to additional instructions for option(s).

SECTION 1. GENERAL

- 1.1 Before installation, check that the appliance as described on the packaging label is in accordance with the correct type and model as specified on the data plate and complies with your customer order.
- 1.2 After unpacking the appliance, leave it fastened to any base packing for transportation until it has been suspended or until just before base mounting. This affords protection to the underside which is normally exposed to view after installation.
- 1.3 Please read this document before commencing installation.
- 1.4 These instructions are only valid for the country of use indicated on the appliance i.e. GB - IE. If these symbols are not shown, it is necessary to obtain appropriate technical instructions which will provide information concerning the necessary modification of the appliance for the conditions of use in the country concerned. Such instructions may be obtained upon request from your supplier.
- 1.5 Check that the local distribution conditions of electricity supply, type of gas and pressure, and adjustment of the appliance are compatible.
- 1.6 When installed in Great Britain the total installation must comply with the requirements and recommendations of British Standard BS 6230 1991. "Installation of Gas Fired Forced Convection Air Heaters for Commercial and Industrial Space Heating".
The Installation must also be in accordance with the relevant requirements of "The Gas Safety (Installation and Use regulations) and (Amendment Regulations 1990)" and The "Building" and "Electrical Regulations" (in GB the IEE Regulations).
The requirements of the "Local Building Standards Office", the local water services department responsible for the disposal of effluent, the premises "Insurance" undertaking and the "Fire Office" must also be observed.
- 1.7 Unauthorized modification of this appliance or departure from use in the manner for which it was intended by the manufacturer or installation in a manner contrary to these instructions, may constitute a hazard and jeopardize all warranties. Deviations may only be carried out after formal consent has been obtained from the manufacturer.
- 1.8 Ensure the environment in which the air heater will be installed will not create a hazard i.e. where excessive (volatile) dust, flammable or corrosive substances and/or vapours and combustible materials may be present.
- 1.9 This appliance has been tested, and set according to the data plate before leaving the factory.

SECTION 2. TECHNICAL DATA

Table 1. Appliance Data

Standard model Type EURO-H 30000 S			30067 S	30087 S	30107 S
Model with Low NO _x option EURO-H 35000 S			35067 S	35087 S	35107 S
Gas category 'Cat.'			H ₂ H ₃ +		
Air supply and flue type			B22 - C12 - C32		
Heat input (Hs) 'Qn'	kW		64,4	89,1	115,5
Heat input (Hi) 'Qn'	kW		58,0	80,2	104,0
High heat output	kW		60,0	83,0	107,0
Number of jets			9	12	16
Jet size	natural gas	ø mm	2,4		
	propane/butane	ø mm	1,35		
Gas supply pressure 'P' ¹	natural gas	mbar	17,5 GB - 20,0 IE		
	propane	mbar	37		
	butane	mbar	28		
Burner pressure ²	natural gas	mbar	8,50	9,30	8,80
Gas consumption	natural gas ³	m ³ /h	6,15	8,50	11,02
	propane	kg/h	4,60	6,36	8,25
	butane	kg/h	4,70	6,50	8,43
Gas service connection (not supply line size)			Rc ¾		
Temperature rise ΔT (± 1)	K		31	34	33
Air volume ⁴	m ³ /h		5640	7130	9610
Throw (terminal V ₀ = 0,5 m/s)	m		34,1	44,4	49,8
Nominal fan speed	rpm		1000		
Sound pressure level L _p ⁵	dB(A)		57	57	58
Electrical supply			230/240 1N ~ 50 Hz		
Protection grade			IP 20		
Fan motor rating	kW		0,40	0,37	0,56
*Total electric rating ⁶	kW		0,51	0,48	0,67
Volume of condensation produced to be drained (max)	ltrs/h		3,5	4,0	6,0
Appliance weight net	kg		187	228	290
Appliance weight gross (shipping)	± kg		217	263	330

1 Maximum gas pressure at inlet to appliance = 50,0 mbar

2 All casing panels fitted, service door open

3 Natural gas G20, calorific heating value 10,48 kWh/m³ on Hs @ 15°C & 1013 mbar
Propane G31, calorific heating value 14,0 kWh/kg. Butane G30, calorific heating value 13,7 kWh/kg

4 Isothermic condition (20 °C)

5 At 5,0 metres, Q = 2, A = 160 m², louvres no deflection, isothermic condition,

6 Total electrical rating during the start-up period ± 30 seconds is increased by 130 W and is not included on the appliance data plate or in the above table

Figure 1.

DIMENSIONS

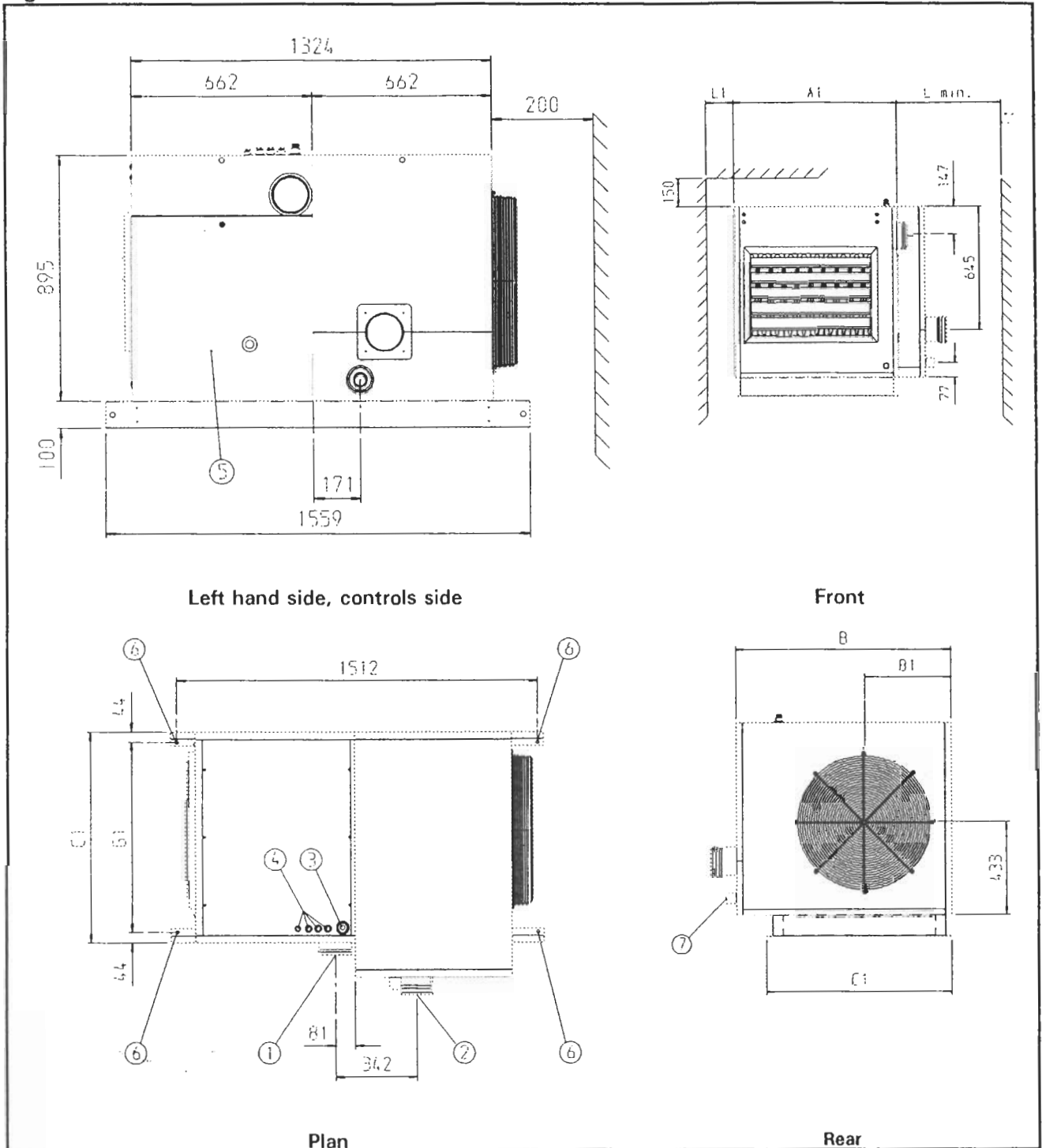

Legend figure 1.

- | | |
|---------------------------------|--|
| 1. Combustion air intake socket | 5. Burner and controls access panel |
| 2. Flue outlet socket | 6. Suspension points \varnothing 13 mm |
| 3. Inlet gas service connection | 7. Condensation drain connection |
| 4. Electrical & controls inlets | |

Table 2

Dimensions of dimensions reference fig. 1

Models	30067 S	30087 S	30107 S
	35067 S	35087 S	35107 S
Dimensions mm			
A1 Width of heating section	870	1080	1360
B Width of fan cabinet	1013	1223	1503
B1 Centre of fan to opposite side	405	510	650
C1 Width overall of base frame	874	1084	1364
G1 Width of suspension points	786	996	1276
L1 Opposite side clearance	150	300	300
L Minimum service clearance	900	1100	1400
Condensation drain	ø 1 ½" ID (41 mm OD)		
Flue & Combustion air socket ø internal	132		

SECTION 3 INSTALLING

- 3.1 **IMPORTANT** Reznor EURO-H 30000 series air heaters are high efficiency appliances designed to extract part of the latent heat from the products of combustion. The condensation so formed is collected within the appliance and directed to a drainage point from which it must be piped away as part of the installation see figure 8. Provision for connection to standard sanitary plumbing materials has been made, nominal size 1 ½" (40 mm) diameter. The approximate volume of condensation for drainage purposes is given in table 1.
- It should be noted that the products of combustion will be acidic. The level of concentration dependant upon the environment where the appliance is installed and may be as high as PH 3,0
- Copper or copper based alloys must not be used for condensate drains.**
- 3.2 Figure 2 shows the clearances necessary to ensure safety from combustibles and for service access.
- 3.3 Ensure that the structural elements which will be used to suspend or support the appliance, are adequate to carry the weight of the appliance and its ancillary components i.e. flue system.
- 3.4 The location where the air heater is to be installed, must provide sufficient space around the heater for servicing and clearances for safety see figure 4.
- 3.5 Ensure that the air heater is installed in a level plain.
- 3.6 Base mounting is optional. The air heater must be fastened securely to any base mounting arrangement.
- 3.7 4 suspension points with holes ø 13 mm are provided in the base frame of the appliance.
- 3.8 After suspension, the air heater should be rigid so as to avoid placing a strain on the flue system, condensate drain, gas services and electrical wiring.
- 3.9 Figure 3 shows methods to be avoided when mechanically handling the appliances. Please observe these guidelines.

Figure 2

CLEARANCES SUSPENSION & MOUNTING

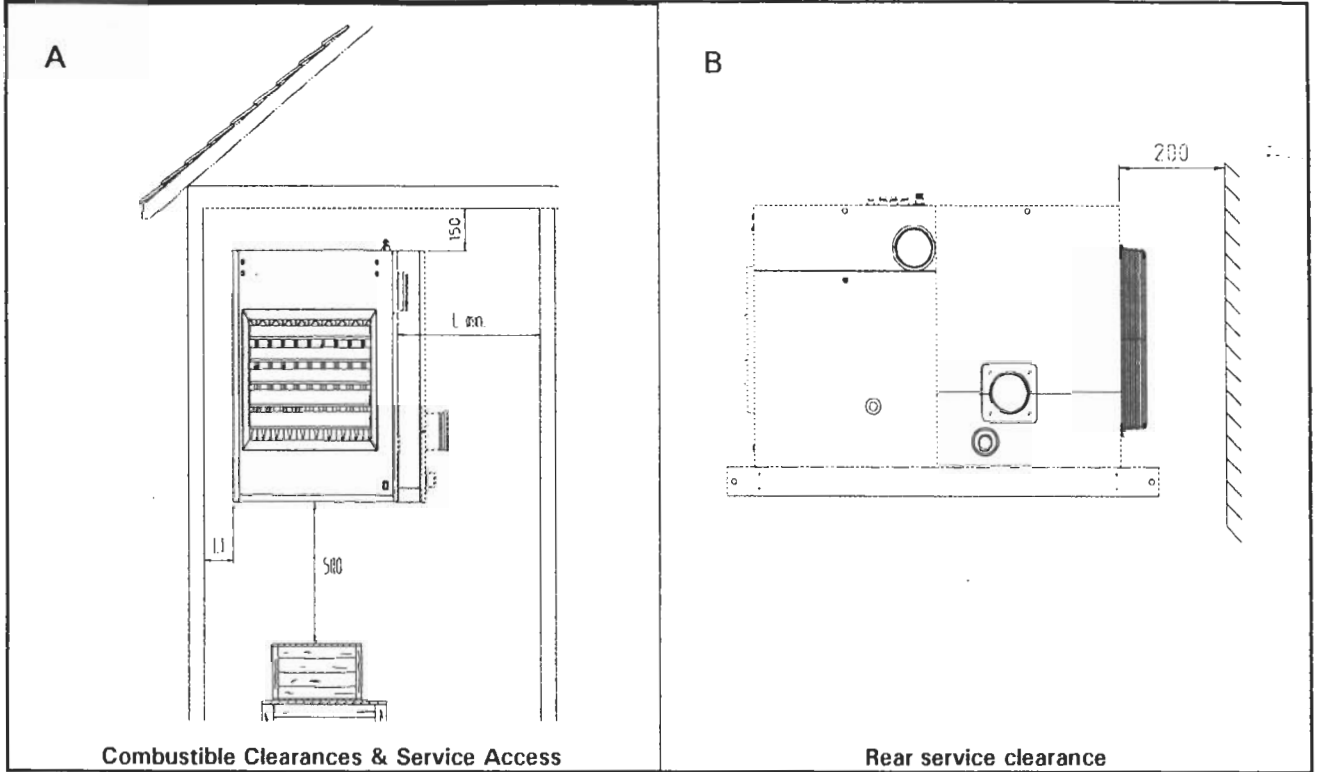

Table 3.

DIMENSIONS Re: FIGURE 3 A

Model	30067 S	30087 S	30107 S
Dimensions	35067 S	35087 S	35107 S
L minimum	900	1100	1400
L1 Opposite side	150	300	300

Figure 3

TRANSPORTING AND HANDLING THE EURO-H 30000 S AIR HEATER

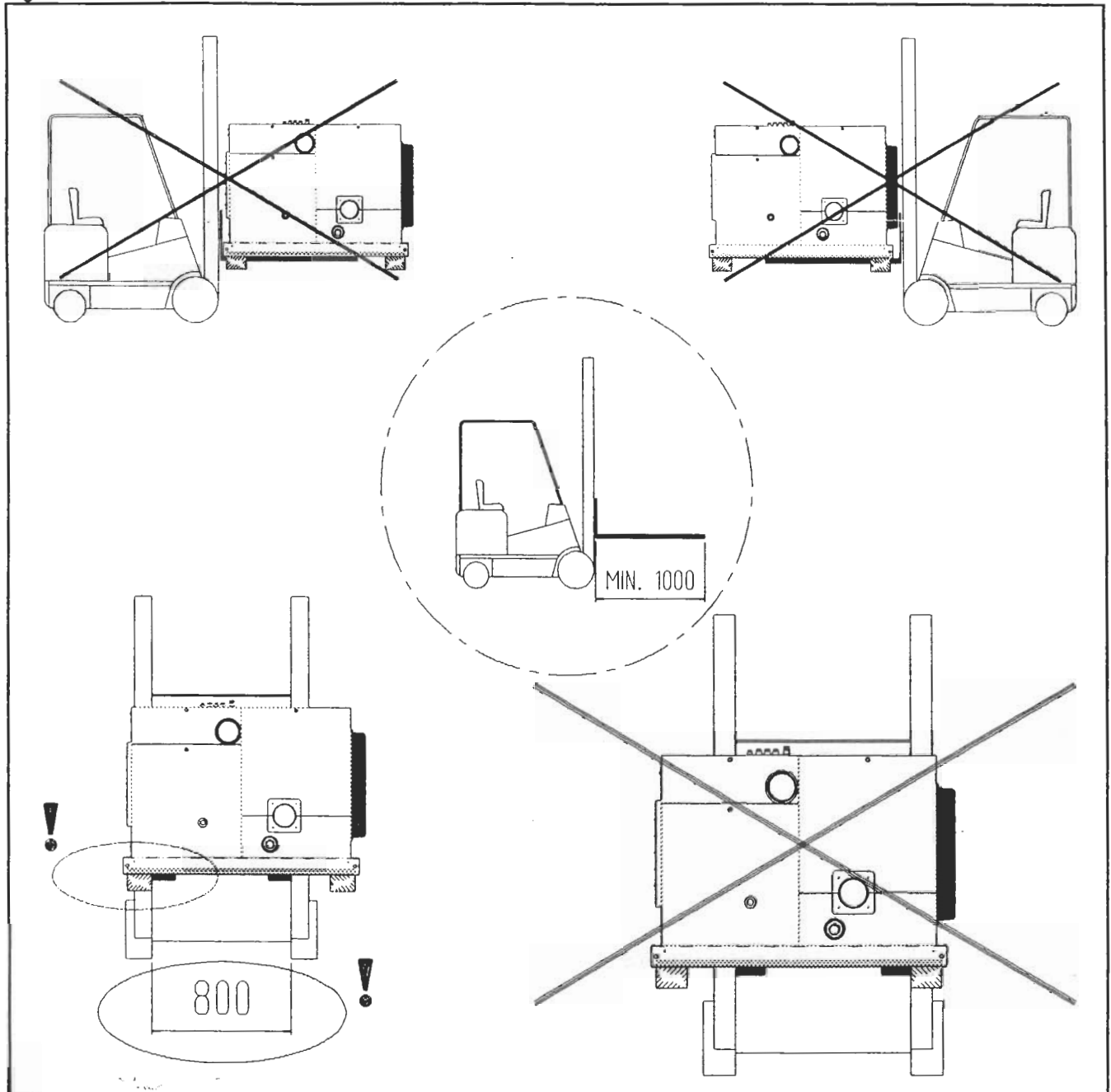

SECTION 4. COMBUSTION AIR SUPPLY AND FLUE SYSTEM

- 4.1 Flue systems must comply with national and local regulations.
- 4.2 The products of combustion must be flued to outdoor atmosphere. Common flues for more than one appliance must **NOT** be used. It is important to remember that the flue products from condensing air heaters are heavily laden with moisture. Pluming occurs at the terminal point.
- 4.3 Combustion air should be taken from out-door atmosphere, this improves the operational efficiency

of the heating system.

- 4.4 Flues where connected to the air heater must incorporate a disconnect section adjacent to the appliance to facilitate removal of the venter assembly for servicing. The flue system must therefore, be supported independently.
- 4.5 Dimensions and allowances in suggested flueing and combustion air intake arrangements are based upon the use of smooth wall heavy gauge aluminium flue and combustion air ducts and fittings.

- 4.6 **IMPORTANT:** The products of combustion from EURO-H 30000 series air heaters are laden with moisture some of which will condense out within the flue. Flues therefore, must be constructed from materials that can be installed without water leakage occurring. Reznor can supply seamless plastic gasket jointed heavy duty flue systems.

Horizontal flue runs must rise away 1° (17 mm per metre) from the appliance to ensure that the condensation water returns to the appliance internal drain.

Heavy gauge aluminium flue pipes are recommended for use with condensing gas appliances.

4.7 **Type C Appliances**

- 4.7.1 When using a concentric termination arrangement as figure 4 and 4A, then only an approved system using Reznor specified components may be used. These items are manufactured from seamless aluminium with connection sockets fitted with silicone double edged seals, thus assuring, if the components are undamaged, leak free flue systems. **Important:** This type of flue/combustion air intake system is regarded as an integral part of the air heater therefore, departure from this method of flueing is in breach of the EC Gas Appliance Directive.

- 4.7.2 Distance between the appliance and the concentric flue termination must not be greater than 10.0 m.

When calculating the total length the following equivalent data must be taken into account:

1 elbow @ 45° = 1 m.

1 elbow @ 90° = 1,5 m.

4.8 **Type B Appliances**

- 4.8.1 If the air heater is to be installed as a B type appliance i.e. air for combustion to be taken from within the space to be heated, as figure 5 then it must be ensured that an adequate air supply for combustion and ventilation is provided within the building, in accordance with the regulations and rules in force.

- 4.8.2 A horizontal distance between air heater and flue terminal and any combustion air intake duct, must not be in excess of 16 m.

Note: 2 Metres of vertical rise negates the resistance imposed by 1 meter of horizontal run. Runs exceeding 16 m may be subject to condensation forming within the flue.

Equivalent lengths of flue fittings:

Elbow @ 45° = 1 m.

Elbow @ 90° = 1,5 m.

Typical flue terminal ≤ 3.0 m.

- 4.8.3 To ensure that the allowable resistance is not exceeded and water drainage is ensured in the case of horizontal runs of flues, a positive rise from the air heater of 1° i.e. 17 mm per metre is recommended.

- 4.8.4 Flue terminals from condensing gas appliances are prone to icing in cold conditions. The location of flue terminals should take into account the possible hazard of icicles forming and dropping from the flue terminal.

- 4.8.5 The terminal of a vertical flue must extend 1 m above a roof surface, flues must not terminate where combustion products might enter the building. Terminals must be fitted to flues and combustion air inlets.

NOTE: The combustion air inlet on the air heater, if not used must be protected with an appropriate access guard.

- 4.8.5 Where type B installations are installed where mechanical building ventilation is used, it shall be by mechanical inlet with either mechanical or natural extraction. Automatic means of control such as electrical interlocks must be provided. The function of other ventilation systems in the heated zone must be taken into account. At no time should a negative pressure environment exist in the zone where the appliance is installed, this can lead to a hazardous situation, whereby the air heater flue may act as a pressure relief.

FLUE AND COMBUSTION AIR INTAKE ARRANGEMENTS

Figure 4. TYPE C APPLIANCES

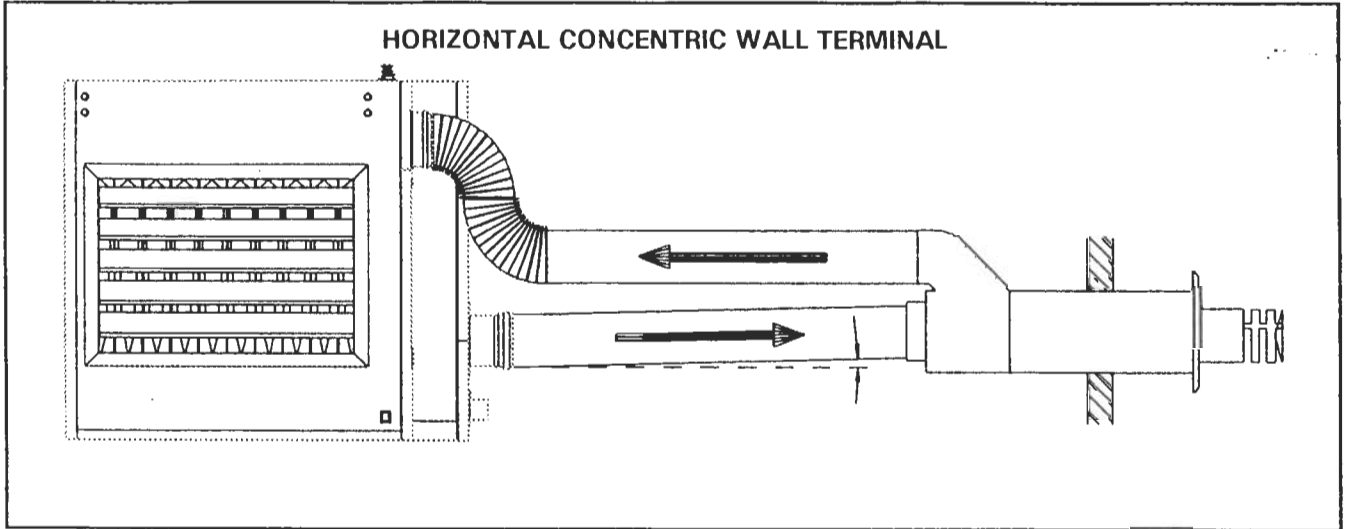

Mugro type 2000 or Burfix type 130 systems must be used on type C appliances (not icicle free)

Figure 4A. TYPE C APPLIANCES

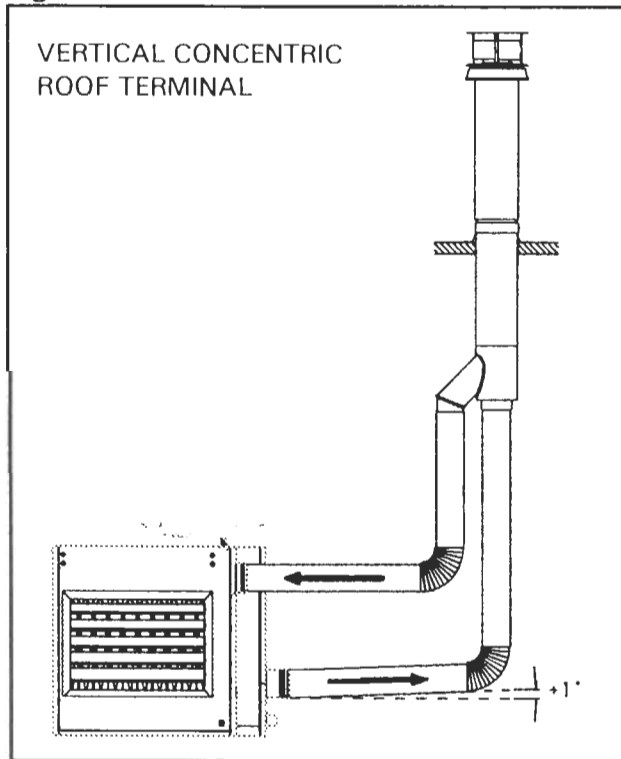

Recommended: Mugro type 3000 \varnothing 130 mm icicle free
 Alternative: Mugro type 2000 \varnothing 130 mm not icicle free
 or Burfix type 130 not icicle free

Figure 5. TYPE B APPLIANCES

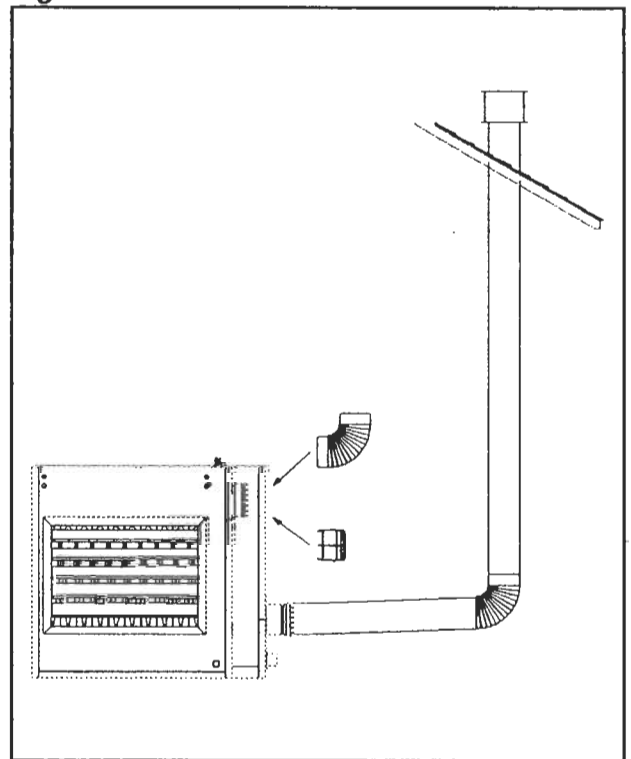

NOTE: If combustion air intake duct is not fitted inlet socket must have a protection guard as shown. Icicle free terminals are available upon request

Figure 6.

CONDENSATION DRAINAGE DETAILS

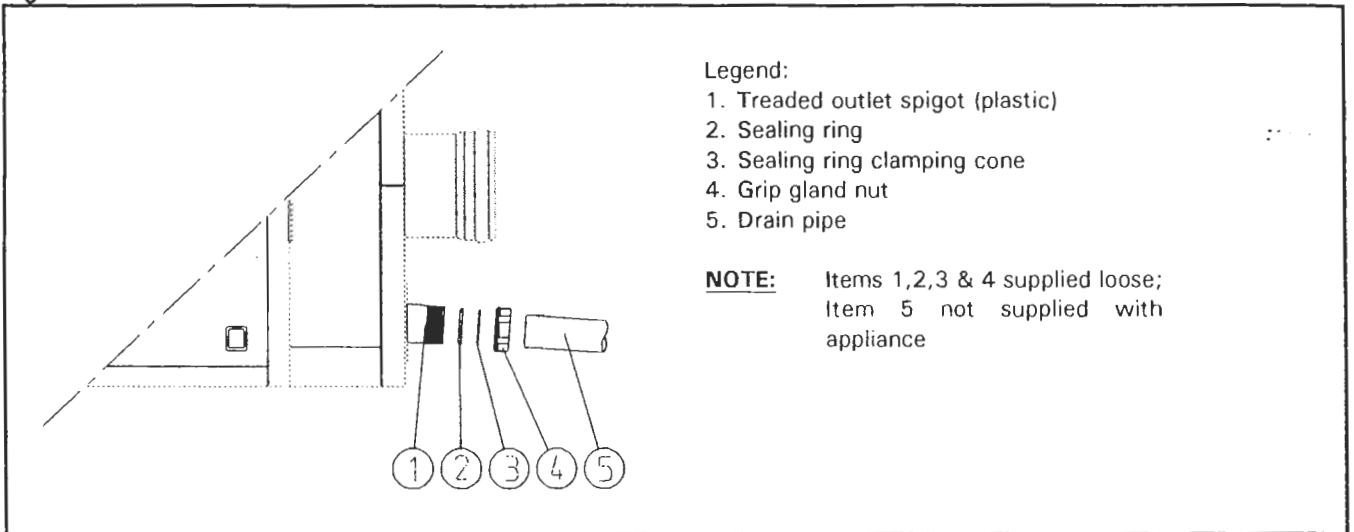

SECTION 5. GAS CONNECTION

- 5.1 Connection to a gas service may only be carried by suitably qualified persons. The gas installation must comply with the rules in force using materials appropriate for gas service installations.
- 5.2 Check that the gas category is in accordance with the data described on the air heater.
- 5.3 An adequate gas supply sized to provide the dynamic pressure for the volume required by the air heater(s) is essential to maintain the nominal heat input.
- 5.4 A 90° action gas service tap and, to facilitate servicing, a disconnect union fitting must be provided adjacent to the appliance, see fig. 7.
- 5.5 Ensure that a gas service includes a filter and has been tested and purged in accordance with prescribed practice prior to commissioning and taking the air heater into service.

Fig. 7 GAS CONNECTION DETAIL

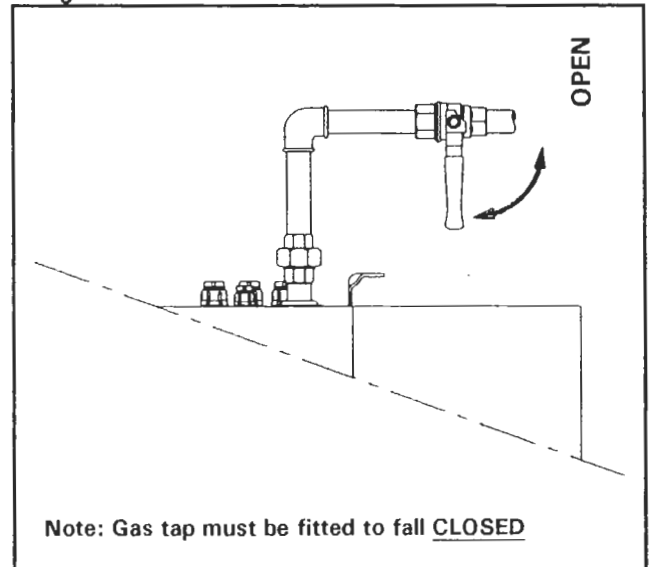

WARNING: NEVER use a FLAME to test for GAS Soundness !!!

SECTION 6. ELECTRICAL CONNECTION

- 6.1 The Electrical installation may only be carried out by suitably qualified persons observing the rules in force.
- 6.2 Check that the electrical specification is in accordance with the specified data on the air heater. A unique appliance wiring diagram is supplied as a separate document attached to this one, plus an additional copy attached to the air heater.
- 6.3 These appliances must be earthed.
- 6.4 A separate key lockable electrical isolator for each heater must be provided adjacent to and within site of any person working on the appliance. The isolator must have a contact separation of at least 3.0 mm on all poles.
- 6.5 Ancillary controls are required to provide timed heat cycles, room comfort temperature level, frost protection, override air circulation etc. These are not included with the appliance and should be ordered separately.
- 6.6 Ensure when planning the external appliance control circuitry, that power will be supplied at all times to the air heater, even when it is control switched in the 'heat-off' mode. This is necessary to ensure that the fan can operate independent of the heating control. Therefore, Never incorporate automatic controls that electrically isolate the appliance.

NOTE: EURO-H AIR HEATERS ARE SUPPLIED WITH EXTERNAL CONTROL CIRCUITS BRIDGED. THE AIR HEATERS WILL OPERATE CONTINUOUSLY UNLESS THESE ARE REMOVED AND TIME AND TEMPERATURE CONTROLS SUBSTITUTED FOR THEM

SECTION 7. COMMISSIONING, LIGHTING AND OPERATION

COMMISSIONING

- 7.1 Normally Reznor EURO-H air heaters do not require commissioning. Final testing after production ensures that: If installation has been carried out strictly in accordance with this document, the appliance is ready to be taken into service.
- 7.2 Checks to ensure;
- earth continuity
 - resistance to earth
 - phase supply to correct terminals
 - current rating and fuse value
 - correct supply gas pressure
 - correct burner gas pressure
 - satisfactory & smooth ignition
 - flue system is evacuating the products of combustion to outdoor atmosphere and are leak free
 - that the condensation drain works satisfactorily must be made.
- 7.3 Before commencing commissioning it is necessary to make the drain system airtight. A "bubble pot" in the form of a drain trap is provided for this purpose, this must be filled with water before start-up of the burner.

To fill the trap; disconnect the flue at the appliance flue outlet connection and pour a minimum of 2 litres of clean water into the flue connection socket, see figure 8, re-connect the flue.

NOTE: The above action serves also to verify the worthiness of the condensate drain system.

FIGURE 8. FILLING THE CONDENSATE DRAIN CIRCUIT

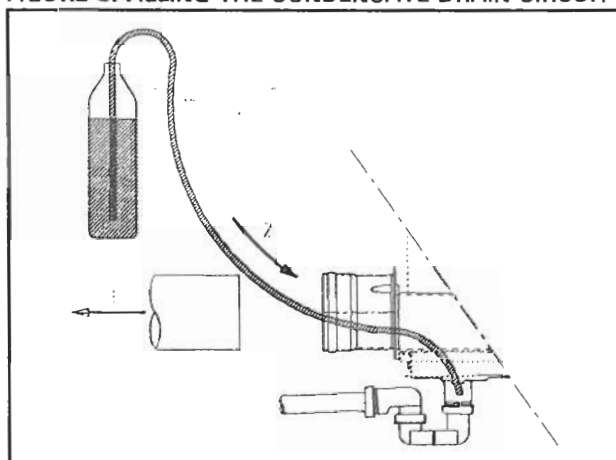

Legend figure 7.

1. Disconnect flue pipe
2. Fill drain trap with clean water

7.4 LIGHTING

- Ensure that air discharge louvres are set to open.
- Turn on gas supply.
- Switch on electrical supply.
- Set time switch (if fitted) to an 'ON' cycle.
- Set room thermostat to 'ON' position.
- If reset button on heater and/or on remote control (if fitted) glows, press reset button.
- Heater should now light automatically within 2 minutes. after a further period the air circulation fan should run, (see also below: "operation" point 6).
- For a new installation or if the appliance has been turned off for an extended period then up to 3 attempts to light the air heater may be necessary. If the heater still does not light, consult the fault finding guide section 9.

7.5 OPERATION Refer to figure 12

- 7.5.1 At the dictates of the external controls, an electrical circuit is made and the combustion air fan ("venter") runs.
- 7.5.2 Provided adequate combustion air flow is proved, the fan will continue to run approximately 30 sec. (pre-purge period).
- 7.5.3 Euro-H air heaters employ the direct burner ignition principle. A hot surface igniter will glow for ± 15 seconds, after which time the gas valve(s) will open and the burner will be lit.
- 7.5.4 If the burner has not lit within 5 seconds, the electronic flame relay will switch off and lockout will occur. This will cause the signal lamp to glow within the reset push-button on the appliance and/or on a remote control (if fitted). After 10 seconds the reset button on the appliance or the remote control can be activated in order to reset and restart the appliance.
- 7.5.5 Flame failure protection is by the ionisation principle i.e. the ability of a suitable flame to pass an electrical current between the igniter and the earthed burner assembly. To check the flame current is adequate, remove jumper between terminal 17 and 18 on the automatic burner control, connect a DC micro ammeter between the terminals. Ionisation current should be $\geq 2\mu\text{A}$.
- Note:** The terminals carry mains voltage when energised.
- 7.5.6 Simultaneously to the ignition circuit and gas valve circuit being energised, electrical power is supplied to an anticipator within the air circulation thermal fan control. The air fan will start after about 2 minutes and warm air at a temperature of

approximately 40°C is now discharged from the appliance.

- 7.5.7 In the event of the combustion air volume falling below a safe level, the burner will be extinguished a re-start cycle will commence after adequate combustion air volume has been restored.
- 7.5.8 If the burner flame is extinguished for any reason during a run cycle, an automatic attempt for re-ignition will take place, if the burner does not relight then safety shut down and lockout will occur. Manual intervention to reset is necessary to put the air heater back into service.
- 7.5.9 In the event of overheating for any reason, thermally activated fail safe overheat controls operate to switch off the burner. The first control (LC1) switches off the burner and upon its cooling, automatically resets and the lighting sequence starts automatically. The second control (LC3) which operates at a higher temperature setting, will switch off the burner and itself set to a lockout condition which also requires manual intervention to reset to restore the heater to operational condition. A cooling time of ± 1 minute is necessary before re-setting.
- 7.5.10 When the set temperature or the heating time period has been reached, electrical power to the burner relay will be switched off and the

burner will extinguish. The air fan will continue to run until the heat exchanger has been cooled down to a safe level.

- 7.5.11 To turn off the air heater for a short period,
- turn room thermostat to lowest setting.
- To relight reset thermostat.
- For prolonged period;
- turn room thermostat to low setting,
 - turn gas supply to the appliance off.
 - switch off electricity supply to the air heater after air circulation fan has stopped.
- To relight follow lighting instructions.
- 7.5.13 The gas service tap must only be operated in emergencies, for servicing or prolonged periods of shutdown of the air heater.

SECTION 8. SERVICING & MAINTENANCE

Figure 8. FAN COMPARTMENT ACCESS

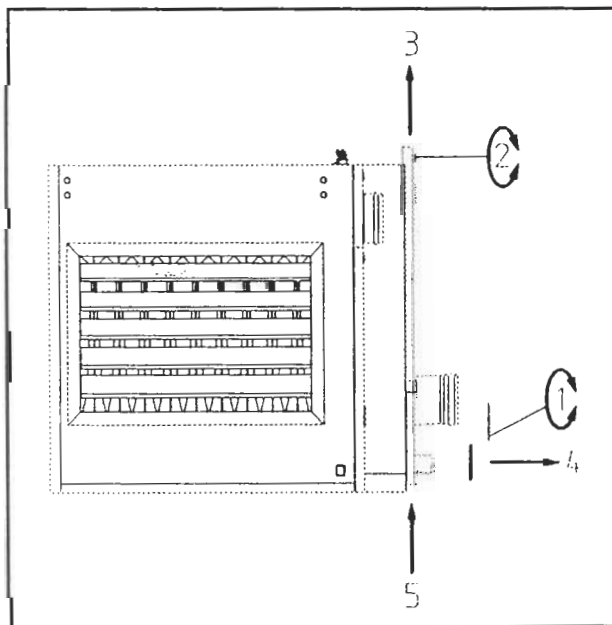

Legend figure 8:

- Remove trim plate
- Undo access panel securing catch
- Lift panel away
- Remove drain pipe panel seal
- Remove lower access panel

Figure 9. CONTROLS COMPARTMENT ACCESS

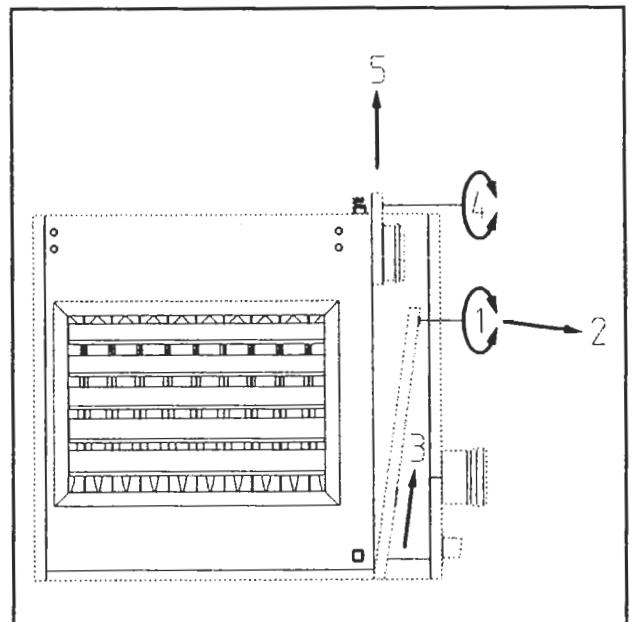

Legend figure 9

- Undo access panel catch
- Lift top of panel away
- Lift panel upwards to clear bottom retainer
- Undo upper panel catch
- Lift away upper panel

- 8.1 Before commencing servicing, turn off the main gas supply and switch off the main electricity supply **after the air circulation fan has stopped.**
- 8.2 It is recommended that maintenance is carried out at least once a year. More frequent servicing may be required dependent upon the environmental circumstances where the air heater is installed. Regular inspection is necessary, especially in dirty areas, to assess the servicing frequency.
- 8.3 Check condition and security of flue and combustion air system.
- 8.4 To gain access to the controls and flue gas fan assembly it is necessary to remove the casing panels after isolating the electrical and gas supplies to the appliance, see figures 8 & 9. All serviceable components are then accessible from the controls side of the appliance.

Figure 10. COMBUSTION AIR FAN & CONDENSATE DRAINAGE SYSTEM

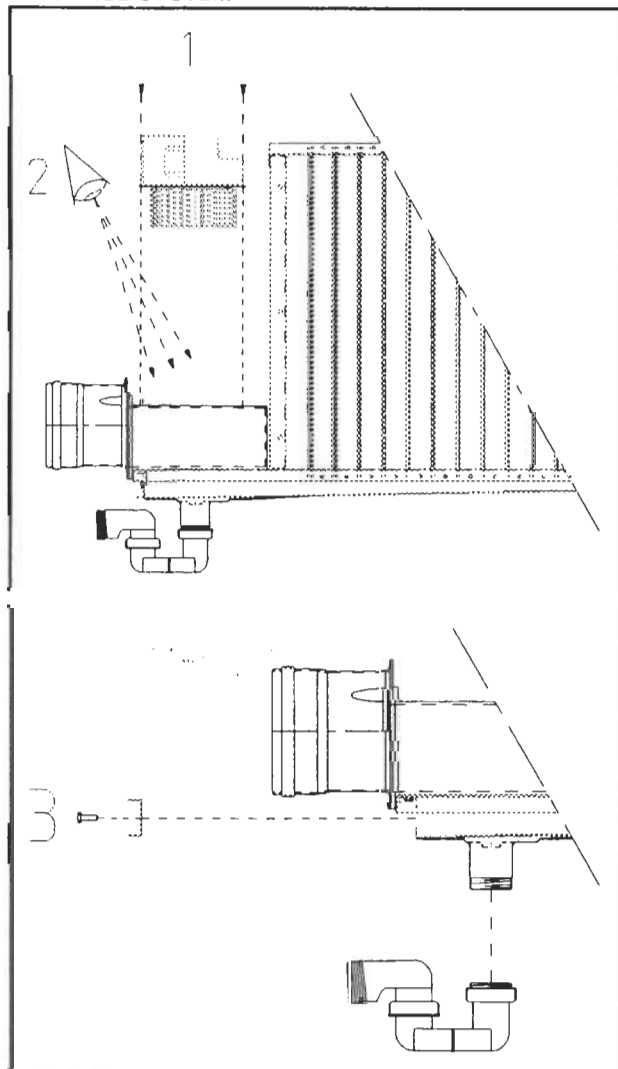

Legend figure 10.

1. Remove combustion air fan
2. Visually inspect condensate collector box

3. Removable access door if required for cleaning

NOTE: The secondary heat exchanger where condensation takes place has been designed to be sacrificial with regard to the normal corrosion that will take place therefore, it is anticipated that a small amount of oxide debris will be present. Excessive amounts will indicate possible contamination taking place due to the quality of the combustion air.

- 8.5 Check the condition of the condensate collector box and drainage system, see figure 10. Ensure that the "bubble-pot" trap is clean and free from oxide debris.
- 8.6 To gain access to the condensation collector box for inspection and cleaning remove the combustion air fan which is secured by 4 stainless steel screws into the fan housing, visual inspection is now possible. Additional access can be gained by removing the inspection cover plate fig.10 key 3 from the end of the box, 2 screws, taking care not to damage the sealing gasket unless a spare is available for replacement.

Remove any dirt accumulation from the combustion air fan taking care not to damage the fan impeller. Check that it rotates freely and is in balance after cleaning.

Flush the system with clean water after reconnecting the "bubble-pot" (trap) and cleaning access panel and check the entire drainage system for leaks and free flowing to outlet.

- 8.7 Check for security and worthiness of any suspension or mounting system.
- 8.8 Check that air circulating fan, guard, and motor are undamaged and secure.
- 8.9 Inspect hot surface igniter fig. 12 replace if in doubt about its condition.

Note: The Igniter device is fragile, therefore, handle carefully

- 8.10 Inspect and clean the burner assembly, refer to fig.11 for a guide to removal
- 8.11 Inspect heat exchanger and clean as necessary. This can only be done after removing the burner assembly. The use of an inspection lamp and mirror is necessary to carry out this operation.
- 8.12 After removal of burner assembly, each element of the heat exchanger can be cleaned by use of a soft brush and compressed air. Clean both inside and the outside surfaces.

- 8.13 Clean burners and gas jets with soft brush and compressed air. To prevent damage, do not use hard objects for cleaning the gas injectors. Any deposits can be easily remove by using acetone.
- 8.14 If anchor lines of service panels are removed for servicing, they must be replaced upon completion of the work.
- 8.15 Upon completion of any servicing re-commission the appliance in accordance with the step procedure described in section 7.2 of this document.

Fig. 11 REMOVAL OF BURNER ASSEMBLY

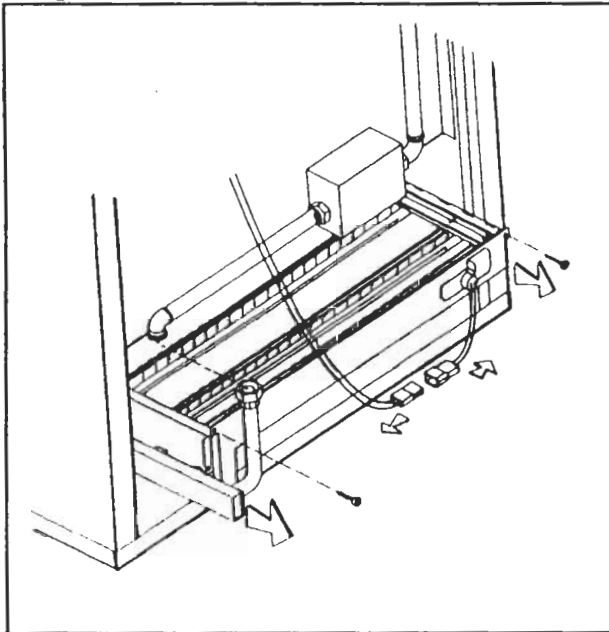

TO REMOVE BURNER ASSEMBLY:

1. Turn off the main gas supply.
2. Switch off the main electricity supply after air circulation fan has stopped.
3. Open service panel fig.9.
4. Disconnect wires of igniter.
5. Disconnect union fittings between gas valve(s) and burner.
6. Unscrew fixing screws of burner and pull forward burner assembly on it's slide rails.
7. Replace in reversed order

Figure 12. IGNITER ASSEMBLY

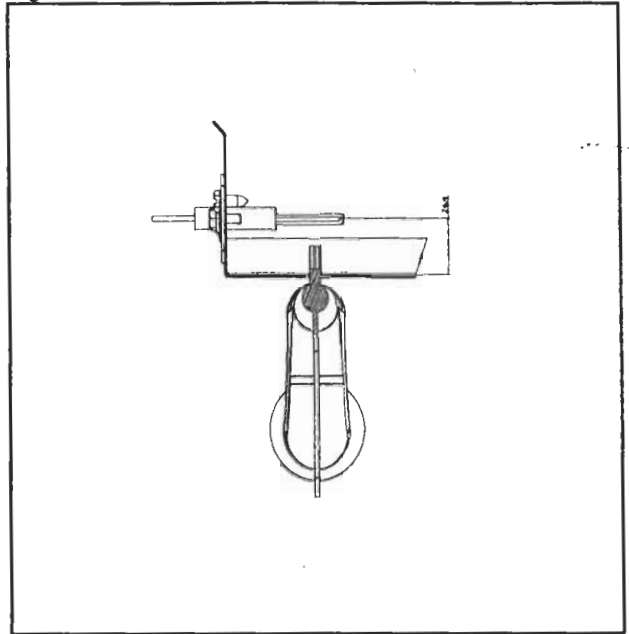
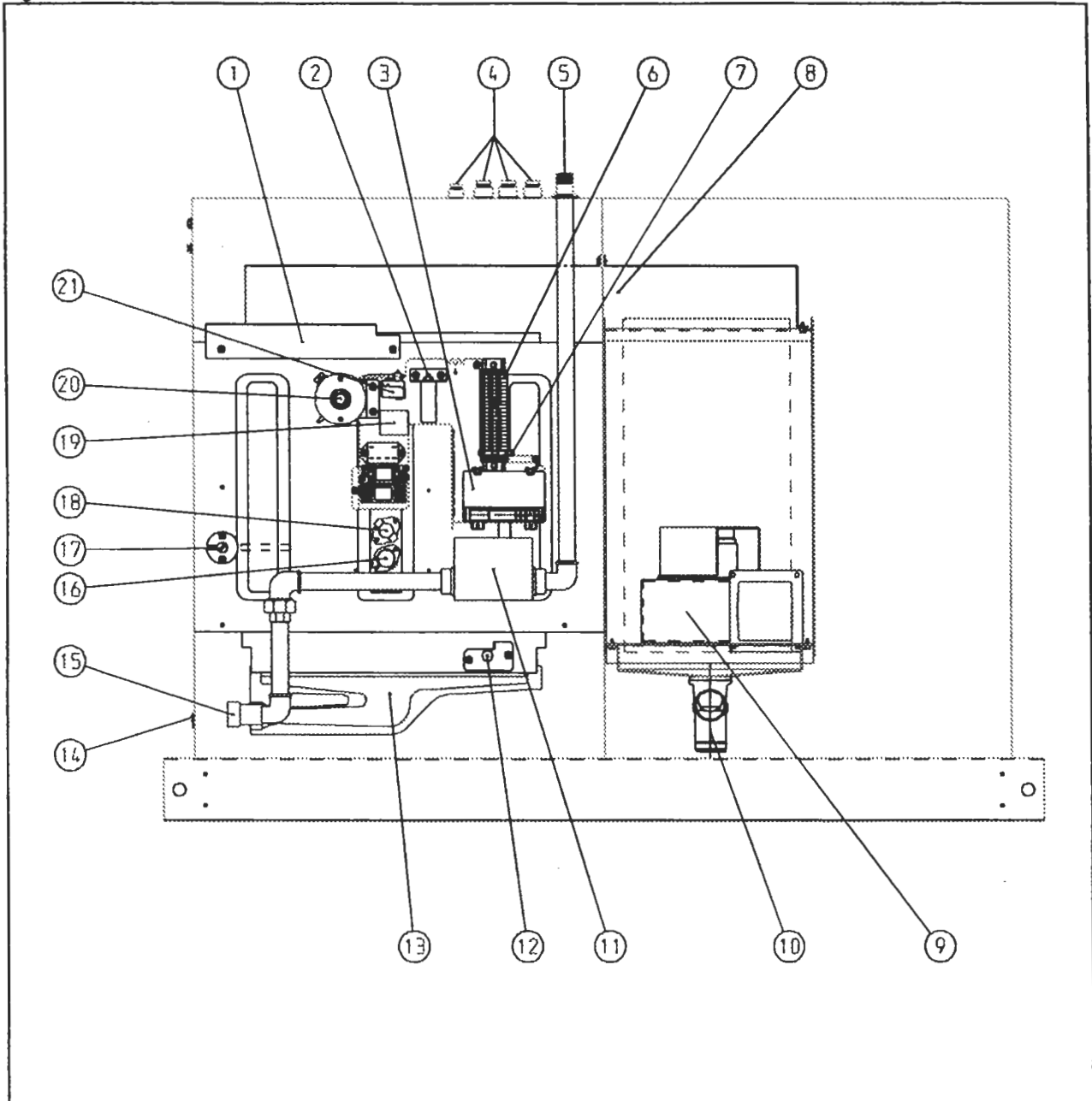

Figure. 12

COMPONENT PARTS LAY OUT



Legend:

- | | |
|---|--|
| 1. Heat shield | 11. Multi-functional gas valve |
| 2. Combustion air fan motor capacitor | 12. Hot surface igniter |
| 3. Electronic burner control | 13. Burner assembly |
| 4. Electrical & controls inlets | 14. Burner lockout indicator/reset |
| 5. Inlet gas connection | 15. Burner gas manifold, injectors & test point |
| 6. Electrical terminals | 16. Thermal fan control (FCR) |
| 7. Controls fuse | 17. Thermal over-heat control sensor (LC3) |
| 8. Flue gas pressure point | 18. Thermal over heat (limit) control (LC1) |
| 9. Direct drive combustion air fan | 19. Isolation transformer (NOT GB or IE) |
| 10. Condensation discharged trap (bubble-pot) | 20. Differential pressure control (flue gas fan) |
| | 21. Thermal overheat control (LC3) |

THE APPLIANCE WILL ONLY OPERATE CORRECTLY WITH ALL PANELS FITTED SECURELY!!.
GROSS OVER HEATING WILL OCCUR IF AIR CIRCULATING FAN ACCESS PANEL IS REMOVED
DUE TO SHORT CIRCUITING OF AIR STREAM

SECTION 9. FAULT FINDING

9.1 Burner does not ignite

- Thermostat set too low or time switch not correctly set; no power to terminals 2 and 5.
- Fuse F3 has blown; no power to terminal 2 and LC3.
- Reference tube to differential air pressure switch S3 is not airtight or blocked.
- Faulty differential air pressure switch S3; no power to terminals 2 and 13.
- Insufficient differential pressure in flue pipe system; Flue blocked or too long.
- Flue gas fan blocked; check
- Water level high in condensation collector box; check drain system.
- Burner relay in lockout (point 2 below) or faulty.
- Faulty combustion air fan M3 (venter).
- Faulty limit control LC1; no power to terminal 2 and LC1.
- Overheat control LC3 in lockout; no power to terminal 2 and LC3; Reset manually.

9.2 Flame relay in lockout

- Air in gas service; purge.
- Low gas pressure.
- Faulty hot surface igniter.
- Faulty differential air pressure switch.
- Gas valve does not open; no power to terminals 2 and 7.
- Insufficient ionisation flame current; ionisation current $\geq 2\mu A$.
- Incorrect wiring of mains input line, neutral, earth.

9.3. Combustion air fan (venter) does not start

- Faulty motor or capacitor.
- Faulty burner relay.
- Differential air pressure switch S3 still in normal run position no change-over.
- Faulty fuse F3.

9.4 Differential air pressure switch switches burner off

- Switch-point should be;
30067 - ON = 1,37 mbar, OFF = 1,30 mbar
30087 - ON = 0,92 mbar, OFF = 0,85 mbar
30107 - ON = 0,45 mbar, OFF = 0,38 mbar
- No differential pressure in flue gas system; check flue and air inlet.
- Faulty combustion air fan or capacitor.

9.5 Appliance does not provide sufficient warm air

- Check gas inlet pressure.
- Check burner pressure.
- Gas filter (if fitted) dirty or blocked.
- Limit control LC1 switches burner off (see 9.6).
- Differential pressure switches relay off (see 9.4).

9.6 Limit control LC1 switches burner off

- Switch temperature 51,5°C,
- Insufficient air flow.
- Vertical and horizontal louvres set in closed position.
- Burner overload, check burner and inlet gas pressure.
- Fan control switch faulty
- Check fan rotational direction.
- Air temperature at fan inlet too high; T max. 30°C (see 9.6).
- Thermal contact in fan motor switches off intermittently.

9.7 Limit control LC3 switches

- Switch temperature 96°C (+0/-5).
- Check location and security of capillary and probe.
- Air discharge temperature too high (see 9.6).
- Faulty limit control LC1.
- Air fan stops immediately after burner is switched off; incorrect control/s wiring.
- Faulty fan control (FC).

9.8 Air fan does not start

- No power to terminals 2 and 11.
- Faulty fan control (FC).
- Faulty motor or capacitor.
- Thermal over-load in motor switching.

9.9 Fan starts and stops intermittently while burner is on.

- Faulty heat anticipator (FCR) in fan switch.
- Thermal over-load in motor switching.
- Inlet ambient air temperature too low; T min. <5°C.; will correct as space temperature rises.
- Faulty wiring connection; loose terminals!

SECTION 10. SPARE PARTS LIST

10.1 GAS SECTION

DESCRIPTION	PART NUMBER	MFGS. REF.	APPLICATION
Gas valve single stage burners	03 25136	H'well VR4601AB	All
Gas valve two stage burners	03 35136	H'well VR4601BP	Two stage options

10.2 ELECTRICAL SECTION

DESCRIPTION	PART NUMBER	MFGS. REF.	APPLICATION
Thermal fan control	03 25166	TOD29T12 (250V)	All
Thermal over-heat control (limit) LC1	03 24970	TOD60T11	All
Thermal over-heat control LC3	03 24959	limit 96° C	All
Combustion fan assembly	80 25867 01	EBM	All
Combustion circuit pressure switch	30 60615 067	Huba 604. 9...	30067 S
Combustion circuit pressure switch	30 60615 087	Huba 604. 9...	30087 S
Combustion circuit pressure switch	30 60615 107	Huba 604. 9...	30107 S
Automatic burner control	03 25317	Honeywell S4570LS	All
Hot surface ignition device (assy)	36 25217	Norton 240V	All
Two pole relay K1.2	30 61738 240V	Omron G7L2A	All two stage burners
Capacitor combustion fan motor	01 25600 2.5 mf	2.5 mfd 400V	All
Wiring harness for burner control	06 41631 HGC	---	All
Wiring connector for igniter device	06 41531 HGC	---	All
Wiring harness for two stage burners	06 41621	---	All
Wiring terminals	06 41635	Entrelec	All

10.3 AIR HANDLING SECTION

DESCRIPTION	PART NUMBER	MFGS. REF.	APPLICATION
Fan motor	01 26006 09	MXC70P6	30067 S
Fan motor	01 26006 12	MXC50L6	30087 S
Fan motor	01 26006 16	MXC65L6	30107 S
Axial fan	02 26008 09	S60/3PR25	30067 S
Axial fan	02 26008 12	S70/3PR17	30087 S
Axial fan	02 26008 16	S70/4PR20	30107 S

ALWAYS SPECIFY APPLIANCE SERIAL NUMBER WHEN ORDERING SPARE PARTS

10.4 MISCELLANEOUS

DESCRIPTION	PART NUMBER	MFGS. REF.	APPLICATION
Sampling pressure test point	07 25811 02	M8	All
Silicon tubing	06 20224 cm	φ 5-8 mm x 1.0 m	All
Combustion fan assembly gasket	11 44696	---	All
Capillary seal gasket	06 07726	---	All
Capillary seal plate	08 07727	---	All
Gasket condensate collector box cover	06 71590	---	All
Condensation drain trap (bubble pot)	70 61765	---	All

ALWAYS SPECIFY APPLIANCE SERIAL NUMBER WHEN ORDERING SPARE PARTS

SECTION 11. GAS CONVERSION

- 11.1 This air heater is designed to operate on natural, propane or butane gas and will be supplied as ordered for the gas type specified. In the event it is required to convert to a different gas type to that which has been supplied, conversion of the gas burner must be carried out.
- 11.2 A Reznor approved conversion kit to suit the appropriate gas type must be used.
- 11.3 In addition to changing the burner injectors, and adjusting the gas pressure sealing a governor or fitting a blanking plate it is necessary to fix over stickers as supplied with the conversion kit of parts.
- 11.4 After conversion re-commission appliance according to section 7 of this document.

Figure. 13 BURNER AIR SHUTTER AND SETTING DIMENSION for all GASES GB & IE

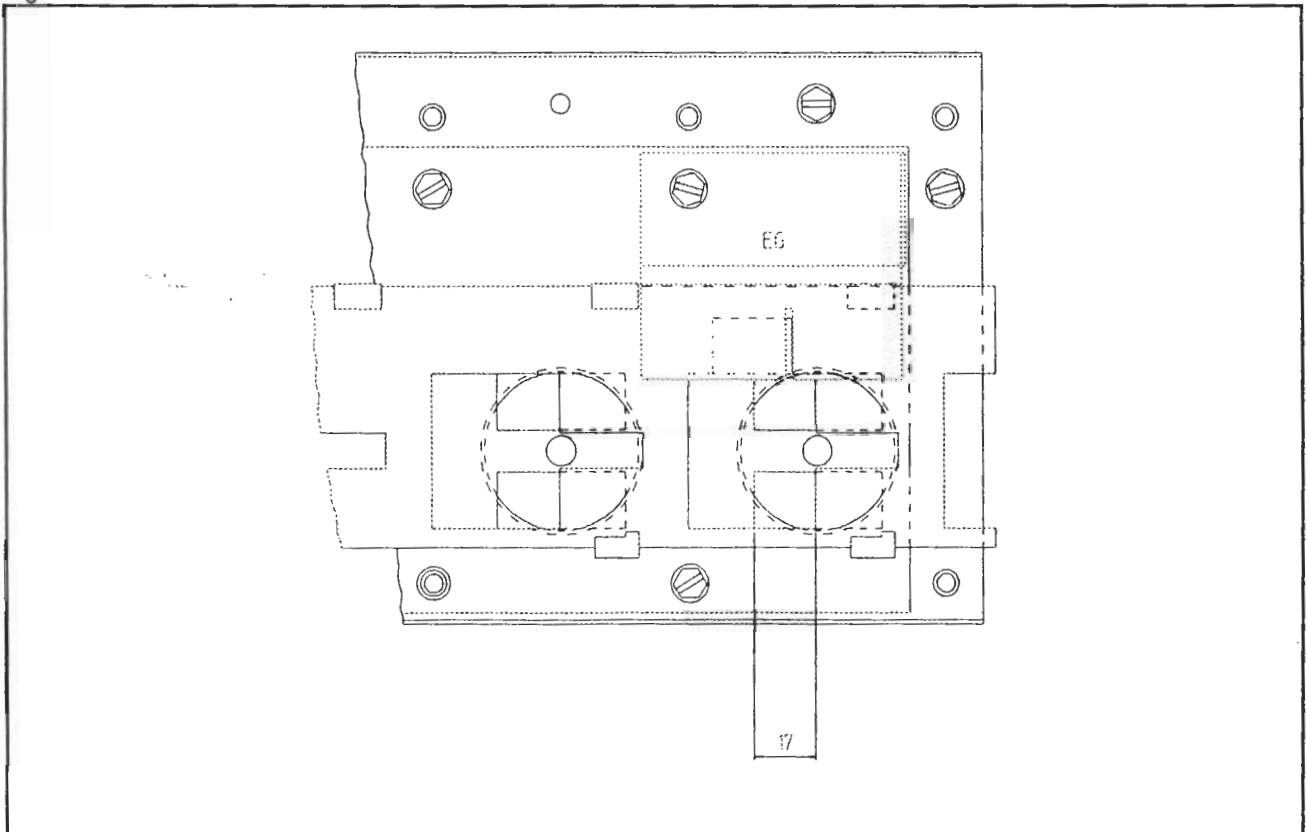

SECTION 12. HEALTH & SAFETY STATEMENT

Health and Safety Information for the Installer and Commissioning-Service Engineer

Under the Consumer Protection Act 1987 and Section 6 of the Health and Safety at Work Act 1974 we hereby provide the following information on substances hazardous to health.

Product range reference EURO-H 30000 Series air heaters.

12.1 Cautionary note

During first firing some smoking may occur, this is due to the burning off of protective/lubricating oils used during appliance production. Most of this will have been removed during the production testing process. It is a wise precaution to ensure that adequate ventilation is provided during the initial firing and throughout the commissioning period, this is particularly important if the discharge air is to blow into a confined space. This smoking does not constitute a poison hazard.

12.2 Declaration

Reznor products contain no asbestos; copper is not employed in gas carrying components; solder which has a melting point below 450°C is not used; paints for corrosion protection and decoration are heat cured and contain no lead.

The above appliances meet the Electrical Safety requirements of EN60 335 Pt 1 1988.

12.3 Miscellaneous

Small quantities of adhesives and sealants used in the product are dried and cured and present no known hazard.

12.4 Insulation and Seals.

Material: Synthetic Ceramic Fibre with Organic binder.

Description: Tapes and Papers

Known hazards: Some people can suffer reddening and itching of the skin. Fibre entry into the eyes will cause foreign body irritation. Inhalation will cause irritation to the respiratory tract. As with any dust pre-existing respiratory condition and lung diseases may be aggravated.

Prolonged exposure for the purposes envisaged pertaining to this Reznor product is not anticipated.

Precautions: Wear protective gloves when handling. If abrading and dust is generated suitable protective respirators must be used.

People with a history of skin complaints may be susceptible to irritation.

Dust levels are only likely when the material is abraded.

In general normal handling and use for this purpose will not present discomfort. Follow good hygiene practices, wash hands before

consuming food or using the toilet.

First Aid: Medical attention must be sought following eye contact or prolonged reddening of the skin.

12.6 Thermostat.(Thermal overheat (limit) control LC3)

Material: Illuminating Kerosene.

Description: Sealed phial contains a small quantity in liquid form.

Recognition: Colourless liquid, paraffin oil/petroleum hydrocarbon odour.

Characteristics: Non-corrosive, flammable with no poisonous reference-CH poison Class 3

Precautions: Avoid handling. This product can irritate and de-fat the skin. Prolonged contact may cause dermatitis. Avoid breathing vapour. Avoid eye contact. Do not ingest.

First Aid: Skin. Wash thoroughly with soap and water.

Eyes. Rinse immediately with copious amounts of clean water.

Ingestion: Seek medical advice.

NOTE: If skin irritation persists seek medical advice.

12.7 Electrolytic Capacitor

Two types are used by random selection:

Recognition: 1. Plastic enclosure 2. Aluminium enclosure

Material: Contained liquid electrolyte

Known hazards: Electric shock possible if charged.

Precautions: Discharge to ground/earth. Do not incinerate.

First Aid: Treat for electric shock if affected.

12.8 CAUTION: Condensate water may be acidic (hydrochloric) to PH 3.0 This equates to vinegar exercise caution when in contact with the skin.

H & S ENDS

Reznor 08/01

SECTION 13. USER INSTRUCTIONS

OPERATING

How the air heater works:

Gas is burned by an atmospheric burner which fires into a heat exchanger. The gas burner is controlled by a double gas valve via an electronic burner control, which is actuated automatically via external controls i.e. a room thermostat and/or a time switch. The burner is ignited by a hot surface igniter. When the burner fires and warms the heat exchanger, the heat is sensed by a thermally actuated fan control which switches on the fan when the air temperature has reached its preset operating level.

At the end of a heating cycle the burner is switched off, the air circulation fan will continue to run until the air heater has cooled to a safe condition. Thereafter the fan will remain off until the next cycle is initiated.

Safety:

1. Flame failure is detected by the hot surface igniter which is also the sensor and will immediately result in gas valve shut down.
2. Safety against overheating is assured by two overheat controls. The first is an automatic recycle control which protects against low air flow i.e. clogged air ways, fan failure etc. The second, which is set to a higher level than the first one, is a control which locks out and switches off the burner in the event of gross overheating for any reason. Manual intervention is necessary to reset this control device. Resetting of the automatic burner control may also be required.
3. The location of the air heater should be maintained at normal atmospheric pressure. Changes to the building after air heater installation, should have regard to the heating installation, i.e. structural changes causing excessive draughts from doors, windows etc. Other air handlers and installation of air extraction equipment which may cause a negative pressure environment, can seriously affect the operation of this type of air heater, especially if combustion air supply is not ducted.

To light the heater:

1. Turn on the gas supply to the air heater.
2. Switch on the electricity supply to the air heater.
3. Ensure time switch (if fitted) is set to a 'ON' cycle.
4. Adjust control/room thermostat to desired temperature.
5. Air heater will light automatically when the room thermostat calls for heat.

6. If the appliance does not light:
 - a) check that the burner control does not require resetting. An indicator light glows at the front panel of the appliance and on a remote control (if fitted). Reset by pushing light/button on appliance or the remote control.
 - b) check if thermal overheat control requires resetting (see fig. 12 key 14).
7. If the thermal overheat control requires resetting and doing so restarts the air heater, wait until the appliance warms to thermal equilibrium, to ensure the overheat control does not lock out again. **If it does and the temperature near the heater is less than 30°C, then switch off the appliance and call for service.** If the temperature is over 30°C, take appropriate action to reduce the ambient temperature near the air heater.

Air circulation:

1. The space heating process is for air to be circulated through the appliance whereby it gains heat from a heat exchanger. The air is directly discharged into the space to be heated. The air is eventually re-circulated. Therefore it is very important that an unobstructed path for the circulation of the air will be maintained. This is particularly important if the air heater has been installed to blow through the wall between two rooms.
2. Sometimes the air circulation fan of the appliance is connected to a remote over-ride switch. This enables cool air to be used for circulation purposes when the air heater is not used for heating purposes e.g. in summer.
To use this feature:
 - a) switch ON electricity
 - b) switch ON manual override switch, this may be fitted as a feature on a remote composite control.

Maintenance:

1. Maintenance and service must only be carried out by appropriately qualified persons e.g. "Corgi" registered undertakings.
2. It is in your interest to ensure proper service and maintenance is carried out at a regular basis. Periods between service are dependent upon the local environment where the heater is installed. All gas appliances should be serviced at least once a year.
3. In case of any damage to the appliance, it must be shut down completely and checked by an appropriately qualified person. 4. In the event of difficulties in resolving any of these matters, please do not hesitate to contact Reznor or their official distributor.

NEVER SWITCH OFF ELECTRICITY SUPPLY TO THE AIR HEATER WITHOUT FIRST CLOSING THE INLET GAS TAP. DO NOT USE THE AIR HEATER WITH THE ACCESS PANELS OPEN. DOING SO WILL CAUSE OVERHEATING RESULTING IN DAMAGE TO THE APPLIANCE.

Reznor® EURO-H 30000 S

ONE OF THE Reznor GENERATION OF CE MARKED GAS FIRED
HIGHLY ENERGY EFFICIENT AIR HEATERS

BEST USED WITH Reznor OPTIONAL ELECTRONIC CONTROL PANELS
SAVE ENERGY AND OPTIMISE THERMAL COMFORT

Reznor® Europe N.V.
J&M Sabbestraat 130
B8930 Meneen
Belgium
Tel: +32(0)56 52 95 11
Fax: +32(0)56 52 95 33
e-mail: reznor_europe@tnb.com

Reznor UK Limited
Park Farm road
Folkestone
Kent
CT19 5DR
Tel: + 44 (0)303 259141
Fax: + 44 (0)303 850002
e-mail: sales@reznor.co.uk

Thomas & Betts