

GAS FIRED AIR HEATERS TYPE EURO-T 2000 B

Centrifugal Blown, Forced Convection Appliances with
Automatic Ignition and Fanned Flues for use as:
Type B22 - C12 - C32

INSTALLATION COMMISSIONING SERVICING & USER INSTRUCTIONS

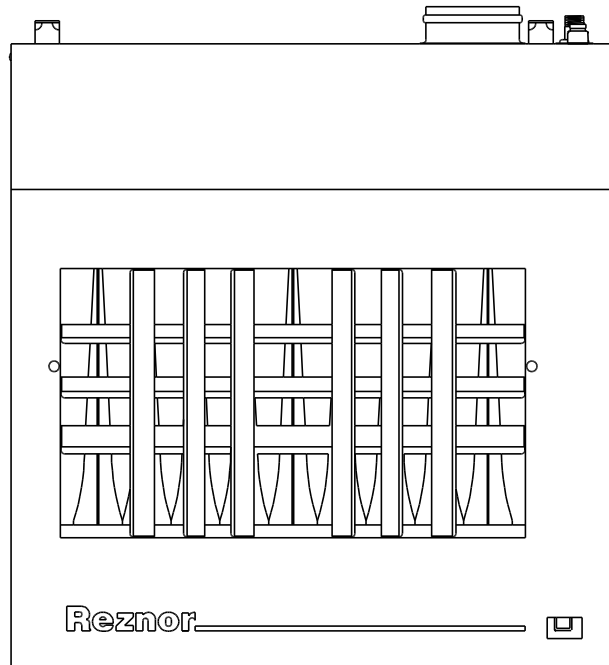

These appliances meet the following EC Directives:

Dir. CE 90/396/EEC:GAD

Dir. CE 89/336/EEC:EMC

Dir. CE 89/392/EEC: MD

Dir. CE 73/23/EEC: LVD

PLEASE READ THIS DOCUMENT CAREFULLY BEFORE COMMENCING INSTALLATION AND LEAVE IT WITH THE USER OR ATTACHED TO THE APPLIANCE OR GAS SERVICE AFTER INSTALLATION.

INDEX

	<u>Page</u>
1. General	2
2. Technical data	3
3. Installing.....	5
4. Combustion, Air supply and flue system.....	7
5. Gas connection.....	9
6. Electrical connection.....	9
7. Commissioning, lighting and operation.....	10
8. Maintenance	12
9. Fault finding	15
10. Spare parts list.....	16
11. Gas conversion.....	17
12. Health and Safety Statement.....	18
13. User instructions	19

If optional equipment was ordered and supplied with this air heater, please refer to additional instructions for option(s).

SECTION 1. GENERAL

- | | |
|--|---|
| 1.1 Before installation, check that the appliance as described on the packaging label is in accordance with the correct type and model as specified on the data plate and complies with your customer order. | recommendations of British Standard BS 6230 1991. "Installation of Gas Fired Forced Convection Air Heaters for Commercial and Industrial Space Heating".
The Installation must also be in accordance with the relevant requirements of "The Gas Safety (Installation and Use regulations) and (Amendment Regulations 1990)" and The "Building" and "Electrical Regulations" (in GB the IEE Regulations).
The requirements of the "Local Building Standards Office", the premises "Insurance" undertaking and the "Fire Office" must also be observed. |
| 1.2 After unpacking the appliance, leave it fastened to the wooden pallet until it has been suspended or until just before base mounting. This affords protection to the painted underside which is normally exposed to view after installation. | |
| 1.3 Please read this document before commencing installation. | |
| 1.4 These instructions are only valid for the country of use indicated on the appliance i.e.: GB - IE. If these symbols are not shown, it is necessary to obtain appropriate technical instructions which will provide information concerning the necessary modification of the appliance for the conditions of use in the country concerned. Such instructions may be obtained upon request from your supplier. | 1.7 Unauthorized modification of this appliance or departure from use in the manner for which it was intended by the manufacturer or installation in a manner contrary to these instructions, may constitute a hazard and jeopardize all warranties. Deviations should only be carried out after formal consent has been obtained from the manufacturer. |
| 1.5 Check that the local distribution conditions of electricity supply, type of gas and pressure, and adjustment of the appliance are compatible. | 1.8 Ensure the environment in which the air heater will be installed will not create a hazard i.e. where excessive (volatile) dust, flammable or corrosive substances and/or vapours and combustible materials may be present. |
| 1.6 When installed in Great Britain the total installation must comply with the requirements and | 1.9 This appliance has been tested, and set according to the data plate before leaving the factory. |

SECTION 2. TECHNICAL DATA

Table 1. Appliance Data Standard Efficiency Models

EURO-T	Standard Model #	2025B	2030B	2035B	2045B	2055B	2075B	2095B	
EURO-T	Low NO _x #	2525B	2530B	2535B	2545B	2555B	2575B	2595B	
Gas category 'Cat.'		II _{2H3+}							
Air supply and flue type		B22 - C12 - C32							
Heat input (Hs) 'Qn'	kW	28,8	35,2	42,7	49,9	63,2	86,5	115,4	
Heat input (Hi) 'Qn'	kW	26,0	31,7	38,5	45,0	57,0	78,0	104,0	
High heat output	kW	22,8	27,8	33,7	39,4	49,9	68,3	91,0	
Number of jets		4	5	7		9	12	16	
Jet size	natural gas	Ø mm	2.4		2.2	2.4			
	propane/butane	Ø mm	1.35		1.25	1.35			
Gas supply pressure 'P' ¹	natural gas	mbar	17.5						
	propane	mbar	37.0						
	butane	mbar	30.0						
Burner pressure ²	natural gas	mbar	8.50						
Gas consumption	natural gas ³	m ³ /h	2.74	3.36	4.04	4.76	6.02	8.30	11.00
	propane	kg/h	2.06	2.52	3.05	3.56	4.51	6.18	8.25
	butane	kg/h	2.10	2.60	3.12	3.64	4.61	6.31	8.42
Gas service connection (not supply line size)		Rc ¾							
Temperature rise ΔT (± 1)	K	32	31	31		26	32		
Air volume ⁴	m ³ /h	2100	2600	3700		4700	6300	8400	
Mounting height	m								
Throw (terminal V _O = 0,5 m/s)	≤ m	24	25	31		32	34	47	
Nominal fan speed	rpm	800	525	750		550	650	500	
Sound power level L _w	dB(A)	70	67	70		74			
Sound pressure level L _p ⁵	dB(A)	55	52	55		59			
Electrical supply		230/240V 1 N ~ 50Hz					400V 3N ~ 50Hz		
Protection grade		IP20							
Fan motor rating	W	0,18		0,25		0,37	0,55	0,75	
Total electric rating ⁶	W	0,50		0,55		0,68	0,93	1,15	
Appliance weight net	kg	108	135	155		168	193	248	
Appliance weight gross (shipping)	± kg	130	158	173		194	242	281	

- 1 Maximum gas pressure at inlet to appliance = 50,0 mbar
- 2 All casing panels fitted, service door open
- 3 Natural gas G20, calorific heating value 10,48 kWh/m³ on Hs @ 15°C & 1013 mbar
Propane G31, calorific heating value 14,0kWh/kg
Butane G30, calorific heating value 13,7 kWh/kg
- 4 Isothermic condition (20°C)
- 5 Q=2, A=160 2m², louveres no deflection, isothermic condition,
- 6 Total electrical rating during the start-up period ± 30 seconds is increased by 130 W and is not included on the appliance data plate or in the above table

Table 2 Appliance Data Higher Efficiency Models

EURO-T	Standard Model #	2026B	2031B	2036B	2046B	2056B	2076B	2096B
EURO-T	Low NO _x Model #	2526B	2531B	2536B	2546B	2556B	2576B	2596B
High fire heat output	kW	23.7	28.8	35.0	41.0	51.9	71.0	94.6
Temperature rise ΔT (± 1)	K	33	32	28	32		23 32	

Note: All other data as standard model

Figure 1. DIMENSIONS

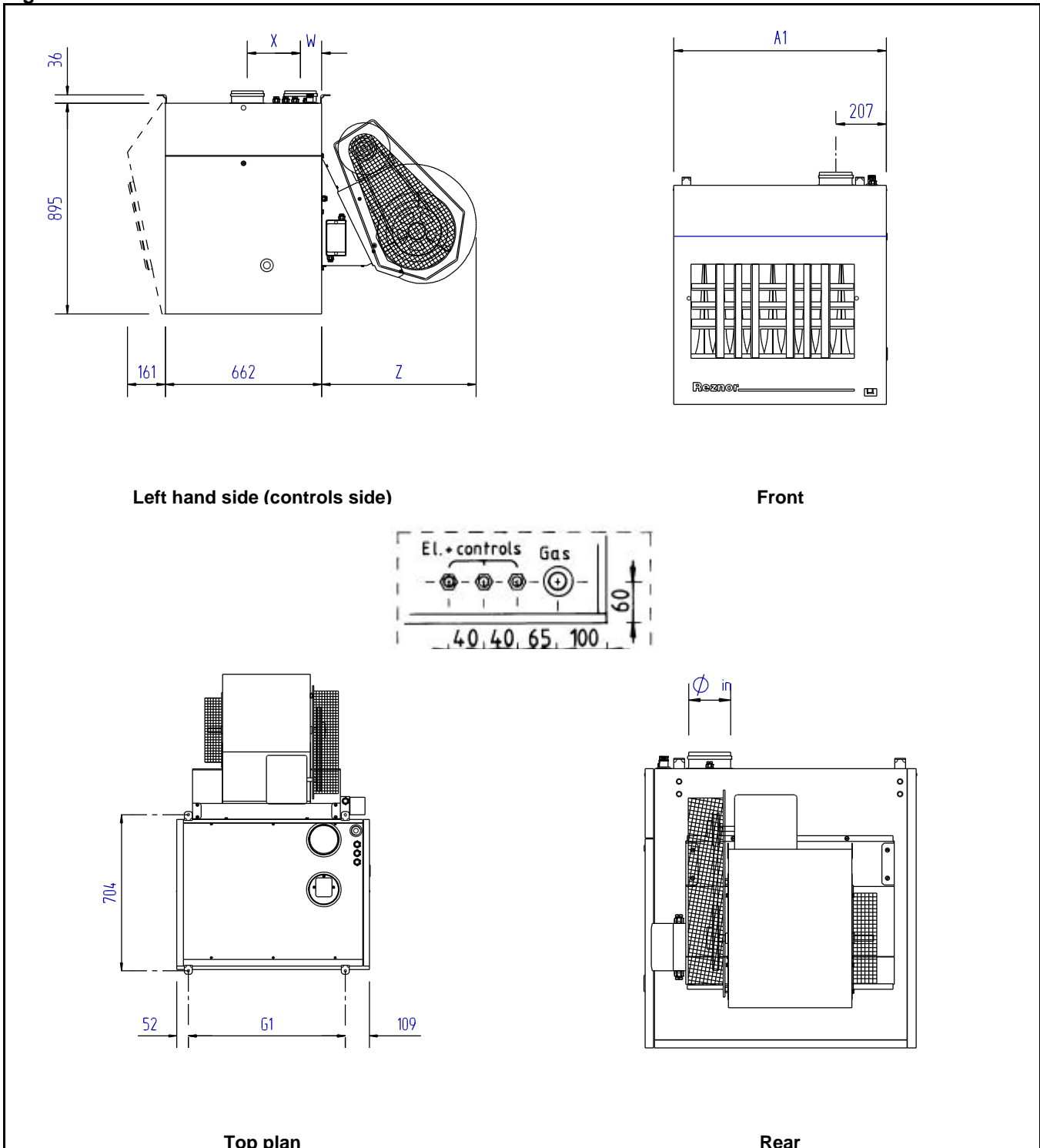

Table 3 Dimensions reference figure 1

Model	2025 2026	2030 2031	2035 2036	2045 2046	2055 2056	2075 2076	2095 2096
Dimensions							
A1 Width overall	520	590	730		870	1080	1360
Ø Flue & combustion air intake socket internal Ø	102			132			
X Flue & combustion air intake socket centres	140			225			
G1 Width of suspension points	359	429	569		709	919	1199
Z Fan assembly overall depth	518	575	668			575	668

SECTION 3 INSTALLING

Figure 2 Suspension & Base Mounting

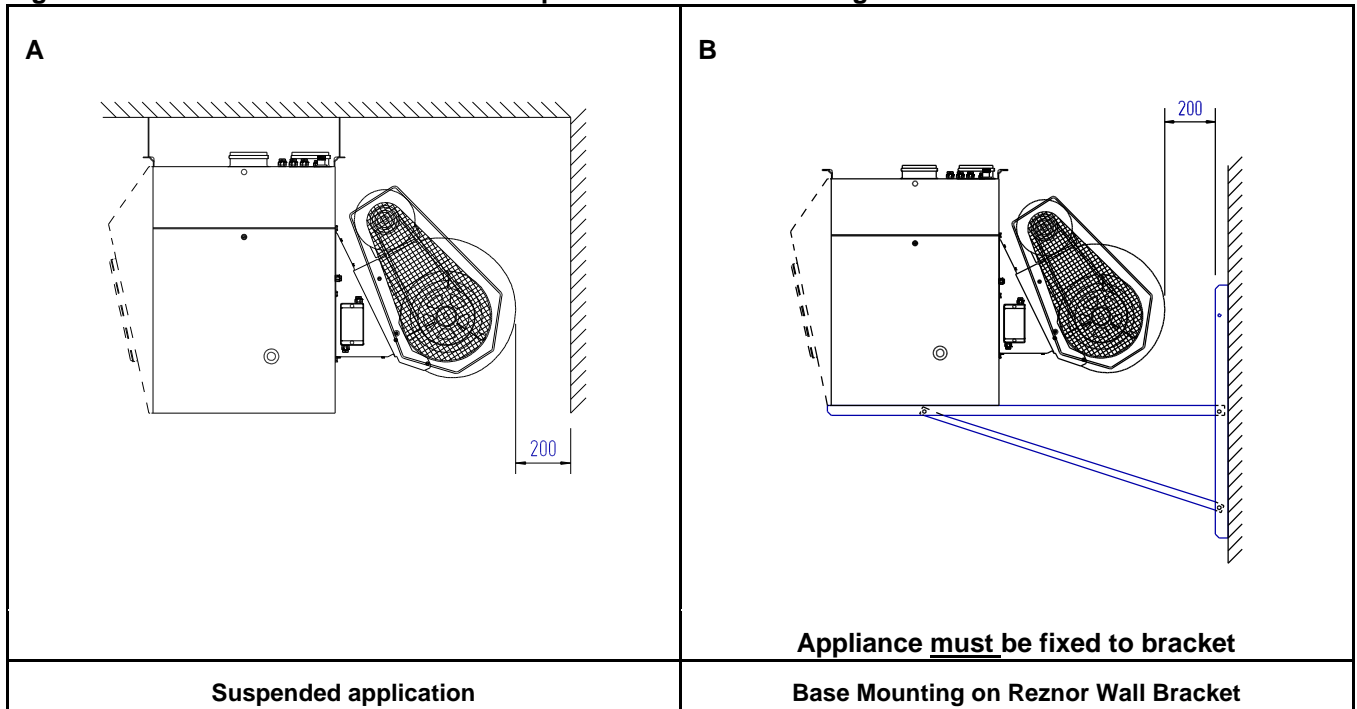

Figure 3 Combustion Clearances & Service Access

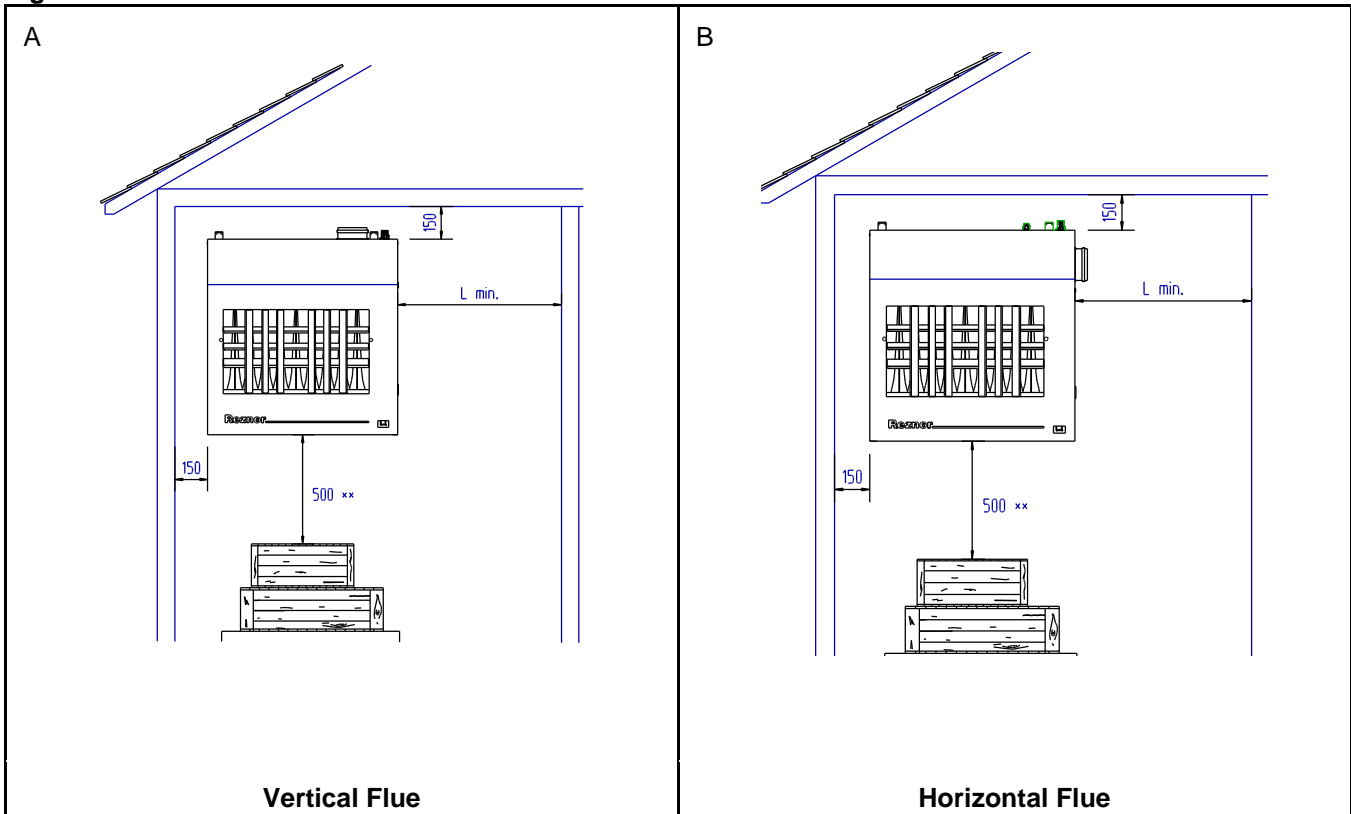

Table 4 DIMENSIONS Re: FIGURE 3

Model	2025	2030	2035	2045	2055	2075	2095
Dims.	2026	2031	2036	2046	2056	2076	2096
L min.	550	620	750	750	900	1100	1400
L Min.*	-	-	-	-	-	150 + 300	150 + 300

Note: * Models 2075/76 & 2095/96 require extra side clearance for access to LC 2 thermal overheat control when air heater is equipped with 2 separate blowers.

- 3.1 Figure 3 shows the clearances necessary to ensure safety for combustibles and service access.
- 3.2 Ensure that the structural elements which will be used to suspend or support the appliance, are adequate to carry the weight of the appliance and its ancillary components i.e. flue system.
- 3.3 The location where the air heater is to be installed, must provide sufficient space around the heater for servicing and clearances for safety.
- 3.4 Ensure that the air heater is installed in a level plain.
- 3.5 Base mounting is optional; see fig. 2-B. The air heater must be fastened securely to any base mounting arrangement.
- 3.6 4 suspension brackets with holes \varnothing 10.5 mm are provided on top of the appliance. Use \varnothing 10 mm rods for suspending the heater.
- 3.7 If the appliance is to be suspended from cantilever brackets specially designed wall brackets should be manufactured to suit the application respecting the clearances indicated in figure 2 and the live load factors the appliance will impose.
- 3.8 After suspension, the air heater should be rigid so as to avoid placing a strain on the flue system, gas services and electrical wiring. Optional 1" BSP threaded sockets are available for alternative suspension arrangements.

SECTION 4. COMBUSTION AIR SUPPLY AND FLUE SYSTEM

- 4.1 Flue systems must comply with national and local regulations.
- 4.2 The products of combustion must be flued to outdoor atmosphere. Common flues for more than one appliance must **NOT** be used.
- 4.3 Combustion air should be taken from out-door atmosphere, this improves the operational efficiency of the heating system.
- 4.4 Flues and combustion air ducts where connected to the air heater must incorporate a disconnect section adjacent to the appliance to facilitate removal of the venter assembly for service and replacement purposes. The flue system must therefore, be supported independently.
- 4.5 Dimensions and allowances in suggested flueing and combustion air intake arrangements are based upon the use of smooth wall aluminium flue and combustion air ducts and fittings equipped with positive sealing gaskets.
- 4.6 **Type C Appliances**
- 4.6.1 When using the concentric termination as fig. 4 arrangement, then only an approved system using Reznor specified components may be used. These items are manufactured from seamless aluminium with connection sockets fitted with silicone double edged seals, thus assuring, if the components are undamaged, leak free flue systems.
Important: This type of flue/Combustion air intake system is regarded as an integral part of the air heater therefore, departure from these methods of flueing as published in this document is in breach of the EC Gas Appliance Directive.
- 4.6.2 Distances between the appliance and the concentric flue termination must not be greater than 9.0 m. When calculating the total length the following data must be taken into account:
- 1 elbow @ 45° = 1 m
1 elbow @ 90° = 1,5 m.
- 4.7 **Type B Appliances**
- 4.7.1 If the air heater is to be installed as a B type appliance as fig.5 i.e. air for combustion to be taken from within the space to be heated, then it must be ensured that an adequate air supply for combustion and ventilation is provided, in accordance with the regulations and rules in force.
- 4.7.2 A horizontal distance between air heater and flue terminal and any combustion air intake duct, must not be in excess of 16 m.
Note: 2 Meters of vertical rise negates the resistance imposed by 1 meter of horizontal run.
Runs exceeding 16 m may be subject to condensation forming within the flue.
- Equivalent lengths of flue fittings:
- Elbow @ 45E = 1 m
Elbow @ 90E = 1,5 m.
Flue terminal ≤ 3.0 m
- 4.7.3 To ensure that the allowable resistance is not exceeded in the case of horizontal runs of flues, a positive rise from the air heater of 1° i.e. 17 mm per metre is recommended.
- 4.7.4 If condensation is to be avoided, flues should not pass through cold areas or not be installed externally.
- 4.7.5 When mechanical ventilation is used, it shall be by mechanical inlet with either mechanical or natural extraction. Automatic means of control such as interlocks must be provided. The function of other ventilation systems in the zone where the air heater is installed must be taken into account. At no time should it be possible to create a negative pressure environment in the zone, this can lead to a hazardous situation, whereby the air heater flue may act as a pressure relief.
- 4.7.6 The terminal of a vertical flue must extend at least 1 m above a roof surface; flues must not be located where products of combustion might enter the building. Terminals must be fitted to all flues and combustion air inlets. **The combustion air inlet if not used must be protected with an access guard.**

WHEN INSTALLED AS A TYPE C APPLIANCE

Figure 4. FLUE AND COMBUSTION AIR INTAKE ARRANGEMENTS

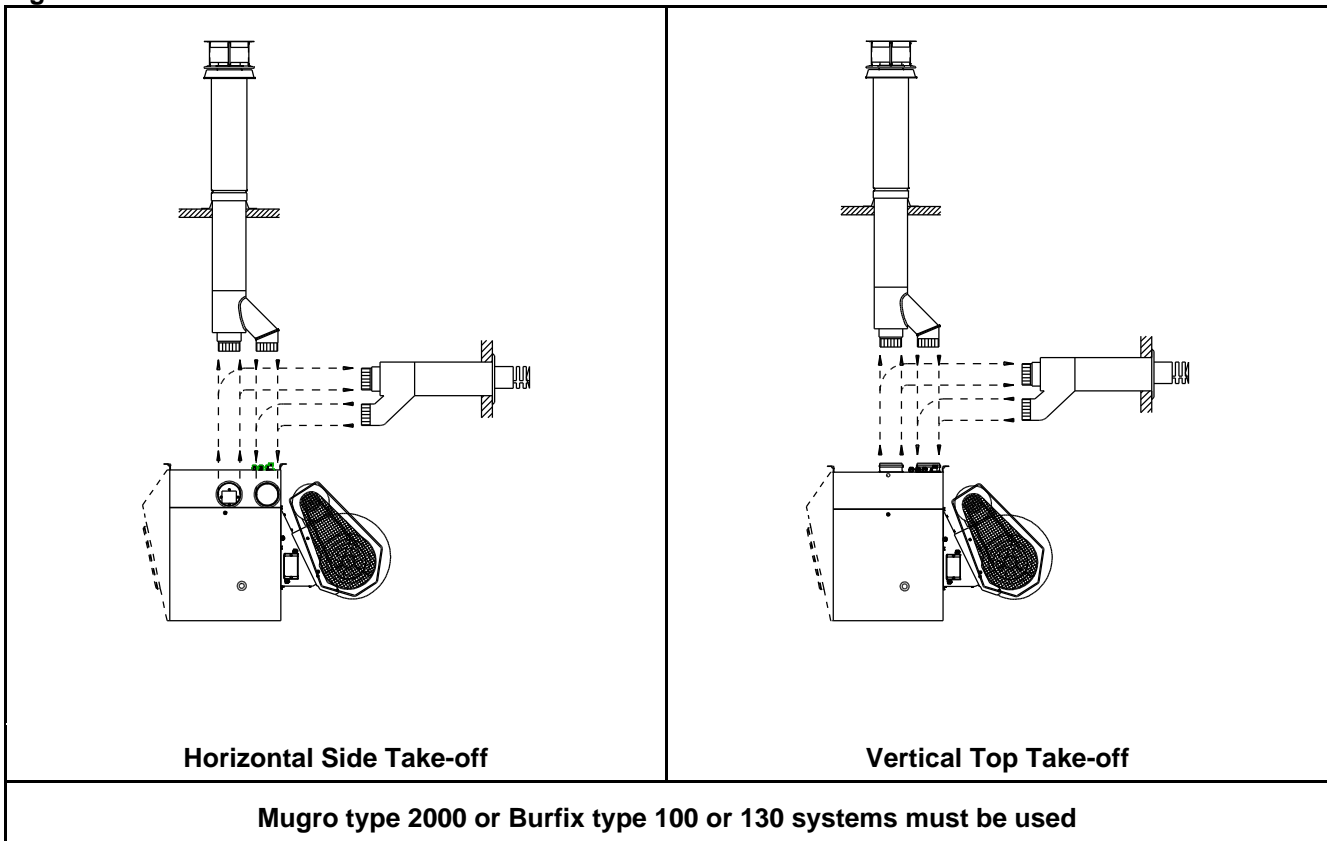

WHEN INSTALLED AS A TYPE B APPLIANCE

Figure 5. FLUE AND COMBUSTION AIR INTAKE ARRANGEMENTS

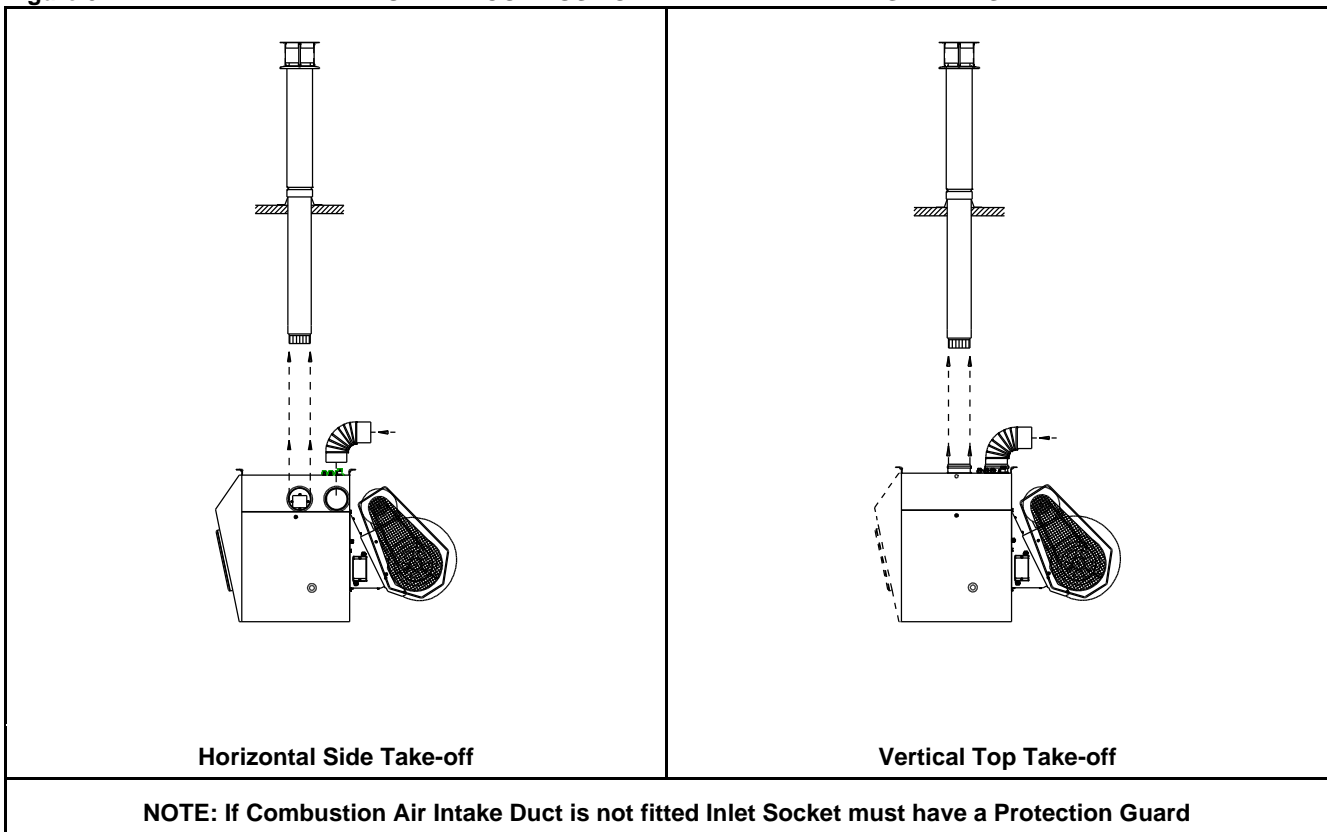

SECTION 5. GAS CONNECTION

- 5.1 Connection to a gas service may only be carried by suitably qualified persons. The gas installation must comply with the rules in force using materials appropriate for gas service installations.
- 5.2 Check that the gas category is in accordance with the data described on the air heater.
- 5.3 An adequate gas supply sized to provide the dynamic pressure for the volume required by the air heater(s) is essential to maintain the nominal heat input.
- 5.4 A 90° action gas service tap and, to facilitate servicing, a disconnect union fitting must be provided adjacent to the appliance, see fig. 6.
- 5.5 Ensure that a gas service includes a filter and has been tested and purged in accordance with prescribed practice prior to commissioning and taking the air heater into service.

Fig. 6 GAS CONNECTION DETAIL

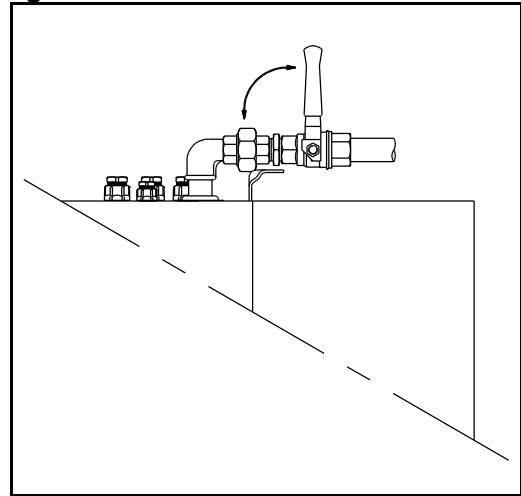

WARNING: NEVER use a FLAME to test for GAS Soundness !!!

SECTION 6. ELECTRICAL CONNECTION

- 6.1 The Electrical installation may only be carried out by suitably qualified persons observing the rules in force.
- 6.2 Check that the electrical specification is in accordance with the specified data on the air heater. A unique appliance wiring diagram is supplied as a separate document attached to this one, plus an additional copy is attached to the air heater.
- 6.3 These appliances **must** be earthed.
- 6.4 A separate electrical isolator for each heater must be provided adjacent to the appliance. The isolator must have a contact separation of at least 3.0 mm on all poles.
- 6.5 Ancillary controls are required to provide timed heat cycles, room comfort temperature level, frost protection, override air circulation etc. These are not included with the appliance and should be ordered separately.
- 6.6 Ensure when planning the external appliance control circuitry, that power will be supplied at all times to the air heater, even when it is control switched in the 'heat-off' mode. This is necessary to ensure that the fan can operate independent of the heating control. Therefore, **Never** incorporate automatic controls that electrically isolate the appliance.

NOTE: EURO.T AIR HEATERS ARE SUPPLIED WITH EXTERNAL CONTROL CIRCUITS BRIDGED. THE AIR HEATER/S WILL OPERATE CONTINUOUSLY UNLESS THESE ARE REMOVED AND TIME AND TEMPERATURE CONTROLS SUBSTITUTED FOR THEM

- 6.7 The centrifugal blowers fitted to Euro-T..B series air heaters are of the forward curved type therefore, the speed setting for the static pressure imposed by the air distribution system will govern the motor loading. All Euro-T air heaters leave the factory with the drives set to the specified conditions of the appliance. Table 5 provides the motor characteristics for the various sizes .
- 6.8 Refer to section 7 to learn how to carry out adjustments necessary to alter the fan speed and motor load factors.

Table 5 Maximum motor load ratings

Motor rating	kW	0.18	0.25	0.37	0.55			0.75			1.1		1.5	
Phase	~	1	1	1	1	3	3	1	3	3	3	3	3	3
Voltage	V	230	230	230	230	230	400	230	230	400	230	400	230	400
Load rating	A	2.3	2.3	2.8	3.9	2.4	1.4	4.7	3.1	1.8	4.5	2.6	5.0	2.9

SECTION 7. COMMISSIONING, LIGHTING AND OPERATION

COMMISSIONING

7.1 Normally Reznor Euro-T air heaters do not require commissioning. Final testing after production ensures that: **if installation has been carried out strictly in accordance with this document**, the appliance is ready to be taken into service.

7.2 Checks to ensure;

- earth continuity
- resistance to earth
- phase supply to correct terminals
- current rating and fuse value
- correct supply gas pressure
- correct burner gas pressure
- satisfactory & smooth ignition
- flue system is evacuating the products of combustion to outdoor atmosphere. must be made.

7.3 In addition to the above requirements checks to ensure that the fan performance and motor load factors are correct for the application and in accordance with the appliance data plate.

7.4 Drives general and adjustments

7.4.1 The drive assembly of Euro-T..B air heaters is guard protected to class IP20. Adjustment may be necessary to set the fan duty for the static pressure and motor load requirements. It is necessary to remove the guards prior to making adjustments. Before commencing work on the fan assembly:

- Set external controls to off or their lowest setting.
- Turn **OFF** the gas supply to the air heater.
- Switch **OFF** the electricity supply to the air heater after the air circulating fan has stopped.
- Remove protection guards as necessary and carry out adjustments as appropriate.
- Before placing the appliance back into service or switching the fan on ensure that all protection guards are replaced and secured.

N.B. Rotational speed checks should be carried out using an infra red tachometer or stroboscope.

7.4.2 Adjusting the fan speed can be carried out by altering the diameter of the adjustable drive pulley.

- Loosen the belt tensioning device and remove the drive belt.
- Refer to figure 7 and note that the outer section of the drive pulley is secured by a hexagon socket grub screw to a flat on the pulley hub, this is positioned by loosening the grub screw sufficiently to enable the pulley to be either opened or closed by turning it on the thread on which it is engaged.
- It should be noted that one complete turn of the pulley half is equal to approximately 8% of the fan speed. Closing the pulley increases the speed and opening decreases the speed.
- after making speed adjustments tension belt in accordance with the dimensions given in figure 7 and check pulley alignment to ensure the belt runs correctly.

N.B. Always ensure that the pulley is tightened onto a flat of the hub before switching on the fan, even when testing a reset condition.

Figure 7 Pulley & belt adjustment

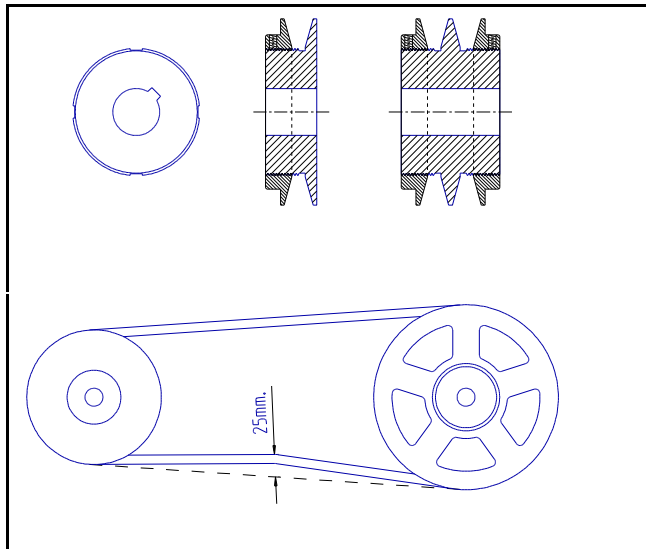

7.4.3 **Caution!**

Opening the pulley too far will cause the belt to touch the bottom of the vee groove resulting in greatly reduced belt life and loss of grip.

7.4.4 If the amount of adjustment is not achieved with the range obtainable with the pulleys fitted, it will be necessary to change the driven pulley fitted on the blower and possibly the size of the drive vee belt. **After adjustment ensure the motor load rating is not exceeded!**

7.5 LIGHTING

- Ensure that air discharge louvres are set to open.
- Turn on gas supply.
- Switch on electrical supply.
- Set time switch (if fitted) to an 'ON' cycle.
- Set room thermostat to 'ON' position.
- If reset button on heater and/or on remote control (if fitted) glows, press reset button.
- Heater should now light automatically within 2 minutes. after a further period the air circulation fan should run, (see also below: "operation" point 6).
- For a new installation or if the appliance has been turned off for an extended period then up to 3 attempts to light the air heater may be necessary. If the heater still does not light, consult the fault finding guide section 9.

7.6 OPERATION

Refer to figure 12.

- 7.6.1 At the dictates of the external controls, an electrical circuit is made and the combustion air fan ("venter") runs.
- 7.6.2 Provided adequate air flow is proved, the fan will continue to run approximately 30 sec. (pre-purge period).
- 7.6.3 Euro-T air heaters employ the direct burner ignition principle. A hot surface igniter will glow for ± 15 seconds, after which time the gas valve(s) will open and the burner will be lit.
- 7.6.4 If the burner has not lit within 5 seconds, the electronic flame relay will switch off and lockout will occur. This will cause the signal lamp to glow within the reset push-button on the appliance and/or on a remote control (if fitted). After 10 seconds the reset button on the appliance or the remote control can be activated in order to reset and restart the appliance.
- 7.6.5 Flame failure protection is by the ionisation principle i.e. the ability of a suitable flame to pass an electrical current between the igniter and the earthed burner assembly. To check the flame current is adequate, remove jumper between terminal 17 and 18 on the automatic burner

control, connect a DC micro ammeter between the terminals. Ionisation current should be $\geq 2\mu\text{A}$. **Note:** The terminals carry mains voltage when energised.

- 7.6.6 Simultaneously to the ignition circuit and gas valve circuit being energised, electrical power is supplied to an anticipator within the air circulation thermal fan control. The air circulation fan will start after about 2 minutes and warm air at a temperature of approximately 40°C is now discharged from the appliance.
- 7.6.7 In the event of the combustion air volume falling below a safe level, the burner will be extinguished a re-start cycle will commence after adequate combustion air volume has been restored.
- 7.6.8 If the burner flame is extinguished for any reason during a run cycle, an automatic attempt for re-ignition will take place, if the burner does not relight then safety shut down and lockout will occur. Manual intervention to reset is necessary to put the air heater back into service.
- 7.6.9 In the event of overheating for any reason, thermally activated fail safe overheat controls operate to switch off the burner. The first control (LC1) switches off the burner and upon its cooling, automatically resets and the lighting sequence starts automatically. The second control (LC3) which operates at a higher temperature setting, will switch off the burner and itself set to a lockout condition which also requires manual intervention to reset to restore the heater to operational condition. A cooling time of ± 1 minute is necessary before thermal re-setting can be carried out
- 7.6.10 When the set temperature or the heating time period has been reached, electrical power to the burner relay will be switched off and the burner will extinguish. The air fan will continue to run until the heat exchanger has been cooled down to a safe level.
- 7.6.11 To turn off the air heater for a short period,
a. turn room thermostat to lowest setting.

To relight reset thermostat.

For prolonged period;
a. turn room thermostat to low setting,
b. turn gas supply to the appliance off.
c. switch off electricity supply to the air heater **after air circulation fan has stopped.**

To relight follow lighting instructions.
- 7.6.12 The gas service tap must only be operated in emergencies, for servicing or prolonged periods of shutdown of the air heater.

SECTION 8. MAINTENANCE

8.1 General

Before commencing servicing, turn off the main gas supply and switch off the main electricity supply **after the air circulation fan has stopped.**

8.2 It is recommended that maintenance is carried out at least once a year. More frequent servicing may be required dependent upon the environmental circumstances where the air heater is installed. Regular inspection is necessary, especially in dirty areas, to assess the servicing frequency.

8.3 Check condition and security of flue and combustion air system.

8.4 Check for security and worthiness of the suspension or mounting system.

8.5 To gain access to the controls and flue gas fan assembly.

8.5.1 For appliances fitted with vertical flue systems, refer to figure 8. Follow the four step procedure:

- 1. Unlatch cam fastener (key 1) ¼ turn counter clockwise on controls compartment access panel.
- 2. Remove access panel (key 2).
- 3. Unscrew retaining screw (key 4) at top of upper cover panel (key 3).
- 4. Upper panel can now be removed by pushing upwards 2 cm to disengage panel retaining lugs and then lifted away.
- 5. The flue installation should include a service access section adjacent to the connection socket allowing access to the top of the flue fan. In the event that the fan housing assembly requires removal i.e. for replacement, then it is necessary to remove that section to access the 4 securing screws that fasten the fan housing through the top of the appliance. All controls, electrical and flue gas components are now accessible.

8.5.2 For appliances fitted with horizontal flue systems: follow steps 1 & 2 above and then;

- 1. Disconnect flue and combustion air inlet pipes at the section provided. Ensure that the pipes will remain supported when disconnection has been made.
- 2. Remove 4 sheet metal screws securing the venter fan to the upper cover panel.
- 3. Follow steps 3 & 4 8.5.1 above.

8.5.3 To replace reverse order above as appropriate.

8.6 If it is necessary to remove the cabinet top panel to gain access to the flue products collector box or the top of the heat exchanger, it is necessary to:

- 1. Isolate and disconnect the electrical and external controls wiring that passes through the panel.
- 2. Isolate and disconnect the gas service to the air heater.
- 3. Remove all of the sheet metal screws that secure the top panel to the appliance and remove panel as required.

8.7 Remove all dust and dirt from the combustion air fan (venter) see fig. 10 If dismantling venter observe critical dimensions before reassembly.

8.8 Check that air circulating fan guard is undamaged and secure.

8.9 Check security of the fan blade and fan motor. **Note:** The fan motor is lubricated for life and does not require lubrication.

8.10 Inspect hot surface igniter fig.9 replace if in doubt about its condition. **Note: The Igniter device is fragile, therefore, handle carefully**

8.11 Inspect and clean the burner assembly, refer to fig.11

8.12 Inspect heat exchanger and clean as necessary. This can only be done after removing the burner assembly.

8.13 After removal of burner assembly, each element of the heat exchanger can be cleaned by use of a soft brush and compressed air. Clean both inside and the outside surfaces.

8.14 Clean burners and gas jets with soft brush and compressed air. To prevent damage, do not use hard objects for cleaning the gas injectors

8.15 If anchor lines of service panels are removed during servicing, they **must** be refitted upon completion of the service.

8.16 **Upon completion of any service work it is necessary to re-commission the appliance in accordance with the step procedure described in section 7.7.2 of this document.**

Figure 8. SERVICE ACCESS KEYS

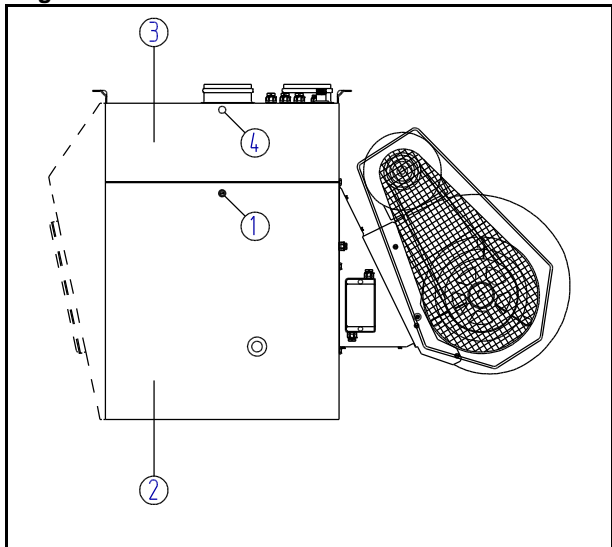

Figure 9. IGNITER ASSEMBLY

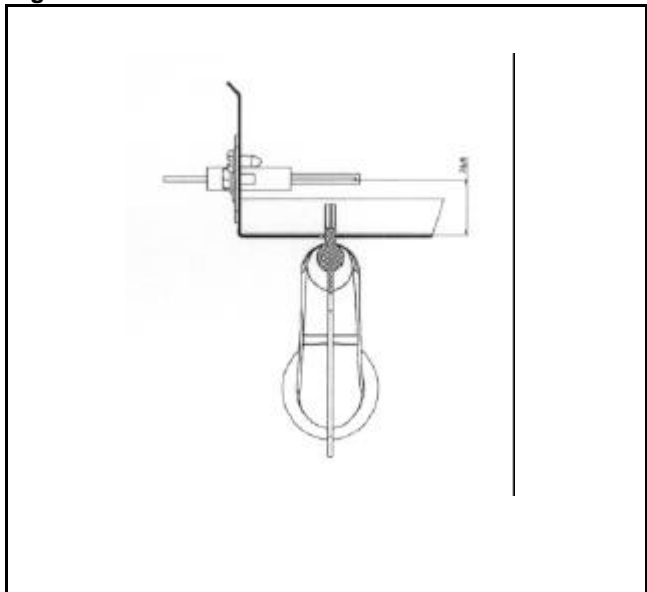
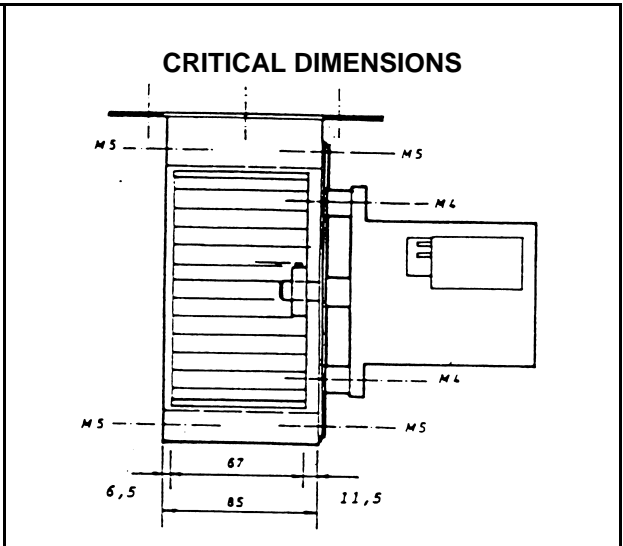
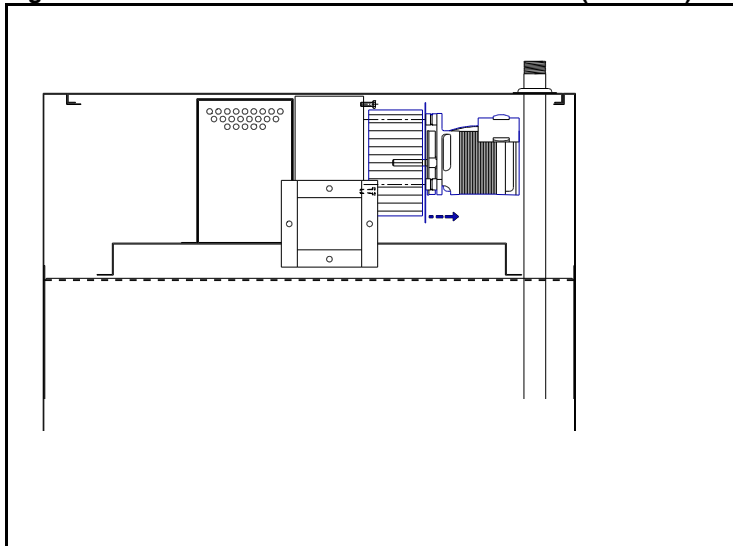

Figure 10. REMOVAL OF COMBUSTION AIR FAN (VENTER) MOTOR FAN IMPELLER ASSEMBLY



- 8.17 TO REMOVE COMBUSTION AIR FAN:**
1. Disconnect electrical connections to fan motor.
 2. Remove motor and venter wheel (3 screws).
 3. Withdraw motor/impeller assembly sideways.

4. Clean venter housing.
5. Check, clean or replace motor and/or venter wheel.
6. Replace in reversed order after checking critical dimensions (fig. 10)

Figure 11. REMOVAL OF BURNER ASSEMBLY

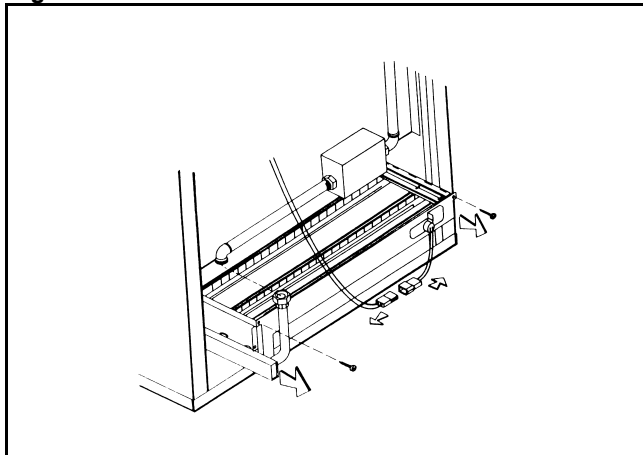

TO REMOVE BURNER ASSEMBLY:

1. Turn off the main gas supply.
2. Switch off the main electricity supply **after air circulation fan has stopped.**
3. Open service panel fig.8.
4. Disconnect wires of igniter.
5. Disconnect union fittings between gas valve(s) and burner.
6. Unscrew fixing screws of burner and pull forward burner assembly on it's slide rails.
7. Replace in reversed order

Figure. 12

COMPONENT PARTS LAY OUT

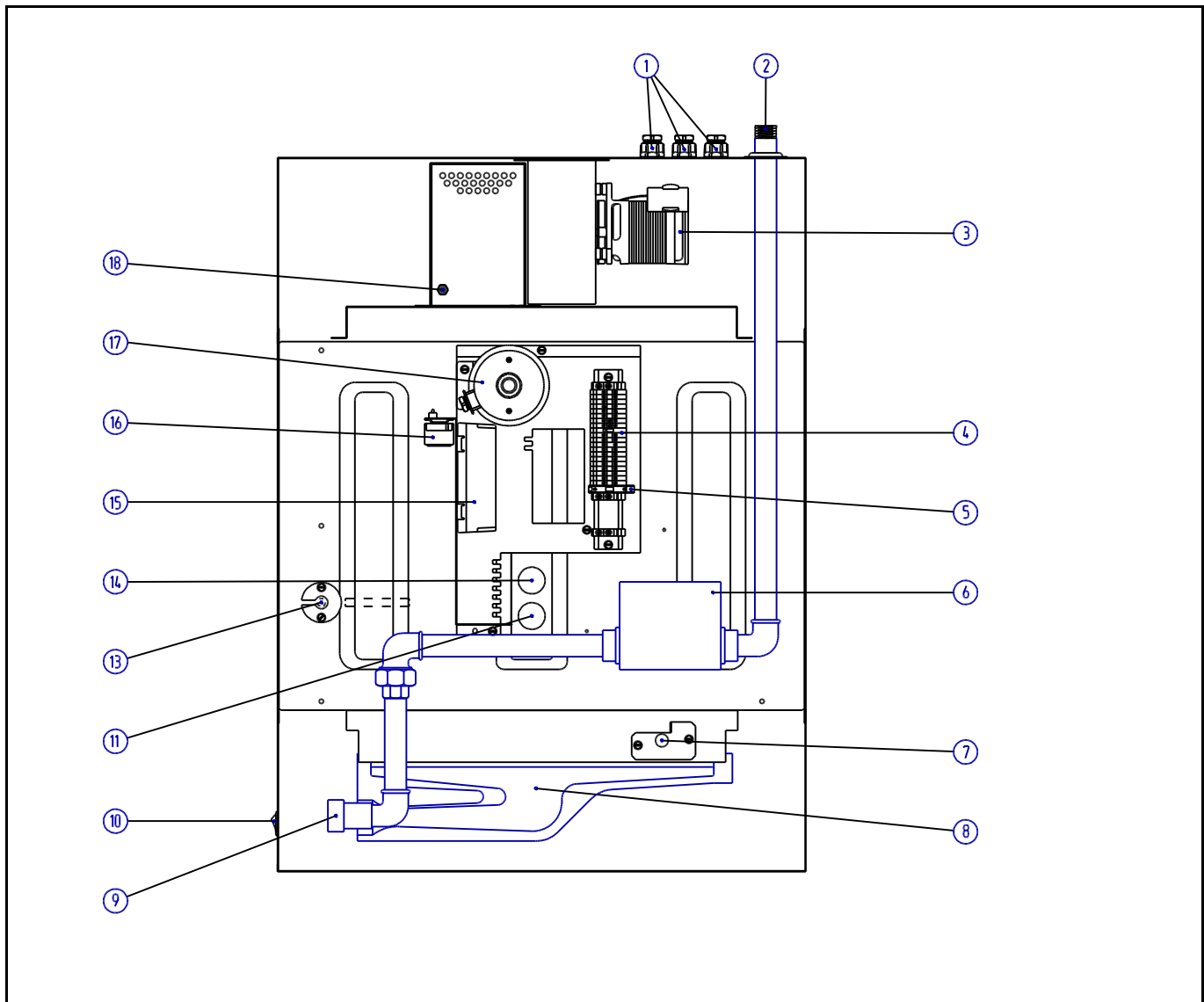

Legend:

- | | |
|---|--|
| <ul style="list-style-type: none"> 1. Cable entry all electrical connections 2. Gas connection 3/4" (not supply line size) 3. Combustion air fan with motor 4. Terminals for all electrical connections 5. Fuse 6. Double gas valve with pressure regulator 7. Hot surface igniter 8. Burner tray with burner ribbons 9. Manifold with injectors and pressure nipple | <ul style="list-style-type: none"> 10. Reset button with indicator for burner relay lock-out 11. Fan thermostat (FCR) 12. Not used for UK! 13. Bulb of thermal overhear and seal/grip (LC3) 14. Thermal overhear control (LC1) 15. Burner relay 16. Thermal overhear control (LC3) 17. Differential switch 18. Differential pressure reference point nipple |
|---|--|

THE APPLIANCE WILL ONLY OPERATE WITH ALL PANELS CORRECTLY FITTED !!

SECTION 9. FAULT FINDING

9.1 Burner does not ignite

- Thermostat set too low or time switch not correctly set; no power to terminals 2 and 5.
- Fuse F3 has blown; no power to terminal 2 and LC3.
- Reference tube to differential air pressure switch S3 is not airtight or blocked.
- Faulty differential air pressure switch S3; no power to terminals 2 and 13.
- Insufficient differential pressure in flue pipe system; Flue blocked or too long.
- Burner relay in lockout (point 2 below) or faulty.
- Faulty combustion air fan M3 (venter).
- Faulty limit control LC1; no power to terminal 2 and LC1.
- Overheat control LC3 in lockout; no power to terminal 2 and LC3; Reset manually.

9.2 Flame relay in lockout

- Air in gas service; purge.
- Low gas pressure.
- Faulty hot surface igniter.
- Faulty differential air pressure switch.
- Gas valve does not open; no power to terminals 2 and 7.
- Insufficient ionisation flame current; ionisation current $\geq 2\mu\text{A}$.
- Incorrect wiring of mains input line, neutral, earth.

9.3. Combustion air fan (venter) does not start

- Faulty motor or capacitor.
- Faulty burner relay.
- Differential air pressure switch S3 still in normal run position no change-over.
- Faulty fuse F3.

9.4 Differential air pressure switch switches burner off

- Switch-point should be; ON 1,02 mbar, OFF 0,94 mbar, except type..25/26: ON 0,76 mbar, OFF 0,69 mbar.
- No differential pressure in flue gas system; check flue and air inlet.
- Faulty combustion air fan or capacitor.

9.5 Appliance does not provide sufficient warm air

- Check gas inlet pressure.
- Check burner pressure.
- Gas filter (if fitted) dirty or blocked.
- Limit control (LC1) switches burner off (see 9.6).
- Differential pressure switches relay off (see 9.4).

9.6 Limit control LC1 switches burner off

- Switch temperature 51,5°C, ..55/56....95/96 top connection: 63°C.
- Insufficient air flow.
- Vertical and horizontal louvres set in closed position.
- Burner overload, check burner and inlet gas pressure.
- Fan control switch faulty
- Check fan rotational direction.
- Air temperature at fan inlet too high; T max. 30°C (see 9.6).
- Thermal contact in fan motor switches off intermittently.

9.7 Limit control LC3 switches

- Switch temperature 96°C (+0/-5).
- Check location and security of capillary and probe.
- Air discharge temperature too high (see 9.6).
- Faulty limit control LC1.
- Air fan stops immediately after burner is switched off; incorrect control/s wiring.
- Faulty fan control (FC).

9.8 Air fan does not start

- No power to terminals 2 and 11.
- Faulty fan control (FC).
- Faulty motor or capacitor.
- Thermal over-load in motor switching.

9.9 Fan starts and stops intermittently while burner is on.

- Faulty heat anticipator (FCR) in fan switch.
- Thermal over-load in motor switching.
- Inlet ambient air temperature too low; T min. $<5^{\circ}\text{C}$.; will correct as space temperature rises.
- Faulty wiring connection; loose terminals!

SECTION 10. SPARE PARTS LIST

10.1 GAS SECTION

DESCRIPTION	PART NUMBER	MFGS.REF.	APPLICATION
Gas valve single stage burners	03 25250	SIT 830 Tandem	2..25/26 - 2..35/36
Gas valve single stage burners	03 25136	H'well VR4601AB	2..45/46 - 2..95/96
Gas valve two stage burners	03 35136	H'well VR4601BP	Two stage options

10.2 ELECTRICAL SECTION

DESCRIPTION	PART NUMBER	MFGS.REF.	APPLICATION
Thermal fan control	03 25166	TOD29T12 (250V)	All
Thermal over-heat control (limit) LC1	03 24970	TOD60T11	All
Thermal over-heat control LC3	03 24959	limit 96°C	All
Combustion fan motor + wheel assy.	36 29090	Drouard-tec CP 78	All
Combustion circuit pressure switch	30 30607 68	Honeywell C6055 FH1144	Models < 2.35/36
Combustion circuit pressure switch	30 60607 9435	Honeywell C6055 FH1193	Models > 2.35/36
Automatic burner control	03 25317	Honeywell S4570LS	All
Hot surface ignition device assembly	05 25217	Norton 240V	All
Two pole relay K1.2	30 61738 240V	Omron G7L2A	All two stage burners
Wiring harness for burner control	06 41531 HGC	----	All
Wiring connector for igniter device	06 41531 HGC	----	All
Wiring harness for two stage burners	06 41621	----	All
Wiring terminals	06 41635	Entrelec	All

10.3 AIR HANDLING SECTION

DESCRIPTION	PART NUMBER	MFGS. REF.	APPLICATION
Centrifugal blower	02 25751 01	BDC 241-241	2..25/26
Centrifugal blower	02 25752 01	BDC 270-270	2..30/31
Centrifugal blower	02 25753 01	BDC 321-321	2..35/36 thru 2..55/56
Centrifugal blower	02 25754 01	BPC 270-270	2..75/76
Centrifugal blower	02 25756 01	BPC 321-321	2..95/96
Fan motors	Specify: kW rating - phase - shaft size when ordering		

10.4 MISCELLANEOUS

DESCRIPTION	PART NUMBER	MFGS. REF.	APPLICATION
Combustion air fan impeller	02 25730	Punker	All
Suspension sockets 1" BSP (R1)	35 20003 2000	AI	Options
Sampling pressure test point	07 25811 02	M8	All
Silicon tubing	06 20224 cm	f 5-8 mm x 1.0 m	All
Combustion fan assembly gasket	11 44696	---	All
Capillary seal plate assembly	08 07727	---	All

SECTION 11. GAS CONVERSION

- 11.1 This air heater is designed to operate on natural, propane or butane gas and will be supplied as ordered for the gas type specified. In the event it is required to convert to a different gas type to that which has been supplied, conversion of the gas burner must be carried out.
- 11.2 A Reznor approved conversion kit to suit the appropriate gas type must be used.
- 11.3 In addition to changing the burner injectors, and adjusting the gas pressure, sealing a governor or fitting a blanking plate it is necessary to fix over stickers as supplied with the conversion kit of parts.
- 11.4 After conversion re-commission appliance according to section 7 of this document.

Figure. 13 BURNER AIR SHUTTER AND SETTING DIMENSION for all GASES UK & IE

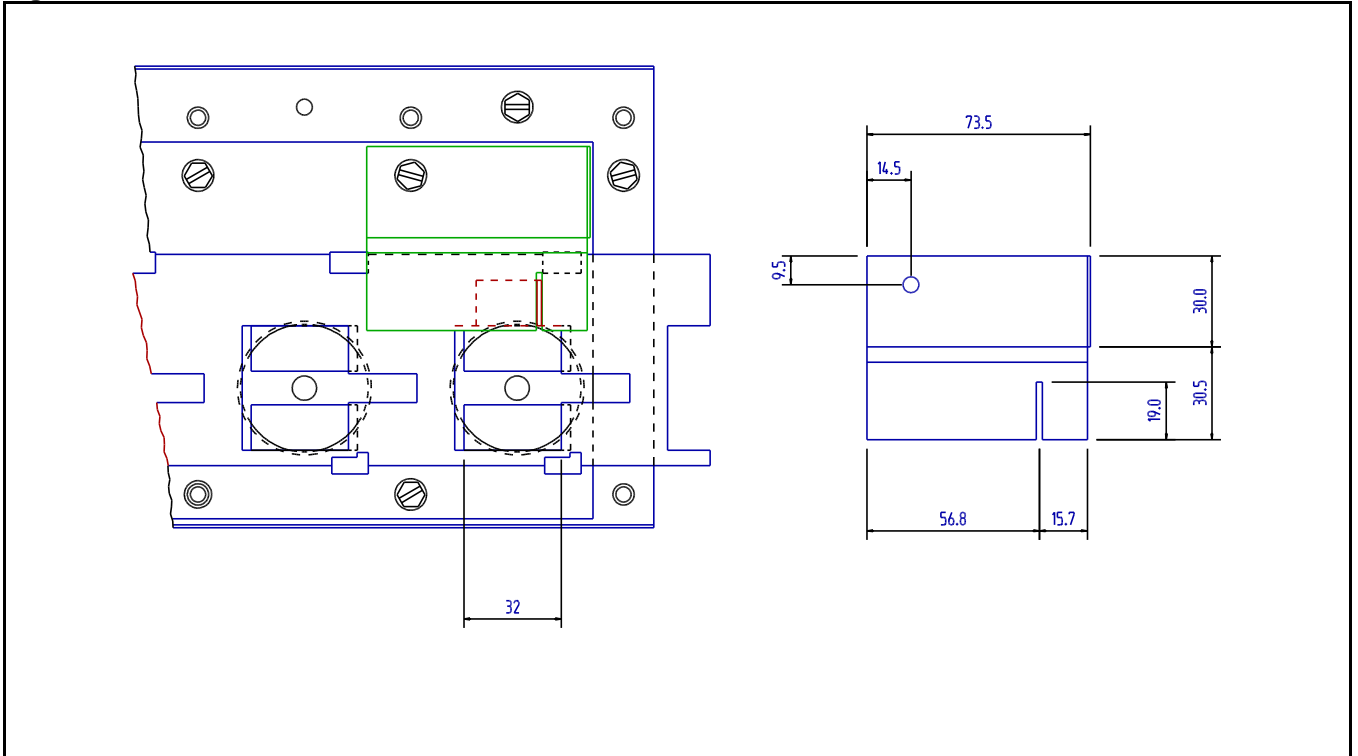

SECTION 12. HEALTH & SAFETY STATEMENT

Health and Safety Information for the Installer and Commissioning-Service Engineer

12.1 General

Under the Consumer Protection Act 1987 and Section 6 of the Health and Safety at Work Act 1974 we hereby provide the following information on substances hazardous to health.
Product range reference Euro.T Series air heaters.

12.2 Cautionary note

During first firing some smoking may occur, this is due to the burning off of protective/lubricating oils used during appliance production. Most of this will have been removed during the production testing process. It is a wise precaution to ensure that adequate ventilation is provided during the initial firing and throughout the commissioning period, this is particularly important if the discharge air is to blow into a confined space. This smoking does not constitute a poison hazard.

12.3 Declaration

Reznor products contain no asbestos; copper is not employed in gas carrying components; solder which has a melting point below 450°C is not used; paints for corrosion protection and decoration are heat cured and contain no lead.

12.3.1 The above appliances meet the Electrical Safety requirements of EN60 335 Pt 1 1988.

12.4 Miscellaneous

Small quantities of adhesives and sealants used in the product are dried and cured and present no known hazard.

12.5 Insulation and Seals.

Material: Alumino - silicon fibre

Description: Tapes

Known hazards: Some people can suffer reddening and itching of the skin. Fibre entry into the eyes will cause foreign body irritation.
Inhalation will cause irritation to the respiratory tract.

Precautions: Wear protective gloves when handling. People with a history of skin complaints may be susceptible to irritation.
Dust levels are only likely when the material is abraded.

In general normal handling and use for this purpose will not present discomfort. Follow good hygiene practices, wash hands before consuming food or using the toilet.

First Aid: Medical attention must be sought following eye contact or prolonged reddening of the skin.

12.6 Thermostat.(Thermal overheat (limit) control LC3)

Material: Illuminating Kerosene.

Description: Sealed phial contains a small quantity in liquid form.

Recognition: Colourless liquid, paraffin oil/petroleum hydrocarbon odour.

Characteristics: Non-corrosive, flammable with no poisonous reference-CH poison Class 3

Precautions: Avoid handling. This product can irritate and de-fat the skin. Prolonged contact may cause dermatitis. Avoid breathing vapour. Avoid eye contact. Do not ingest.

First Aid: Skin. Wash thoroughly with soap and water.

Eyes. Rinse immediately with copious amounts of clean water.

Ingestion: Seek medical advice.

NOTE: If skin irritation persists seek medical advice.

12.7 Electrolytic Capacitor

Two types are used by random selection:

Recognition: 1.Plastic enclosure 2.Aluminium enclosure

Material: Contained liquid electrolyte

Known hazards: Electric shock possible if charged.

Precautions: Discharge to ground/earth. Do not incinerate.

First Aid: Treat for electric shock if affected.

END OF HEALTH AND SAFETY STATEMENT

Reznor UK Ltd 08/01

SECTION 13. USER INSTRUCTIONS

OPERATING

How the air heater works:

Gas is burned by an atmospheric burner which fires into a heat exchanger. The gas burner is controlled by a double gas valve via an electronic burner control, which is actuated automatically via external controls i.e. a room thermostat and/or a time switch. The burner is ignited by a hot surface igniter. When the burner fires and warms the heat exchanger, the heat is sensed by a thermally actuated fan control which switches on the fan when the air temperature has reached its preset operating level. At the end of a heating cycle the burner is switched off, the air circulation fan will continue to run until the air heater has cooled to a safe condition. Thereafter the fan will remain off until the next cycle is initiated.

Safety:

1. Flame failure is detected by the hot surface igniter which is also the sensor and will immediately result in gas valve shut down.
2. Safety against overheating is assured by two overheat controls. The first is an automatic recycle control which protects against low air flow i.e. clogged air ways, fan failure etc. The second, which is set to a higher level than the first one, is a control which locks out and switches off the burner in the event of gross overheating for any reason. Manual intervention is necessary to reset this control device. Resetting of the automatic burner control may also be required.
3. The location of the air heater should be maintained at normal atmospheric pressure. Changes to the building after air heater installation, should have regard to the heating installation, i.e. structural changes causing excessive draughts from doors, windows etc. Other air handlers and installation of air extraction equipment which may cause a negative pressure environment, can seriously affect the operation of this type of air heater, especially if combustion air supply is not ducted.

To light the heater:

1. Turn on the gas supply to the air heater.
2. Switch on the electricity supply to the air heater.
3. Ensure time switch (if fitted) is set to a 'ON' cycle.
4. Adjust control/room thermostat to desired temperature.
5. Air heater will light automatically when the room thermostat calls for heat.
6. If the appliance does not light:
 - a) check that the burner control does not require resetting. An indicator light glows at the front panel of the appliance and on a remote control (if fitted). Reset by pushing light/button on appliance or the remote

control.

b) check if thermal overheat control requires resetting (see fig. 12 page 15 key 16).

7. If the thermal overheat control requires resetting and doing so restarts the air heater, wait until the appliance warms to thermal equilibrium, to ensure the overheat control does not lock out again. **If it does and the temperature near the heater is less than 30°C, then switch off the appliance and call for service.** If the temperature is over 30°C, take appropriate action to reduce the ambient temperature near the air heater.

Air circulation:

1. The space heating process is for air to be circulated through the appliance whereby it gains heat from a heat exchanger. The air is directly discharged into the space to be heated. The air is eventually re-circulated. Therefore it is very important that an unobstructed path for the circulation of the air will be maintained. This is particularly important if the air heater has been installed to blow through the wall between two rooms.
2. Sometimes the air circulation fan of the appliance is connected to a remote over-ride switch. This enables cool air to be used for circulation purposes when the air heater is not used for heating purposes e.g. in summer.

To use this feature:

 - a) switch ON electricity
 - b) switch ON manual override switch, this may be fitted as a feature on a remote composite control.

Maintenance:

1. Maintenance and service must only be carried out by appropriately qualified persons e.g. "Corgi" registered undertakings.
2. It is in your interest to ensure proper service and maintenance is carried out at a regular basis. Periods between service are dependent upon the local environment where the heater is installed. All gas appliances should be serviced at least once a year.
3. In case of any damage to the appliance, it must be shut down completely and checked by an appropriately qualified person. 4. In the event of difficulties in resolving any of these matters, please do not hesitate to contact Reznor or their official distributor.

Reznor[®] EURO-T 2000 S

**ONE OF A Reznor GENERATION OF CE MARKED GAS FIRED ENERGY
EFFICIENT AIR HEATERS**

**BEST USED WITH Reznor OPTIONAL ELECTRONIC CONTROL PANELS
SAVE ENERGY AND OPTIMISE THERMAL COMFORT**

**Reznor[®] Europe N.V.
J&M Sabbestraat 130
B8930 Menen
Belgium
Tel: +32(0)56 52 95 11
Fax: +32(0)56 52 95 33
e-mail: reznor_europe@tnb.com**

**Reznor UK Limited
Park Farm road
Folkestone
Kent
CT19 5DR
Tel: + 44 (0)303 259141
Fax: + 44 (0)303 850002
e-mail: sales@reznor.co.uk**