

GAS FIRED AIR HEATERS TYPE EURO-T 2000 D

Forced Convection Duct Appliances with
Automatic Ignition and Fanned Flues for use as:
Type B22 - C12 - C32

INSTALLATION COMMISSIONING SERVICING & USER INSTRUCTIONS

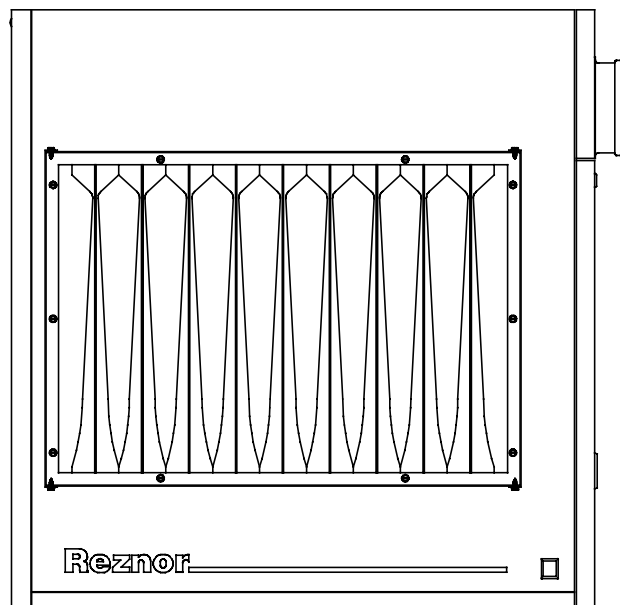

These appliances meet the following EC Directives:

Dir. CE 90/396/EEC:	GAD
Dir. CE 89/336/EEC:	EMC
Dir. CE 73/23/EEC:	LVD

PLEASE READ THIS DOCUMENT CAREFULLY BEFORE COMMENCING INSTALLATION AND LEAVE IT WITH THE USER OR ATTACHED TO THE APPLIANCE OR GAS SERVICE METER AFTER INSTALLATION.

INDEX

	<u>Page</u>
1. General	2
2. Technical data.....	3
3. Installing	6
4. Combustion, Air supply and flue system	9
5. Gas connection	11
6. Electrical connection	11
7. Commissioning, lighting and operation.....	12
8. Maintenance	13
9. Fault finding.....	16
10. Spare parts list	17
11. Gas conversion.....	18
12. Health and Safety Statement.....	19
13. User instructions	20

If optional equipment was ordered and supplied with this air heater, please refer to additional instructions for option(s).

SECTION 1. GENERAL

- | | |
|--|--|
| <p>1.1 Before installation, check that the appliance as described on the packaging label is in accordance with the correct type and model as specified on the data plate and complies with your customer order.</p> <p>1.2 After unpacking the appliance, leave it fastened to the wooden pallet until it has been suspended or until just before base mounting. This affords protection to the painted underside which is normally exposed to view after installation.</p> <p>1.3 Please read this document before commencing installation.</p> <p>1.4 These instructions are only valid for the country of use indicated on the appliance i.e.: GB - IE. If these symbols are not shown, it is necessary to obtain appropriate technical instructions which will provide information concerning the necessary modification of the appliance for the conditions of use in the country concerned. Such instructions may be obtained upon request from your supplier.</p> <p>1.5 Check that the local distribution conditions of electricity supply, type of gas and pressure, and adjustment of the appliance are compatible.</p> <p>1.6 When installed in Great Britain the total installation must comply with the requirements and recommendations of British Standard BS 6230 1991. "Installation of Gas Fired Forced Convection Air Heaters for Commercial and Industrial Space</p> | <p>Heating".</p> <p>The Installation must also be in accordance with the relevant requirements of "The Gas Safety (Installation and Use regulations) and (Amendment Regulations 1990)" and The "Building" and "Electrical Regulations" (in GB the IEE Regulations). The requirements of the "Local Building Standards Office", the premises "Insurance" undertaking and the "Fire Office" must also be observed.</p> <p>1.7 Unauthorized modification of this appliance or departure from use in the manner for which it was intended by the manufacturer or installation in a manner contrary to these instructions, may constitute a hazard and jeopardize all warranties. Deviations should only be carried out after formal consent has been obtained from the manufacturer.</p> <p>1.8 Ensure the environment in which the air heater will be installed will not create a hazard i.e. where excessive (volatile) dust, flammable or corrosive substances and/or vapors and combustible materials may be present.</p> <p>1.9 This appliance has been tested, and set according to the data plate before leaving the factory.</p> <p>1.10 These air heaters may be used as a gas fired heating module in an air handling appliance or in conjunction with a cooling packaged appliance. When applied in such manner the installation instructions contained in this document must be complied with as appropriate. The fitting within</p> |
|--|--|

another housing must take into account the gas fired appliance requirements of the appropriate CE standard, EN 1020 " Non-domestic gas-fired forced convection air heaters for space heating incorporating a fan to assist transportation of combustion air and/or flue gases" PrEN 1020 is in course of preparation and may be applied until the final document is published, (anticipated 1996)

1.11 The criteria recommended in this document regarding airflow pressures, temperature rise, firing rates and fitting methods must be strictly complied with, whether or not the appliance is used as a duct heater or as part of a multi-functional appliance, to ensure satisfactory operation.

SECTION 2. TECHNICAL DATA

Table 1. Appliance Data Standard Efficiency Models

EURO-T Standard Model #			2025D	2030D	2035D	2045D	2055D	2075D	2095D
EURO-T Low NO _x #			2525D	2530D	2535D	2545D	2555D	2575D	2595D
Gas category 'Cat.'			II _{2H3}						
Air supply and flue type			B22 - C12 - C32						
Heat input (Hs) 'On'	kW		28,8	35,2	42,7	49,9	63,2	86,5	115,4
Heat input (Hi) 'On'	kW		26,0	31,7	38,5	45,0	57,0	78,0	104,0
High heat output	kW		22,8	27,8	33,7	39,4	49,9	68,3	91,0
Number of jets			4	5	7		9	12	16
Jet size	natural gas	ø mm	2.4		2.2	2.4			
	propane/butane	ø mm	1.35		1.25	1.35			
Gas supply pressure 'P' ¹	natural gas	mbar	(GB) = 17.5 (IE) = 20.0						
	propane	mbar	37.0						
	butane	mbar	28.0						
Burner pressure ²	natural gas	mbar	8.50						
Gas consumption	natural gas ³	m ³ /h	2.74	3.36	4.04	4.76	6.02	8.30	11.00
	propane	kg/h	2.06	2.52	3.05	3.56	4.51	6.18	8.25
	butane	kg/h	2.10	2.60	3.12	3.64	4.61	6.31	8.42
Gas service connection (not supply line size)			Rc ¾						
Electrical supply			230/240V 1 N ~ 50Hz						
Electrical rating ⁴			180 W						
Protection grade			IP20						
Appliance weight net	kg		80	85	99		115	139	171
Appliance weight gross (shipping)	± kg		88	96	109		126	152	187

1 Maximum gas pressure at inlet to appliance = 50,0 mbar

2 All casing panels fitted, service door open

3 Natural gas G20, calorific heating value 10,5 kWh/m³ on Hs @ 15°C & 1013 mbar

Propane G31, calorific heating value 12,88 kWh/kg

Butane G30, calorific heating value 12,66 kWh/kg

4 Total electrical rating during the start-up period ± 30 seconds is increased by 130 W and is not included on the appliance data plate or in the above table

Table 2 Appliance Data Higher Efficiency Models

EURO-T Standard Model #		2026D	2031D	2036D	2046D	2056D	2076D	2096D
EURO-T Low NO _x Model #		2526D	2531D	2536D	2546D	2556D	2576D	2596D
High fire heat output	kW	23.7	28.8	35.0	41.0	51.9	71.0	94.6

Note: All other data as standard model

Table 3 Minimum air volumes for maximum temperature rise. Standard Appliance

Standard model Euro-T...		2025D	2030D	2035D	2045D	2055D	2075D	2095D
High efficiency model Euro-T...		2026D	2031D	2036D	2046D	2056D	2076D	2096D
Minimum air volume	m ³ /h	1800	2200	2660	3110	3940	5400	7190
Maximum temperature rise	_T K	37						

Table 4 Minimum air flows for maximum temperature rise. Low NO_x Models

Standard model Euro-T...		2525D	2530D	23535D	2545D	2555D	2575D	2595D
High efficiency model Euro-T...		2526D	2531D	2536D	2546D	2556D	2576D	2596D
Maximum air volume	m ³ /h	2080	2540	3080	3600	4555	6240	8300
Maximum temperature rise	_T K	32						

N.B. The maximum static pressure that may be applied to the Euto-T...D series is 800 Pa

Figure 1 Pressure loss for air flow passing Euro-T... D series air heaters

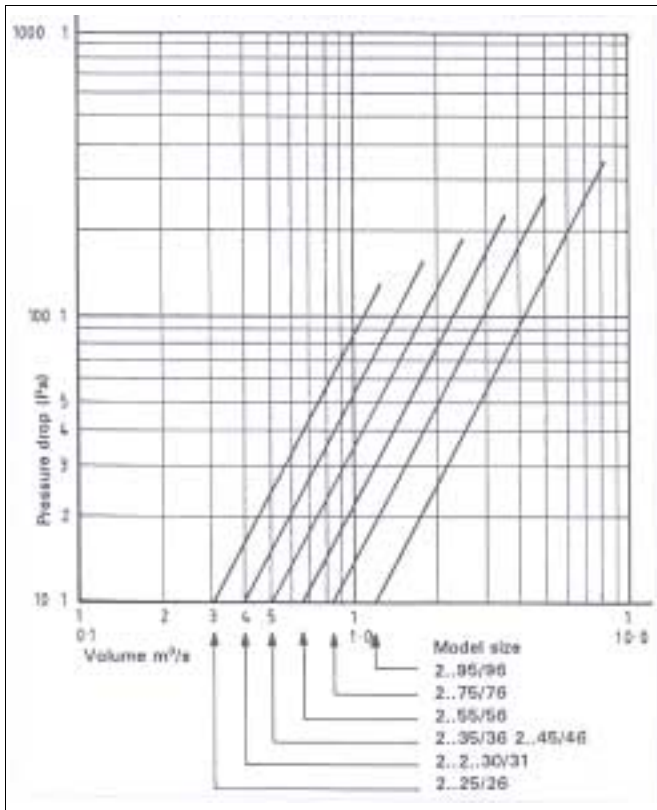

Figure 2. Combustion circuit Dew-point occurrence

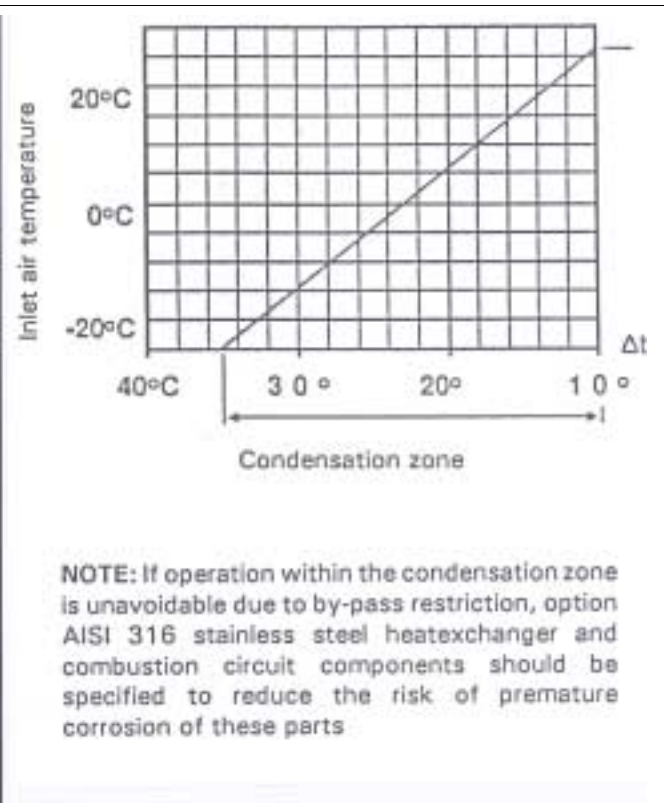

Figure 3.

DIMENSIONS

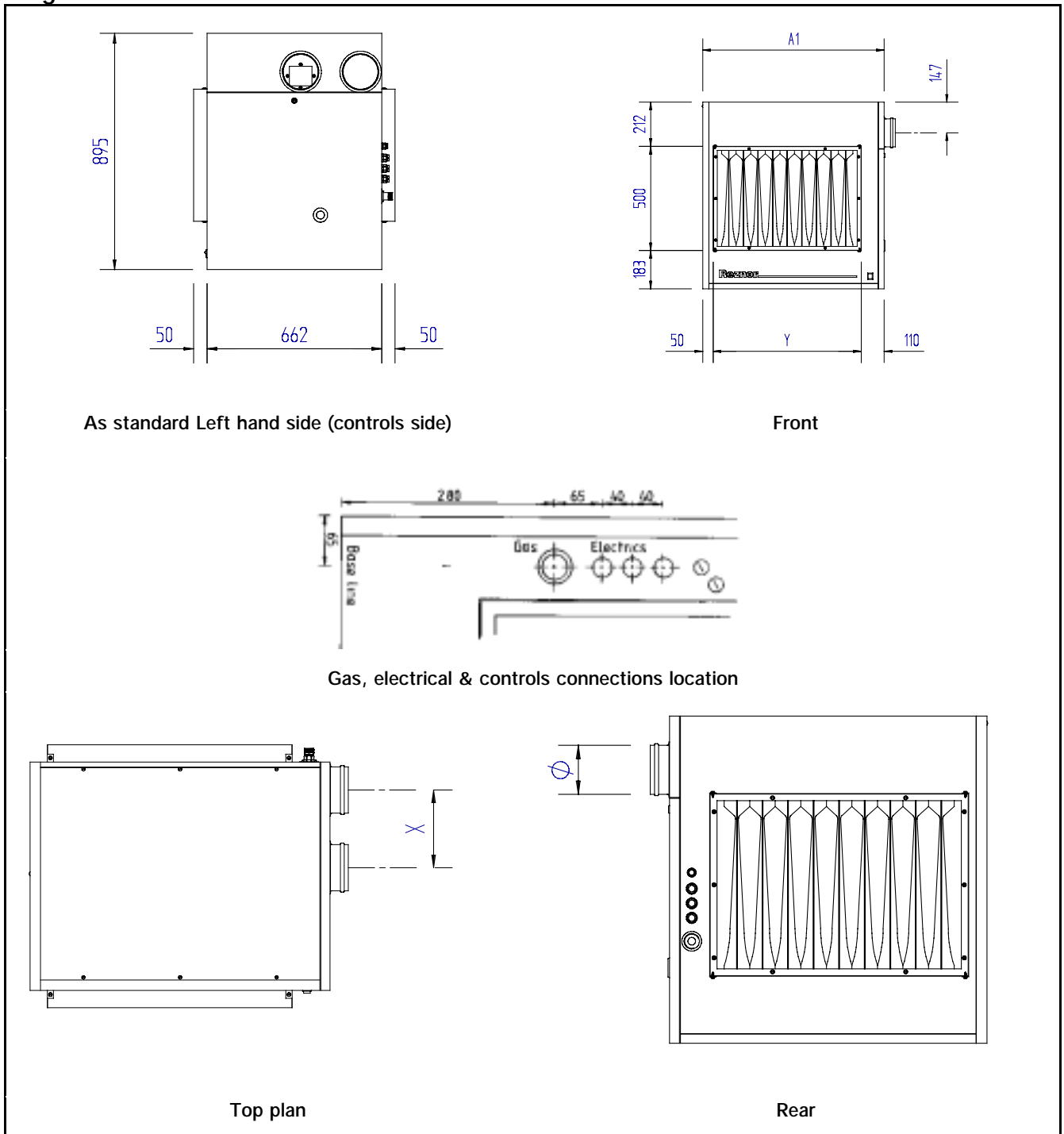

Table 5 Dimensions reference figure 3

Model	2..25	2..30	2..35	2..45	2..55	2..75	2..95
	2..26	2..31	2..36	2..46	2..56	2..76	2..96
Dimensions							
A1 Width overall	520	590	730		870	1080	1360
\varnothing Flue & combustion air intake socket internal \varnothing	102			132			
X Flue & combustion air intake socket centres	140			225			
Y Duct flange width front and back	360	620	570		710	920	1200

SECTION 3 INSTALLING

- 3.1 When installed as an in-line duct heater i.e. not fitted within an air handling appliance cabinet it is necessary to ensure that clearance is maintained around the appliance from combustible materials and for service access. The clearances necessary to ensure safety for combustibles is 150 mm on all sides. Service access should be allowed on the controls side of the appliance equal to the width of the air heater plus 200 mm, this distance allows for the removal of the burner tray assembly, necessary en servicing the appliance.
- 3.2 Ensure that the structural elements which will be used to suspend or support the appliance, are adequate to carry the weight of the appliance and its ancillary components i.e. flue system and any connected duct-work.
- 3.3 Ensure that the air heater is installed in a level plain.
- 3.4 If the air heater is to be base mounted in an open position then it must be secured to supporting devices.
- 3.5 4 suspension brackets with holes ϕ 10.5 mm are available as optional accessories. Use 10 mm ϕ rods for suspending the heater when using the Reznor options.
- 3.6 If the appliance is to be suspended or base mounted from cantilever brackets, specially designed wall brackets should be manufactured to suit the application respecting the clearances indicated in 3.1 above and the live load factors the appliance will impose.
- 3.7 After suspension, the air heater should be rigid so as to avoid placing a strain on the flue system, gas services electrical wiring and duct-work.
- 3.8 Euro-T.. Series D air heaters, wether or not they are installed within an air handling appliance may be installed in multiple form as illustrated in figure 4. In all instances the air flow passed through the appliance/s should not exceed the volumes required to ensure that dew point conditions within the combustion circuits/s as indicated in figure 3 do not occur.

By-passes should be constructed as necessary to ensure that the optimum temperature rises are met taking into account the pressure resistance of the air heater as indicated in figure 2.

When designing by-pass ducts ensure that the requirements for service access, flue and controls connections are maintained. An adjustable damper should be included within by-pass ducts to enable air flow pressure and volume to be adjusted after

installation.

When fitting Euro-T.. air heaters in a side by side configuration it is necessary to specify this requirement when ordering type D models. Whilst the air may be passed through the appliance from either end, provision for locating the thermal over-heat (limit) control device has to be made so that the air off side (the hottest side) is monitored for this purpose.

- 3.8 Figure 5. illustrates the recommended principle that should be used for the connection of ducts or air handling appliance element transitions. A positive seal must be maintained between the air circuit and the air heater, this is particularly important when the air heater is installed within an air handling cabinet. A neutral pressure zone around the appliance must be maintained to ensure that the atmospheric burner operates at all times at normal ambient pressure.

- 3.9 Figure 6 illustrates some of the situations to be avoided when connecting an air handler to the appliance. A rule of connecting a straight length of duct equal to 3 times an equivalent duct diameter onto the appliance should be maintained whenever possible. It is essential that an even air flow is distributed across the heat exchanger to ensure that the heat is scrubbed from all the exchanger elements thus preventing hot spots which will greatly reduce the working life of the air heater.

Always avoid installing a centrifugal fan so that the swirl effect created by the direction of rotation is counter directive. As well as the effect of uneven air flows, excessive loss of static pressure is created resulting in inefficiency of the fan.

Where it is necessary to connect a transition section as part of the connection then the degree of taper in any plain should not be greater than 15°. Abrupt transitions create excessive pressure drops and lead to uneven air distribution across the air heater.

Figure 4. Arrangements for applying multi-heater combinations

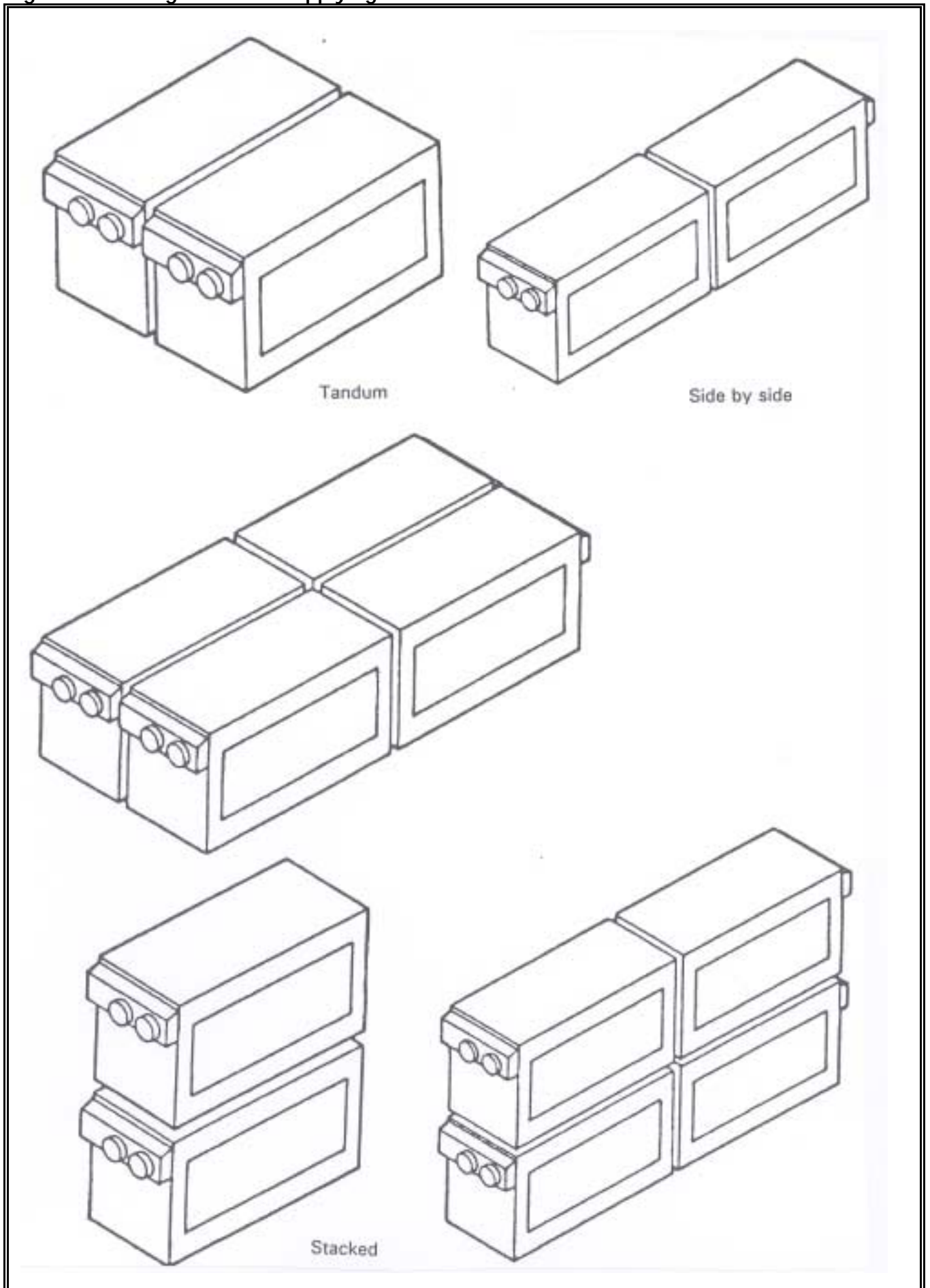
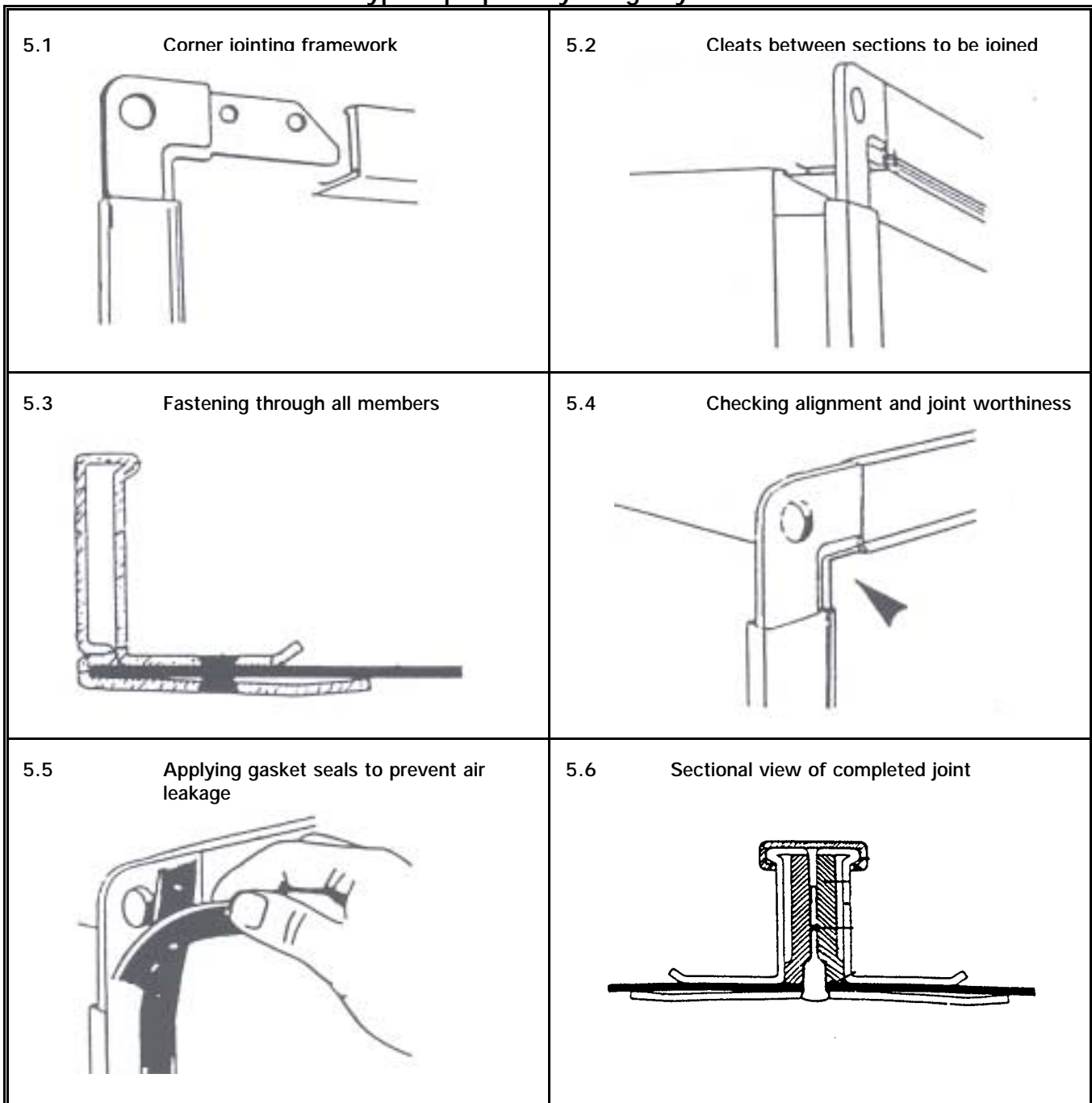

Figure 5 Recommended procedure and method for connection of ducts and transitions to the air heater

Typical proprietary flange system



Legend figure 5

- | | |
|---|---|
| 6.1 Cut and assemble flange into frame to suit opening | 6.4 Checking location after positioning |
| 6.2 Check dimensions and position on duct spigot | 6.5 Applying sealing gasket |
| 6.3 Ensuring flange is mated correctly before fastening | 6.6 Sectional view of completed joint |

Figure 6. Air handler application recommendations when elbows are used at appliance connection

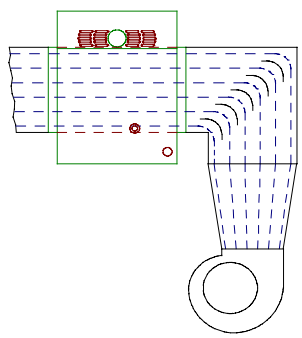
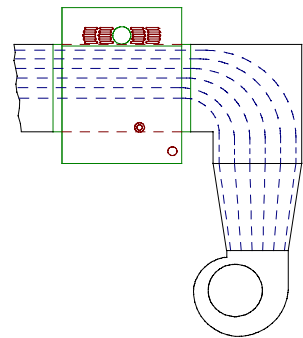
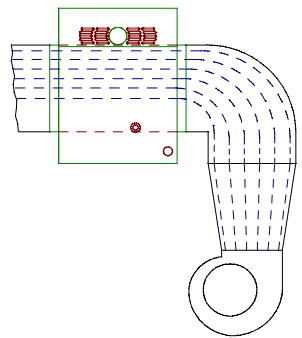
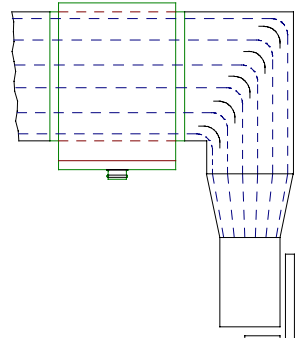
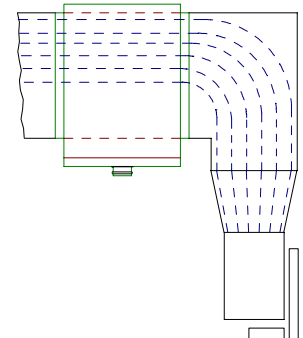
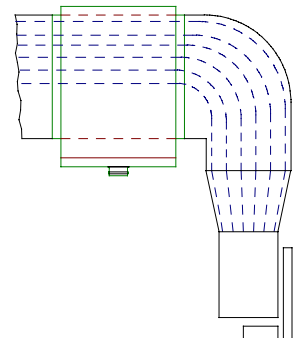
 <p>Elbow with turning vanes from below</p>	 <p>Square heel elbow from below</p>	 <p>Round heel elbow from below</p>
<p>GOOD</p>	<p>BAD</p>	<p>BAD</p>
 <p>Elbow with turning vanes from the side</p>	 <p>Square heel elbow from the side</p>	 <p>Round heel elbow from the side</p>
<p>GOOD</p>	<p>BAD</p>	<p>BAD</p>

SECTION 4. COMBUSTION AIR SUPPLY AND FLUE SYSTEM

- 4.1 Flue systems must comply with national and local regulations.
- 4.2 The products of combustion must be flued to outdoor atmosphere. Common flues for more than one appliance must **NOT** be used.
- 4.3 Combustion air should be taken from out-door atmosphere, this improves the operational efficiency of the heating system.
- 4.4 Flues and combustion air ducts where connected to the air heater must incorporate a disconnect section adjacent to the appliance to facilitate removal of the venter assembly for service and replacement purposes. The flue system must therefore, be supported independently. Where flue systems are taken through elements of air handling appliances then provision must be made to allow servicing of the flue gas fan assembly. this will entail fitting a special detachable transfer

section from the appliance flue and combustion air connection sockets to the outside of the appliance. The main flue should then respect the criteria outlined below.

- 4.5 Dimensions and allowances in suggested flueing and combustion air intake arrangements are based upon the use of smooth wall aluminium flue and combustion air ducts and fittings equipped with positive sealing gaskets.
- 4.6 **Type C Appliances**
 - 4.6.1 When using the concentric termination as fig. 7 arrangement, then only an approved system using Reznor specified components may be used. These items are manufactured from seamless aluminium with connection sockets fitted with silicone double edged seals, thus assuring, if the components are undamaged, leak free flue systems. **Important:** This type of flue/Combustion air intake system is regarded as an integral part of the air

heater therefore, departure from the methods of installing flues as published in this document is in breach of the EC Gas Appliance Directive.

4.6.2 Distances between the appliance and the concentric flue termination must not be greater than 9.0 m. When calculating the total length the following equivalent length data must be taken into account:

- 1 elbow @ 45° = 1 m
- 1 elbow @ 90° = 1,5 m.

4.7 Type B Appliances

4.7.1 If the air heater is to be installed as a B type appliance as fig.5 i.e. air for combustion to be taken from within the space to be heated, then it must be ensured that an adequate air supply for combustion and ventilation is provided, in accordance with the regulations and rules in force.

4.7.2 A horizontal distance between air heater and flue terminal and any combustion air intake duct, must not be in excess of 16 m.

Note: 2 Meters of vertical rise negates the resistance imposed by 1 meter of horizontal run.

Runs exceeding 16m may be subject to condensation forming within the flue for which provision for its removal must be made.

Equivalent lengths of flue fittings:

- Elbow @ 45° = 1 m
- Elbow @ 90° = 1,5 m.
- Flue terminal ≤ 3.0 m

4.7.3 To ensure that the allowable resistance is not exceeded in the case of horizontal runs of flues, a positive rise from the air heater of 1° i.e. 17 mm per metre is recommended.

4.7.4 If condensation is to be avoided, flues should not pass through cold areas or not be installed externally.

4.7.5 When mechanical ventilation is used, it shall be by mechanical inlet with either mechanical or natural extraction. Automatic means of control such as interlocks must be provided. The function of other ventilation systems in the zone where the air heater is installed must be taken into account. At no time should it be possible to create a negative pressure environment in the zone, this can lead to a hazardous situation, whereby the air heater flue may act as a pressure relief.

4.7.6 The terminal of a vertical flue must extend at least 1 m above a roof surface; flues must not be located where products of combustion might enter the building. Terminals must be fitted to all flues and ducted combustion air inlets. **The combustion air inlet if not used must be protected with an access guard.**

Figure 7. Flue systems for appliance types

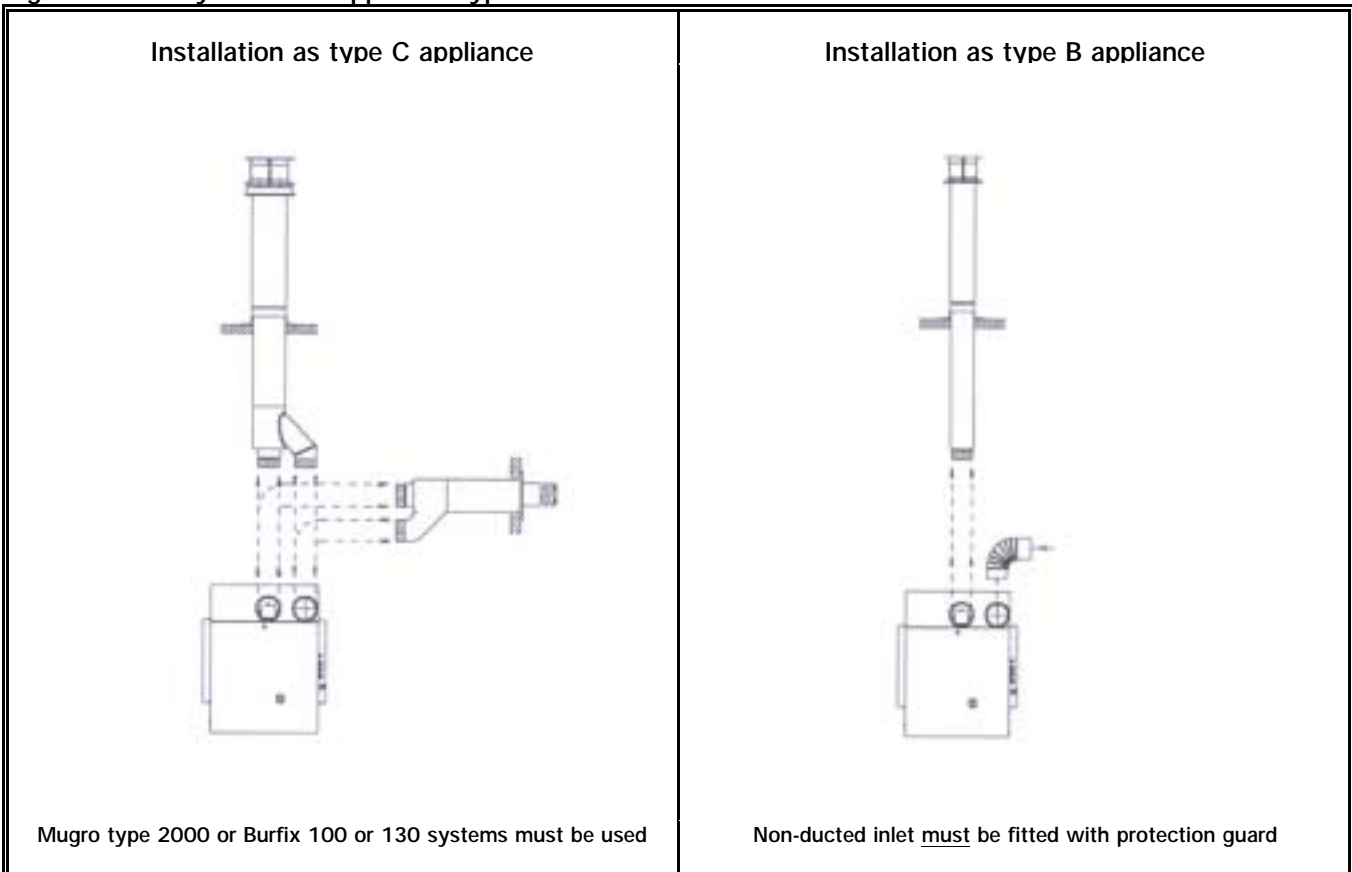

SECTION 5. GAS CONNECTION

- 5.1 Connection to a gas service may only be carried by suitably qualified persons. The gas installation must comply with the rules in force using materials appropriate for gas service installations.
- 5.2 Check that the gas category is in accordance with the data described on the air heater.
- 5.3 An adequate gas supply sized to provide the dynamic pressure for the volume required by the air heater(s) is essential to maintain the nominal heat input.
- 5.4 A 90° action gas service tap and, to facilitate servicing, a disconnect union fitting must be provided adjacent to the appliance, see fig. 8.
- 5.5 Ensure that a gas service includes a filter and has been tested and purged in accordance with prescribed practice prior to commissioning and taking the air heater into service.

Figure 8. Gas connection detail

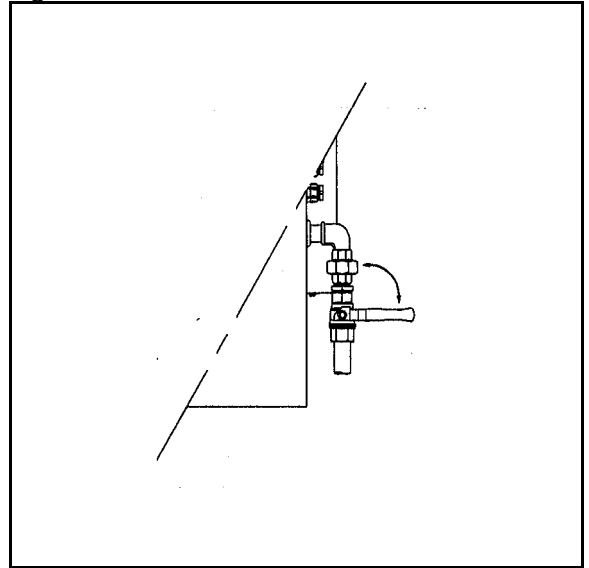

WARNING: NEVER use a FLAME to test for GAS Soundness !!!

SECTION 6. ELECTRICAL CONNECTION

- 6.1 The Electrical installation may only be carried out by suitably qualified persons observing the rules in force.
- 6.2 Check that the electrical specification is in accordance with the specified data on the air heater. A unique appliance wiring diagram is supplied as a separate document attached to this one plus a copy attached to the air heater
- 6.3 These appliances **must** be earthed.
- 6.4 A separate electrical isolator for each heater must be provided adjacent to the appliance. The isolator must have a contact separation of at least 3.0 mm on all poles.
- 6.5 Ancillary controls are required to provide timed heat cycles, room comfort temperature level, frost protection, override air circulation etc. These are not included with the appliance and should be ordered separately.
- 6.6 Ensure when planning the external appliance control circuitry, that power will be supplied at all times to the air heater, even when it is control switched in the 'heat-off' mode. This is necessary to ensure that the fan can operate independent of the heating control. Therefore, **Never** incorporate automatic controls that electrically isolate the appliance. This is also important when the appliance is installed into an air handling appliance.

NOTE: EURO.T AIR HEATERS ARE SUPPLIED WITH EXTERNAL CONTROL CIRCUITS BRIDGED. THE AIR HEATER/S WILL OPERATE CONTINUOUSLY UNLESS THESE ARE REMOVED AND TIME AND TEMPERATURE CONTROLS SUBSTITUTED FOR THEM

SECTION 7. COMMISSIONING, LIGHTING AND OPERATION

SPECIAL NOTE

The following instructions have been written assuming that the Euro-T...D air heater is installed as a heating module independent of being installed within an air handling appliance. When installed within an air handling appliance or as part of a multi-appliance/purpose system it will be necessary to read any supplementary instructions in conjunction with this document.

COMMISSIONING

7.1 Normally Reznor Euro-T air heaters do not require commissioning. Final testing after production ensures that: If installation has been carried out strictly in accordance with this document, the appliance is ready to be taken into service.

7.2 Checks to ensure;

- earth continuity
- resistance to earth
- phase supply to correct terminals
- current rating and fuse value
- correct supply gas pressure
- correct burner gas pressure
- satisfactory & smooth ignition
- Flue system is evacuating the products of combustion to outdoor atmosphere

Must be made.

7.3 LIGHTING

- Ensure that air discharge louvres if fitted are set to open.
- Turn on gas supply.
- Switch on electrical supply.
- Set time switch (if fitted) to an 'ON' cycle.
- Set room thermostat to 'ON' position.
- If reset button on heater and/or on remote control (if fitted) glows, press reset button.
- Heater should now light automatically within 2 minutes. after a further period the air circulation fan should run, (see also below: section 7.6.6).
- For a new installation or if the appliance has been turned off for an extended period then up to 3 attempts to light the air heater may be necessary. If the heater still does not light, consult the fault finding guide section 9.

7.4 OPERATION

Refer to figure 13.

7.4.1 At the dictates of the external controls, an electrical circuit is made and the combustion air fan ("venter") runs.

7.4.2 Provided adequate air flow is proved, the fan will continue to run approximately 30 sec. (pre-purge period).

7.4.3 Euro-T air heaters employ the direct burner ignition principle. A hot surface igniter will glow for ± 15 seconds, after which time the gas valve(s) will open and the burner will be lit.

7.4.4 If the burner has not lit within 5 seconds, the electronic flame relay will switch off and lockout will occur. This will cause the signal lamp to glow within the reset push-button on the appliance and/or on a remote control if fitted). After 10 seconds the reset button on the appliance or the remote control can be activated in order to reset and restart the appliance.

7.4.5 Flame failure protection is by the ionisation principle i.e. the ability of a suitable flame to pass an electrical current between the igniter and the earthed burner assembly. To check the flame current is adequate, remove jumper between terminal 17 and 18 on the automatic burner control, connect a DC micro ammeter between the terminals. Ionisation current should be $\geq 2\mu\text{A}$.

Note: The terminals carry mains voltage when energised.

7.4.6 Simultaneously to the ignition circuit and gas valve circuit being energised, electrical power is supplied to an anticipator within the air circulation thermal fan control. The air circulation fan will start after about 2 minutes and warm air at a temperature of approximately 40°C is now discharged from the appliance.

7.4.7 In the event of the combustion air volume falling below a safe level, the burner will be extinguished a re-start cycle will commence after adequate combustion air volume has been restored.

7.4.8 If the burner flame is extinguished for any reason during a run cycle, an automatic attempt for re-ignition will take place, if the burner does not relight then safety shut down and lockout will occur. Manual intervention to reset is necessary to put the air heater back into service.

7.4.9 In the event of overheating for any reason, thermally activated fail safe overheat controls operate to switch off the burner.

The first control (LC1) switches off the burner and upon its cooling, automatically resets and the lighting sequence starts automatically. The second control (LC3) which operates at a higher temperature setting, will switch off the burner and itself set to a lockout condition which also requires manual intervention to reset to restore the heater to operational condition. A cooling time of ± 1 minute is necessary before thermal re-setting can be carried out

7.4.10 When the set temperature or the heating time period has been reached, electrical power to the burner relay will be switched off and the burner will extinguish. The air fan will continue to run until the heat exchanger has been cooled down to a safe level.

7.4.11 To turn off the air heater for a short period,
a. turn room thermostat to lowest setting.

To relight reset thermostat.

For prolonged period;

- a. turn room thermostat to low setting,
- b. turn gas supply to the appliance off.
- c. switch off electricity supply to the air heater **after air circulation fan has stopped.**

To relight follow lighting instructions.

7.4.12 The gas service tap must only be operated in emergencies, for servicing or prolonged periods of shutdown of the air heater.

SECTION 8. MAINTENANCE

8.1 General

Before commencing servicing, turn off the main gas supply and switch off the main electricity supply **after the air circulation fan has stopped.**

8.2 It is recommended that maintenance is carried out at least once a year. More frequent servicing may be required dependent upon the environmental circumstances where the air heater is installed. Regular inspection is necessary, especially in dirty areas, to assess the servicing frequency.

8.3 Check condition and security of flue and combustion air system.

8.4 Check for security and worthiness of the suspension or mounting system.

8.5 **To gain access to the controls and flue gas fan assembly.**

8.5.1 For appliances fitted with vertical flue systems, refer to figure 8. Follow the four step procedure:

- 1. Unlatch cam fastener ¼ turn counter clockwise on controls compartment access panel.
- 2. Remove access panel.
- 3. Unscrew retaining screw at top of upper cover panel.
- 4. Upper panel can now be removed by pushing upwards 2 cm to disengage panel retaining lugs and then lifted away.
- 5. The flue installation should include a service access section adjacent to the connection socket allowing access to the top of the flue fan. In the event that the fan housing assembly requires removal i.e. for replacement, then it is necessary to remove that section to access the 4 securing screws that fasten the fan housing through the top of the appliance.
All controls, electrical and flue gas components are now accessible.

8.5.2 For appliances fitted with horizontal flue systems: follow steps 1 & 2 above and then;

- 1. Disconnect flue and combustion air inlet pipes at the section provided. Ensure that the pipes will remain supported when disconnection has

been made.

- 2. Remove 4 sheet metal screws securing the venter fan to the upper cover panel.
- 3. Follow steps 3 & 4 8.5.1 above.

8.5.3 To replace reverse order above as appropriate.

8.6 If it is necessary to remove the cabinet top panel to gain access to the flue products collector box or the top of the heat exchanger, it is necessary to:

- 1. Isolate and disconnect the electrical and external controls wiring that passes through the panel.
- 2. Isolate and disconnect the gas service to the air heater.
- 3. Remove all of the sheet metal screws that secure the top panel to the appliance and remove panel as required.

8.7 Remove all dust and dirt from the combustion air fan (venter) see fig. 10 If dismantling venter observe critical dimensions before reassembly.

8.8 Check that air circulating fan guard is undamaged and secure.

8.9 Check security of the fan blade and fan motor. **Note:** The fan motor is lubricated for life and does not require lubrication.

8.10 Inspect hot surface igniter fig.9 replace if in doubt about its condition. **Note: The Igniter device is fragile, therefore, handle carefully**

8.11 Inspect and clean the burner assembly, refer to fig.11

8.12 Inspect heat exchanger and clean as necessary. This can only be done after removing the burner assembly.

8.13 After removal of burner assembly, each element of the heat exchanger can be cleaned by use of a soft brush and compressed air. Clean both inside and the outside surfaces.

8.14 Clean burners and gas jets with soft brush and compressed air. To prevent damage, do not use hard objects for cleaning the gas injectors

8.15 If anchor lines of service panels are removed during servicing, they must be refitted upon completion of the service.

8.16 Upon completion of any service work it is necessary to re-commission the appliance in accordance with the step procedure described in section 7.7.2 of this document.

Fig. 9 SERVICE ACCESS KEYS

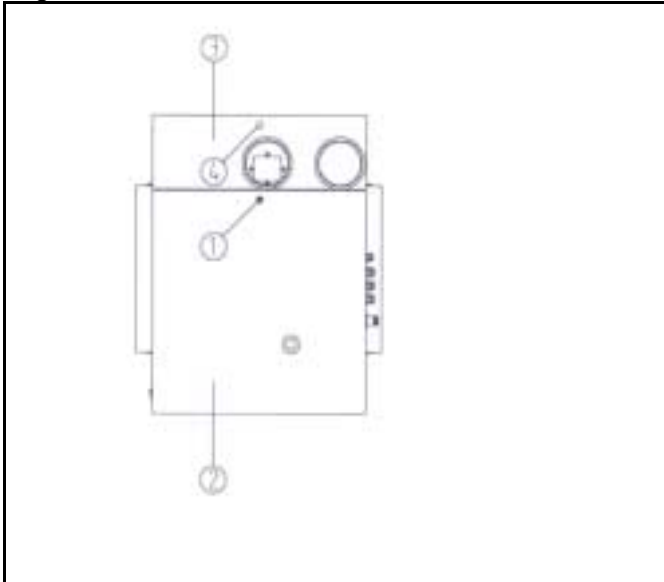

Fig.10 IGNITER ASSEMBLY

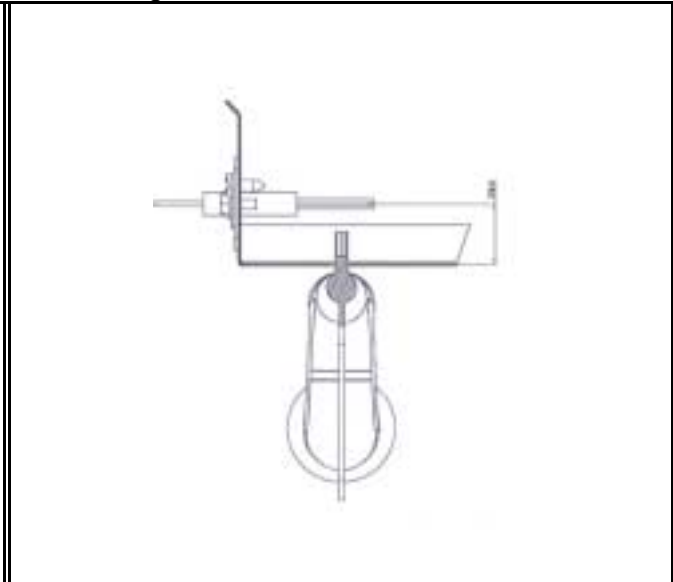
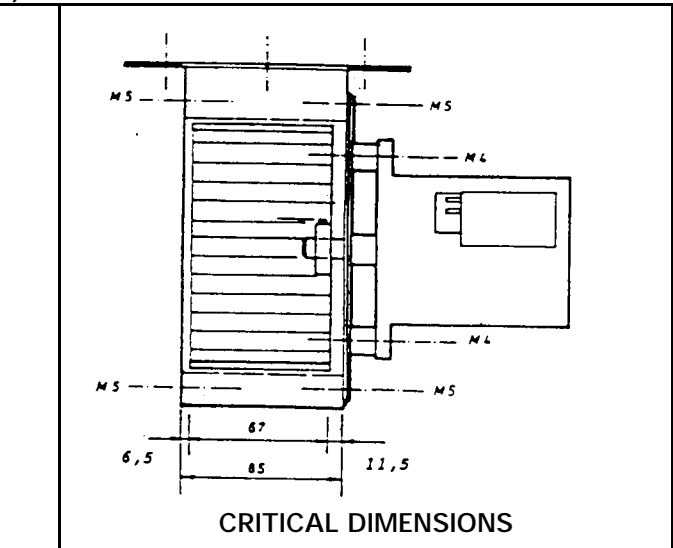
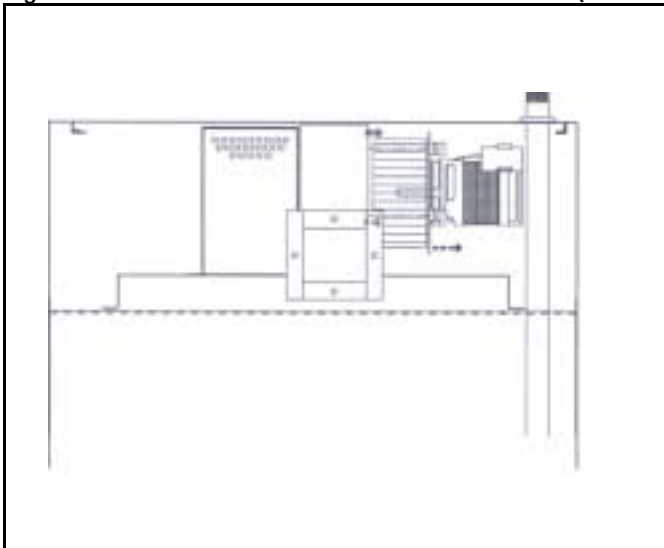

Fig. 11 REMOVAL OF COMBUSTION AIR FAN (VENTER) MOTOR FAN IMPELLER ASSEMBLY



8.15 TO REMOVE COMBUSTION AIR FAN:

1. Disconnect electrical connections to fan motor.
2. Remove motor and venter wheel (3 screws).
3. Withdraw motor/impeller assembly sideways.
4. Clean venter housing.
5. Check, clean or replace motor and/or venter wheel.
6. Replace in reversed order after checking critical dimensions (fig. 11)

Fig. 12 REMOVAL OF BURNER ASSEMBLY

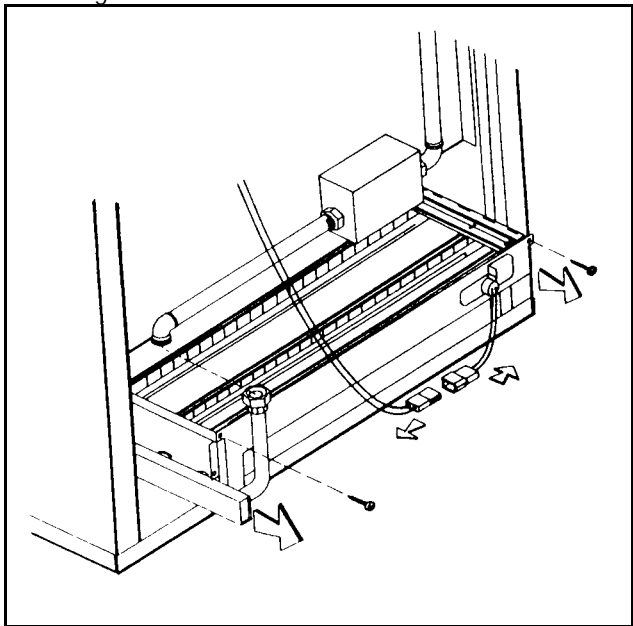

TO REMOVE BURNER ASSEMBLY:

1. Turn off the main gas supply.
2. Switch off the main electricity supply **after air circulation fan has stopped.**
3. Open service panel fig.8.
4. Disconnect wires of igniter.
5. Disconnect union fittings between gas valve(s) and burner.
6. Unscrew fixing screws of burner and pull forward burner assembly on it's slide rails.
7. Replace in reversed order

Figure. 13

COMPONENT PARTS LAY OUT

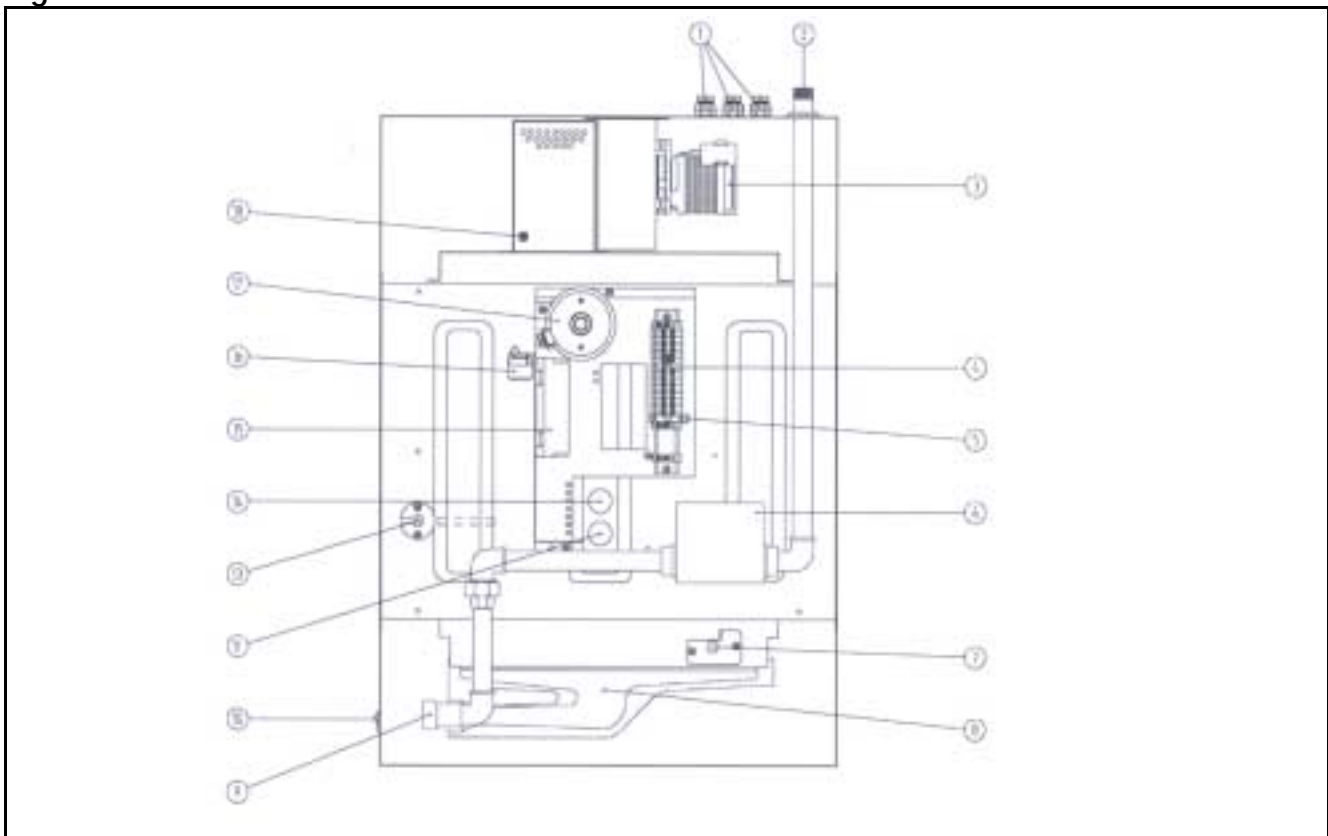

Legend:

- | | |
|---|--|
| <ol style="list-style-type: none"> 1. Cable entry all electrical connections 2. Gas connection 3/4" (not supply line size) 3. Combustion air fan with motor 4. Terminals for all electrical connections 5. Fuse 6. Double gas valve with pressure regulator 7. Hot surface igniter 8. Burner tray with burner ribbons 9. Manifold with injectors and pressure nipple | <ol style="list-style-type: none"> 10. Reset button with indicator for burner lock-out 11. Fan thermostat (FCR) 12. Not used for UK! 13. Bulb of thermal overhear and seal/grip (LC3) 14. Thermal overhear control (LC1) 15. Burner relay 16. Thermal overhear control (LC3) 17. Differential switch 18. Differential pressure reference point nipple |
|---|--|

THE APPLIANCE WILL ONLY OPERATE WITH ALL PANELS CORRECTLY FITTED !!

SECTION 9. FAULT FINDING

THE APPLIANCE WILL ONLY OPERATE WITH ALL PANELS CORRECTLY FITTED !!

9.1 Burner does not ignite

- Thermostat set too low or time switch not correctly set; no power to terminals 2 and 5.
- Fuse F3 has blown; no power to terminal 2 and LC3.
- Reference tube to differential air pressure switch S3 is not airtight or blocked.
- Faulty differential air pressure switch S3; no power to terminals 2 and 13.
- Insufficient differential pressure in flue pipe system; Flue blocked or too long.
- Burner relay in lockout (point 2 below) or faulty.
- Faulty combustion air fan M3 (venter).
- Faulty limit control LC1; no power to terminal 2 and LC1.
- Overheat control LC3 in lockout; no power to terminal 2 and LC3; Reset manually.

9.2 Flame relay in lockout

- Air in gas service; purge.
- Low gas pressure.
- Faulty hot surface igniter.
- Faulty differential air pressure switch.
- Gas valve does not open; no power to terminals 2 and 7.
- Insufficient ionisation flame current; ionisation current $\geq 2\mu\text{A}$.
- Incorrect wiring of mains input line, neutral, earth.

9.3. Combustion air fan (venter) does not start

- Faulty motor or capacitor.
- Faulty burner relay.
- Differential air pressure switch S3 still in normal run position no change-over.
- Faulty fuse F3.

9.4 Differential air pressure switch switches burner off

- Switch-point should be; ON 1,02 mbar, OFF 0,94 mbar, except type..25/26: ON 0,76 mbar, OFF 0,68 mbar.
- No differential pressure in flue gas system; check flue and air inlet.
- Faulty combustion air fan or capacitor.

9.5 Appliance does not provide sufficient warm air

- Check gas inlet pressure.
- Check burner pressure.
- Gas filter (if fitted) dirty or blocked.
- Limit control (LC1) switches burner off (see 9.6).
- Differential pressure switches relay off (see 9.4).

9.6 Limit control LC1 switches burner off

- Switch temperature 51,5°C, ..55/56....95/96 top connection: 63°C.
- Insufficient air flow.
- Vertical and horizontal louvres set in closed position.
- Burner overload, check burner and inlet gas pressure.
- Fan control switch faulty
- Check fan rotational direction.
- Air temperature at fan inlet too high; T max. 30°C (see 9.6).
- Thermal contact in fan motor switches off intermittently.

9.7 Limit control LC3 switches

- Switch temperature 96°C (+ 0/-5).
- Check location and security of capillary and probe.
- Air discharge temperature too high (see 9.6).
- Faulty limit control LC1.
- Air fan stops immediately after burner is switched off; incorrect control/s wiring.
- Faulty fan control (FC).

9.8 Air fan does not start

- No power to terminals 2 and 11.
- Faulty fan control (FC).
- Faulty motor or capacitor.
- Thermal over-load in motor switching.

9.9 Fan starts and stops intermittently while burner is on.

- Faulty heat anticipator (FCR) in fan switch.
- Thermal over-load in motor switching.
- Inlet ambient air temperature too low; T min. $< 5^{\circ}\text{C}$.; will correct as space temperature rises.
- Faulty wiring connection; loose terminals!

SECTION 10. SPARE PARTS LIST

10.1 GAS SECTION

DESCRIPTION	PART NUMBER	MFGS.REF.	APPLICATION
Gas valve single stage burners	03 25250	SIT 830 Tandem	2..25/26 - 2..35/36
Gas valve single stage burners	03 25136	H'well VR4601AB	2..45/46 - 2..95/96
Gas valve two stage burners	03 35136	H'well VR4601BP	Two stage options

10.2 ELECTRICAL SECTION

DESCRIPTION	PART NUMBER	MFGS.REF.	APPLICATION
Thermal fan control	03 25166	TOD29T12 (250V)	All
Thermal over-heat control (limit) LC1	03 24970	TOD60T11	All
Thermal over-heat control LC3	03 24959	limit 96° C	All
Combustion fan motor + wheel assy.	36 79090	Drouard-tec CP 78	All
Combustion circuit pressure switch	30 30607 68	Honeywell C6065 FH1144	Models < 2.25/26
Combustion circuit pressure switch	30 60607 94	Honeywell C6065 FH1194	Models except 2.25/26
Automatic burner control	03 25317	Honeywell S4570LS	All
Hot surface ignition assembly	05 25217	Norton 240V	All
Two pole relay K1.2	30 61738 240V	Omron G7L2A	All two stage burners
Wiring harness for burner control	06 41531 HGC	----	All
Wiring connector for igniter device	06 41531 HGC	----	All
Wiring harness for two stage burners	06 41621	----	All
Wiring terminals	06 41635	Entrelec	All

10.3 MISCELLANEOUS

DESCRIPTION	PART NUMBER	MFGS. REF.	APPLICATION
Combustion air fan impeller	02 25730	Punker	All
Suspension sockets 1" BSP (R1)	35 20003 2000	Al	Options
Sampling pressure test point	07 25811 02	M8	All
Silicon tubing	06 20224 cm	ø 5-8 mm x 1.0 m	All
Combustion fan assembly gasket	11 44696	---	All
Capillary seal plate assembly	08 07727	---	All

SECTION 11. GAS CONVERSION

11.1 This air heater is designed to operate on natural, propane or butane gas and will be supplied as ordered for the gas type specified. In the event it is required to convert to a different gas type to that which has been supplied, conversion of the gas burner must be carried out.

11.2 A Reznor approved conversion kit to suit the appropriate gas type must be used.

11.3 In addition to changing the burner injectors, and adjusting the gas pressure, sealing a governor or fitting a blanking plate it is necessary to fix over stickers as supplied with the conversion kit of parts.

11.4 After conversion re-commission appliance according to section 7 of this document.

Figure. 14 BURNER AIR SHUTTER & SETTING DIMENSION for all GASES UK & IE

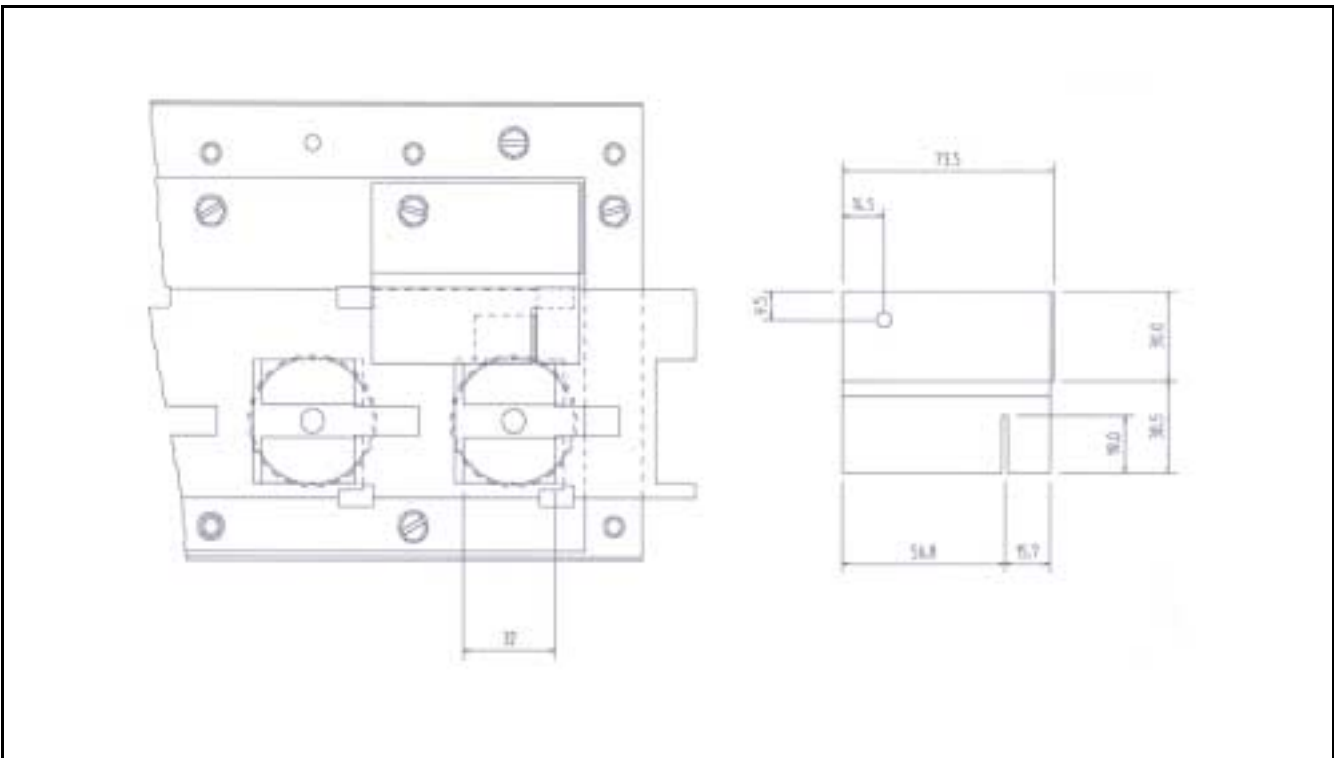

SECTION 12. HEALTH & SAFETY STATEMENT

Health and Safety Information for the Installer and Commissioning/Service Engineer

12.1 General

Under the Consumer Protection Act 1987 and Section 6 of the Health and Safety at Work Act 1974 we hereby provide the following information on substances hazardous to health.

Product range reference Euro-T.. Series air heaters.

First Aid: Medical attention must be sought following eye contact or prolonged reddening of the skin.

12.2 Cautionary note

During first firing some smoking may occur, this is due to the burning off of protective/lubricating oils used during appliance production. Most of this will have been removed during the production testing process. It is a wise precaution to ensure that adequate ventilation is provided during the initial firing and throughout the commissioning period, this is particularly important if the discharge air is to blow into a confined space. This smoking does not constitute a poison hazard.

12.6 Thermostat.(Thermal overheat (limit) control LC3)

Material: Illuminating Kerosene.

Description: Sealed phial contains a small quantity in liquid form.

Recognition: Colourless liquid, paraffin oil/petroleum hydrocarbon odour.

Characteristics: Non-corrosive, flammable with no poisonous reference-CH poison Class 3

Precautions: Avoid handling. This product can irritate and defat the skin. Prolonged contact may cause dermatitis. Avoid breathing vapour. Avoid eye contact. Do not ingest.

12.3 Declaration

Reznor products contain no asbestos; copper is not employed in gas carrying components; solder which has a melting point below 450°C is not used; paints for corrosion protection and decoration are heat cured and contain no lead.

First Aid: Skin. Wash thoroughly with soap and water.

Eyes. Rinse immediately with copious amounts of clean water.

Ingestion: Seek medical advice.

12.3.1 The above appliances meet the Electrical Safety requirements of EN60 335 Pt 1 1988.

NOTE: If skin irritation persists seek medical advice.

12.4 Miscellaneous

Small quantities of adhesives and sealants used in the product are dried and cured and present no known hazard.

12.7 Electrolytic Capacitor

Two types are used by random selection:

Recognition: 1. Plastic enclosure 2. Aluminium enclosure

12.5 Insulation and Seals.

Material: Alumino - silicon fibre

Material: Contained liquid electrolyte

Description: Tapes

Known hazards: Electric shock possible if charged.

Known hazards: Some people can suffer reddening and itching of the skin. Fibre entry into the eyes will cause foreign body irritation.

Inhalation will cause irritation to the respiratory tract.

Precautions: Discharge to ground/earth. Do not incinerate.

First Aid: Treat for electric shock if affected.

Precautions: Wear protective gloves when handling.

People with a history of skin complaints may be susceptible to irritation.

Dust levels are only likely when the material is abraded.

In general normal handling and use for this purpose will not present discomfort. Follow good hygiene practices, wash hands before consuming food or using the toilet.

END OF HEALTH AND SAFETY STATEMENT

Reznor 08/01

SECTION 13. USER INSTRUCTIONS Euro-T.. AIR HEATERS

SPECIAL NOTE

The following instructions have been written assuming that the Euro-T...D air heater is installed as a heating module independent of being installed within an air handling appliance. When installed within an air handling appliance or as part of a multi-appliance/purpose system it will be necessary to read any supplementary instructions in conjunction with this document.

OPERATING

How the air heater works:

Gas is burned by an atmospheric burner which fires into a heat exchanger. The gas burner is controlled by a double gas valve via an electronic burner control, which is actuated automatically via external controls i.e. a room thermostat and/or a time switch. The burner is ignited by a hot surface igniter. When the burner fires and warms the heat exchanger, the heat is sensed by a thermally actuated fan control which switches on the fan when the air temperature has reached its preset operating level.

At the end of a heating cycle the burner is switched off, the air circulation fan will continue to run until the air heater has cooled to a safe condition. Thereafter the fan will remain off until the next cycle is initiated.

Safety:

1. Flame failure is detected by the hot surface igniter which is also the sensor and will immediately result in gas valve shut down.
2. Safety against overheating is assured by two overheat controls. The first is an automatic recycle control which protects against low air flow i.e. clogged air ways, fan failure etc. The second, which is set to a higher level than the first one, is a control which locks out and switches off the burner in the event of gross overheating for any reason. Manual intervention is necessary to reset this control device. Resetting of the automatic burner control may also be required.
3. The location of the air heater should be maintained at normal atmospheric pressure. Changes to the building after air heater installation, should have regard to the heating installation, i.e. structural changes causing excessive draught from doors, windows etc. Other air handlers and installation of air extraction equipment which may cause a negative pressure environment, can seriously affect the operation of this type of air heater, especially if combustion air supply is not ducted.

To light the heater:

1. Turn on the gas supply to the air heater.
2. Switch on the electricity supply to the air heater.
3. Ensure time switch (if fitted) is set to a 'ON' cycle.
4. Adjust control/room thermostat to desired temperature.
5. Air heater will light automatically when the room thermostat calls for heat.

6. If the appliance does not light:
 - a) check that the burner control does not require resetting. An indicator light glows at the front panel of the appliance and on a remote control (if fitted). Reset by pushing light/button on appliance or the remote control.
 - b) check if thermal overheat control requires resetting (see fig. 12 page 15 key 16).
7. If the thermal overheat control requires resetting and doing so restarts the air heater, wait until the appliance warms to thermal equilibrium, to ensure the overheat control does not lock out again. **If it does and the temperature near the heater is less than 30°C, then switch off the appliance and call for service.** If the temperature is over 30°C, take appropriate action to reduce the ambient temperature near the air heater.

Air circulation:

1. The space heating process is for air to be circulated through the appliance whereby it gains heat from a heat exchanger. The air is directly discharged into the space to be heated. The air is eventually re-circulated. Therefore it is very important that an unobstructed path for the circulation of the air will be maintained. This is particularly important if the air heater has been installed to blow through the wall between two rooms.
2. Sometimes the air circulation fan of the appliance is connected to a remote over-ride switch. This enables cool air to be used for circulation purposes when the air heater is not used for heating purposes e.g. in summer.
To use this feature:
 - a) switch ON electricity
 - b) switch ON manual override switch, this may be fitted as a feature on a remote composite control.

Maintenance:

1. Maintenance and service must only be carried out by appropriately qualified persons e.g. "Corgi" registered undertakings.
2. It is in your interest to ensure service and maintenance is carried out at regular intervals. Periods between service are dependent upon the local environment where the heater is installed. All gas appliances should be serviced at least once a year.
3. In case of any damage to the appliance, it must be shut down completely and checked by an appropriately qualified person.
4. In the event of difficulties in resolving any of these matters, please do not hesitate to contact Reznor or their official distributor.

Reznor® EURO-T 2000 D

ONE OF A GENERATION OF CE MARKED GAS FIRED ENERGY
EFFICIENT AIR HEATERS

BEST USED WITH Reznor OPTIONAL ELECTRONIC CONTROL PANELS
SAVE ENERGY AND OPTIMISE THERMAL COMFORT

Reznor® Europe N.V.
J&M Sabbestraat 130
B8930 Menen
Belgium
Tel:+32(0)56 52 95 11
Fax:+32(0)56 52 95 33
e-mail:reznor_europe@tnb.com

Reznor UK Limited
Park Farm road
Folkestone
Kent
CT19 5DR
Tel: + 44 (0)303 259141
Fax: + 44 (0)303 850002
e-mail: sales@reznor.co.uk

Thomas&Betts
