

GAS FIRED AIR HEATERS TYPE EURO-T 2000 S

Axial Fanned, Forced Convection Appliances with
Automatic Ignition and Fanned Flues for use as:
Type B22 - C12 - C32

INSTALLATION COMMISSIONING SERVICING & USER INSTRUCTIONS

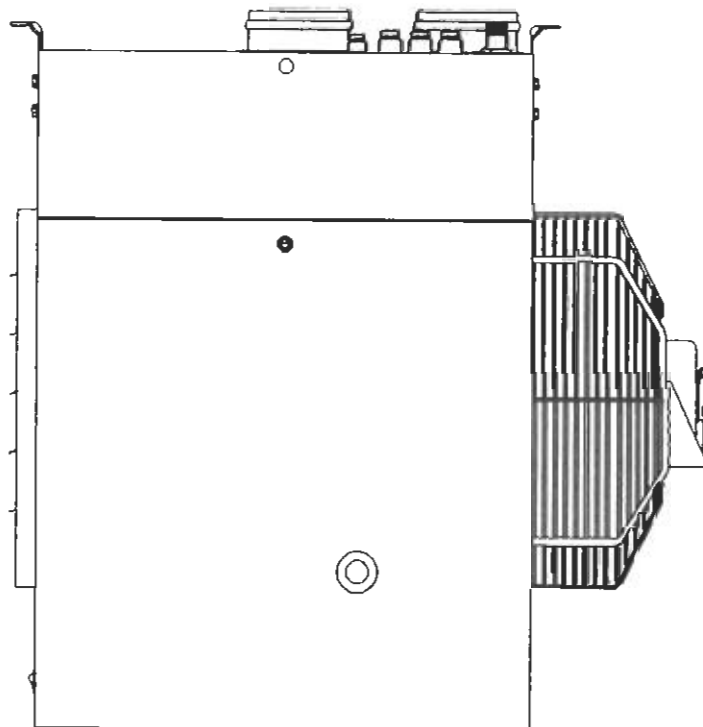

These appliances meet the following EC Directives:

Dir. CE 90/396/EEC:	GAD
Dir. CE 89/336/EEC:	EMC
Dir. CE 89/392/EEC:	MD
Dir. CE 73/23/EEC:	LVD

PLEASE READ THIS DOCUMENT CAREFULLY BEFORE COMMENCING INSTALLATION AND LEAVE IT WITH THE USER OR ATTACHED TO THE APPLIANCE OR GAS SERVICE AFTER INSTALLATION.

INDEX

Page

1. General	2
2. Technical data	3
3. Installing	5
4. Combustion, Air supply and flue system	6
5. Gas connection	8
6. Electrical connection	8
7. Commissioning, lighting and operation	8
8. Maintenance	10
9. Fault finding	13
10. Spare parts list	14
11. Gas conversion	15
12. Health and Safety Statement	16
13. User instructions	17

If optional equipment was ordered and supplied with this air heater, please refer to additional instructions for option(s).

SECTION 1. GENERAL

- 1.1 Before installation, check that the appliance as described on the packaging label is in accordance with the correct type and model as specified on the data plate and complies with your customer order.
- 1.2 After unpacking the appliance, leave it fastened to the wooden pallet until it has been suspended or until just before base mounting. This affords protection to the painted underside which is normally exposed to view after installation.
- 1.3 Please read this document before commencing installation.
- 1.4 These instructions are only valid for the country of use indicated on the appliance i.e.: GB - IE. If these symbols are not shown, it is necessary to obtain appropriate technical instructions which will provide information concerning the necessary modification of the appliance for the conditions of use in the country concerned. Such instructions may be obtained upon request from your supplier.
- 1.5 Check that the local distribution conditions of electricity supply, type of gas and pressure, and adjustment of the appliance are compatible.
- 1.6 When installed in Great Britain the total installation must comply with the requirements and recommendations of British Standard BS 6230 1991. "Installation of Gas Fired Forced Convection Air Heaters for Commercial and Industrial Space Heating".
The Installation must also be in accordance with the relevant requirements of "The Gas Safety (Installation and Use regulations) and (Amendment Regulations 1990)" and The "Building" and "Electrical Regulations" (in GB the IEE Regulations). The requirements of the "Local Building Standards Office", the premises "Insurance" undertaking and the "Fire Office" must also be observed.
- 1.7 Unauthorized modification of this appliance or departure from use in the manner for which it was intended by the manufacturer or installation in a manner contrary to these instructions, may constitute a hazard and jeopardize all warranties. Deviations should only be carried out after formal consent has been obtained from the manufacturer.
- 1.8 Ensure the environment in which the air heater will be installed will not create a hazard i.e. where excessive (volatile) dust, flammable or corrosive substances and/or vapours and combustible materials may be present.
- 1.9 This appliance has been tested, and set according to the data plate before leaving the factory.

SECTION 2. TECHNICAL DATA

Table 1. Appliance Data Standard Efficiency

Type EURO-T 2025S	..30S	..35S	..45S	..55S	..75S	..95S
Gas category 'Cat.'			H ₂ H ₃ .						
Air supply and flue type			B22 - C12 - C32						
Heat input (Hs) 'Qn'	kW		28,8	35,2	42,7	49,9	63,2	86,5	115,4
Heat input (Hi) 'Qn'	kW		26,0	31,7	38,5	45,0	57,0	78,0	104,0
High heat output	kW		22,8	27,8	33,7	39,4	49,9	68,3	91,0
Number of jets			4	5	7		9	12	16
Jet size	natural gas	∅ mm	2.4		2.2	2.4			
	propane/butane	∅ mm	1.35		1.25	1.35			
Gas supply pressure 'P' ¹	natural gas	mbar	(GB) = 17.5 (IE) = 20.0						
	propane	mbar	37.0						
	butane	mbar	28.0						
Burner pressure ²	natural gas	mbar	8.50						
Gas consumption	natural gas ³	m ³ /h	2.75	3.36	4.04	4.76	6.02	8.30	11.00
	propane	kg/h	2.06	2.52	3.05	3.56	4.51	6.18	8.25
	butane	kg/h	2.10	2.60	3.12	3.64	4.61	6.31	8.42
Gas service connection (not supply line size)			Rc ¾						
Temperature rise ΔT (± 1)	K		39	34	27	32	35	36	34
Air volume ⁴	m ³ /h		1700	2400	3700		4200	5600	7900
Throw (terminal V ₀ = 0,5 m/s)	<m		17	20	28		26	32	38
Nominal fan speed	rpm		1500	950					
Sound power level L _w	dB(A)		68	67	70			71	74
Sound pressure level L _p ⁵	dB(A)		53	52	55			56	60
Electrical supply			230/240V 1 N - 50Hz						
Protection grade			IP20						
Fan motor rating	W		75		120			2 x 120	
*Total electric rating ⁶	W		250	270	300			540	600
Appliance weight net	kg		86	92	108		130	150	195
Appliance weight gross (shipping)	± kg		96	103	122		143	170	225

- 1 Maximum gas pressure at inlet to appliance = 50,0 mbar
- 2 All casing panels fitted, service door open
- 3 Natural gas G20, calorific heating value 10,5 kWh/m³ on Hs @ 15°C & 1013 mbar
Propane G31, calorific heating value 14,0 kWh/kg. Butane G30, calorific heating value 13,7 kWh/kg
- 4 Isothermic condition (20 °C)
- 5 Q = 2, A = 160 2m², louvres no deflection, isothermic condition,
- 6 Total electrical rating during the start-up period ± 30 seconds is increased by 130 W and is not included on the appliance data plate or in the above table

Table 2. Technical data higher efficiency models

Euro-T...	Model	2026S	2031S	2036S	2046S	2056S	2076S	2096S
Heat output normal rate	kW	23.7	28.8	35.0	41.0	51.9	71.0	94.6
Temperature rise $\Delta T (\pm 1)$	K	41	35	28	33	36	37	35

All other data is the same as for the standard efficiency version

Figure 1. DIMENSIONS

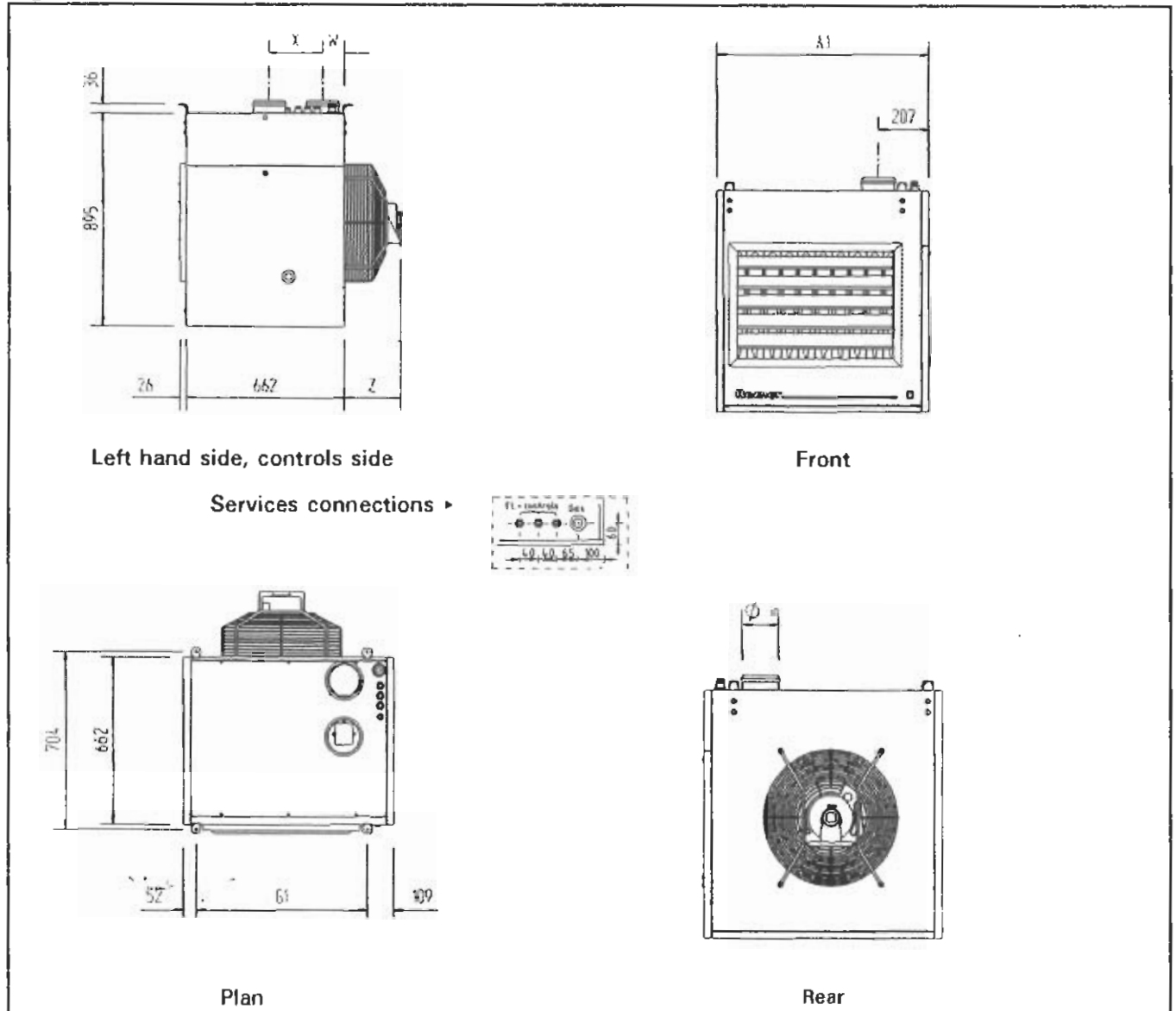

Table 3 Dimensions reference fig. 1

Model	2025	2030	2035	2045	2055	2075	2095
Dimension	2026	2031	2036	2046	2056	2076	2096
A1 Width overall	520	590	730		870	1080	1360
∅ Flue & combustion air intake socket internal ∅	102			132			
X Flue & combustion air intake socket centres	140			225			
G1 Width of suspension points	359	429	569		709	919	1199
Z Fan assembly overall depth	243	274	303		343	274	343

SECTION 3 INSTALLING

- 3.1 Figure 2 shows the clearances necessary to ensure safety for combustibles and service access.
- 3.2 Ensure that the structural elements which will be used to suspend or support the appliance, are adequate to carry the weight of the appliance and its ancillary components i.e. flue system.
- 3.3 The location where the air heater is to be installed, must provide sufficient space around the heater for servicing and clearances for safety.
- 3.4 Ensure that the air heater is installed in a level plain.
- 3.5 Base mounting is optional; see fig. 2. The air heater must be fastened securely to any base mounting arrangement.
- 3.6 4 suspension brackets with holes \approx 10.5 mm are provided on top of the appliance. Use \approx 10 mm rods for suspending the heater. Specially designed wall brackets are available from your Reznor dealer.
- 3.7 After suspension, the air heater should be rigid so as to avoid placing a strain on the flue system, gas services and electrical wiring. Optional 1" BSP threaded sockets are available for alternative suspension arrangements.

SECTION 4. COMBUSTION AIR SUPPLY AND FLUE SYSTEM

- 4.1 Flue systems must comply with national and local regulations.
- 4.2 The products of combustion must be flued to outdoor atmosphere. Common flues for more than one appliance must **NOT** be used.
- 4.3 Combustion air should be taken from out-door atmosphere, this improves the operational efficiency of the heating system.
- 4.4 Flues and combustion air ducts where connected to the air heater must incorporate a disconnect section adjacent to the appliance to facilitate removal of the venter assembly for servicing. The flue system must therefore, be supported independently.
- 4.5 Dimensions and allowances in suggested flueing and combustion air intake arrangements are based upon the use of smooth wall aluminium flue and combustion air ducts and fittings.
- 4.6 **Type C Appliances**
 - 4.6.1 When using a concentric termination arrangement as figure 3, then only an approved system using Reznor specified components may be used. These items are manufactured from seamless aluminium with connection sockets fitted with silicone double edged seals, thus assuring, if the components are undamaged, leak free flue systems.
Important: This type of flue/Combustion air intake system is regarded as an integral part of the air heater therefore, departure from this method of flueing is in breach of the EC Gas Appliance Directive.
 - 4.6.2 Distance between the appliance and the concentric flue termination must not be greater than 9.0 m. When calculating the total length the following equivalent data must be taken into account:
1 elbow @ 45° = 1 m. 1 elbow @ 90° = 1,5 m.
- 4.7 **Type B Appliances**
 - 4.7.1 If the air heater is to be installed as a B type appliance i.e. air for combustion to be taken from within the space to be heated, then it must be ensured that an adequate air supply for combustion and ventilation is provided, in accordance with the regulations and rules in force.
 - 4.7.2 A horizontal distance between air heater and flue terminal and any combustion air intake duct, must not be in excess of 16 m.
Note: 2 Metres of vertical rise negates the resistance imposed by 1 meter of horizontal run. Runs exceeding 16 m may be subject to condensation forming within the flue.
Equivalent lengths of flue fittings:
Elbow @ 45° = 1 m. Elbow @ 90° = 1,5 m.
Flue terminal < 3.0 m.
 - 4.7.3 To ensure that the allowable resistance is not exceeded in the case of horizontal runs of flues, a positive rise from the air heater of 1° i.e. 17 mm per metre is recommended.
 - 4.7.4 If condensation is to be avoided, flues should be insulated if they are installed in cold areas.
 - 4.7.5 When mechanical ventilation is used, it shall be by mechanical inlet with either mechanical or natural extraction. Automatic means of control such as interlocks must be provided. The function of other ventilation systems in the heated zone must be taken into account. At no time should a negative pressure exist in the zone, this can lead to a hazardous situation, whereby the flue may act as a pressure relief.
 - 4.7.6 The terminal of a vertical flue must extend 1 m above a roof surface, flues must not terminate where combustion products might enter the building. Terminals must be fitted to flues and combustion air inlets. The combustion air inlet if not used must be protected with an access guard.

Figure 2

CLEARANCES SUSPENSION & MOUNTING

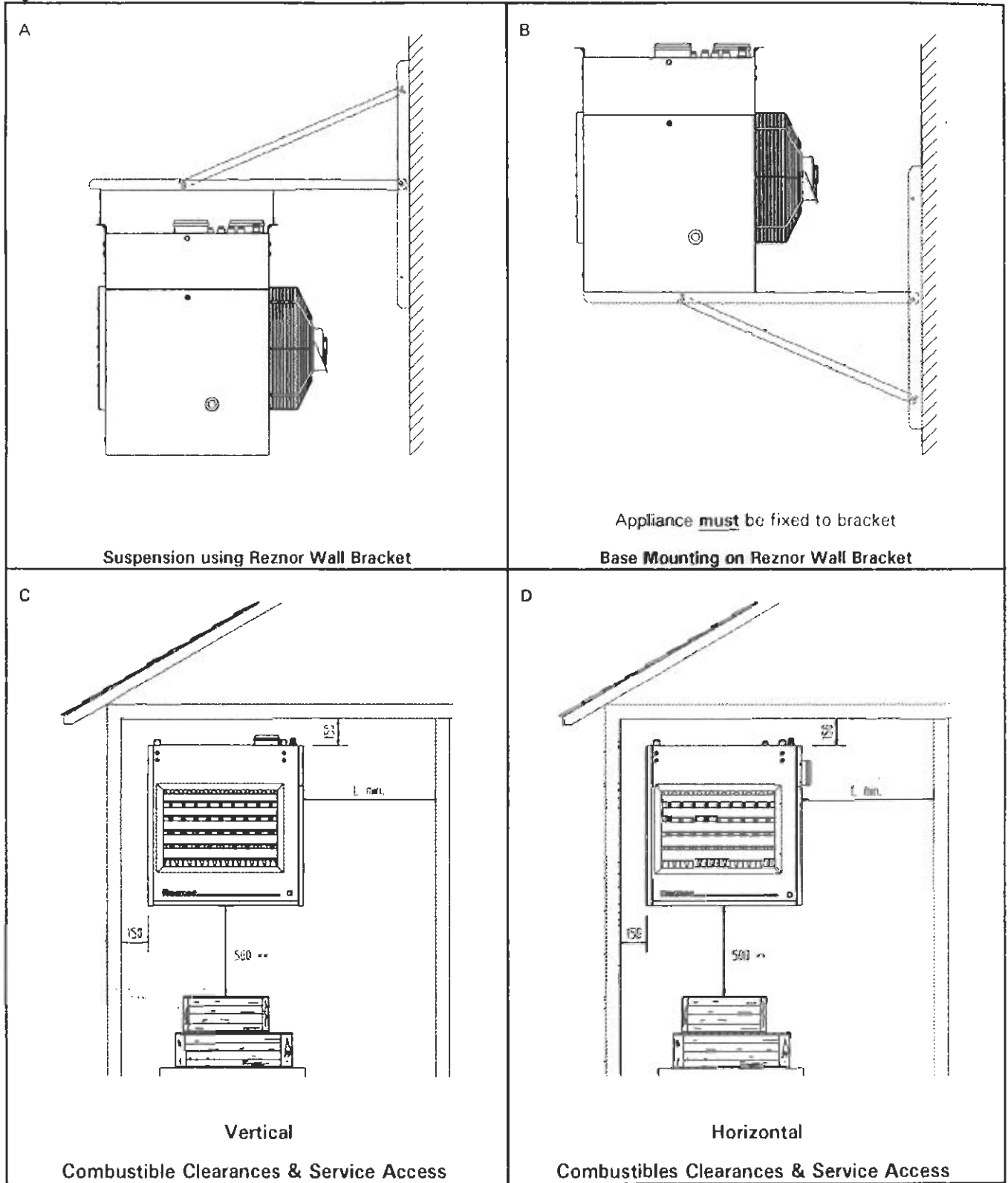

DIMENSIONS Re: FIGURE 2 C-D

Model	2025	2030	2035	2045	2055	2075	2095
Dims.	2026	2031	2036	2046	2056	2076	2096
L min.	550	620	750	750	900	1100	1400
Opposite L *	-	-	-	-	-	150 + 300	150 + 300

Note: * Models 2075/76 & 2095/96 require extra side clearance for access to LC 2 thermal overheat control.

WHEN INSTALLED AS A TYPE C APPLIANCE

Figure 3.

FLUE AND COMBUSTION AIR INTAKE ARRANGEMENTS

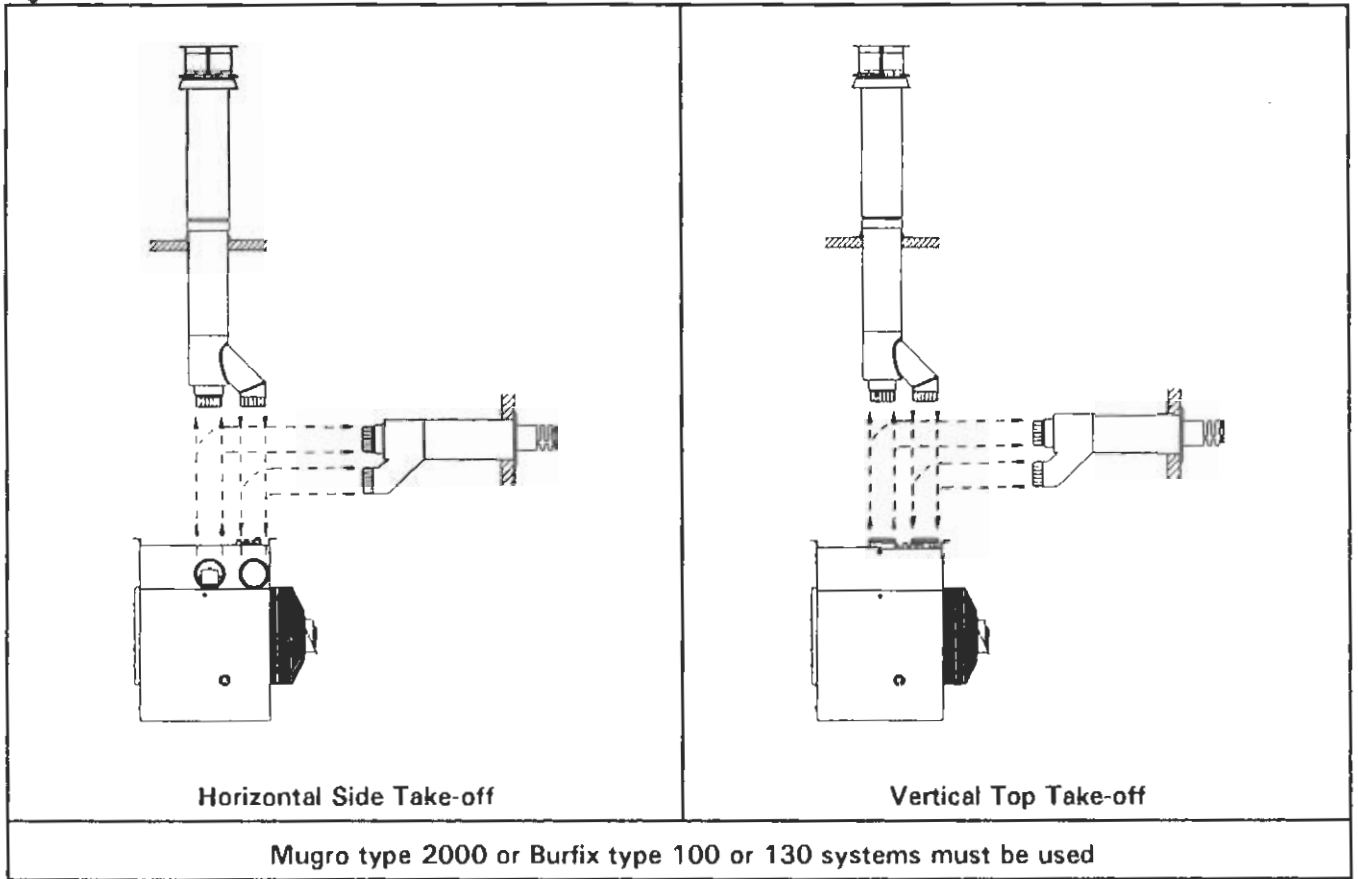

WHEN INSTALLED AS A TYPE B APPLIANCE

Figure 4.

FLUE AND COMBUSTION AIR INTAKE ARRANGEMENTS

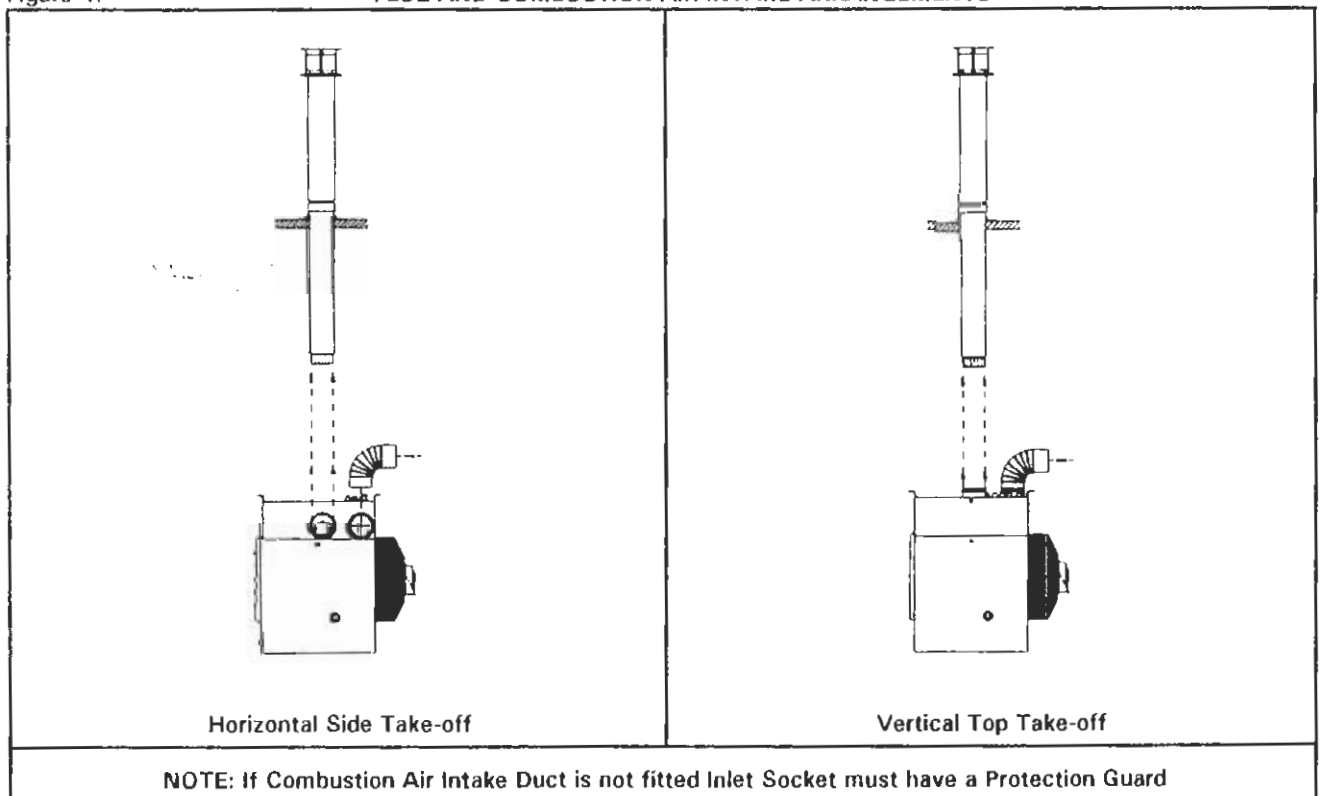

SECTION 5. GAS CONNECTION

- 5.1 Connection to a gas service may only be carried by suitably qualified persons. The gas installation must comply with the rules in force using materials appropriate for gas service installations.
- 5.2 Check that the gas category is in accordance with the data described on the air heater.
- 5.3 An adequate gas supply sized to provide the dynamic pressure for the volume required by the air heater(s) is essential to maintain the nominal heat input.
- 5.4 A 90° action gas service tap and, to facilitate servicing, a disconnect union fitting must be provided adjacent to the appliance, see fig. 5.
- 5.5 Ensure that a gas service includes a filter and has been tested and purged in accordance with prescribed practice prior to commissioning and taking the air heater into service.

Fig. 5 GAS CONNECTION DETAIL

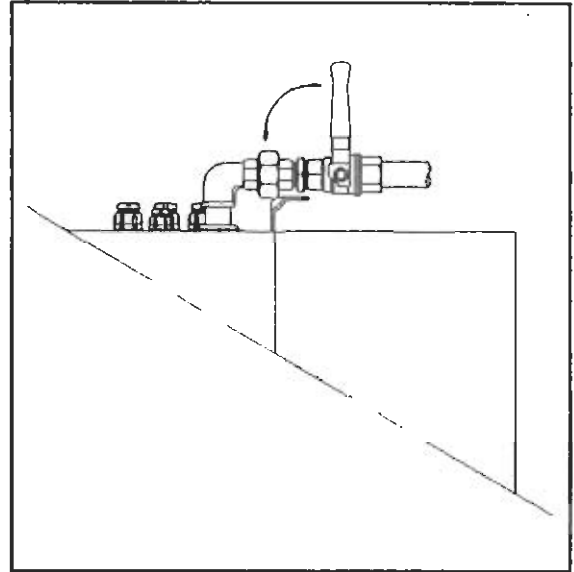

WARNING: NEVER use a FLAME to test for GAS Soundness !!!

SECTION 6. ELECTRICAL CONNECTION

- 6.1 The Electrical installation may only be carried out by suitably qualified persons observing the rules in force.
- 6.2 Check that the electrical specification is in accordance with the specified data on the air heater. A unique appliance wiring diagram is supplied as a separate document attached to this one, plus an additional copy attached to the air heater.
- 6.3 These appliances **must** be earthed.
- 6.4 A separate electrical isolator for each heater must be provided adjacent to the appliance. The isolator must have a contact separation of at least 3.0 mm on all poles.
- 6.5 Ancillary controls are required to provide timed heat cycles, room comfort temperature level, frost protection, override air circulation etc. These are not included with the appliance and should be ordered separately.
- 6.6 Ensure when planning the external appliance control circuitry, that power will be supplied at all times to the air heater, even when it is control switched in the 'heat-off' mode. This is necessary to ensure that the fan can operate independent of the heating control. Therefore, **Never** incorporate automatic controls that electrically isolate the appliance.

NOTE: EURO-T.. AIR HEATERS ARE SUPPLIED WITH EXTERNAL CONTROL CIRCUITS BRIDGED. THE AIR HEATERS WILL OPERATE CONTINUOUSLY UNLESS THESE ARE REMOVED AND TIME AND TEMPERATURE CONTROLS SUBSTITUTED FOR THEM

SECTION 7. COMMISSIONING, LIGHTING AND OPERATION

COMMISSIONING

7.1 Normally Reznor Euro-T air heaters do not require commissioning. Final testing after production ensures that: **If installation has been carried out strictly in accordance with this document**, the appliance is ready to be taken into service.

7.2 Checks to ensure;

- earth continuity
- resistance to earth
- phase supply to correct terminals
- current rating and fuse value
- correct supply gas pressure
- correct burner gas pressure
- satisfactory & smooth ignition
- Flue system is evacuating the products of combustion to outdoor atmosphere must be made.

7.3 LIGHTING

- Ensure that air discharge louvres are set to open.
- Turn on gas supply.
- Switch on electrical supply.
- Set time switch (if fitted) to an 'ON' cycle.
- Set room thermostat to 'ON' position.
- If reset button on heater and/or on remote control (if fitted) glows, press reset button.
- Heater should now light automatically within 2 minutes. After a further period the air circulation fan should run, (see also below: "operation" point 6).
- For a new installation or if the appliance has been turned off for an extended period then up to 3 attempts to light the air heater may be necessary. If the heater still does not light, consult the fault finding guide section 9.

7.4 **OPERATION** Refer to figure 10

7.4.1 At the dictates of the external controls, an electrical circuit is made and the combustion air fan ("venter") runs.

7.4.2 Provided adequate combustion air flow is proved, the fan will continue to run approximately 30 sec. (pre-purge period).

7.4.3 Euro-T air heaters employ the direct burner ignition principle. A hot surface igniter will glow for ± 15 seconds, after which time the gas valve(s) will open and the burner will be lit.

7.4.4 If the burner has not lit within 5 seconds, the electronic flame relay will switch off and lockout will occur. This will cause the signal lamp to glow within the reset push-button on the appliance and/or on a remote control (if fitted). After 10 seconds the reset button on the appliance or the remote control can be activated in order to reset and restart the appliance.

7.4.5 Flame failure protection is by the ionisation principle

i.e. the ability of a suitable flame to pass an electrical current between the igniter and the earthed burner assembly. To check the flame current is adequate, remove jumper between terminal 17 and 18 on the automatic burner control, connect a DC micro ammeter between the terminals. Ionisation current should be $\geq 2\mu A$.

Note: The terminals carry mains voltage when energised.

7.4.6 Simultaneously to the ignition circuit and gas valve circuit being energised, electrical power is supplied to an anticipator within the air circulation thermal fan control. The air fan will start after about 2 minutes and warm air at a temperature of approximately 40°C is now discharged from the appliance.

7.4.7 In the event of the combustion air volume falling below a safe level, the burner will be extinguished a re-start cycle will commence after adequate combustion air volume has been restored.

7.4.8 If the burner flame is extinguished for any reason during a run cycle, an automatic attempt for re-ignition will take place, if the burner does not relight then safety shut down and lockout will occur. Manual intervention to reset is necessary to put the air heater back into service.

7.4.9 In the event of overheating for any reason, thermally activated fail safe overheat controls operate to switch off the burner.

The first control (LC1) and/or (LC2) for models 20..75/76 & 20..95/96 switches off the burner and upon its cooling, automatically resets and the lighting sequence starts automatically.

The second control (LC3) which operates at a higher temperature setting, will switch off the burner and itself set to a lockout condition which also requires manual intervention to reset to restore the heater to operational condition. A cooling time of ± 1 minute is necessary before re-setting.

7.4.10 Models 20.. 75/76 - 95/96 incorporate a thermal fuse to protect the LC 2 control in the event of flame spillage if excessive draughts exist in the zone where the air heater is installed.

7.4.11 When the set temperature or the heating time period has been reached, electrical power to the burner relay will be switched off and the burner will extinguish. The air fan will continue to run until the heat exchanger has been cooled down to a safe level.

7.4.12 To turn off the air heater for a short period,
a. turn room thermostat to lowest setting.

To relight reset thermostat.

- For prolonged period;
- turn room thermostat to low setting,
 - turn gas supply to the appliance off.
 - switch off electricity supply to the air heater **after air circulation fan has stopped**.

To relight follow lighting instructions.

- 7.4.13 The gas service tap must only be operated in emergencies, for servicing or prolonged periods of shutdown of the air heater.

SECTION 8. MAINTENANCE

- 8.1 Before commencing servicing, turn off the main gas supply and switch off the main electricity supply **after the air circulation fan has stopped**.
- 8.2 It is recommended that maintenance is carried out at least once a year. More frequent servicing may be required dependent upon the environmental circumstances where the air heater is installed. Regular inspection is necessary, especially in dirty areas, to assess the servicing frequency.
- 8.3 Check condition and security of flue and combustion air system.
- 8.4 Check for security and worthiness of the suspension or mounting system.
- 8.5 **To gain access to the controls and flue gas fan assembly.**
- 8.5.1 For appliances fitted with vertical flue systems, refer to figure 6. Follow the four step procedure:
- 1. Unlatch cam fastener $\frac{1}{4}$ turn counter clockwise on controls compartment access panel.
 - 2. Remove access panel.
 - 3. Unscrew retaining screw at top of upper cover panel.
 - 4. Upper panel can now be removed by pushing upwards 2 cm to disengage panel retaining lugs and then lifted away.
 - 5. The flue installation should include a service access section adjacent to the connection socket allowing access to the top of the flue fan. In the event that the fan housing assembly requires removal i.e. for replacement, then it is necessary to remove that section to access the 4 securing screws that fasten the fan housing through the top of the appliance. All controls, electrical and flue gas components are now accessible.
- 8.5.2 For appliances fitted with horizontal flue systems: follow steps 1 & 2 above and then;
- 1. Disconnect flue and combustion air inlet pipes at the section provided. Ensure that the pipes will remain supported when disconnection has been made.
 - 2. Remove 4 sheet metal screws securing the venter fan to the upper cover panel.
 - 3. Follow steps 3 & 4 8.5.1 above.
- 8.5.3 To replace reverse order above as appropriate.
- 8.6 If it is necessary to remove the cabinet top panel to gain access to the flue products collector box or the top of the heat exchanger, it is necessary to:
- 1. Isolate and disconnect the electrical and external controls wiring that passes through the panel.
 - 2. Isolate and disconnect the gas service to the air heater.
 - 3. Remove all of the sheet metal screws that secure the top panel to the appliance and remove panel as required.
- 8.7 Remove all dust and dirt from the combustion air fan (venter) see fig. 8 If dismantling venter observe critical dimensions before reassembly.
- 8.8 Check that air circulating fan guard is undamaged and secure.
- 8.9 Check security of the fan blade and fan motor. **Note:** The fan motor is lubricated for life and does not require lubrication.
- 8.10 Inspect hot surface igniter fig.7 replace if in doubt about its condition. **Note: The Igniter device is fragile, therefore, handle carefully**
- 8.11 Inspect and clean the burner assembly, refer to fig.9
- 8.12 Inspect heat exchanger and clean as necessary. This can only be done after removing the burner assembly.
- 8.13 After removal of burner assembly, each element of the heat exchanger can be cleaned by use of a soft brush and compressed air. Clean both inside and the outside surfaces.
- 8.14 Clean burners and gas jets with soft brush and compressed air. To prevent damage, do not use hard objects for cleaning the gas injectors
- 8.15 If anchor lines of service panels are removed for servicing, they **must** be replaced upon completion.
- 8.16 **Upon completion of any servicing re-commission the appliance in accordance with the step procedure described in section 7.7.2 of this document.**

Fig. 6 SERVICE ACCESS KEYS

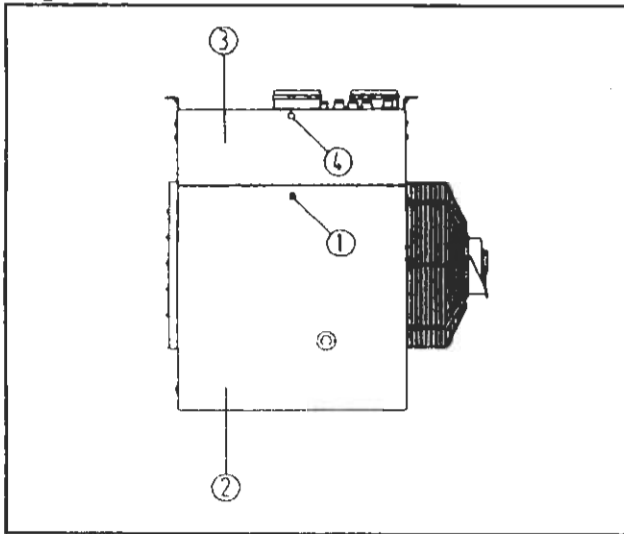

Fig.7 IGNITER ASSEMBLY

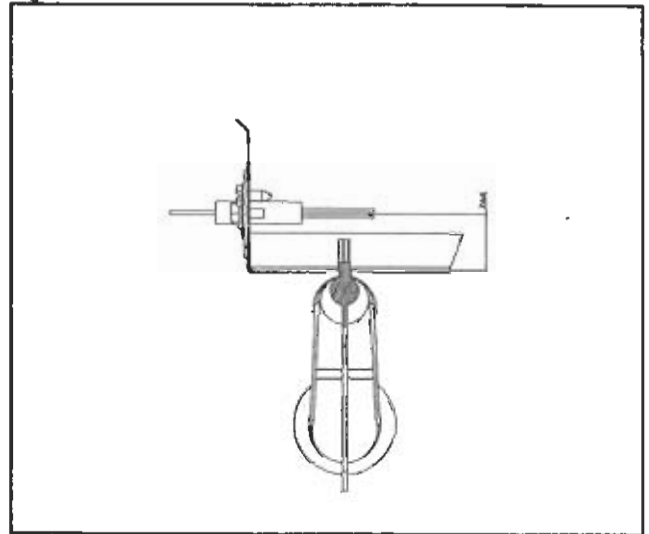
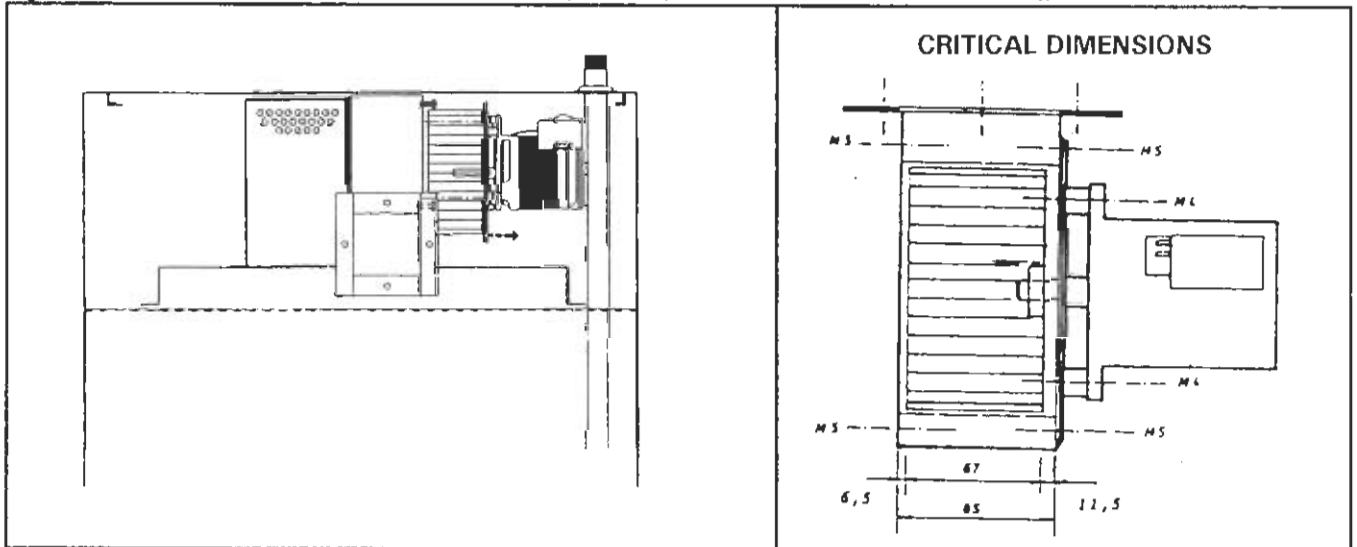

Fig. 8 REMOVAL OF COMBUSTION AIR FAN (VENTER) MOTOR FAN IMPELLER ASSEMBLY



8.15 TO REMOVE COMBUSTION AIR FAN:

1. Disconnect electrical connections to motor.
2. Remove motor and venter wheel (3 screws).
3. Withdraw motor/impeller assembly sideways.

4. Clean venter housing.
5. Check, clean or replace motor and/or venter wheel.
6. Replace in reversed order after checking critical dimensions (fig. 8)

Fig. 9 REMOVAL OF BURNER ASSEMBLY

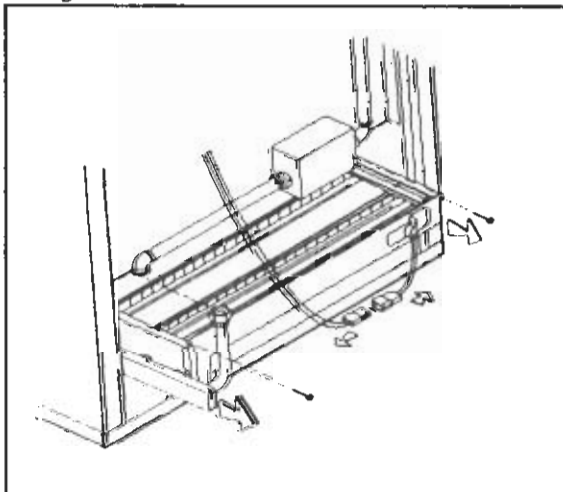

TO REMOVE BURNER ASSEMBLY:

1. Turn off the main gas supply.
2. Switch off the main electricity supply after air circulation fan has stopped.
3. Open service panel fig.6.
4. Disconnect wires of igniter.
5. Disconnect union fittings between gas valve(s) and burner.
6. Unscrew fixing screws of burner and pull forward burner assembly on it's slide rails.
7. Replace in reversed order

Figure. 10

COMPONENT PARTS LAY OUT

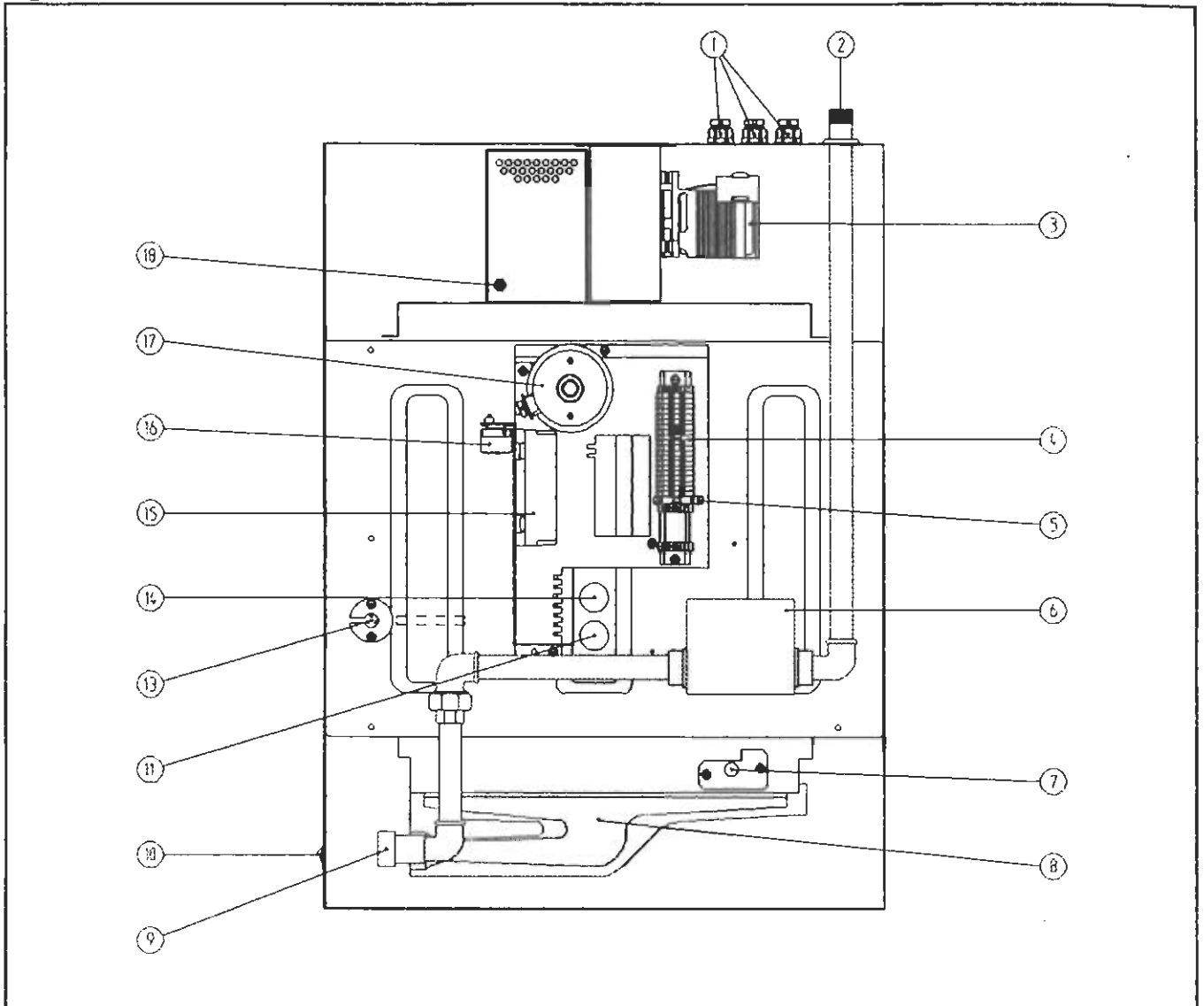

Legend:

- | | |
|---|--|
| 1. Cable entry all electrical connections | 11. Fan thermostat (FCR) |
| 2. Gas connection 3/4" (not supply line size) | 12. Not used for UK! |
| 3. Combustion air fan with motor | 13. Bulb of thermal overheating and seal/grip (LC3) |
| 4. Terminals for all electrical connections | 14. Thermal overheating control (LC1) + (LC2 20..75/76 & 95/96 opposite side only) |
| 5. Fuse | 15. Burner relay |
| 6. Double gas valve with pressure regulator | 16. Thermal overheating control (LC3) |
| 7. Hot surface igniter | 17. Differential switch |
| 8. Burner tray with burner ribbons | 18. Differential pressure reference point nipple |
| 9. Manifold with injectors and pressure nipple | |
| 10. Reset button with indicator for burner relay lock-out | |

THE APPLIANCE WILL ONLY OPERATE WITH ALL PANELS CORRECTLY FITTED !!

SECTION 9. FAULT FINDING

9.1 Burner does not ignite

- Thermostat set too low or time switch not correctly set; no power to terminals 2 and 5.
- Fuse F3 has blown; no power to terminal 2 and LC3.
- Reference tube to differential air pressure switch S3 is not airtight or blocked.
- Faulty differential air pressure switch S3; no power to terminals 2 and 13.
- Insufficient differential pressure in flue pipe system; Flue blocked or too long.
- Burner relay in lockout (point 2 below) or faulty.
- Faulty combustion air fan M3 (venter).
- Faulty limit control LC1/LC2; no power to terminal 2 and ¹⁾LC1/LC2.
- Overheat control LC3 in lockout; no power to terminal 2 and LC3; Reset manually.

9.2 Flame relay in lockout

- Air in gas service; purge.
- Low gas pressure.
- Faulty hot surface igniter.
- Faulty differential air pressure switch.
- Gas valve does not open; no power to terminals 2 and 7.
- Insufficient ionisation flame current; ionisation current > 2 μ A.
- Incorrect wiring of mains input line, neutral, earth.

9.3. Combustion air fan (venter) does not start

- Faulty motor or capacitor.
- Faulty burner relay.
- Differential air pressure switch S3 still in normal run position no change-over.
- Faulty fuse F3.

9.4 Differential air pressure switch switches burner off

- Switch-point should be; ON: 1,02 mbar, OFF 0,94 mbar, except type..25/26: should be ON: 0,76 mbar, OFF 0,68 mbar.
- No differential pressure in flue gas system; check flue and air inlet.
- Faulty combustion air fan or capacitor.

9.5 Appliance does not provide sufficient warm air

- Check gas inlet pressure.
- Check burner pressure.
- Gas filter (if fitted) dirty or blocked.
- Limit control LC1/LC2 switches burner off (see 9.6).

- Differential pressure switches relay off (see 9.4).

9.6 Limit control LC1/LC2 switches burner off

- Switch temperature 51,5°C, ..55/56....95/96 top connection: 63°C.
- Insufficient air flow.
- Vertical and horizontal louvres set in closed position.
- Burner overload, check burner and inlet gas pressure.
- Fan control switch faulty
- Check fan rotational direction.
- Air temperature at fan inlet too high; T max. 30°C (see 9.6).
- Thermal contact in fan motor switches off intermittently.

9.7 Limit control LC3 switches

- Switch temperature 96°C (+0/-5).
- Check location and security of capillary and probe.
- Air discharge temperature too high (see 9.6).
- Faulty limit control LC1/LC2.
- Air fan stops immediately after burner is switched off; incorrect control/s wiring.
- Faulty fan control (FC).

9.8 Air fan does not start

- No power to terminals 2 and 11.
- Faulty fan control (FC).
- Faulty motor or capacitor.
- Thermal over-load in motor switching.

9.9 Fan starts and stops intermittently while burner is on.

- Faulty heat anticipator (FCR) in fan switch.
- Thermal over-load in motor switching.
- Inlet ambient air temperature too low; T min. < 5°C.; will correct as space temperature rises.
- Faulty wiring connection; loose terminals!

¹⁾ LC2 Applies to models Euro-T..S 75/76 & 95/96 only

SECTION 10. SPARE PARTS LIST

10.1 GAS SECTION

DESCRIPTION	PART NUMBER	MFGS. REF.	APPLICATION
Gas valve single stage burners	03 25250	SIT 830 Tandem	2..25/26 - 2..35/36
Gas valve single stage burners	03 25136	H'well VR4601AB	2..45/46 - 2..95/96
Gas valve two stage burners	03 35136	H'well VR4601BP	Two stage options

10.2 ELECTRICAL SECTION

DESCRIPTION	PART NUMBER	MFGS. REF.	APPLICATION
Thermal fan control	03 25166	TOD29T12 (250V)	All
Thermal over-heat control (limit) LC1	03 24970	TOD60T11	All
Thermal over-heat control LC3	03 24959	Limit 96° C	All
Combustion fan motor 7 wheel assy.	36 79090	Drouard-tec CP 78	All
Combustion circuit pressure switch	30 30607 68	Honeywell C6065 FH1144	All except 2.25/26
Combustion circuit pressure switch	30 60607 94	Honeywell C6065 FH1193	Models 2.25/26 only
Automatic burner control	03 25317	Honeywell S4570LS	All
Hot surface ignition device (assembly)	05 25217	Norton 240V	All
Two pole relay K1.2	30 61738 240V	Omron G7L2A	All two stage burners
Capacitor fan motor	01 25600 04 mf	4 mfd 400V	All
Wiring harness for burner control	06 41631 HGC	----	All
Wiring connector for igniter device	06 41531 HGC	----	All
Wiring harness for two stage burners	06 41621	----	All
Wiring terminals	06 41635	Entrelec	All

10.3 AIR HANDLING SECTION

DESCRIPTION	PART NUMBER	MFGS. REF.	APPLICATION
Fan motor 1/10	01 25602 01	RIBX 125/E/AR 1/10	2..25/26
Fan motor 1/6	01 25620 01	RIBX 327/E/AR 1/6	2..30/36 - 2..55/56
Fan motor 1/6 2 x	01 25620 01	RIBX 327/E/AR 1/6	2..75/76 & 2..95/96
Axial fan	02 25702	N4 - 305 - 28 - ½	2..25/26
Axial fan	02 25704	N4 - 381 - 34 - ½	2..30/31
Axial fan	02 25709	N4 - 457 - 34 - ½	2..35/36 - 2..55/56
Axial fan 2 x	02 25712	N4 - 16 - 34 - ½	2..75/76
Axial fan 2 x	02 25709	N4 - 457 - 34 - ½	2..95/96

10.4 MISCELLANEOUS

DESCRIPTION	PART NUMBER	MFGS. REF.	APPLICATION
Combustion air fan impeller	02 25728	Punker	All
Suspension sockets 1" BSP (R1)	35 20003 2000	Al (= 8 pcs)	Options
Sampling pressure test point	07 25811 02	M8	All
Silicon tubing	06 20224 cm	φ 5-8 mm x 1.0 m	All
Combustion fan assembly gasket	11 44696	---	All
Capillary seal gasket	06 07726	---	All
Capillary seal plate	08 07727	---	All

SECTION 11. GAS CONVERSION

- 11.1 This air heater is designed to operate on natural, propane or butane gas and will be supplied as ordered for the gas type specified. In the event it is required to convert to a different gas type to that which has been supplied, conversion of the gas burner must be carried out.
- 11.2 A Reznor approved conversion kit to suit the appropriate gas type must be used.
- 11.3 In addition to changing the burner injectors, and adjusting the gas pressure sealing a governor or fitting a blanking plate it is necessary to fix over stickers as supplied with the conversion kit of parts.
- 11.4 After conversion re-commission appliance according to section 7 of this document.

Figure. 11 BURNER AIR SHUTTER AND SETTING DIMENSION for all GASES UK & IE

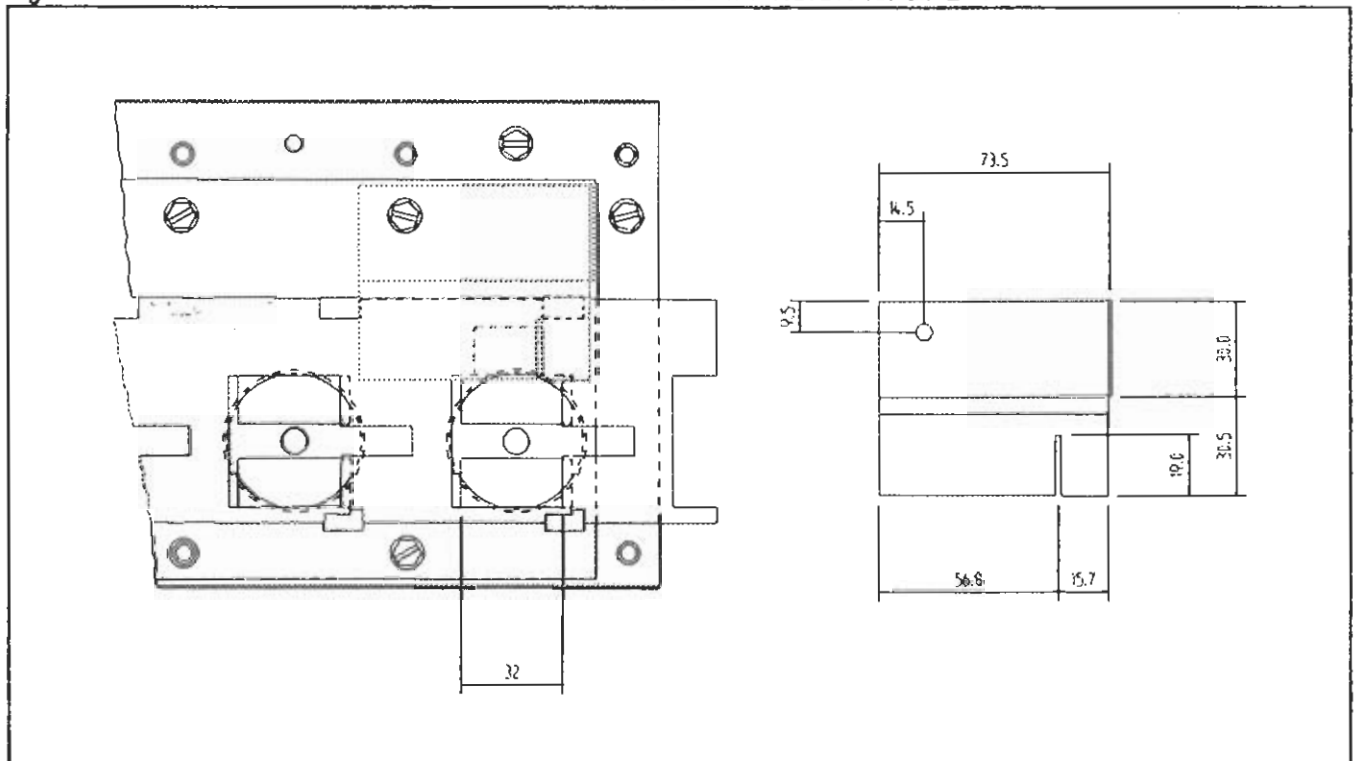

Reznor® EURO-T 2000 S

ONE OF A Reznor GENERATION OF CE MARKED GAS FIRED ENERGY
EFFICIENT AIR HEATERS

BEST USED WITH Reznor OPTIONAL ELECTRONIC CONTROL PANELS
SAVE ENERGY AND OPTIMISE THERMAL COMFORT

Reznor »Europe N.V.
J&M Sabbestraat 130
B8930 Menen
Belgium

Tel: + 32(0)56 52 95 11
Fax: + 32(0)56 52 95 33
e-mail: reznor_europe@tnb.com

Reznor UK Limited
Park Farm road
Folkestone
Kent
CT19 5DR

Tel: + 44 (0)303 259141
Fax: + 44 (0)303 850002
e-mail: sales@reznor.co.uk

The logo for Thomas & Betts, featuring the company name in a stylized, bold font with a registered trademark symbol.