

GAS FIRED AIR HEATERS TYPE EURO-X 1000 A

Axial Fanned Forced Convection Appliances with
Thermal Electric Burner Control for use as:
Type B11 Open flued Appliances

May be used with Reznor "Euroventer" Flue Gas Fan as:
Type B14 Appliances

These Air Heaters are not designed for use with ducting for circulation air distribution

This document applies to EURO-X appliances with:
Thermoelectric or Hot Surface Ignition burner controls

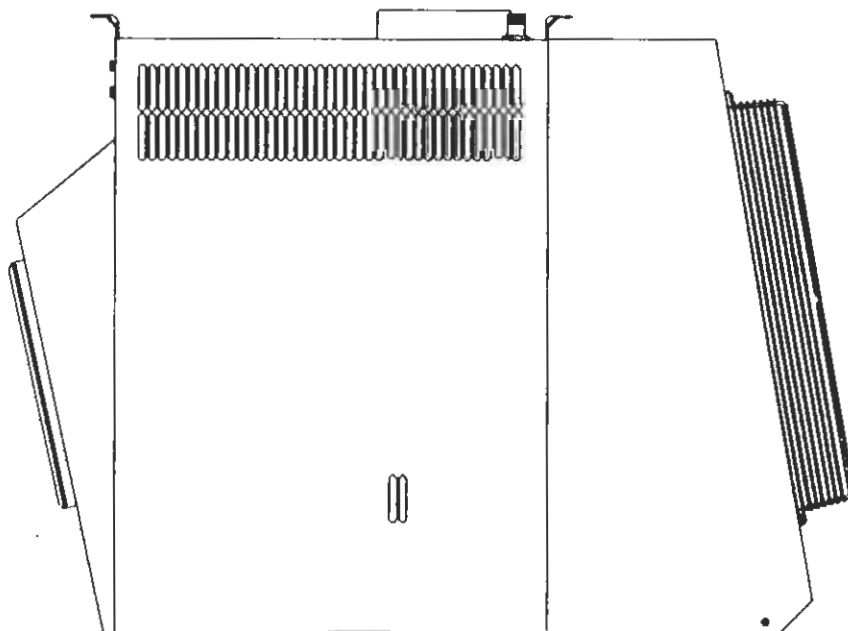

These appliances meet the following EC Directives:

Dir. CE 90/396/EEC	GAD
Dir. CE 89/336/EEC	EMC
Dir. CE 89/392/EEC	MD
Dir. CE 73/ 23/EEC	LVD

Please read this document carefully before commencing the installation and leave it with the user or attached to the appliance or gas service meter after installation.

INDEX

	Page
1. General	2
2. Technical data	3
3. Dimensions	4
4. Installing	5
5. Air supply requirements	6
6. Flue system	7
7. Gas connection	9
8. Electrical connection	9
9. Commissioning	10
10. Servicing	13
11. Short parts listing	18
12. Gas conversion	19
13. Fault finding	20
14. Health and Safety information	21
15. User instructions	22

N.B. If optional equipment is supplied with this appliance please refer to the additional instructions supplied with the option.

SECTION 1 GENERAL

- 1.1 Before installation, check that the appliance as described on the packaging label is in accordance with the correct type and model as specified on the data plate and complies with your customer order.
- 1.2 After unpacking the appliance, leave it fastened to the wooden pallet until it has been suspended or until just before base mounting. This affords protection to the painted underside which is normally exposed to view after installation.
- 1.3 Please read this document before commencing installation.
- 1.4 These instructions are only valid for the country of use indicated on the appliance i.e.: GB - IE. If these symbols are not shown, it is necessary to obtain appropriate technical instructions which will provide information concerning the necessary modification of the appliance for the conditions of use in the country concerned. Such instructions may be obtained upon request from your supplier.
- 1.5 Check that the local distribution conditions of electricity supply, type of gas and pressure, and adjustment of the appliance are compatible.
- 1.6 When installed in Great Britain the total installation must comply with the requirements and recommendations of British standard BS 6230 1991. "Installation of Gas Fired Forced Convection Air Heaters for Commercial and Industrial Space Heating".
The installation must also be in accordance with the relevant requirements of "The Gas Safety (Installation and Use regulations) and (Amendment Regulations 1990)" and The "Building" and "Electrical Regulations" (in GB the IEE Regulations). The requirements of the "Local Building Standards Office", the premises "Insurance" undertaking and the "Fire Office" must also be observed.
- 1.7 Unauthorized modification of this appliance or departure from use in the manner for which it was intended by the manufacturer or installation in a manner contrary to these instructions, may constitute a hazard and jeopardize all warranties. Deviations should only be carried out after formal consent has been obtained from the manufacturer.
- 1.8 Ensure the environment in which the air heater will be installed will not create a hazard i.e. where excessive (volatile) dust, flammable or corrosive substances and/or vapours and combustible materials may be present.
- 1.9 These appliances have been tested, and set according to the data plate before leaving the factory.

SECTION 2. TECHNICAL DATA

Table 1. APPLIANCE DATA

Type EURO-X ...		1025A	1030A	1035A	1045A	1055A	1075A	1095A	
Gas category 'Cat.'		II _{2H3+}							
Air supply and flue type		B11 or B14 ¹							
Heat input (Hs) 'Qn'	kW	30,28	34,94	43,26	52,00	64,67	88,96	118,7	
Heat input (Hi) 'Qn'	kW	27,30	31,50	39,00	46,90	58,30	80,20	107,0	
High heat output	kW	23,8	27,5	34,2	40,8	50,8	69,9	93,2	
Number of jets		4	5	7	9	12	16		
Jet size	natural gas	ø mm	2,4	2,2	2,4			2,6	
	propane/butane	ø mm	1,35	1,30	1,25	1,35		1,40	
Gas supply pressure 'P' ²	natural gas	mbar	(GB) - 17,5 (IE) - 20,0						
	propane	mbar	37,0						
	butane	mbar	28,0						
Burner pressure	natural gas	mbar	8,4						6,0
Gas consumption	natural gas ³	m ³ /h	2,89	3,33	4,13	4,96	6,17	8,49	11,33
	butane G30	kg/h	2,21	2,55	3,15	3,80	4,72	6,49	8,66
	propane G31	kg/h	2,16	2,49	3,09	3,71	4,62	6,35	8,48
Gas service connection (not supply line size)		Rc ¾							
Electrical service (protection class IP 20)		230/240V 1 N ~ 50 Hz							
Temperature rise ΔT (± 1)	K	28	27	26	30	27	29	32	
Air volume @ 15 °C	m ³ /h	2500	3100	4000	5600	7300	8700		
Mounting height ⁴	m	3,00 - 3,50		3,25 - 3,75		3,50 - 4,00			
Throw (terminal V ₀ to 0,5 m/s) ⁵	cm	26		31		32	37	46	
Sound pressure level L _p ⁶	dB(A)	55	56	55	59			60	
Fan motor rating	kW	0,2	0,23	0,24	0,40	0,37	0,56		
Total electric rating ⁷	kW	0,35	0,38	0,40	0,58	0,53	0,70		
Weight net	kg	81	95	112	130	165	180		
Weight shipping	± kg	100	116	138	159	200	215		

- 1 Category B14 only applies when used with a Reznor "EUROVENTER" flue gas fan
- 2 Maximum gas pressure at inlet to appliance = 50,0 mbar
- 3 Natural gas G 20, calorific heating value 10,48 kWh/m³ on Hs @ 15 °C & 1013 mbar
Propane G 31, calorific heating value 14,0 kWh/kg. Butane G 30, calorific heating value 13,7 kWh/kg
- 4 To underside of air heater
- 5 Isothermic condition (20 °C)
- 6 At distance of 5.0 m, Q = 2, A = 160 2m², louvres no deflection, isothermic condition,
- 7 Total electrical rating for appliances with hot surface ignition is exceeded by 130 W for ± 30s at start up

Figure 1.

DIMENSIONS

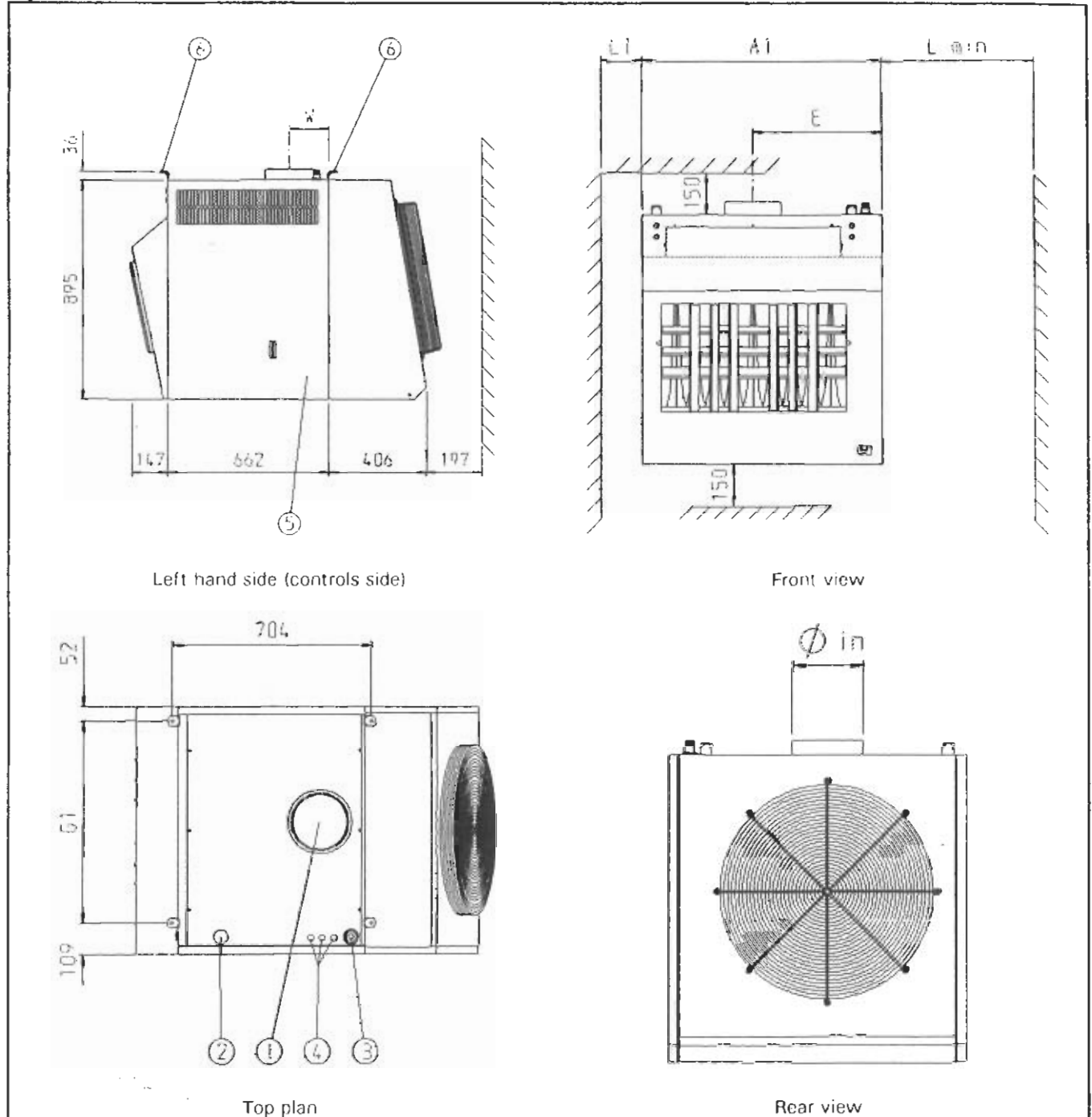

Legend figure 1.

- | | | | |
|---|--|---|---|
| 1 | Flue socket | 4 | Electricity & Controls connection point |
| 2 | Gas connection Thermo-electric burners | 5 | Burner & controls access panel |
| 3 | gas connection hot surface ignition system | 6 | Suspension points |

Table 2. DIMENSIONS REFERENCE FIGURE 1

MODEL	EURO-X ...	1025A	1030A	1035A	1045A	1055A	1075A	1095A
A1 Width overall		520	590	730	730	870	1080	1360
Flue internal ϕ	mm	130	153	181	181	202	202	252
G1 Width of suspension points centres		359	429	569	569	709	919	1199
W Centre of flue to reference point		127	137	151	151	162	162	169

SECTION 3 INSTALLING

3.1 The EURO-X 1000 A air heater may be installed in a suspended manner using the suspension points provided through the top of the appliance. Suspension brackets which may be used for base mounting are available as optional items. Ensure that the air heater is secured to any base mounting arrangement.

Ensure that the structural elements of the building are adequate to carry the weight of the appliance and its ancillary components i.e. the flue system. After suspension the appliance should be rigid so as not to impose a strain on the services connected to the appliance.

3.2 Ensure that sufficient space around the air heater is maintained for servicing and that the appliance is not sited where it

may suffer from damage by, e.g. fork lift trucks.

3.3 Adequate clearance from combustibles materials must be maintained between the appliance and its flue system.

3.4 The appliance must be installed in a level plain both laterally and horizontally.

3.5 EURO-X series air heaters are open flued natural draught appliances, it is therefore, important that they are installed in a draught free zone i.e. away from doors etc. Consideration must be given to the effects that any power extraction might have on the buildings natural pressure condition. The appliance flue will act as a pressure relief in the event that a negative pressure exists within the space where the air heater is installed.

Figure 2 CLEARANCES SUSPENSION and MOUNTING ARRANGEMENTS

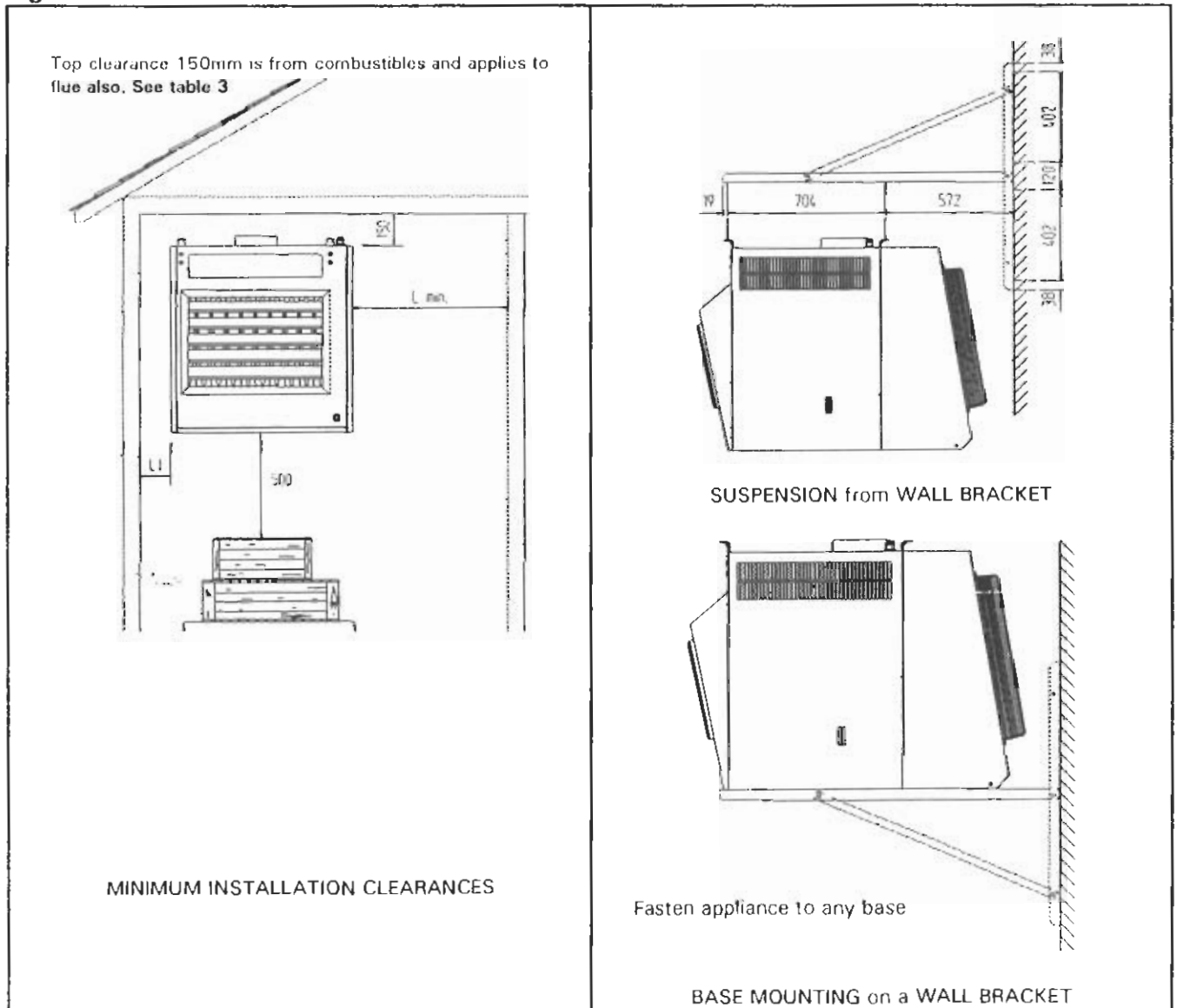

Table 3

DIMENSIONS REFERENCE FIGURE 2

EURO-X 1000 A	1025A	1030A	1035A	1045A	1055A	1075A	1095A
L minimum	550	620	750		900	1100	1400
L1 Opposite side	150						

SECTION 4 AIR SUPPLY for COMBUSTION & VENTILATION

4.1 It is essential that sufficient fresh air is provided for combustion and room ventilation. Most traditional building constructions have a natural air change rate of at least 0.5/h. Where it is known that the air change rate is at least 0.5/h and where the volume of the heated space is greater than 4.7m³ per kW of total rated heat input, additional ventilation is not required.

4.2 Table 4. Building volume limits for Reznor EURO-X 1000 Air Heaters based upon 4.7m³ per kW of rated heat input for one air heater only.

EURO-X Model	Heat Input kW	Room Volume m ³
1025 A	30.28	142
1030 A	34.94	165
1035 A	43.26	203
1045 A	52.00	245
1055 A	64.67	304
1075 A	88.96	418
1095 A	118.70	558

If the minima volumes stated above exist together with appropriate similar allowances for other combustion plant that may be installed in the same space or zone, then additional ventilation is not required.

4.3 Where it is known that the air change rate is less than 0.5/h or where the building volume is less than 4.7m³ per kW of heat input, ventilation grilles must be provided at low level i.e. below the level of the appliance flue connection. In cases where doubt exists over the air change rate ventilation should be provided.

For air heaters of heat input less than 60 kW the total minimum free area shall not be less than 4.5 cm² per kW of total rated heat input as table 5 below.

For our heaters of heat input 60 kW or more the total minimum free area shall not be less than 270 cm² plus 2.25 cm² per kW in excess of the 60 kW rated heat input.

4.4 Table 5. Air Supply Requirement for Combustion & Ventilation.

EURO-X Model	Heat input kW	Low level cm ²	
≤60 kW	1025 A	30.28	140
	1030 A	34.94	160
	1035 A	43.26	200
	1045 A	52.00	240
≥60 kW	1055 A	64.70	290
	1075 A	88.95	340
	1095 A	118.70	410

Note : Ventilation grilles must be installed so that air is drawn directly from outdoors. In the event that communication from the space where the heater is installed to outdoors is via another room then the route to outdoors must be ducted through the communication area.

The grille velocity for all air supply must not exceed 2.0 m/s. Grilles should be sited where they cannot easily be blocked or flooded. Notices should be provided advising about the need to keep air supply grilles unobstructed.

4.5 Where mechanical ventilation is used it shall be by mechanical inlet with either mechanical or natural extraction. Automatic means of control such as interlocks must be provided. The function of other ventilation plant in the zone must be taken into account. At no time should it be possible to create a negative pressure in the zone as this will lead to a hazardous situation whereby the air heater flue will act as a pressure relief.

4.6 Normally EURO-X 1000 A air heaters are installed within the room or space to be heated. If it is necessary to install the air heater in a separate room and blow the air into an adjoining room, then a short duct not exceeding 1.0 metre may be used to connect the appliance to the air discharge louvre as shown in figure 3.

Figure 3. INSTALLING IN AN ADJOINING ROOM

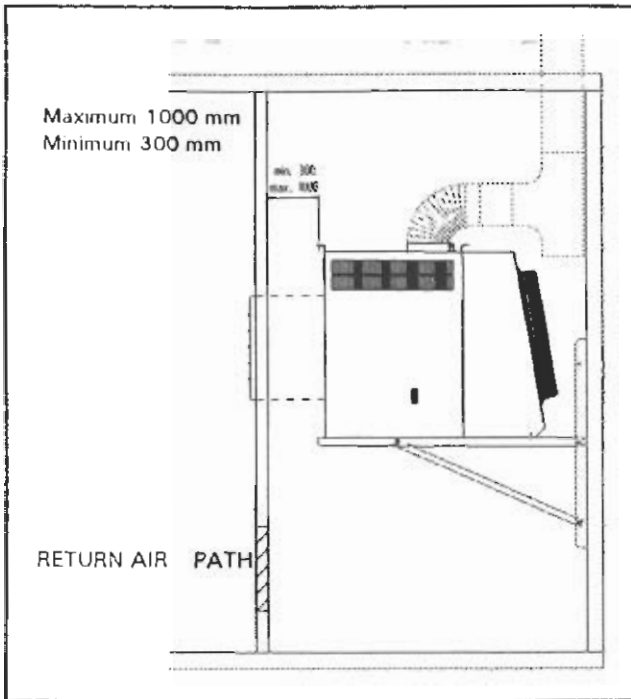

A return air grille must be provided to ensure that an unobstructed path for re-circulation; air back to the air heater is maintained, this is to ensure that a negative pressure cannot develop

within the space where the air heater is installed. Grilles sized in accordance with table 6 must be installed at **low level**. The sizes stated must be regarded as the **minimum** free area size to be fitted. Such grilles should be situated as low as possible in the dividing wall and in a location where they are unlikely to become obstructed. It is recommended that a guard be fitted to prevent obstruction i.e. stored materials.

Permanent notices should be fixed in a prominent location on **either side** of the grille worded, "This grille must be **kept clean** and unobstructed at all times".

Table 6. RETURN AIR GRILLE SIZES

EURO-X model	Air volume m ³ /h	Grille size CM ²
1025 A	1 700	2 400
1030 A	2 400	3 400
1035 A & 1045 A	3 700	5 200
1055 A	4 200	5 900
1075 A	5 600	7 200
1095 A	7 900	11 000

SECTION 5 FLUE SYSTEM

5.1 EURO-X series air heaters must be connected to a flue system venting the products of combustion directly to outdoors.

Flue systems must be installed in accordance with the rules in force taking into account the location of flue termination relative to the construction elements of the building, i.e. windows, roof levels, etc., and in accordance with statutory requirements.

5.2 The products of combustion may reach a temperature of 230 °C. Reznor recommend that appliances are connected to individual flues sized in accordance with the diameter appropriate to the appliance flue connection socket.

Flues must be terminated with an approved terminal fitting.

5.3 A minimum overall length of 2.0 m is required to ensure a good flue draught condition.

5.4 Where it is necessary to flue more than one appliance into a common flue as fig.6 then the flue should be sized in accordance with the following formula:

$$D_1 = \sqrt{D_2^2 + 0.5D_3^2}$$

Where:

- D₁ = new flue size required
- D₂ = diameter of largest flue
- D₃ = diameter of additional flue

Never connect an additional flue to a main stack at a 90° angle an inverted Y piece must be used.

5.5 It is not recommended to install the flue directly into the appliance flue socket but to use a stopped tee piece following a bend off of the air heater. This practice prevents ingress of water into the appliance and affords the facility to connect to a drain to evacuate water and condensation should this occur.

Figure 4 shows the method recommended.

5.6 If it is necessary to include horizontal runs of flue within the system, then the horizontal section of flue should be installed with a positive rise away from the appliance of at least 1° or 17 mm per metre run until the vertical section.

A vertical rise from the appliance to the terminal point of 2.0 X the horizontal length must be maintained as indicated in figure 5.

- 5.7 The use of twin wall flue should be considered if condensation in the flue system is a possibility.
- 5.8 Difficult flues may require a Reznor "EUROVENTER" flue gas fan in the installation.

Figure 4. RECOMMENDED FLUE CONNECTION

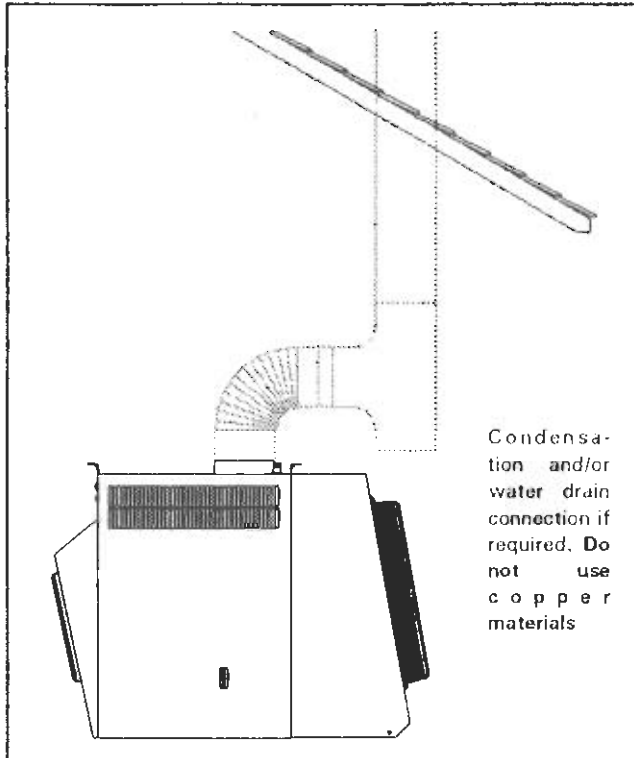

Figure 5. HORIZONTAL FLUE CRITERIA

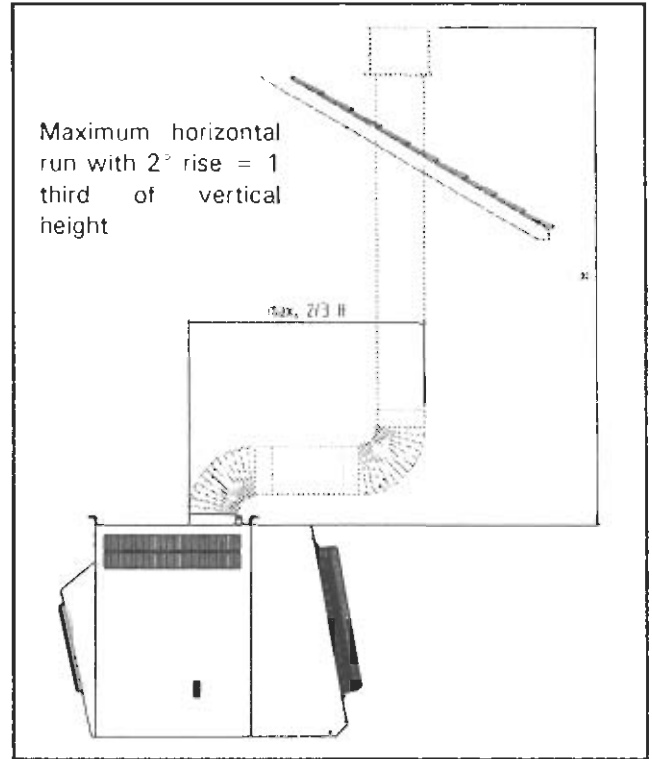
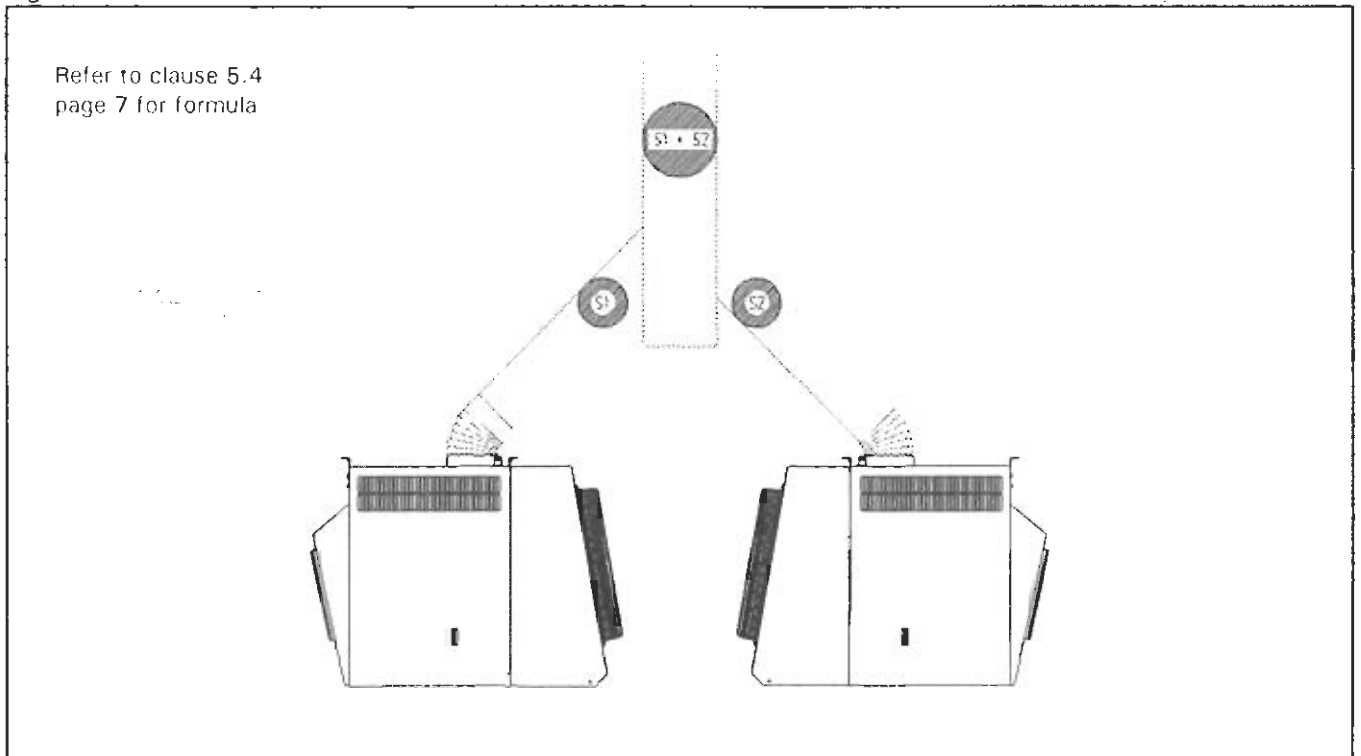

Figure 6. COMMON FLUE SYSTEMS



SECTION 6 GAS CONNECTION

- 6.1 Connection to a gas service may only be carried by suitably qualified persons. The gas installation must comply with the rules in force using materials appropriate for gas service installations.
- 6.2 Check that the gas category is in accordance with the data described on the air heater.
- 6.3 An adequate gas supply sized to provide the dynamic pressure for the volume required by the air heater(s) is essential to maintain the nominal heat input.
- 6.4 A 90° action gas service tap and, to facilitate servicing, a disconnect union fitting must be provided adjacent to the appliance, see figure 7.
- 6.5 Ensure that a gas service includes a filter and has been tested and purged in accordance with prescribed practice prior to commissioning and taking the air heater into service.

Fig. 7 GAS CONNECTION DETAIL

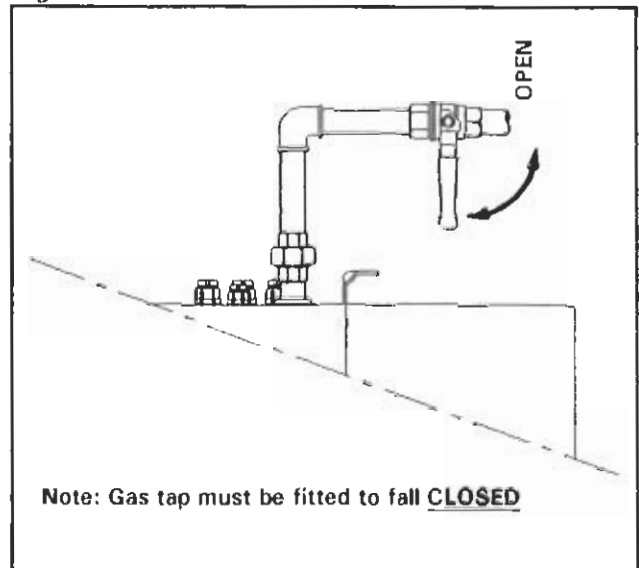

WARNING: NEVER use a FLAME to test for GAS Soundness !!!

SECTION 7 ELECTRICAL CONNECTION

- 7.1 The Electrical installation may only be carried out by suitably qualified persons observing the rules in force.
- 7.2 Check that the electrical specification is in accordance with the specified data on the air heater. A unique appliance wiring diagram is supplied as a separate document attached to this one, plus an additional copy is attached to the air heater.
- 7.3 These appliances **must** be earthed.
- 7.4 A separate lockable electrical isolator for each heater must be provided within view of any person working on the appliance and adjacent to it.
- 7.5 Ancillary controls are required to provide timed heat cycles, room comfort temperature level, frost protection, over-ride air circulation, etc. **These** are not included with the appliance and **should** be ordered separately.
- 7.6 Ensure when planning the external appliance control circuitry, that power will be supplied at **all times** to the air heater, even when it is control **switched** in the 'heat-off' mode. This is necessary to ensure that the fan can operate independent of the heating control. Therefore, **Never** incorporate automatic controls that electrically isolate the appliance.

The isolator **must** have a contact separation of at least 3.0 mm on all poles.

NOTE: EURO-X 1000 A AIR HEATERS ARE SUPPLIED WITH EXTERNAL CONTROL CIRCUITS BRIDGED. THE AIR HEATER/S WILL OPERATE CONTINUOUSLY UNLESS THESE ARE REMOVED AND TIME AND TEMPERATURE CONTROLS SUBSTITUTED FOR THEM

SECTION 8 COMMISSIONING, LIGHTING AND OPERATION

COMMISSIONING

8.1 Normally Reznor EURO-X 1000 A air heaters do not require commissioning. Final testing after production ensures that: **If installation has been carried out strictly in accordance with this document**, the appliance is ready to be taken into service.

- 8.2 Checks to ensure;
- earth continuity
 - resistance to earth
 - phase supply to correct terminals
 - current rating and fuse value
 - correct supply gas pressure
 - correct burner gas pressure
 - satisfactory & smooth ignition
 - flue system is venting the products of combustion to outdoor atmosphere, must be made.

8.3 In addition to the above requirements checks to ensure that the fan/s rotate freely and in the correct direction and the fan guards are fitted correctly and securely.

8.4 **Euroventer:**
Installations may include a Reznor Euroventer. This device is an electrically powered fan fitted into the flue system. Its inclusion will be obvious. **When a Euroventer is fitted the control switching of the air heater as described in 8.9 is via the Euroventer, which is operationally proven prior to the burner control being activated.**

8.5 LIGHTING THERMOELECTRIC

Models EURO-X 1000 A 1025 - 1045

- Ensure that the air discharge louvres are set to an open position;
- Turn **ON** the gas supply to the air heater;
- **Switch ON** the electricity supply to the air heater;
- Set room thermostat or remote control to an **OFF** setting;
- If fitted ensure that a time control is at an **ON** setting;
- **Observe** gas control details from figures 8 set control to star position:
Using a lighted taper or match depress and hold the control valve start knob and apply light to the ignition burner. When the ignition burner has lit, hold control for 30 seconds. Ignition burner should remain alight when released. Turn knob to "Flame" position.

NOTE:

- If ignition burner has not lit wait five minutes and repeat the lighting procedure
- Having established the ignition burner set

- control to "**Flame**" position, appliance operation is now fully automatic;
- Set room thermostat to call for heat and/or adjust to the desired comfort level. The pilot burner will now light the main burner.
- In the event that the pilot flame goes out for any reason it is important to wait five minutes before attempting to relight the gas due to the possibility of main gas flowing from the main burner if the thermocouple has been energised.
- To stop the burner, put the control knob to the **OFF** position as indicated. It must be noted there is a security interlock which prevents relighting for one minute.

Figure 8.
GAS CONTROL TYPE EURO-X 1000 A 1025 - 1045

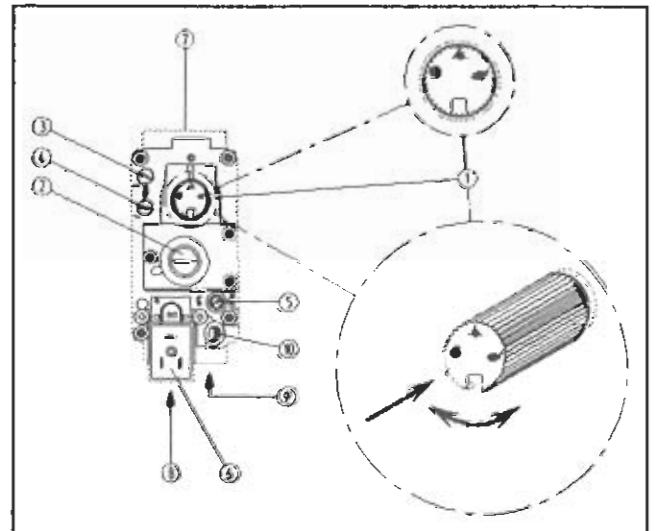

Legend figure 8:

- | | |
|----|-----------------------------------|
| 1 | Control knob |
| 2 | Governor |
| 3 | Inlet gas pressure test point |
| 4 | Burner pressure test point |
| 5 | Pilot gas throttle screw |
| 6 | Main burner electrical connection |
| 7 | Gas inlet |
| 8 | Gas outlet |
| 9 | Pilot gas line connection |
| 10 | Thermocouple connection |

8.6 LIGHTING THERMOELECTRIC

Models: EURO-X 1000 A 1055 - 1095

- Ensure that the air discharge louvres are set to an open position;
- Switch **OFF** the electricity supply to the air heater;
- Turn **ON** the gas supply to the air heater;
Set room thermostat to **OFF** or its lowest setting;
- Observe gas control details from figure 9 note start gas position;
- Using a lighted taper or match, depress the control valve start button and apply light to ignition burner. Keep start button depressed for ± 20 seconds after the ignition burner has lit;
- Close burner compartment access panel/door;
- Switch **ON** the electricity supply to the air heater;
- adjust room thermostat to desired temperature or adjust other external controls to requirements of timing and temperature.

Important:

If pilot flame fails to light or goes out for any reason allow 3 minutes before re-lighting. This time must also be allowed before re-ignition if there is a failure of the main burner for any reason because gas can escape from the main burner whilst the thermocouple is energised.

8.7 To turn off the air heater;

- a) For short periods;
- Adjust room thermostat to lowest setting or switch **OFF** other external controls;
- b) for extended periods;
- Follow a) above and then;
 - Turn **OFF** gas control valve figures 8 & 9;
 - Switch **OFF** electricity supply to the air heater after the air circulation fan has stopped.

Caution:

The gas service tap to the air heater must not be turned off except in emergencies or for appliance servicing purposes or for prolonged periods of shut down of the air heater.

Figure 9.
GAS CONTROL EURO-X 1000 A 1055 - 1095

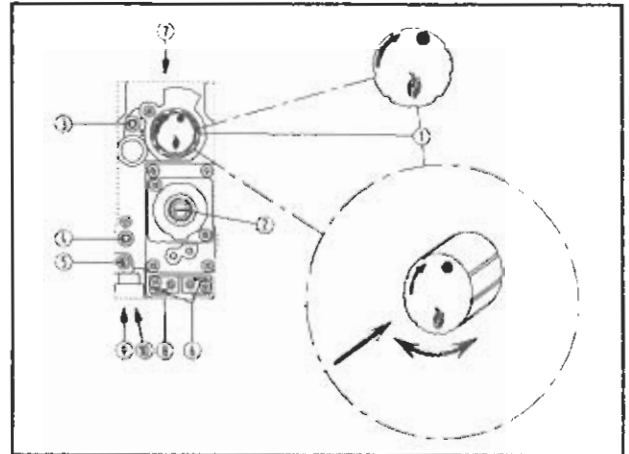

Legend figure 9.

1. Operating button
2. Gas governor
3. Inlet gas pressure test point
4. Outlet/burner gas pressure test point
5. Ignition burner gas throttle screw
6. Main burner electrical connection
7. Gas inlet connection
8. Gas outlet connection
9. Ignition burner gas connection
10. Thermocouple connection

8.8 LIGHTING AUTOMATIC IGNITION

EURO-X 1000 A models fitted with optional Hot Surface Ignition system.

- 8.8.1 Ensure that the air discharge louvres are set to an open position;
- 8.8.2 Switch **ON** the electricity supply to the air heater;
- 8.8.3 Turn **ON** the gas supply to the air heater;
- 8.8.4 These appliances employ the direct burner ignition principle. When the external controls call for heat, a hot surface igniter will be energised and will glow for ± 15 seconds, after which time the gas valve(s) will open and the burner will be lit.
- 8.8.5 If the burner has not lit within 5 seconds, the electronic flame relay will switch off and lockout will occur. This will cause the signal lamp to glow within the reset push-button on the appliance and/or on a remote control (if fitted). After 10 seconds the reset button on the appliance or the remote control can be activated in order to reset and restart the appliance.
- 8.8.6 Flame failure protection is by the ionisation principle i.e. the ability of a suitable flame to

pass an electrical current between the igniter and the earthed burner assembly. To check the flame current is adequate, remove jumper between terminal 17 and 18 on the automatic burner control, connect a DC micro ammeter between the terminals. Ionisation current should be $> 2\mu\text{A}$.

Note: The terminals carry mains voltage when energised.

8.9 How the EURO-X 1000 A air heater works

EURO-X 1000 A thermoelectric burner control air heaters operate automatically after the permanent ignition burner has been lit.

These appliances are fitted with a thermo-electric flame failure device. External controls (room thermostat - time switch) operate to provide heat on. Upon switching to on, the main burner gas valve opens and the main burner is lit automatically from the permanent ignition burner.

Models fitted with hot surface ignition systems operate fully automatically when switched **ON** and the remote controls have been set to call for heat.

Simultaneously to being switched **ON** an electrical circuit is made to a thermal fan control switch to operate a heater within the switch.

This plus the heat of the burner causes the switch contacts close. When hot, at approximately 45°C, the air circulation fan will switch on and warm air will be discharged until the burner is switched off.

Note :

1. The fan will run on after the burner has switched off to cool the heat exchanger.
2. During periods of extreme cold operating i.e. morning start up, the fan may switch on and off for short periods due to the rapid cooling of the thermal fan switch. This will cease as the ambient temperature around the air heater rises.

In the event of overheating for any reason, thermally activated, fail safe overheat controls operate to protect the air heater.

The first control LC1 switches off the burner and upon cooling will automatically reset.

The second control, LC3, which switches at a higher temperature will if activated switch off the main burner and on thermoelectric models the ignition burner, thus causing controlled lock-

out. Following this manual intervention is necessary to restart the air heater by relighting the ignition burner or resetting an automatic burner control after the air heater has cooled and the LC3 control has automatically reset or on automatic ignition models can be itself reset, this may take a few minutes dependent upon the ambient temperature.

8.10 Upon completion of the commissioning, ensure the user or a responsible person is aware of;

- a. How to operate air heater;
- b. The need for maintenance and servicing;

Important

Ensure that these instructions and the user's instructions are made available for the user and/or left in a safe place, i.e. attached to the gas service meter.

END OF COMMISSIONING INSTRUCTIONS

SECTION 9 SERVICING INSTRUCTIONS

9.1 CAUTION:

Inadvertent substitution or replacement of components similar to those specified or replacement in a manner contrary to the method herein described could constitute a hazard.

Servicing work must only be carried out by appropriately qualified persons.

9.2 Attention:

Before starting to service the air heater turn **OFF** the main gas supply to the heater at the service tap provided. Switch **OFF** the main electricity supply to the heater after the air circulation fan has stopped.

- 9.3 **EURO-X 1000 A** air heaters require maintenance and service at least once a year. More frequent servicing may be required dependent upon the environmental circumstances where the air heater(s) are installed. Advise the user of recommended service frequency after your findings during this service. Regular inspection is recommended initially, especially in dirty areas, to **assess the servicing requirement** frequency. Refer to the illustrations provided figs. 14 & 15 for component and visual instruction as a guide to carrying out service work. Items that require inspection during servicing are as described below.

FIGURE 10. BURNER ACCESS PANEL REMOVAL

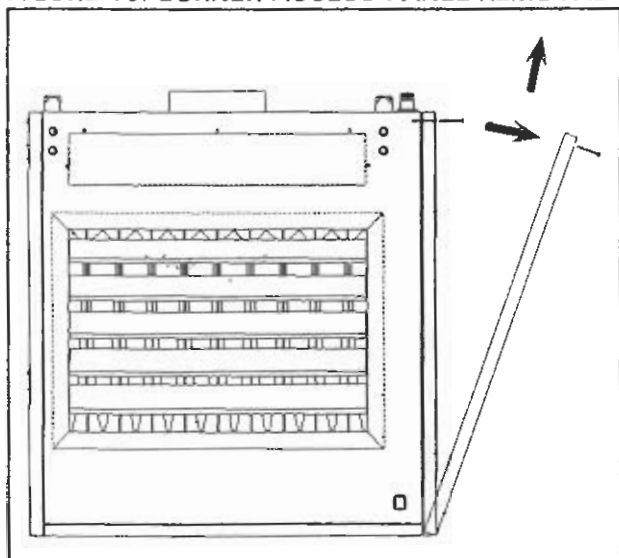

9.4 General :

Generally clean all accessible surfaces including the outside of the heat exchanger accessible after removal of the louvre frame and fan assembly.

9.5 Heater casing :

Check for damage that could be detrimental to the correct fitting of panels and affect the correct working or noise level. Check that all assembly screws are fastened, replace missing screws. Check that all panels are fixed in place upon completion of service and that motors, fans and guards are fixed securely.

9.6 Heat exchanger :

To be checked when carrying out burner and flue section work. Inspect heat exchanger where visible inside by use of an inspection lamp and mirror and outside when burner, air circulation fan and louvre frame have been removed.

Look for signs of severe corrosion, splits and perforations that would indicate a failure. If upon inspection it is found that the heat exchanger is excessively dirty or blocked with e.g. soot, it will be necessary to remove the front portion of the draught diverter to aid cleaning. This can be carried out referring to fig. 12.

1. Remove the screws securing the front of the down draught diverter Key 1 and the side screws
2. The portion of the down draught diverter may then be withdrawn through the front slot by lifting and pulling outwards.
3. To replace reverse above procedure

Remove any deposits with a flexible flue brush. Remove loosened deposits with a vacuum cleaner. IF HEAT EXCHANGER IS FOUND TO BE PERFORATED ADVISE USER NOT TO OPERATE HEATER UNTIL A REPLACEMENT HAS BEEN FITTED.

9.7 Burner :

The orifice of a gas injector is machined to precision limits, do not clean with a hard sharp object that could damage or enlarge the size. Remove burner tray carefully see below. Check main burner rails for soundness. Clean thoroughly taking particular care to ensure that burner ports are free from lint and dust.

Check gas injectors for cleanliness and that thread joints are gas tight. If necessary clean with acetone. Do not over-tighten.

**FIGURE 11.
BURNER ASSEMBLY REMOVAL**

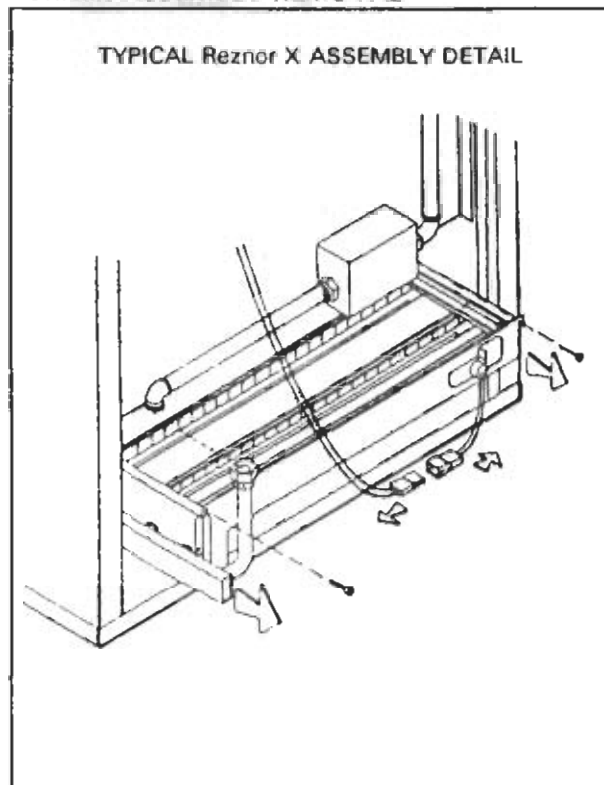

9.8 Burner tray removal :

Refer to figs. 11, 15 & 16

- 1 Disconnect gas supply at the unions below the inlet gas service tap and adjoining the gas control valve.
- 2 Disconnect the wires leading to the gas valve at the valve terminal end.
- 3 Disconnect wires leading to the thermal overheating cut off device terminals.
- 4 Unscrew qty. 2 burner tray fixing screws.
- 5 Withdraw the burner assembly by pulling from its runners until it is released.
- 6 To reassemble reverse procedure 1 thru. 5.

9.9 Note :

Appliances for use on propane or butane gas have an aeration shutter fitted to the burner inlet air venturi (see fig. 17). This device may also be fitted to natural gas appliances which have been converted. The shutter is set and sealed by a multi-functional sealing plate marked LPG + NG. Ensure it is correctly reset after any burner service work is carried out.

9.10 To renew or service the gas valves :

Remove burner rack assembly as described 9.7 above. To dismantle valve from manifold, take care when using spanners not to damage valve hodies which are constructed from soft die cast aluminium. It is necessary to remove the burner manifold from the burner ribbon tray assembly to

unscrew the gas valve.

**FIGURE 12.
DRAUGHT DIVERTER REMOVAL**

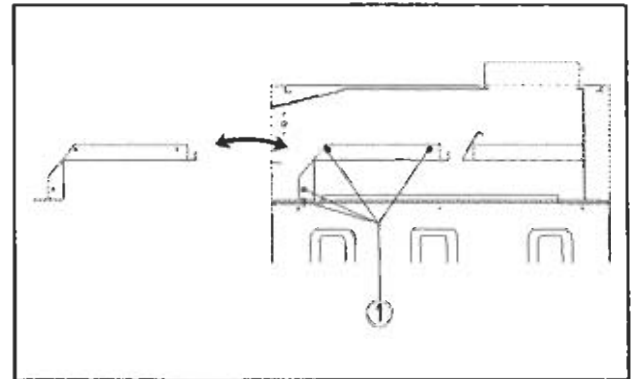

Legend figure 12:

1. Draught diverter securing screws left and right hand side.

9.11 Electrical:

Check all visible wiring for damage, check terminal security.

When removing for service or renewal any electrical component follow a logical sequence to ensure that replacement will be correct. Mark wiring to ensure before disconnection to ensure that circuits are re-connected correctly.

9.12 Flue system:

Check that flue is in good condition adequately supported and that the flue and supports are free from corrosion and that the flue is unobstructed. Test for a positive updraught when re-commissioning the appliance by using smoke introduced into the draught hood slot at the front of the air heater.

On flue systems fitted with a Reznor Euroventer refer to the separate instructions supplied with the Euroventer.

9.13 Fan assembly:

When it is necessary to remove the fan blade from the motor it should be noted that the securing screw is fitted using a thread sealing compound. local heat may be required to soften the compound so that the screw may be loosened.

Figure 13.
THERMOELECTRIC IGNITION BURNER DETAILS

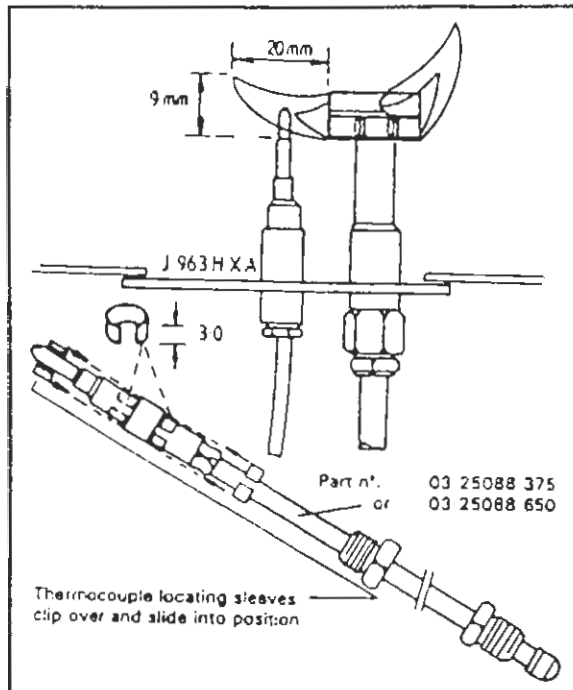
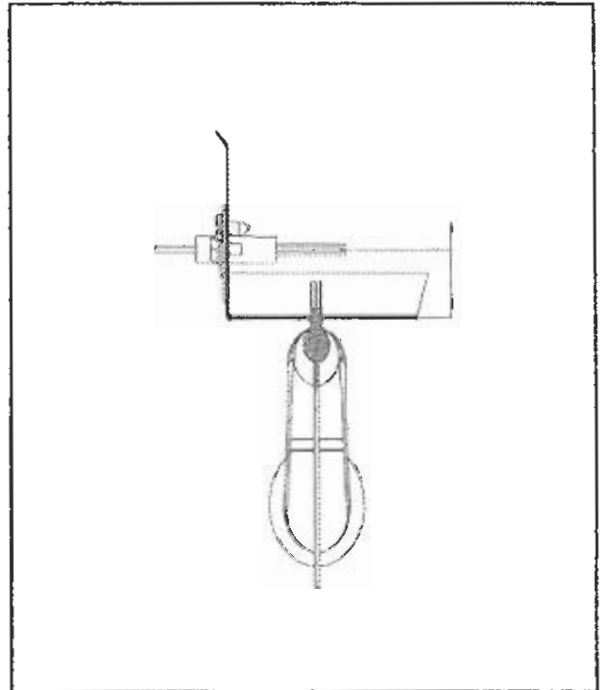

Figure 14.
HOT SURFACE IGNITER ASSEMBLY DETAILS



9.14 Figure 13 shows the approximate flame pattern of the ignition burner and its relationship to the flame proving thermocouple

NOTE: Location of the spacer rings when replacing a thermocouple. Ensure that pilot flame plays on thermocouple hot-tip only, i.e. top of thermocouple.

9.15 After any service work has been carried out re-commission the air heater following the steps outlined in clauses 8.2 and 8.3 of this document.

END of SERVICE INSTRUCTIONS

Figure 15. COMPONENT PARTS LOCATION THERMOELECTRIC BURNER CONTROLS

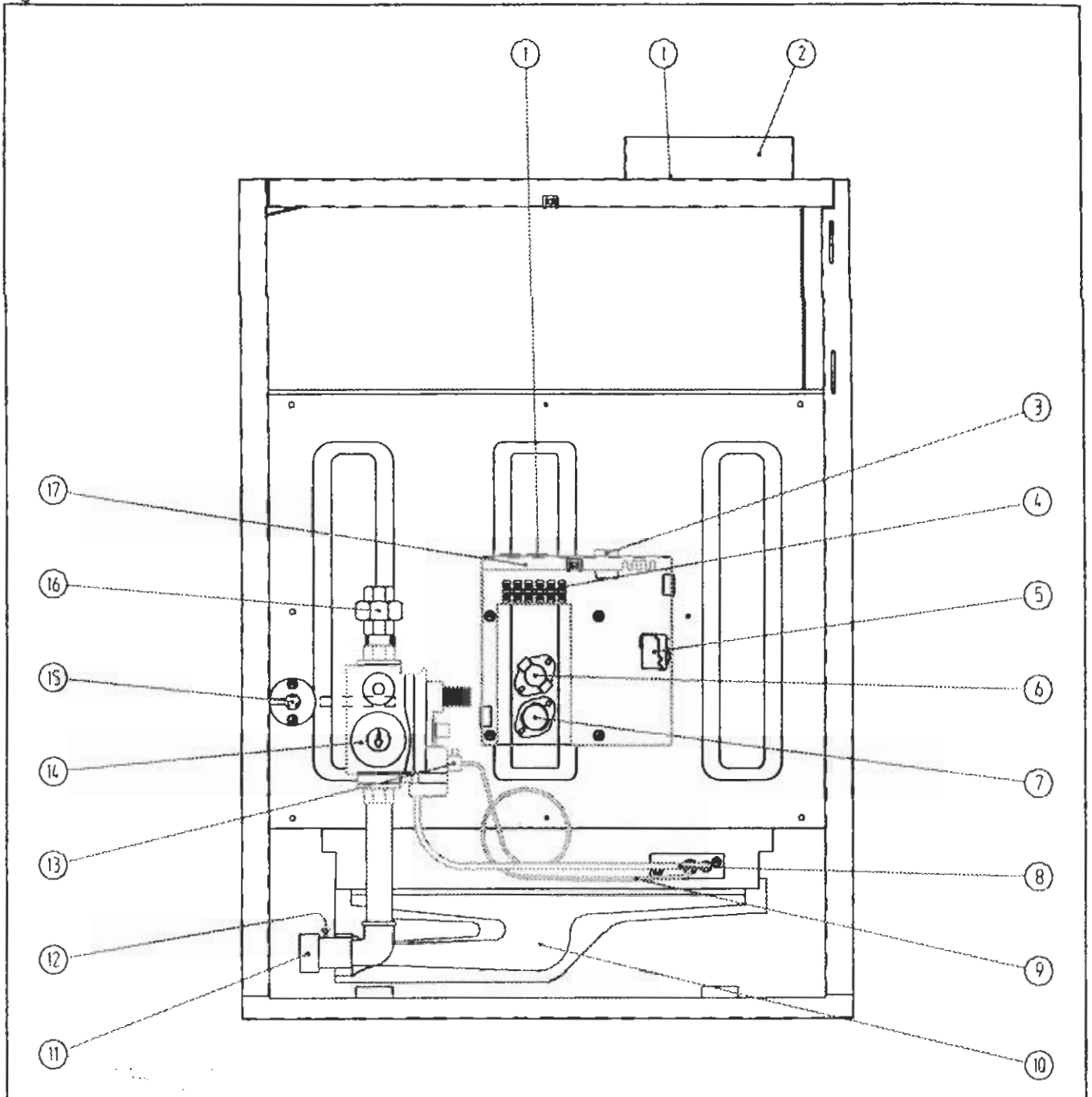

Legend figure 15:

- | | | | |
|----|-------------------------------------|-----|--|
| 1. | Electrical and Controls inlet | 10. | Burner ribbon |
| 2. | Flue socket | 11. | Burner manifold with gas jets |
| 3. | Controls fuse | 12. | Burner gas pressure test point |
| 4. | Wiring terminals | 13. | Thermocouple connection LC3 |
| 5. | Thermal overheat control LC3 | 14. | Multi-functional gas control |
| 6. | Limit control LC1 | 15. | Thermal overheat control LC3 sensor |
| 7. | Thermal fan control | 16. | Inlet gas connection union |
| 8. | Ignition burner | 17. | Main wiring box |
| 9. | Thermocouple | | |

Figure 16 COMPONENT PARTS LOCATION HOT SURFACE IGNITION BURNER CONTROLS

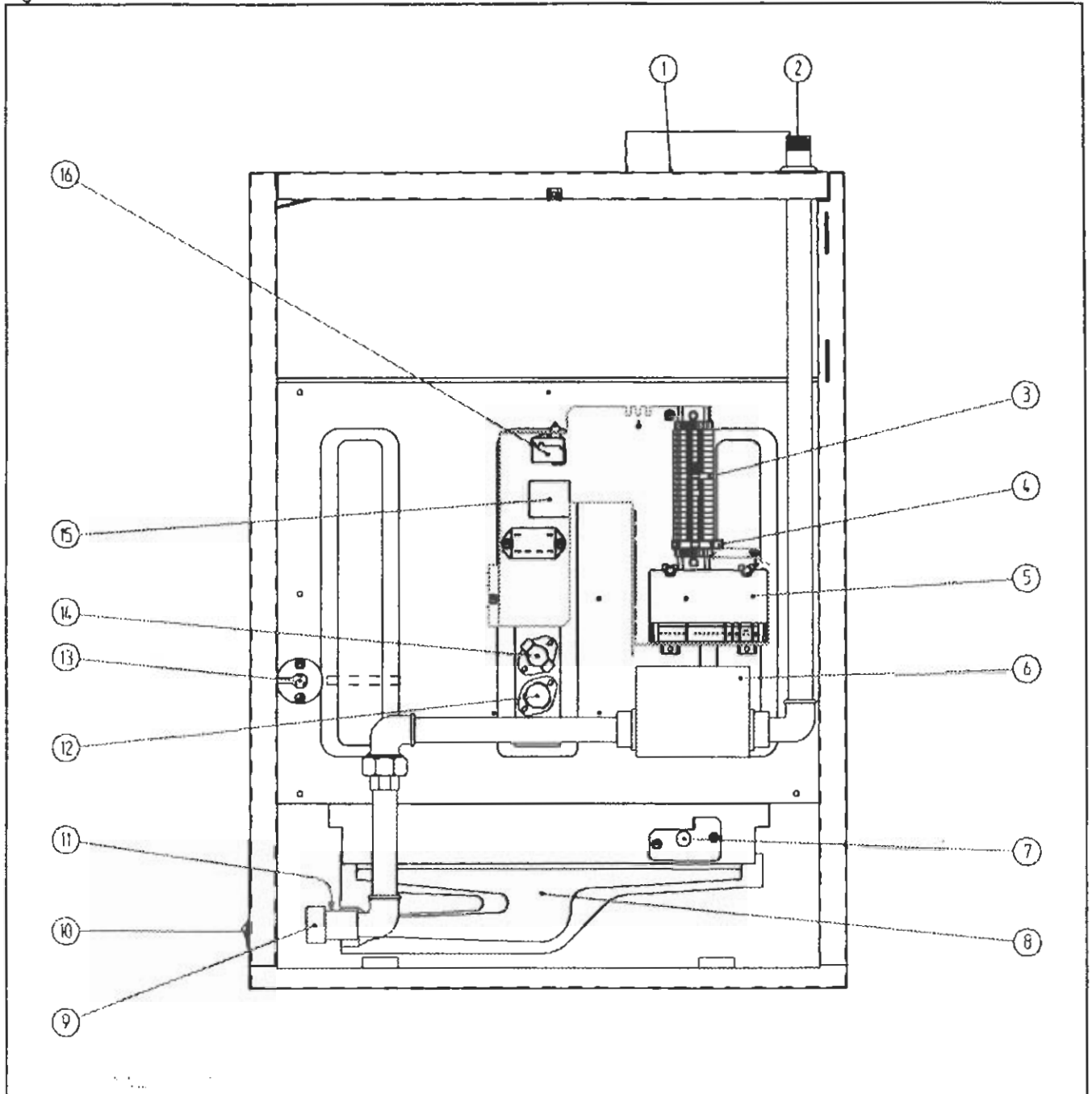

Legend figure 16

- | | | | |
|----|-------------------------------------|-----|--|
| 1. | Flue socket | 9. | Burner manifold |
| 2. | Gas inlet connection | 10. | Burner fail indicator |
| 3. | Main wiring terminals | 11. | Burner gas pressure test point |
| 4. | Controls fuse | 12. | Thermal fan control |
| 5. | Automatic electronic burner control | 13. | Thermal overheat control LC3 capillary |
| 6. | Gas valve | 14. | Thermal over heat (limit) control LC1 |
| 7. | Hot surface ignition | 15. | Not applicable for GB & IE |
| 8. | Burner ribbon | 16. | Thermal overheat control LC3 |

SECTION 10 SPARE PARTS LIST

NOTE: Components specific to either Thermoelectric burner control or Hot Surface Ignition are indicated thus:
TE = Thermoelectric burner controls HS = Hot Surface Ignition systems

10.1 GAS SECTION

DESCRIPTION	?	PART NUMBER	MFGS. REF.	APPLICATION
Gas valve	TE	03 25260	SIT 820 Nova ½"	1025 - 1045
Gas valve	TE	03 24980	H'well V 4600A ¾"	1055 - 1095
Gas valve	HS	03 25250	SIT 830 Tandem	1025 - 1045
Gas valve	HS	03 25136	H'well VR4601AB	1055 - 1095
Gas valve	HS	03 35136	H'well VR4601PB	All 2 stage
Ignition burner	TE	05 25164 J963HX	J 963 HXA	All
Gas jet Ignition burner	TE	07 25824 018	62/18	All models NG only
Gas jet Ignition burner	TE	07 25824 010	42/10	All models LPG only
Gas jet Main burner		07 25801 022	φ 2,2 mm	1035 NG
Gas jet Main burner		07 25801 024	φ 2,4 mm	1025, 1030 - 1045 1095 NG
Gas jet Main burner		07 25801 026	φ 2,6 mm	1095 NG
Gas jet Main burner		07 25801 125	φ 1,25 mm	1035 LPG
Gas jet Main burner		07 25801 130	φ 1,30	1030 LPG
Gas jet Main burner		07 25801 135	φ 1,35 mm	1025, 1045 - 1075 LPG
Gas jet Main burner		07 25801 140	φ 1,40 mm	1095 LPG
Thermocouple connector	TE	03 25261	SIT	1025 - 1045
Thermocouple connector	TE	03 25154 760	Honeywell	1055 - 1095
Thermocouple set	TE	35 25087	Bul. 18	All
Olive fitting Valve end	TE	07 25273H	M 6	ALL
Olive fitting Burner end	TE	07 25273B	M 6	ALL
Ignition gas supply tube	TE	07 25256 500	φ 6 mm x 500 mm	ALL

CODES: NG = Natural gas G20 LPG = Butane gas G30 or Propane gas G31

10.2 ELECTRICAL SECTION

DESCRIPTION	?	PART NUMBER	MFGS. REF.	APPLICATION
Thermal fan control		03 25166	TOD29T12 (250V)	All
Thermal overheat control LC1		03 24970	TOD60T11 51,5 °C	NOT 1055 & 1095
Thermal overheat control LC1		03 24969 01	TOD60T11 63 °C	1055 & 1095
Thermal overheat control LC3	TE	03 24962	limit 96 °C 5417LS3	All TE
Thermal overheat control LC3	HS	03 24959	limit 96 °C 5417LS1	All HS
Automatic burner control	HS	03 25317	H'Well. S4570LS	All HS
Hot surface ignitor assembly	HS	36 25217	Norton 240V	All HS
Fuse	All	06 00157 125 mA	125 mA quickblow	All
LC 3 Wire connector	TE	06 41624	H'Well.	All TE
Wire harness for burner control	HS	06 41531 HGC	All HS
Wire harness for ignitor	HS	06	All HS
Wiring terminals		06 41635	Enterlec	All
Gas valve connector plug	TE	03 24260 V1	SIT	All TE
Wire harness 2 stage burner control		06 41621	All HS

10.3 Air handling section

DESCRIPTION	PART NUMBER	MFGS. REF.	APPLICATION
Fan motor	01 26006 04	MAC35W4	1..25/26
Fan motor	01 26006 05	MAC50W4	1..30/31
Fan motor	01 26006 07	MXC60P6	1..35/36 & 1..45/46
Fan motor	01 26006 09	MXC70P6	1..55/56:
Fan motor	01 26006 12	MXC50L6	1..75/76
Fan motor	01 26006 16	MXC65L6	1..95/96
Axial fan	02 26008 04	S40/4PR23	1..25/26
Axial fan	02 26008 05	S40/4PR30	1..30/31
Axial fan	02 26008 07	S40/4PR17	1..35/36 & 1,45/46
Axial fan	02 26008 09	S60/3PR25	1..55/56
Axial fan	02 26008 12	S70/3PR17	1..75/76
Axial fan	02 26008 16	S70/4PR20	1..95/96

SECTION 11 CONVERSION DATA

11.1 Reznor EURO-X 1000 A air heaters are designed to operate on natural, propane or butane gas and will be supplied fitted for the gas type ordered.

In the event of site conversion to a different gas type it is necessary to convert the gas burner and burner controls.

To carry out the conversion refer to section 9 of this document which explains how to remove and replace the burner assembly.

11.2 The following changes must be made:

- a. Change the main burner jets to the size as given in 10.1;
- b. Change the ignition burner jet as given in 10.1;

c. Set burner primary air shutter as appropriate referring to figure 17;

e. Adjust gas governor;
Natural gas to setting pressure as per data plate supplied;

LPG gases to maximum pressure setting adjuster screwed in to stop. Seal governor after setting.

For LPG gases a governor blank off plate may be used, remove governor and fix plate;

f. Affix new data plate and gas type over-sticker

11.3 Upon completion of conversion re-commission the air heater in accordance with section 8 of this document.

Figure 17. GAS CONVERSION DATA

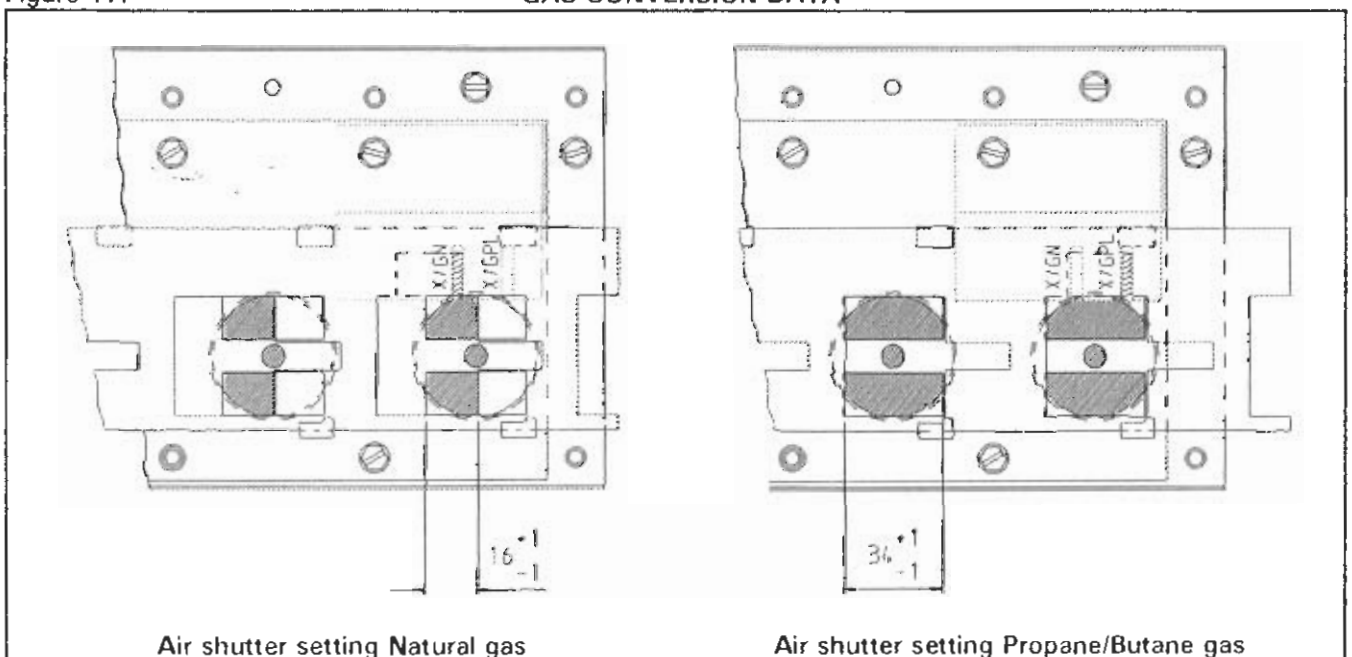

SECTION 12 FAULT FINDING

THERMOELECTRIC BURNER CONTROL MODELS

12.1 Ignition burner will not light :

- Read lighting instructions;
- Check gas supply is turned on;
- Air in gas supply : check purging;
- Excessive high/low gas pressure : adjust throttle screw figs. 8 & 9;
- Blocked ignition burner injector orifice
- Faulty gas valve : renew;

12.2 Ignition burner lights but will not establish

- Loose connection on thermocouple or reroute leads : check security;
- Ignition burner flame too small : adjust;
- Ignition burner jet dirty : clean;
- Thermal overheat (limit) control LC3 loose connection on control terminals: check renew connection as necessary, loose connection on gas valve;
- Faulty thermocouple : renew;
- Faulty gas valve : renew;
- Faulty overheat (limit) control LC1 or LC3: renew;

12.3 Ignition burner lights and established but main burner will not light :

- Check electricity supply switched ON;
- Check room thermostat is calling for heat : adjust;
- Check time switch if fitted is in ON mode;
- Open circuit to gas valve : check wiring;
- Faulty gas valve : renew;
- If appliance is fitted with a Euroventer : check it is operating.

12.4 Main burner lights and goes out after short period :

- Insufficient combustion air : open door or window to check air supply;
- Euroventer air flow proving operating when flue gas is hot : check flue and Euroventer air proving system;
- Room thermostat in warm air flow : check temperature around thermostat;
- Room thermostat on vibrating surface : check contacts chattering near set points;
- Fan rotating slowly, heater operating on thermal limit control LC1: check fan motor, suspect capacitor fault;
- Fan guard blocked with dust to reduce air flow : clean;
- Discharge louvres closed : open;
- Ambient air temperature too high, set point reached.

HOT SURFACE IGNITION CONTROL MODELS

12.5 Burner does not light:

- Thermostat set too low;
- Controls fuse has blown;
- If fitted Euroventer not operating;
- Burner relay in lock-out or faulty;
- Faulty thermal over heat (limit) control;
- Thermal over heat control LC3 in lock-out mode;
- Faulty hot surface igniter;
- Insufficient ionisation flame current : should be $> 2\mu\text{A}$;
- Incorrect wiring or bad earth connection.

12.6 Cool air is discharged continuously at start up or during operation when burner is off? :

- Room thermostat on : set to off;
- Ignition burner is unlit : light up;
- Thermal fan switch faulty : renew switch;
- If fitted manual override fan switch in ON mode : switch OFF;

12.7 Air circulation fan will not run :

- Open circuit : check;
- Thermal fan control switch faulty : renew;
- Defective fan motor capacitor : renew;
- Defective motor : renew;

12.8 Air circulation fan runs and stops while burner remains alight :

- Thermal fan switch heat element broken : renew switch;
- Low ambient temperature : wait, it will correct as temperature rises;
- Motor thermal overload switch operating : check motor current rating - renew motor if faulty;
- Thermal fan control heater element wiring incorrect : check, correct if necessary;
- Faulty thermal fan control : renew;

SECTION 13 HEALTH AND SAFETY STATEMENT

Health and Safety Information for the Installer and Commissioning-Service Engineer

Under the Consumer Protection Act 1987 and Section 6 of the Health and Safety at Work Act 1974 we hereby provide the following information on substances hazardous to health. Product range reference: "EURO-X 1000 A"

13.1 During first firing some smoking may occur, this is due to the burning off of protective/lubricating oils used during appliance production. Most of this will have been removed during the production testing process. It is a wise precaution to ensure that adequate ventilation is provided during the initial firing and throughout the commissioning period, this is particularly important if the discharge air is to blow into a confined space. This smoking does not constitute a poison hazard.

13.2 Reznor products contain no asbestos; copper is not employed in gas carrying components; solder which has a melting point below 450°C is not used; paints for corrosion protection and decoration are heat cured and contain no lead.

13.3 The above appliances meet the Electrical Safety requirements of EN60 335 Pt 1 1988.

13.4 Small quantities of adhesives and sealants used in the product are dried and cured and present no known hazard.

13.5 Insulation and Seals.

Material: Synthetic Ceramic Fibre with Organic binder.

Description: Tapes and Papers

Known hazards: Some people can suffer reddening and itching of the skin. Fibre entry into the eyes will cause foreign body irritation. Inhalation will cause irritation to the respiratory tract. As with any dust pre-existing respiratory condition and lung diseases may be aggravated.

Prolonged exposure for the purposes envisaged pertaining to this Reznor product is not anticipated.

Precautions: Wear protective gloves when handling. If abrading and dust is generated suitable protective respirators must be used.

People with a history of skin complaints may be susceptible to irritation.

Dust levels are only likely when the material is abraded.

In general normal handling and use for this purpose will not present discomfort. Follow good hygiene practices, wash hands before consuming food or using the toilet.

First Aid: Medical attention must be sought

following eye contact or prolonged reddening of the skin.

13.6 Thermostat.

Material: Illuminating Kerosene.

Description: Sealed phial contains a small quantity in liquid form.

Recognition: Colourless liquid, paraffin oil/petroleum hydrocarbon odour.

Characteristics: Non-corrosive, flammable with no poisonous reference - CH poison Class 3

Precautions: Avoid handling. This product can irritate and defat the skin. Prolonged contact may cause dermatitis. Avoid breathing vapour. Avoid eye contact. Do not ingest.

First Aid: Skin. Wash thoroughly with soap and water.

Eyes. Rinse immediately with copious amounts of clean water.

Ingestion: Seek medical advice.

NOTE: If skin irritation persists seek medical advice.

13.7 Electrolytic Capacitor

Two types are used by random selection:

Recognition:

1. Plastic enclosure 2. Aluminium enclosure

Material: Contained liquid electrolyte

Known hazards: Electric shock possible if charged.

Precautions: Discharge to ground/earth. Do not incinerate.

First Aid: Treat for electric shock if affected.

END OF HEALTH AND SAFETY STATEMENT

Reznor 08/01

SECTION 14 USER INSTRUCTIONS

NOTE: Keep a copy of this document near your air heater !

WARNING: This appliance must be earthed.

- 14.1 Your Reznor EURO-X 1000 A air heater should have been installed, commissioned and tested in accordance with these the manufacturer's written recommendations.
- 14.2 In the interest of safety and user satisfaction it is important that this document is read and understood. If in any doubt, consult your installer or your local gas region supplier.
- 14.3 It is in your interest to ensure proper service and maintenance is carried out on a regular basis by a competent service undertaking. Reznor suggests at least once every year.
- 14.4 In the event of difficulties in resolving any of these matters, please do not hesitate to contact the manufacturer or their official distributor.
- 14.5 **About your air heater :**

- EURO-X 1000 A air heaters are state of the art gas fired appliances and incorporate an atmospheric burner which uses air for combustion taken from the location in which the air heater is installed. Products of combustion are vented to outdoor atmosphere via a permanently connected natural draught flue. The flue system may incorporate a fan to assist evacuation of the flue gasses.
- These heaters have not been designed for use with air distribution ducting. Through the wall straight stub ducts are allowed up to a maximum of 1.0 m long.
- The location of the air heater should be maintained at normal ambient pressure. Changes to the building after air heater installation should have regard to the heating installation, i.e. creation of draughts from doors, windows. Other air handlers and installation of air extraction equipment may cause equipment may cause negative pressure environments, which can, seriously affect the operation of this type of air heater.
- The space heating process using Reznor EURO-X 1000 A air heaters is for air to be circulated through the appliance whereby it gains heat from a heat exchanger which is directly discharged into the space to be heated. The air is eventually re-circulated through the appliance thus an unobstructed path for the return air must be maintained. This is particularly important when installed to blow through the wall between two rooms.

14.6 How the air heater works :

Gas is burned by an atmospheric burner which fires into a multiplex combined combustion/heat exchanger. The gas burner is controlled by a gas valve which is switched via external controls i.e. a room thermostat and time switch.

EURO-X 1000 A air heaters are available with a choice of burner ignition systems;

Thermoelectric: Incorporate a permanent pilot flame on a separate ignition burner which requires manual lighting as described below, or;

Automatic Hot Surface Ignition System: Which operates automatically at the dictates of the external time and temperature controls.

Air heaters with a permanent flame ignition are protected by a thermo-electric flame failure device. Once the ignition burner has been lit and established the heater operation is automatic following the dictates of the external timing and/or temperature controls.

Air heaters with hot surface ignition are protected against flame failure by the igniter acting as a sensor in the burner flame. When the external controls signal a call for heat the igniter becomes energised and after a short time it glows, when sufficient heat to light the gas has been generated, then the gas valve/s open and the burner lights.

Safety against overheating is assured by the inclusion in the controls circuit of two thermal overheat controls. There is an automatic recycle control which protects against low air flows i.e. clogged air ways, fan failure ! The second control being a super overheat control which operates to switch off the ignition burner in the event of gross overheating for any reason. Two types of this control are employed for this function to suit availability, they can be identified by looking into the controls compartment of the air heater and comparing with figures 15 or 16. Manual intervention to relight the ignition burner is necessary for thermoelectric appliances, manual intervention to reset the electronic burner control either on the appliance or a remote control device is necessary on those fitted with hot surface ignition systems.

When the main burner fires and warms the heat exchanger, the heat is sensed by a thermally actuated fan control which switches on the fan when the temperature has reached approximately 45°C. At the end of a heating cycle when the burner is switched off, the air circulation fan will

continue to run on until the air heater has cooled to a safe condition. Thereafter the fan will remain off until the next cycle is initiated.

FIG 18 USER LIGHTING ACCESS PANEL

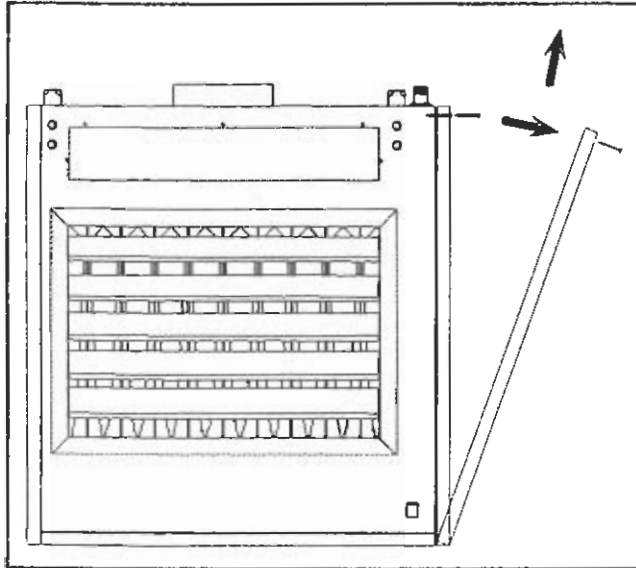

14.7 To light the air heater:

Thermoelectric;

Models EURO-X 1000 A
1025 - 1045 see fig. 19

Carry out the following procedure (which is also displayed on the air heater casing)

- Ensure that the air discharge louvres are set to an open position;
- Turn **ON** the gas supply to the air heater;
- Switch **ON** the electricity supply to the air heater;
- Set room thermostat or remote control to an **OFF setting**;
- If fitted ensure that a time control is at an **ON setting**;
- Observe gas control details from figures 19 & 20 set control to star position:

Using a lighted taper or match depress and hold the control valve start knob and apply light to the ignition burner. When the ignition burner has lit, hold control for 30 seconds. Ignition burner should remain alight when released. Turn knob to "Flame" position

NOTE:

If ignition burner has not lit wait five minutes and repeat the lighting procedure

- Having established the ignition burner set control to "Flame" position, appliance operation is now fully automatic;

- Set room thermostat to call for heat and/or adjust to the desired comfort level. The pilot burner will now light the main burner.
- In the event that the pilot flame goes out for any reason it is important to wait five minutes before attempting to relight the gas due to the possibility of main gas flowing from the main burner if the thermocouple has been energised.
- To stop the burner, put the control knob to the **OFF** position as indicated figure 18. It must be noted there is a security interlock which prevents relighting for one minute.

14.8 To light the air heater:

Thermoelectric burner control

Models EURO-X 1000 A
1055 - 1095 see fig. 20

Carry out the following procedure (which is also displayed on the air heater casing)

- Switch **OFF** electricity supply to the air heater;
- Ensure that the gas supply to the air heater is on;
- Set room thermostat to **OFF** or its lowest setting. If fitted, ensure time switch is set to an **ON** cycle;
- Depress and hold control valve start button fig. 20;
- Using a lighted taper or match light the ignition burner located as shown;
- Keep start button depressed 20 seconds after ignition burner has lit;
- Close burner compartment access door;
- Switch **ON** electricity supply to the air heater;
- Adjust room thermostat to desired temperature and any other external controls to on;

Important :

If ignition burner pilot flame fails to light or goes out for any reason allow 3 minutes before re-lighting. This time must also be allowed before a re-ignition attempt if there is a flame failure of the main burner for any reason.

To turn off the air heater for short periods

- Adjust room thermostat to lowest setting or switch to off other external controls; To turn off for prolonged periods, carry out 'a' above then;
- Turn off gas control valve fig 19 or 20;
- Switch off main electricity supply after air circulation fan has stopped.

To turn off for prolonged periods, follow procedure outlined above & then turn off the gas inlet service tap.

- a Turn on the gas supply to the air heater;
- b Switch on the electricity supply to the air heater;
- c Ensure that time switch (if fitted) is set to an **ON** cycle;
- d Adjust room comfort control/ thermostat to desired temperature;
- e Air heater will now light automatically when the room thermostat calls for heat.
- f If the appliance does not light:

a) check the automatic burner control does not require resetting. An indicator light will glow on the front panel of the appliance or on a remote control where applicable. Reset by press the light button on the appliance or remote control.

b) check if the thermal over heat control requires resetting see figure 15 page 17 key 10;

If the thermal overheat control requires resetting and doing so **restarts** the air heater, wait until the appliance **warms** up to thermal equilibrium, to ensure that the over heat control does not operate again. **If it does and the temperature surrounding the air heater is less than 30 °C then switch OFF the appliance and call for service.** If the temperature surrounding the appliance exceeds 30 °C, take appropriate action to reduce the temperature in the vicinity of the appliance.

Warning:

The externally fitted gas service tap must not be operated except in emergencies or for servicing or prolonged periods of shutdown of the air heater.

Figure 19. LIGHTING THERMOELECTRIC MODELS X1025 · X1045

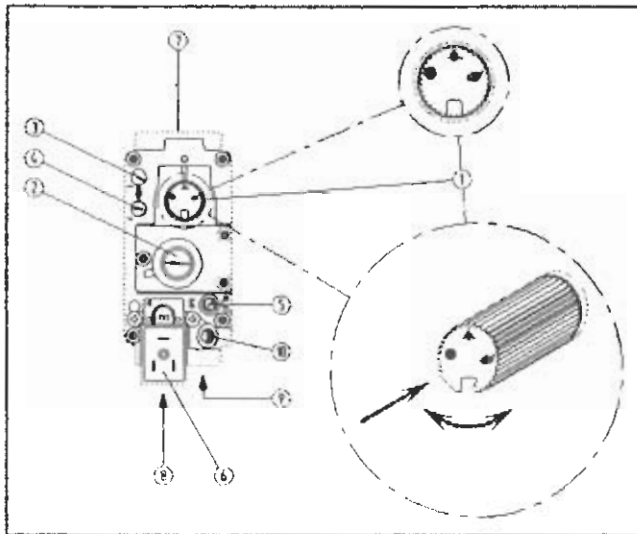

Legend figure 19:

- 1 Control knob
- 2 Governor
- 3 Inlet gas pressure test point
- 4 Burner pressure test point
- 5 Pilot gas throttle screw
- 6 Main burner electrical connection
- 7 Gas inlet
- 8 Gas outlet
- 9 Pilot gas line connection
- 10 Thermocouple connection

Figure 20. LIGHTING THERMOELECTRIC MODELS X1055 · X1095

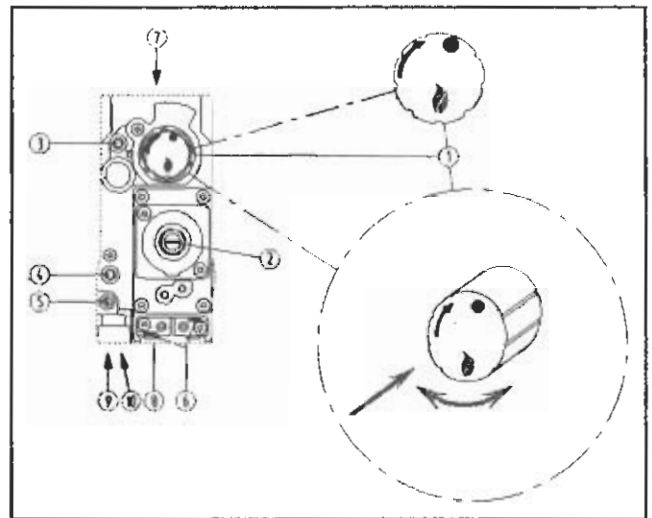

Legend figure 20.

1. Operating button
2. Gas governor
3. Inlet gas pressure test point
4. Outlet/burner gas pressure test point
5. Ignition burner gas throttle screw
6. Main burner electrical connection
7. Gas inlet connection
8. Gas outlet connection
9. Ignition burner gas connection
10. Thermocouple connection

14.9 Air circulation:

Some Reznor unit air heaters have fans connected to a remote override switch. This enables cool air to be used for circulation purposes when the air heater is not used for heating purposes e.g. in summer months.

- a. Switch ON mains electricity supply to the air heater;
- b. Switch ON the manual override switch on remote control panel;

14.10 Important:

In the event that the thermal overheat (limit) control LC3 has operated requiring relighting the air heater, wait close by the air heater for 15 minutes after relighting to ensure normal operation. If the overheat control locks out again, turn OFF the air heater and call for service to establish the reason and rectify the fault.

14.11 Euroventer:

Installations may include a Reznor Euroventer. This device is an electrically powered fan fitted into the flue system. Its inclusion will be obvious when a Euroventer is fitted the control switching of the air heater as described in 9.6 above is via the Euroventer, which is operationally proven prior to the burner control being activated.

14.12 Maintenance & servicing:

Maintenance and service must only be carried out by competent persons. Periods between service are dependent upon the local environment where the air heater is installed. Regular inspection is recommended initially to ascertain routine service intervals. Where local environmental circumstance change e.g. different processes being carried out in a factory, the service interval should be reconsidered. Ask your installer, service undertaking or the manufacturer about inspection and service intervals.

The service engineer is asked in section 9 of this document to advise the user of his recommended frequency for servicing after carrying out the first service.

The air heater should be serviced at least once every heating season. Ensure that any combustion air vents fitted to the building in which the air heater is installed are unblocked. Periodically check to ensure that the outer casing of the air heater is clean, excessive dust might constitute a hazard.

END OF USER INSTRUCTIONS

Reznor® EURO-X 1000 A

One of the 1st generation of CE marked gas fired energy efficient air heaters

Best used with Reznor optional electronic control panels save energy and optimise thermal comfort

Reznor Europe N.V.
J&M Sabbestraat 130
B8930 Menen
Belgium
Tel:+32(0)56 52 95 11
Fax:+32(0)56 52 95 33
e-mail:reznor_europe@tnb.com

Reznor UK Limited
Park Farm road
Folkestone
Kent
CT19 5DR
Tel: + 44 (0)303 259141
Fax: + 44 (0)303 850002
e-mail: sales@reznor.co.uk

Thomas & Betts