

TRIANCO



FLOOR STANDING
OIL FIRED CENTRAL HEATING BOILERS
FOR EXTERNAL INSTALLATION ONLY



TRIANCO

CE BED 92/42 EEC
EMC 89/336 EEC

**USER, INSTALLATION
COMMISSIONING & SERVICING
INSTRUCTIONS**

**FS External Models
EuroStar 50-90
EuroStar 95-115**

To be retained by householder

HEALTH AND SAFETY

INFORMATION FOR THE INSTALLER AND SERVICE ENGINEERS

Under the Consumer Protection Act 1987 and the Health and Safety at Work Act 1974, it is a requirement to provide information on substances hazardous to health (COSHH Regulations 1988).

The Company takes every reasonable care to ensure that these products are designed and constructed to meet these general safety requirements, when properly used and installed.

To fulfil this requirement products are comprehensively tested and examined before despatch.

This appliance may contain some of the items below.

When working on the appliance it is the Users/Engineers responsibility to ensure that any necessary personal protective clothing or equipment is worn appropriate to parts that could be considered as being hazardous to health and safety.

INSULATION AND SEALS

Glass Rope, Mineral Wool, Insulation Pads, Ceramic Fibre, Glass Insulation.

May be harmful if inhaled. May be irritating to the skin, eyes, nose or throat. When handling avoid inhalation and contact with eyes. Use (disposable) gloves, face masks and eye protection.

After handling wash hands and other exposed parts. When disposing, reduce dust with water spray, ensure parts are securely wrapped.

GLUES, SEALANTS & PAINT

Glues, Sealants and Paints are used in the product and present no known hazards when used in the manner for which they are intended.

KEROSENE & GAS OIL FUELS (MINERAL OILS)

1. The effect of mineral oils on the skin vary according to the duration of exposure.
2. The lighter fractions also remove the protective grease normally present on the surface of the skin rendering the skin dry, liable to crack and more prone to damage caused by cuts and abrasions.
3. Skin rashes (oil acne). Seek immediate medical attention for any rash, wart or sore developing on any part of the body, particularly the scrotum.
4. Avoid as far as possible any skin contact with mineral oil or with clothing contaminated with mineral oil.
5. Never breathe any mineral oil vapours. Do not fire the Burner in the open i.e. out of the Boiler as a misfire will cause unburnt oil vapours.
6. Barrier cream containing lanolin such as Rosalex Antisol, is highly recommended together with a strict routine of personal cleaning.
7. Under no circumstances should mineral oils be taken internally.

CONTENTS

	PAGE
1. USER INSTRUCTIONS	1/2
After sales service information	3
2. INTRODUCTION	4
3. TECHNICAL INFORMATION	5
Outline Dimensions	5
Technical specifications	6
External model wiring diagram	7
4. INSTALLATION	8
Regulations	8
Health and Safety	8
Siting the Boiler	8
Heating and domestic hot water system	8
Electrical supply	9
Thermostats	9
Frost Protection	9
5. OIL SUPPLY	10
Oil storage tank - Steel and Plastic	10
Oil supply line	10
Single pipe oil supply	10/11
Two pipe oil supply	10/11
Oil De-aerator - Single pipe supply	10/12
6. FLUE SYSTEM	13
Terminal Assembly	14
7. COMMISSIONING	15
Procedure	15
Handing over	15
8. SERVICING	15
Oil Tanks	15
Line Filters	15
Burner	15
Boiler	16
9. FAULT FINDING	17/18
10. SPARES	19
Boiler parts	19

HOW TO USE YOUR TRIANCO BOILER

The Trianco EuroStar has been designed and constructed to give years of trouble free service and these instructions are provided to assist you in obtaining the best performance with the least trouble and cost.

The boiler is fully automatic in operation and requires little attention other than the setting of the thermostat and any system controls such as a room thermostat and time-switch.

TO FIRE THE BOILER

Before firing the boiler, ensure the system is full of water, there is sufficient oil in the storage tank and all valves are open.

1. Check that the Time-switch/Programmer (if fitted) is ON and the room thermostat is calling for heat.
2. Set the boiler thermostat to the desired temperature.
3. Switch on the electrical supply to the boiler and the burner should fire after a few seconds of fan pre-purge.
4. Set the Time-switch/Programmer (if fitted) to the times and programme required.
5. The boiler will now operate automatically, cutting in and out according to the heat demand.

TO STOP THE BURNER

The burner may be stopped by turning the Boiler Control Thermostat fully anti-clockwise to the OFF position 'O'

If the boiler is to be off for a long time, it is recommended that the mains supply to the boiler is switched off or the Time-switch/Programmer (if fitted) is switched to the OFF position.

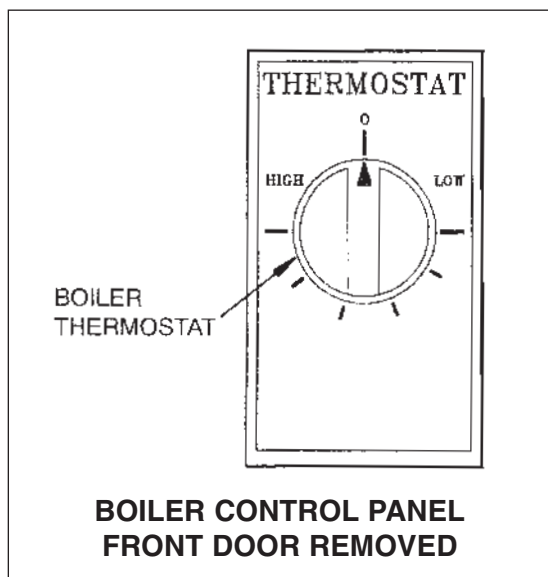

BOILER CONTROL THERMOSTAT

The boiler control thermostat enables you to select the temperature of the water leaving the boiler. It is calibrated between High and Low in five intermediate settings, corresponding to a temperature range of 82°C (high) to 55°C (low).

Set the temperature by turning the knob to the required temperature, however, the installer should take into consideration that the return water temperature **must not** drop below 60°C when the appliance is up to full operating temperature.

The thermostat is switched off when the knob is turned fully anti-clockwise with the pointer opposite 'O'.

HIGH LIMIT THERMOSTAT (Hand Reset)

The high limit thermostat is factory set and requires no adjustment. Should the boiler thermostat malfunction, the limit thermostat will take over and shut down the boiler.

If the limit thermostat operates frequently, consult your Service Engineer as there may be a fault in the system.

To reset the limit thermostat, remove the front panel and push in button.

Note: The limit thermostat can only be reset when the water temperature has dropped at least 20° C.

BURNER LOCK-OUT

If the burner fails to light, it will go to lock-out. If this occurs, wait about one minute then remove the front panel and press illuminated reset button to start burner. In the event of the burner not firing wait a further minute and then press the reset button again. If the burner still fails to start, switch off the electrical supply to the boiler.

WARNING - DO NOT ATTEMPT TO START BURNER MORE THAN TWICE

(See Simple Fault Finding before contacting your Service Engineer).

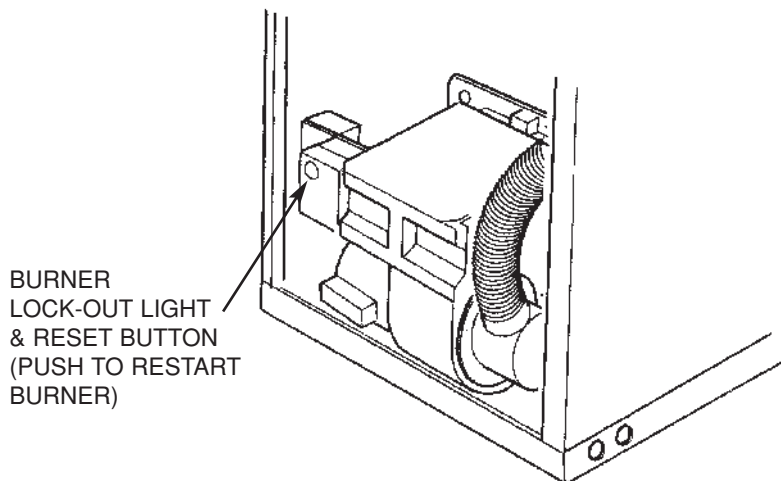

SYSTEMS CONTROLS

ROOM THERMOSTAT

The room thermostat should not be positioned near a source of heat such as a radiator or exposed to the sun as this will cause the central heating to switch off before the room is up to temperature. Follow the manufacturer's instructions for best siting position for the thermostat.

TIME-SWITCH/PROGRAMMER

When choosing the operating times for your boiler, it is useful to remember that central heating usually takes between half an hour to an hour before it becomes effective.

It is suggested that the Time-Switch/Programmer is set to bring on the heating about an hour before heating is required.

It is also worth noting that the heating system will usually remain effective for up to half an hour after boiler shut down. The timer can therefore be switched off earlier as an economy measure.

FROST PROTECTION

If the boiler and central heating is shut down for many hours during very cold weather, the water may be in danger of freezing and, as such, it is advisable to protect the installation with a frost thermostat.

If the system is shut down for a long period during very cold weather, it is advisable to completely drain the system. However, frequent draining should be avoided, especially in hard water areas, as this could lead scaling of the boiler waterways.

SHUTTING DOWN FOR THE SUMMER

If the boiler is shut down for the summer months, it is advisable to have it serviced and thoroughly cleaned as soon as possible to minimise corrosion of the heating surfaces.

OIL

The only fuel to be used with this appliance is 28 sec. Kerosene (BS 2869:1983 Class C2).

OIL TANK

Always ensure the tank is topped up at regular intervals, do not wait until the tank is nearly empty before refilling, otherwise sludge and water could be sucked into the oil pipe to affect the burner's operation and reduce pump life.

After a delivery of oil, it is recommended that the oil is allowed to settle in the tank for about half an hour before restarting the burner.

Sludge and water caused by condensation should be drawn off at the tank drain-cock annually.

SIMPLE FAULT FINDING

If the burner fails to start for no apparent reason, make the following checks before calling your Service Engineer.

1. Check for failure in the electrical supply e.g. a power cut
2. Check for a blown fuse. If the fuse has blown and on replacement blows again, switch off the mains electrical supply to the boiler and call your Service Engineer.
3. Check that there is adequate oil in the tank and the shut-off valves are open.
4. Check for burner lock-out. Press the reset button and burner should fire. **DO NOT PRESS MORE THAN TWICE.** Refer to 'Burner lock-out' for further advice.
5. Check for excess water temperature (Refer to 'High Limit Thermostat' for advice).

Note: If the boiler has been off as a result of a power failure, it will be necessary to reset the Time Switch/Programmer to the correct time unless it has a built-in power reserve.

SERVICING

To ensure efficient and reliable operation of the boiler, it is essential that the oil burner is initially commissioned by an OFTEC trained and registered engineer and an annual service is given thereafter.

Notes:

ELECTRICAL SAFETY CHECKS SHOULD BE CARRIED OUT BY A QUALIFIED ELECTRICAL ENGINEER

- (a) It is the responsibility of the Installer to ensure proper commissioning is carried out.
- (b) It is a requirement of the boiler's guarantee and any extended warranty that an annual service is carried out by a qualified engineer.

Commissioning Engineer's
Signature.....

Company Name.....

Address.....

Tel. No:.....

TRIANCO

CUSTOMER AFTER SALES SERVICE INFORMATION

A step by step guide to reporting a fault with your appliance

A qualified field SERVICE ENGINEER is available to attend a breakdown or manufacturing fault occurring whilst the appliance is under guarantee.

The appliance must be made available for service during normal working hours, Monday to Friday (no weekend work is accepted).

A charge will be made where:

- Our Field Service Engineer finds no fault with the appliance
or
- The cause of a breakdown is due to other parts of the plumbing/heating system (including oil line/lack of oil), or with equipment not supplied by Trianco.
or
- Where the appliance falls outside the guarantee period (see terms and conditions enclosed).
or
- The appliance has not been correctly installed, commissioned or serviced as recommended (see commissioning, installation and servicing instructions)
or
- The breakdown occurs immediately following an annual service visit. In this instance your appointed Service Agent must check all his work PRIOR to requesting Trianco to attend.

NOTE: Burner nozzles are currently guaranteed until the first service.

Over 50% of all service calls made are found to have no appliance fault.

What to do in the event of an appliance fault or breakdown:

Step 1: Always contact your installer or commissioning engineer in the first instance, who must thoroughly check all his work PRIOR to requesting a service visit from Trianco.

Step 2: If your appliance has developed an in-guarantee fault your installer should contact Trianco Service Centre for assistance.

What happens if my installer/engineer is unavailable?

Step 3: Contact Trianco Direct. We will provide you with the name and telephone number of our Service Agent. However, a charge may apply if the fault is not covered by the appliance guarantee (payment will be requested on site by our independent Service Agent).

PLEASE NOTE:

Unauthorised invoices for attendance and repair work carried out on this appliance by any third party will not be accepted by Trianco.

SERVICE CENTRE AND TECHNICAL SUPPORT

Tel: 0114 257 2300 Fax: 0114 257 2338

Hours of business Monday to Thursday 8.30am - 4.45pm

Friday 8.30am - 2.30pm

2. INTRODUCTION

The Trianco EuroStar Floorstanding external Boiler has been designed to conform to European Directive/Standards BED 92/42 EEC LVD EN 60335-1 EMC 89/336/EEC.

The matched pressure jet burner which is exceptionally quiet in operation, ensures clean and efficient combustion with low NO_x emissions

The EuroStar boilers are suitable for all normal open vented central heating and indirect hot water systems but can also be used with sealed systems up to a working pressure of 3 bar with the appropriate sealed system safety equipment. Two flow and return sockets are provided to facilitate connection to the heating and hot water systems.

On the 50/90 model, servicing can be carried out from the front of the boiler. The front mounted flue-cover permits easy access for the removal of the flue-baffles and cleaning of heating surfaces.

The boiler is fully automatic in operation and incorporate all necessary safety controls to ensure safe and reliable operation.

Trianco EuroStar boilers are supplied with the burner set for Kerosene 28 sec. Class C fuel to meet the Building Regulation requirements for low level flue discharge.

Important Notice:

To comply with regulations in force, your new boiler must be installed and commissioned by an *OFTEC*-registered engineer. The installation must also comply with current *Building Regulations, Part L*.

Failure to meet the terms of these requirements may invalidate your guarantee.

THE PERSON(S) WHO INSTALLS THIS APPLIANCE, COMMISSIONS, SERVICES OR CARRIES OUT ANY REMEDIAL WORK, IE ELECTRICAL FAULT FINDING, MUST HAVE SUITABLE ENGINEERING QUALIFICATIONS

3. TECHNICAL INFORMATION

NOTE: ALL DIMENSIONS IN MM

MODEL	H	W	L	L+
50/90	920	500	705	1015
95/115	980	500	765	1075

MODEL	X	Y	Z
50/90	195	503	255
95/115	195	559	255

FLOW & RETURN SOCKET SIZES

MODEL	A
50/90	1"
95/115	1 1/4"

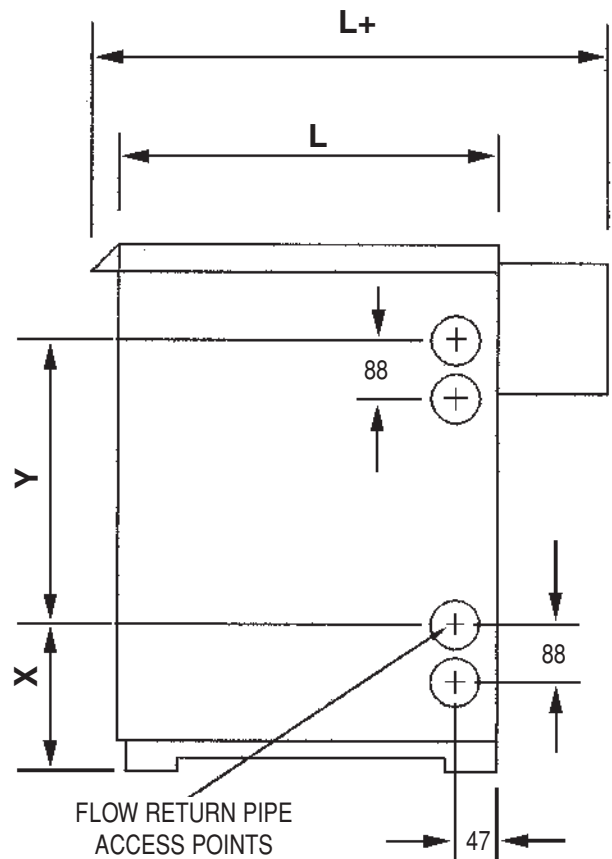

SIDE VIEW

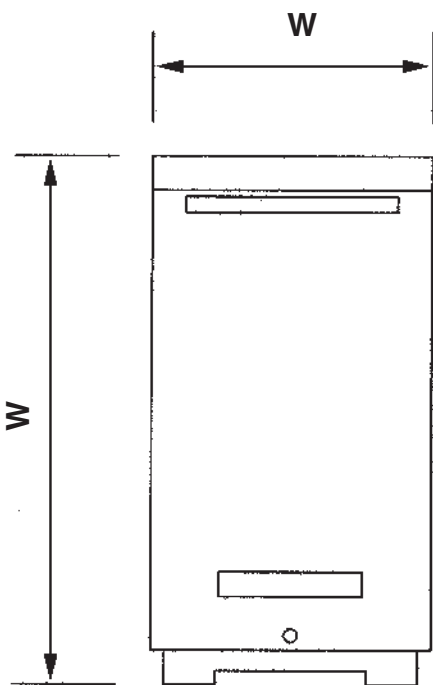

FRONT VIEW

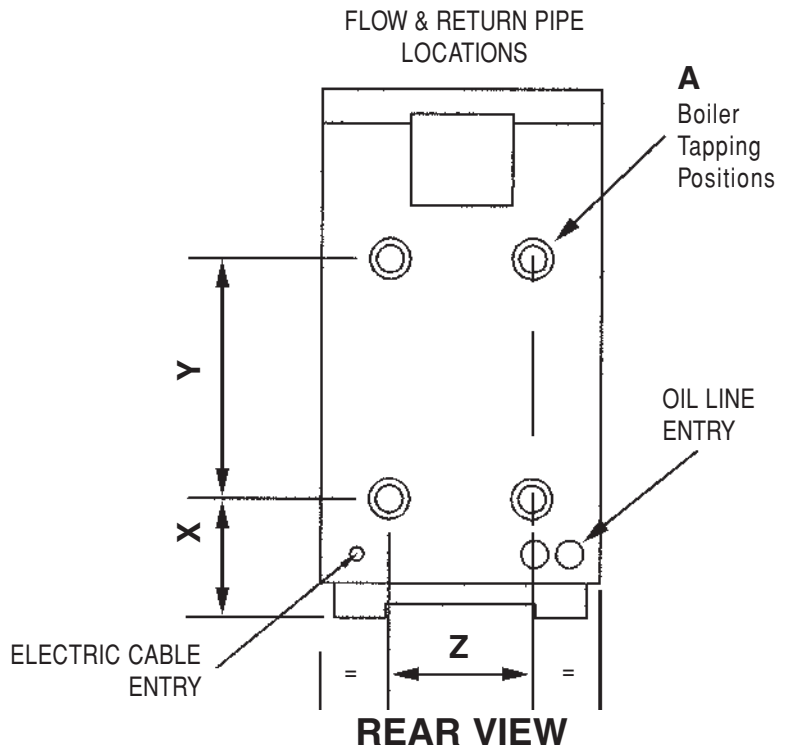

REAR VIEW

Fig. 1 OUTLINE DIMENSIONS

Technical Specification

EuroStar Boiler Models		50/90	95/115
Rated Input	(Btu/h) (kW)	98,000 28.6	127,700 37.4
Rated Output	(Btu/h) (kW)	90,000 26.4	115,000 33.7
Burner		See Burner Details Leaflet	See Burner Details Leaflet
Weight (empty)	(kg)	100	130
Water content	(litre)	22	30
Flow & return sockets	(in.)	4 x 1 BSP	4 x 1 1/4 BSP
Max. operating pressure	(bar) (psi)	3 43.5	3 43.5
Test Pressure	(bar) (psi)	4.5 65.3	4.5 65.3
Water side resistance 10 diff 20 diff	(mbar) (mbar)	25.0 8.3	25.4 8.2
Starting Current	(amp)	3.5	3.5
Running Current	(amp)	0.77	0.77
Control Thermostat	- Adjustable up to 82°C		
Limit Thermostat	- Factory makes at 110° C (hand reset)		
Frost Stat	- Make at 5°C		
Casing Finish	- Galvanised steel stove enamelled green		

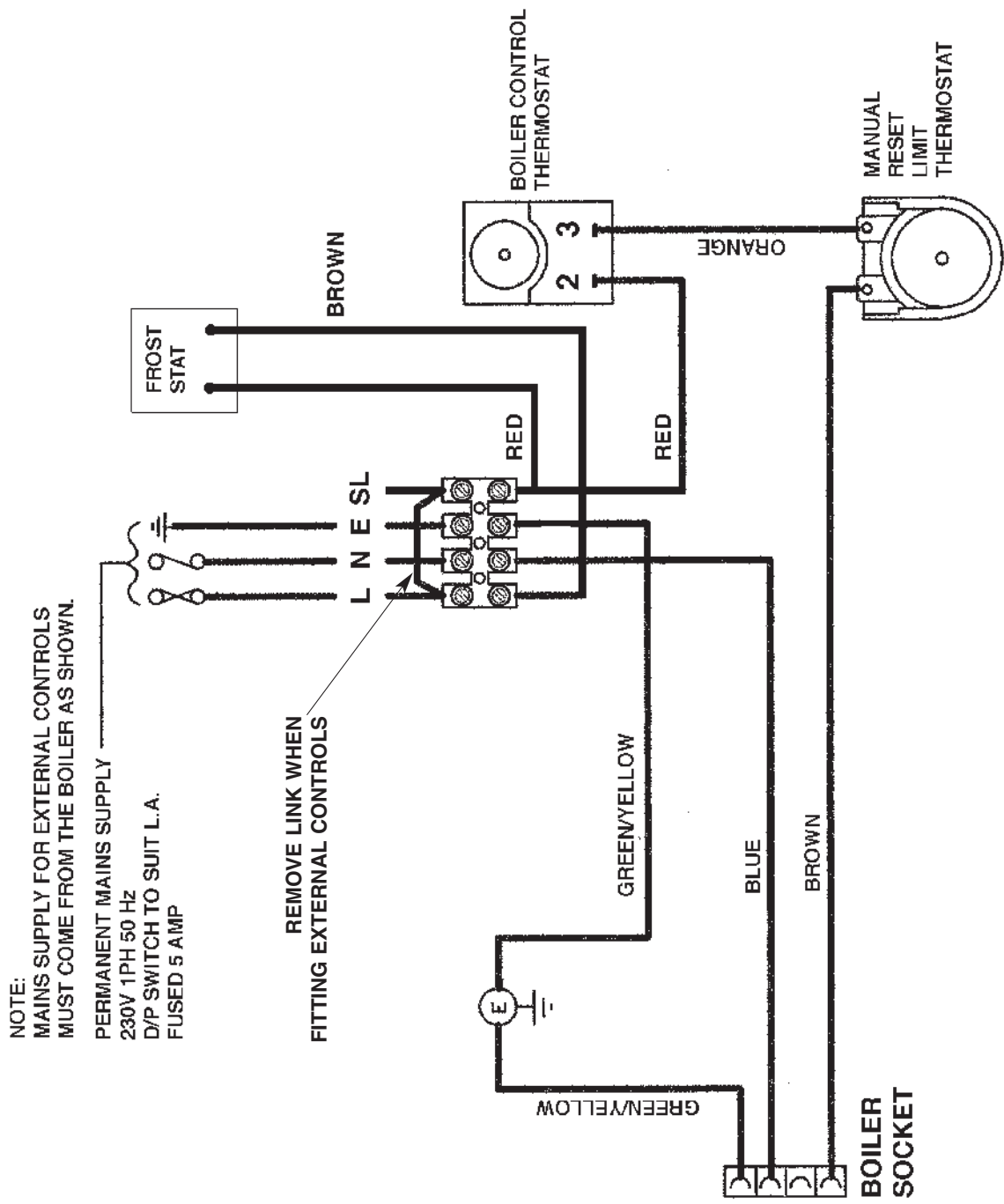

FIG. 2 WIRING DIAGRAM - EXTERNAL MODEL

4. INSTALLATION

Regulations

Installation of the boiler must comply with the following British Standards and Regulations:

BS 5410: Part 1 - Code of Practice for Oil Firing.

BS 5449 - Forced Circulation Hot Water Central Heating Systems.

The Building Regulations - Part 'J' (England and Wales)
Part 'F' Section 111(Scotland)
Part 'L'

The Control of Pollution (Oil) Regulations
Current I.E.E. Regulations
Local Water Undertakings By-laws
OFTEC Installation Requirements for Oil Fired Boilers
and Oil Storage Tanks.

Health and Safety at Work Act

The installer should be aware of his responsibilities under the Act and provide, where necessary, appropriate protection for persons carrying out the installation.

In the interest of safety, the boiler should be installed and commissioned by an OFTEC trained and registered engineer.

A useful guide to 'Safe Working Practices for Oil Firing Technicians' is published by OFTEC.

ELECTRICAL WORK SHOULD BE CARRIED OUT BY A QUALIFIED ELECTRICAL ENGINEER

Siting the Boiler

ALWAYS SITE THE BOILER IN A WELL DRAINED AREA, DO NOT SITE THE BOILER IN AREA WHICH WILL RETAIN WATER.

Sound Levels

- (a) Some people are particularly sensitive to even low noise levels so this aspect should be discussed with the householder.
- (b) Low level flue terminals produce some exhaust noise, so care should be taken when siting adjacent to neighbouring property.

Clearance and Service Access EuroStar 50/90

When siting the boiler, (see terminal position diagram) ensure adequate clearance is allowed for making water connections, and allow at least 1 metre so that the boiler can be full serviced from the front.

Hearth

The Boiler **MUST** be fitted on a suitable non-combustible base that should be substantial enough to support the weight of the boiler and its water content. It should also be noted that the base level should be above ground level to prevent water damage.

Combustion Air (*Conventional flue boilers*)

The provision of an adequate supply of combustion air is essential for the efficient and safe operation of the boiler. The combustion air inlet is located at the top of the front panel which under no circumstances should be covered or blocked.

Heating and Domestic Hot Water Systems

The heating system should be installed in accordance with current HVCA Codes of Practice and BS 5449 Part 1 'Forced Circulation Hot Water Systems'.

All exposed pipework connecting the boiler to the heating system must be lagged.

Water connections can be made to the boiler using both pairs of flow and return tapplings or, alternatively, single diagonally opposite tapplings can be used. Fig. 3

Fit drain-off cock in the lowest part of the system.

Where a boiler is also used for providing domestic hot water, a double feed indirect cylinder to BS 1566 Part 1 must be used.

MAKE SURE ALL UNUSED BOILER TAPPINGS ARE PLUGGED BEFORE FILLING THE SYSTEM.

Flush out the system to remove any swarf or residues before fitting circulating pump.

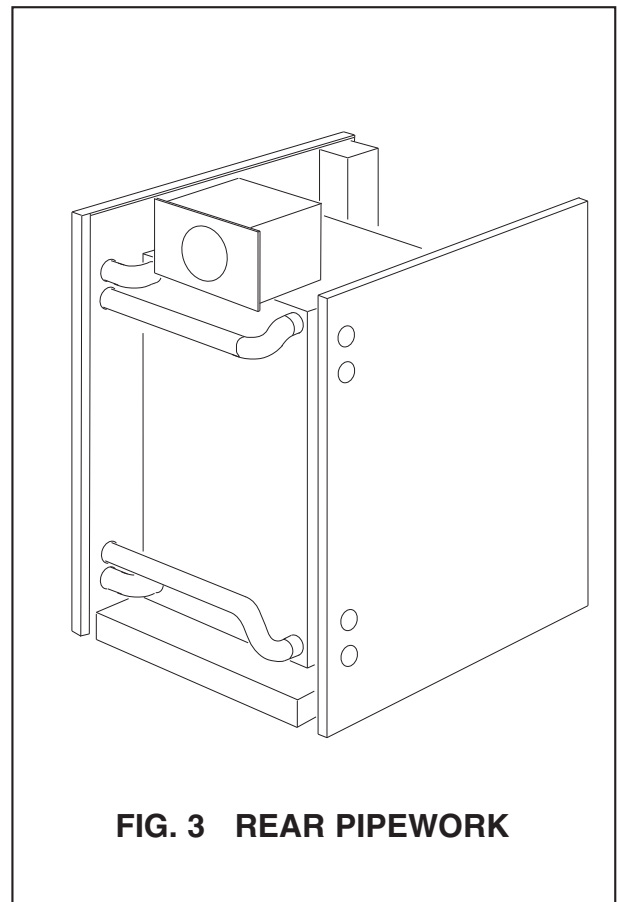

FIG. 3 REAR PIPEWORK

Electrical Supply

230V 1 Phase 50Hz (Fused 5 Amp)

Note: THIS APPLIANCE MUST BE EARTHED

All electrical wiring must be carried out by a qualified electrician in accordance with current I.E.E. Regulations and any Local Regulations that may apply.

The 230v - 50Hz electrical supply must be fused by a double pole switch with a contact separation of at least 3mm in both poles, and shuttered socket (both complying with the requirements of BS 1363) adjacent to the boiler. Fuse supply at 5A. The minimum requirement for the power supply cable should be a PVC sheathed flexible cord, at least 0.75mm² (24x0,2mm) (code designation H05 VV-F or H05 VVH2-F) as specified in table 16 of BS 6500.

This appliance MUST be earthed and the electrical supply earth cable must be of a greater length than the current carrying conductor cables (ie live and neutral supply cables).

All external cables entering the control box must be secured in position by strain relief bushes supplied (see diagram on how to secure cable).

Terminal connections are also provided in the control panel for ancillary controls.

See wiring diagram Fig. 2

Warning - High and Low Voltage

In certain parts of the country, where there is a known risk of high or low voltage fluctuations, the oil burner shall be prevented from starting by the use of a voltage sensitive device if the voltage drops or increases sufficiently to endanger the installation.

Thermostats

The boiler is fitted with a variable setting control thermostat and a pre-set limit thermostat. Should the boiler thermostat malfunction, the limit thermostat will take over control and shut down the boiler.

Frost Protection

The boiler is fitted with a frost thermostat, which will activate the burner should ambient temperature fall to 5°C, the thermostat will automatically cut off on temperature rise. There is no manual adjustment.

If the system is shut down for a long period during very cold weather, it is advisable to completely drain the system. However, frequent draining should be avoided, especially in hard water areas, as this could lead to scaling of the boiler waterways.

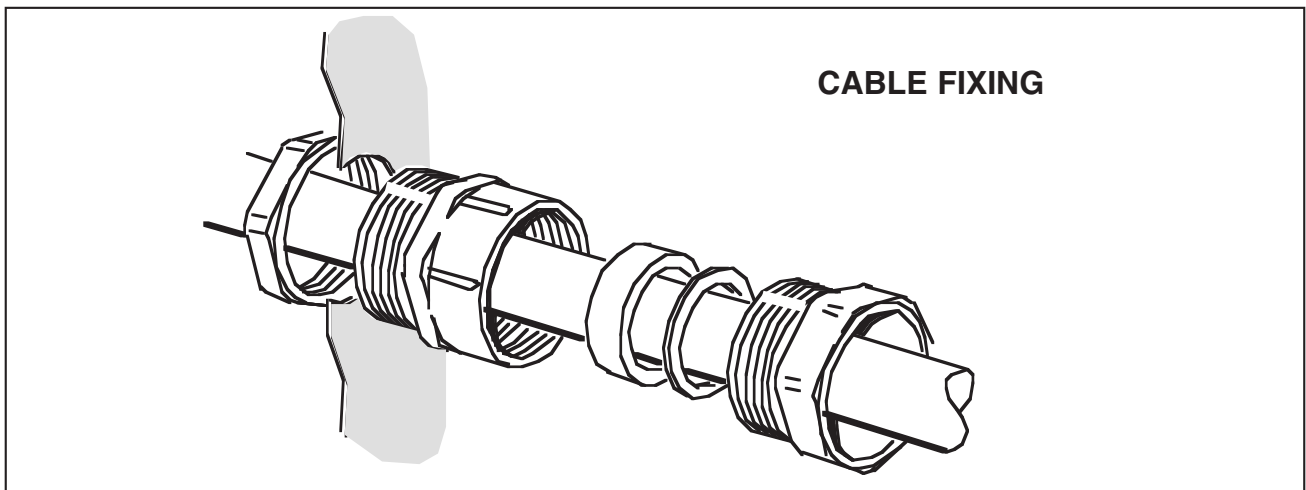

5. OIL SUPPLY

Note: The oil burner is factory set to burn 28 sec. Kerosene.

Note: Only Kerosene is permitted for low level flue discharge.

Oil Storage Tanks

The tank must not be installed within 3 metres of the boilers terminal.

Size and Location of Tank

The tank should be large enough to allow for economic deliveries and be located in the most unobtrusive position, having regard to the need for safety, filling, maintenance (if steel tank) and the head of oil required.

Whilst it is highly unlikely that a fire could start from a domestic oil tank, it does however need to be protected from a fire that may originate in a nearby building, therefore the tank should not be located nearer than 1.8 metres from a building, nor closer than 760mm from a site boundary. Where a tank has to be less than 1.8 metres, the building wall must not have any openings other than small ventilation openings. The wall shall have a half hour resistance to an internal fire and extend 1.8 metres from any part of the tank.

Alternatively, a non-combustible radiation barrier must be provided which meets the requirements of BS 5410 Part 1: This standard applies to tanks up to a capacity of 3,400 litres which is deemed the maximum size for a single family dwelling.

Steel Tanks

Steel tanks should comply with the requirements BS 799, Pt. 5: 1987 and mounted on brick or block piers with a waterproof membrane between the piers and tank.

The tank should be fitted with fill and vent connections (weather protected), a drain-off cock, shut-off valve and an oil level indicator.

Plastic Tanks

Polyethylene tanks are now widely used because of their advantages over traditional steel tanks:

- (a) They do not need pier supports and can be mounted directly on any flat surface giving uniform support for the tank base.
- (b) They do not corrode and therefore never need painting.
- (c) They are easier to handle because of their lower weight.
- (d) They have a 10 year manufacturer's guarantee.

Plastic tanks should be fitted with similar components to those used with steel tanks.

Fire Protection

To comply with building regulation **Section J5**:

- 1 Where a storage tank is close to a dwelling, fire cladding must be provided to the eaves, if less than 1.8m from the top of the tank.
- 2 The cladding must extend 300mm beyond the tank.
- 3 The tank must be sited on a non-combustible base.

Pollution Protection

To comply with building regulation **section J6**, the tank must be 'bunded' (i.e. double walled) if:

- 1 The tank is less than 10m from a stream.
- 2 The tank is less than 50m from a well, spring, or drinking water.
- 3 The tank cannot be viewed from the delivery point.
- 4 In the event of a leak, there is a risk of oil reaching a manhole cover or drain.
- 5 The tank capacity exceeds 2500 Litres.

Oil supply line

A long life flexible oil hose is supplied with the boiler. A filter and shut-off valve are also required. These should be fitted as shown in Figs. 4 and 5.

The oil shut-off valve should be fitted as close to the burner as practicable to enable the burner to be disconnected without undue loss of oil. The filter must be connected in the oil supply pipe and positioned as close to the oil tank as possible.

Fire Valve

A fire-valve must be fitted in the oil line outside the building with its sensing phial positioned within the boiler casing below the control panel. A clip is provided for retaining the phial.

All oil line joints must be completely sealed and the total pipe run thoroughly flushed out before connecting to the burner. No soldered joints are permitted in the oil line.

The oil line can be fed into the back of the boiler base tray or through the holes at the side.

Single pipe oil supply (Fig. 4)

When the bottom of the oil supply tank is above the burner, a single pipe gravity system can be used. The oil supply pipe must be connected to the suction port on the burner pump via the flexible hose.

Two pipe oil supply (Fig. 5)

Where the bottom of the oil storage tank is below the burner, a two pipe suction lift system is necessary.

When using a two pipe system, it is important that the by-pass screw is fitted, on the BFP II pump remove the end cover and filter, then remove the 'U' washer by unscrewing the bottom screw, then replace the screw ensuring it is fully inserted. An additional flexible hose is also required.

A spring loaded non-return valve must be fitted in the suction line to stop the oil running back to the tank. A filter, shut-off valve and fire valve must also be fitted in the line.

No valves are permitted in the return line which must remain unobstructed at all times.

Notes:

- (1) The pump suction should not exceed 0.4 bar, otherwise dissolved gas will be released from the oil to affect combustion.
- (2) The return pipe must end at the same level as the suction outlet to prevent loss of prime.
- (3) The outlet from the tank should be approximately 75mm (3 in) above the bottom to prevent sediment and water being drawn into the supply pipe.

Oil De-aerator - Single pipe supply (Fig. 6)

Where a two pipe suction lift system is required, but the return pipe is too long, or impractical to run, an Oil De-aerator can be used. The burner is piped as for a two pipe system up to the Oil De-aerator but only a single pipe is required to be run back to the oil storage tank. A non-return valve is not required with this system but the bypass plug must be fitted in the pump as for a two pipe system.

MAXIMUM OIL SUPPLY LINE LENGTH 'L'

HEAD 'H' METRES.		.0.5	1.0	1.5	2.0	2.5	3.0	3.5	4.0
PIPE 6mm ID	MAXIMUM LENGTH (METRES)	10	21	31	41	52	62	73	83
PIPE 8mm ID		33	66	98	100	100	100	100	100

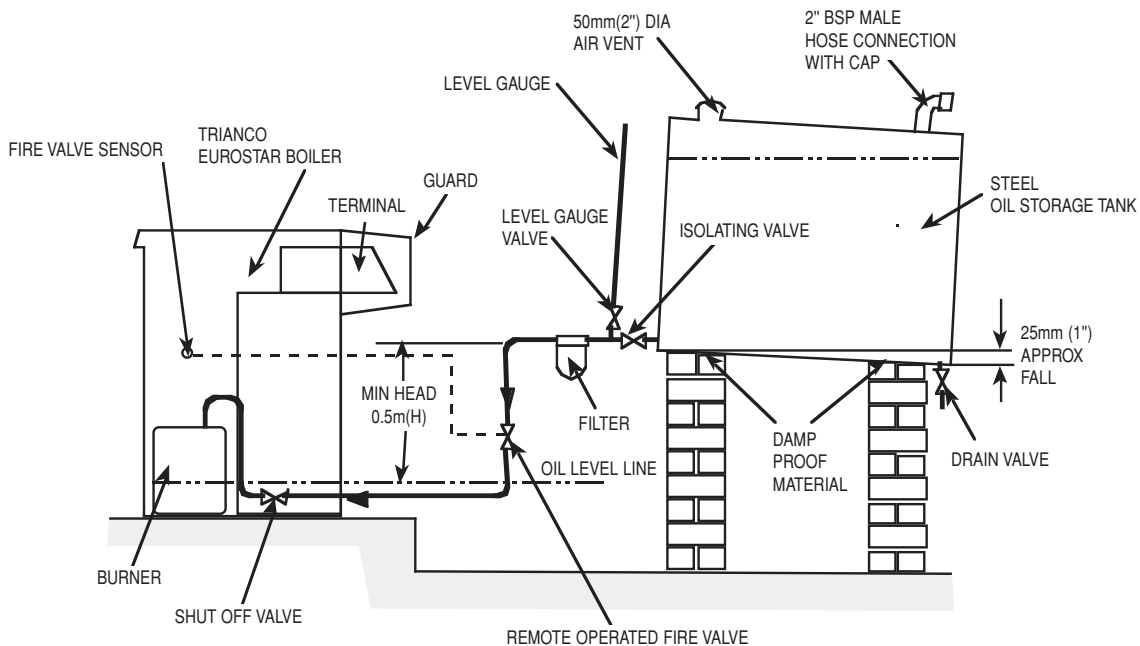

FIG. 4 SINGLE PIPE OIL SUPPLY INSTALLATION

MAXIMUM OIL SUPPLY LINE LENGTH 'L'

LIFT 'L' METRES.		.0.5	1.0	1.5	2.0	2.5	3.0	3.5	4.0
PIPE 6mm ID	MAXIMUM LENGTH (METRES)	48	42	36	30	24	18	11	5
PIPE 8mm ID		100	100	100	94	75	55	36	16
PIPE 10MM ID		100	100	100	100	100	100	88	40

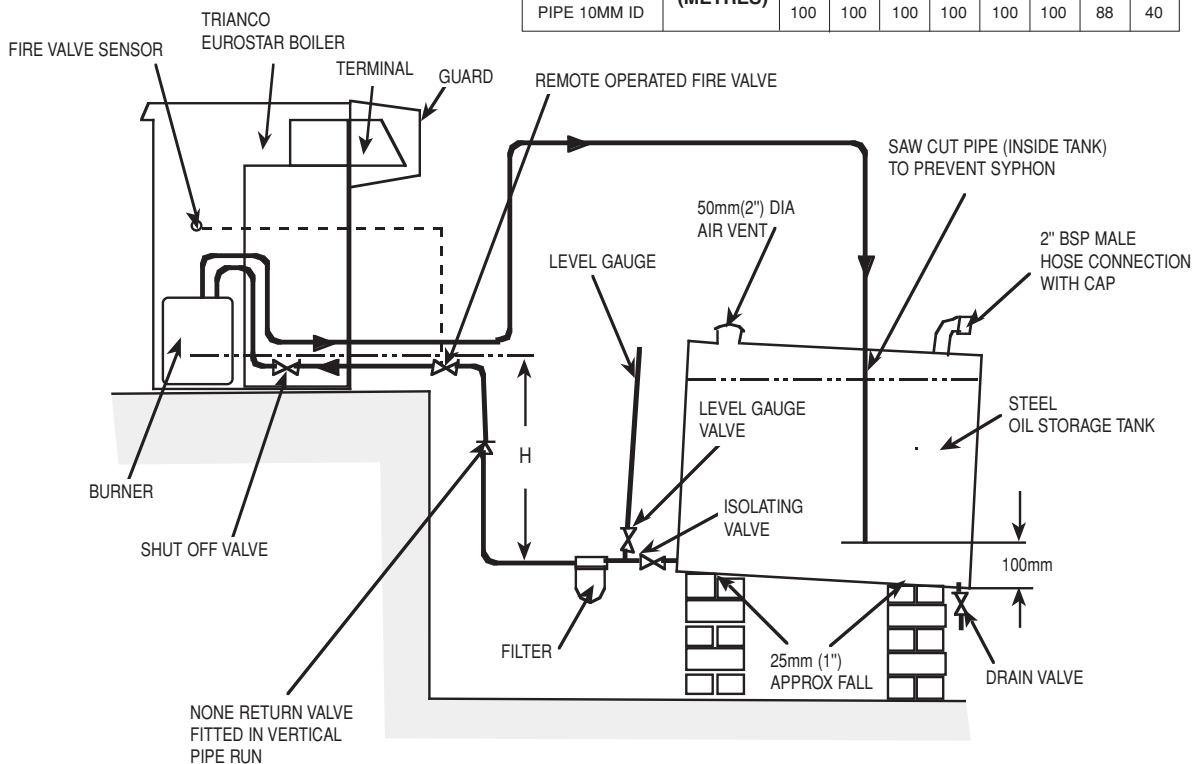
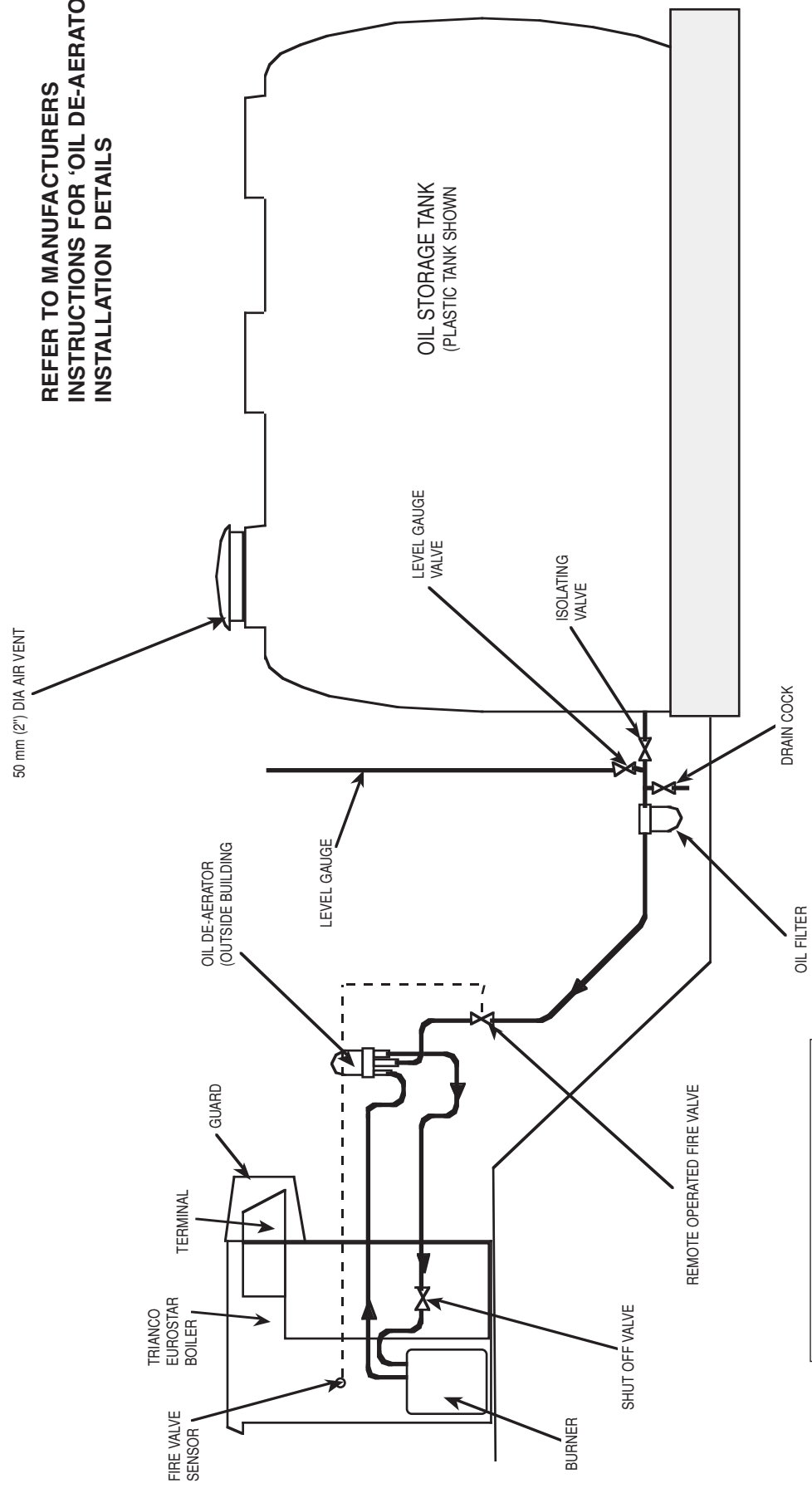

FIG. 5 TWO PIPE OIL SUPPLY INSTALLATION

REFER TO MANUFACTURERS
INSTRUCTIONS FOR 'OIL DE-AERATOR'
INSTALLATION DETAILS



NOTE
OIL DE-AERATOR MUST BE
INSTALLED UPRIGHT.
IT MAY BE ABOVE OR
BELOW BURNER,
OUTSIDE BUILDING

FIG. 6 DE-AERATED OIL SUPPLY INSTALLATION

6. FLUE SYSTEMS

To evacuate the products of combustion safely and thoroughly, the boiler must have an efficient flue system. The design and construction of the Trianco Flue already takes these factors into account .

INSTALLATION NOTES

(a) Location (Fig. 7)

Modern low level flue boilers are designed to operate at low noise levels. However, when positioning your boiler, it is not recommended to have the terminal facing a neighbours property or patio etc. It should also be positioned to avoid products of combustion entering the building.

A distance of at least 600mm must be allowed between the terminal and any window, door or other opening into the building, (see diagram for recommended terminal positions).

(b) Flue Sealing

As the flue system operates under positive pressure, it is essential to seal all flue joints. Apply a thin bead of silicone sealant (supplied) around flue pipe spigot before inserting into socket.

(c) Fuel

Only Kerosene 28 sec. Class C2 is permitted for boilers using low level flue discharge.

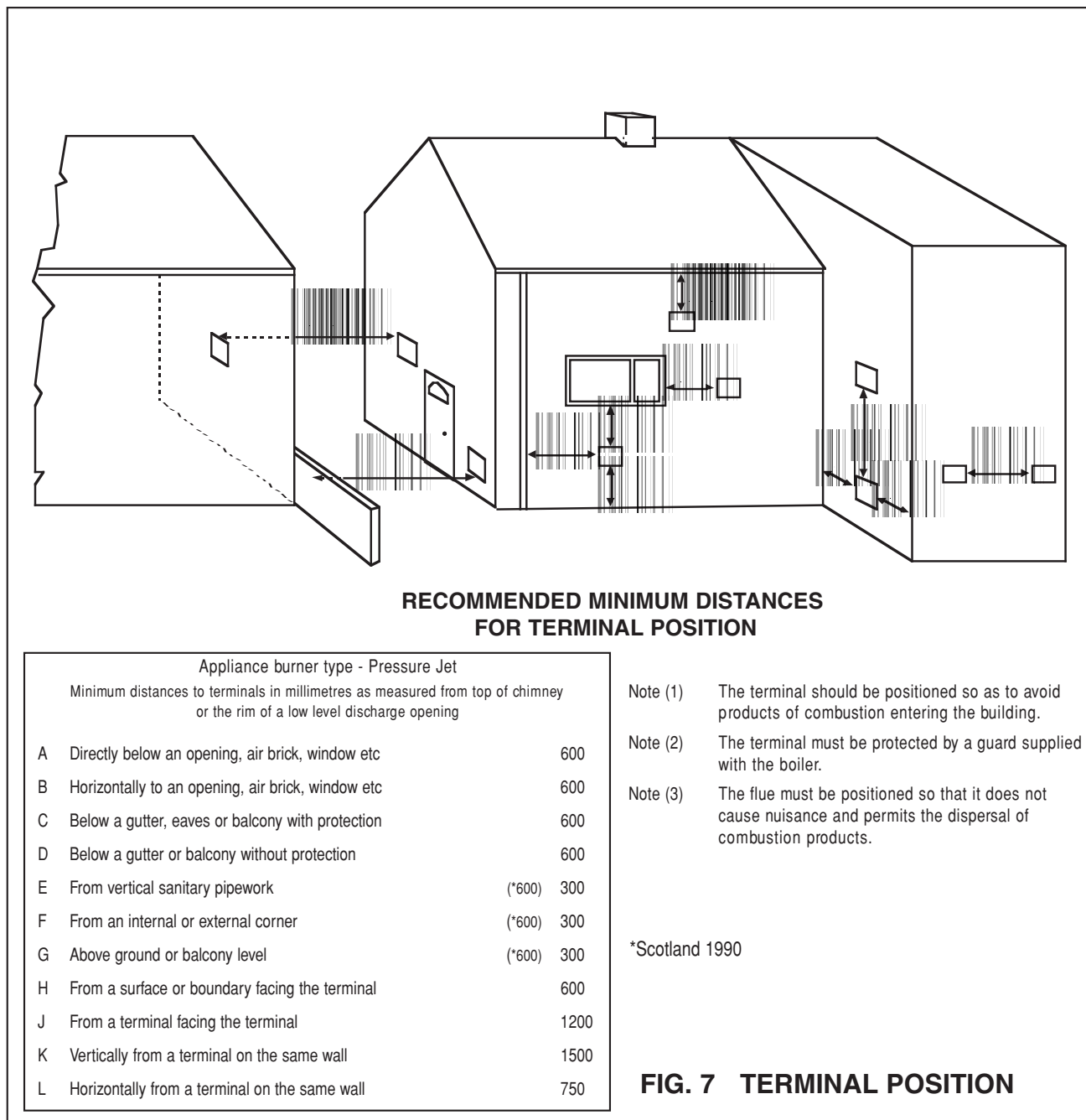

FITTING THE FLUE TERMINAL

- 1 With the back panel (item 1) removed for connecting the pipework, place the gasket (item 3) up to the acoustic box (item 2) using the M6 studs for location.
- 2 Fit the back panel (item 1) in position and secure with the 9xM5 screws provided
- 3 Place the second gasket (item 4) up to the back panel
- 4 Fit the terminal box (item 5) with the discharge pointing downwards and secure with the 4xM6 nuts.
- 5 Fit the terminal guard (item 6) using the 4xM5 screws

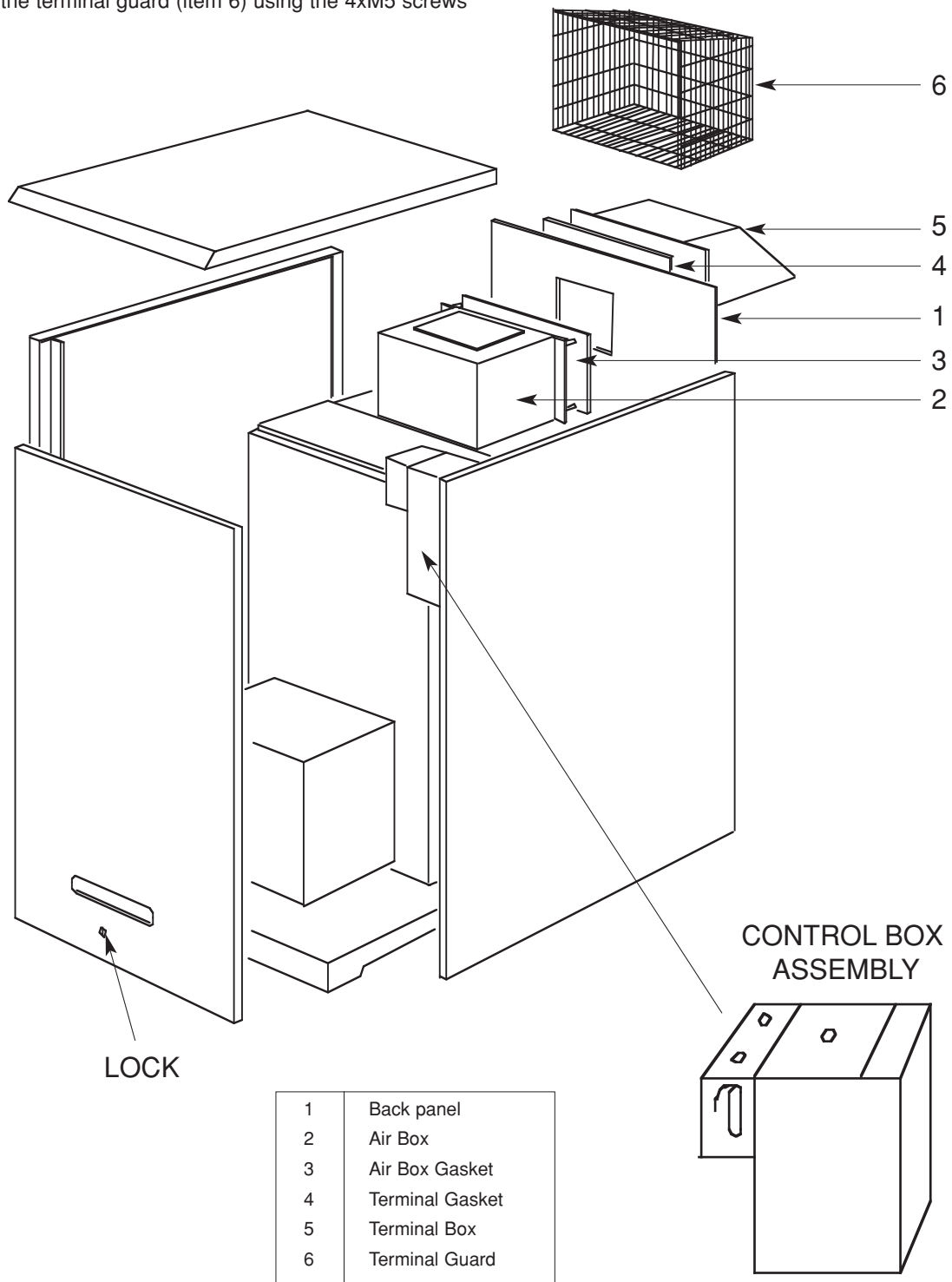

FIG. 8

7. COMMISSIONING

It is strongly recommended that the boiler/burner unit is commissioned by a qualified technician, preferably OFTEC trained and registered.

It is the responsibility of the installer to ensure the boiler is properly commissioned, failure to do so will make the boiler's guarantee and any extended warranty null and void.

Although all burners are factory tested before despatch, they will usually need further air adjustment to achieve the readings indicated in 'Burner detail leaflet' because of site variations in flue draught and back pressure.

Procedure

1. Switch off electrical supply to the boiler.
2. Ensure boiler is full of water and all valves are open.
3. Remove flue-cover and check that flue-baffles are correctly positioned (See Fig 9 for baffle arrangement).
4. Disconnect oil hose from burner, open shut-off valve and run off a quantity of oil into a container to check for a clean air free supply then reconnect hose. (This applies to single pipe gravity system only).
5. Check that the time-switch (if fitted) is in the ON position and room and boiler thermostats are calling for heat.
6. Switch on electrical supply and the burner should start.

Note: The burner may lock-out on first firing due to air in the pump, if this happens, wait about a minute before pressing reset button to restart burner. If a further lock-out occurs, the air should be bled from the pump pressure gauge connection.

7. Start and stop the burner two or three times until the flame cuts off sharply - this indicates any remaining air has been dispersed.
8. All the burner to run for about 15 minutes, then take a CO₂ reading through the sampling hole in flue-cover. Compare the reading with that given under 'Burner Settings' and adjust the air setting if necessary to achieve the required CO₂%. Also, check the smoke and flue gas temperature.

Handing Over

After completing the boiler installation, the installer should make a thorough check of the system to ensure it is completely satisfactory and demonstrate to the user the operation of the boiler and any system controls.

All instructions should be handed to the user for retention and advice regarding the need for annual servicing.

8. SERVICING

IMPORTANT: ISOLATE ELECTRICAL SUPPLY TO THE BOILER BEFORE SERVICING

To maintain the boiler's high thermal efficiency and reliable operation, it should be serviced annually by a qualified engineer preferably OFTEC trained and registered. Electrical work should be carried out by a qualified engineer.

If the boiler is used to provide central heating and hot water all year round, the best time for its annual service is just before the start of the heating season.

Where the boiler is shut down for the summer months, the service should be carried out as soon as possible after the end of the heating season.

Oil tank

Open tank drain-cock to draw off any accumulated water and sludge.

Line filters

Turn off oil supply and remove filter bowl. Wash filter element clean with kerosene.

Casing

Check the external surfaces of the casing for corrosion, if corroding clean down and apply a suitable material to protect the surface.

Servicing the Boiler (Burner removed)

1. Remove flue-cover and lift out flue-baffles
(See Fig. 9).
2. Brush all deposits from flue-baffles and internal surfaces of the boiler.
3. Remove flue deposits from the combustion chamber floor using a vacuum cleaner.

4. Replace flue-baffles in the correct arrangement
(See Fig. 9 for order of assembly). Refit the flue-cover and fully tighten wing-nuts to make a gas tight seal.
5. Refit burner to boiler, connect flexible air hose and plug-in burner lead.
6. Turn on oil supply, switch on electricity and burner should fire.
7. Finally check the combustion readings with those given under 'Burner Settings' and make any air or oil pressure adjustments necessary.

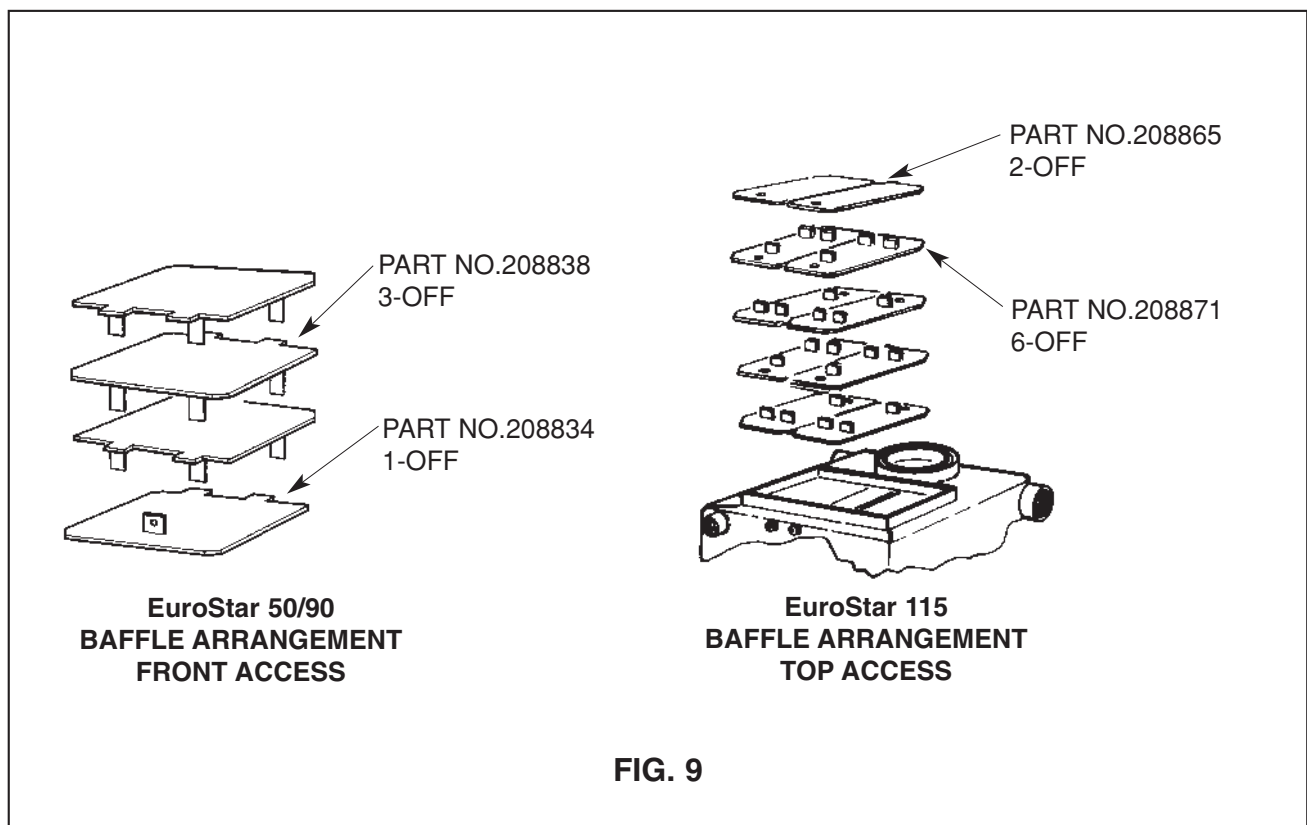

9. FAULT FINDING

ELECTRICITY SAFETY - Before making any electrical checks, switch off mains supply to boiler.

FAULT	POSSIBLE CAUSE	ACTION
BURNER WILL NOT START	Control box locked out	Press reset button on front of burner. N.B. ONLY TRY TWICE
	Limit-stat tripped	Press reset button under control panel and check function of boiler control thermostat.
	Boiler thermostat or other system controls satisfied	Ensure all controls are calling for heat.
	Fuse blown	Fit new 5 amp fuse, if it blows again, check for short circuit in wiring.
	Check for live supply continuity up to burner	If live supply confirmed, change control box
	Motor or pump seized	Check for rotation and replace as necessary.
BURNER STARTS BUT FLAME NOT ESTABLISHED	No oil supply	Check oil level in tank and feed to burner.
	Photo-cell not seeing flame	Clean photo-cell and ensure it is fully plugged in.
	Air trapped in pump	Bleed off air through pressure gauge tapping.
	Solenoid valve faulty	Check coil for continuity and replace if faulty.
	Nozzle blocked	Replace nozzle with one of same specification.
	Electrodes incorrectly set	Reset gap and position electrodes as shown in Burner diagram.
	Electrode insulator cracked	Check and replace if insulator cracked or crazed.
	Ignition transformer and H.T. contacts	Check for spark and condition of H.T. contacts. Replace as necessary.
	Low oil pressure	Check pump pressure and adjust to correct setting.
FLAME ESTABLISHED BUT BURNER LOCKS OUT AFTER FEW SECONDS	Oil contaminated with water	Run off oil at burner until free of water and drain condensation from tank
	Oil filter partially blocked	Wash filter clean with kerosene.
	Photo-cell fault	Clean photo-cell and ensure it is fully plugged in. Replace if faulty.
	Oil pressure low	Check pump pressure and adjust to correct setting.

FAULT FINDING (Cont'd)

FAULT	POSSIBLE CAUSE	ACTION
POOR FLAME CUT-OFF	Air in pump or at back of nozzle	Bleed pump through pressure gauge port, also check for leaks in oil line if 2-pipe system.
	Oil contaminated with water	Run off oil at burner until free of water and drain condensation from tank.
	Dirt in solenoid valve	Clean or replace valve.
	Pump shut-off piston sticking	Replace pump.
MORNING START LOCK-OUT	Faulty non-return valve or air leak in two pipe system	Replace non-return valve and cure leak.
	Low voltage	Check with local Electricity Board.
	Combustion readings incorrect	Check combustion under normal running conditions and compare readings with those given under 'Burner Settings'.
	Oil level in tank falling below burner	Raise tank or fit a 2-pipe system.

EuroStar Boiler Parts

Description	No. Off	50/90	95/115
Boiler Body	1	222420	222430
R/H Side Panel Assembly	1	210801	210781
L/H Side Panel Assembly	1	210800	21780
Top Panel Assembly	1	210806	210782
Back Panel	1	210808	210784
Boiler Control Thermostat	1	206896	206896
Limit Thermostat	1	206892	206892
Gasket	1	210846	210846
Baffle W.U. Top	1	208838	-
Baffle Plate Top	2	-	208865
Baffle W.U. Bottom	3	208834	-
Baffle W.U.	6	-	208871
Flue Cover Assembly	1	208803	208876
Control Box Assembly	1	210799	210799
Base Plate	1	210807	210784
Frost Thermostat	1	209735	209735
Front Door Assembly	1	210873	210785
Burner Assembly	1	221330	221370



By appointment to H.M. Queen Elizabeth
The Queen Mother
Manufacturers of Domestic Boilers



TRIANCO LIMITED
Thorncliffe, Chapeltown, Sheffield S35 2PH
Tel: Sheffield (0114) 257 2300
Fax: (0114) 257 1419
www.trianco.co.uk



© Trianco Limited, Copyright in this brochure and the drawings or illustrations contained in it is vested in Trianco Limited and neither the brochure or any part thereof may be reproduced without prior written consent.

Trianco Limited's policy is one of continuous research and development. This may necessitate alterations to this specification.