



INSTALLER GUIDE

HEARTBEAT

OXYSAFE 2

MODEL 339

(GC No. 32-032-29)



***LIVE FUEL EFFECT
GAS FIRE***

**THIS APPLIANCE IS FOR USE WITH NATURAL GAS (G20)
THIS APPLIANCE IS FOR USE IN THE UNITED KINGDOM (GB) AND
THE REPUBLIC OF IRELAND (IE) ONLY.**

We trust that this Installer Guide gives sufficient details to enable the appliance to be installed and maintained satisfactorily. However, if further information is required, our **Valor Technical Helpline** will be pleased to help.

Please telephone 08706 061 065 (National call rates apply in the United Kingdom).

INSTALLER: Please leave this guide with the owner

INSTALLER'S GUIDE

CONTENTS

1	APPLIANCE DATA.....	3
2	GENERAL INSTALLATION REQUIREMENTS.....	4
3	UNPACKING & PRE-INSTALLATION PREPARATION	10
	3.1 Unpacking.....	10
	3.2 Fireplace Flue Pull.....	10
	3.3 Appliance Preparation.....	10
	Fit The Closure Plate.....	12
4	APPLIANCE INSTALLATION	14
	4.1 Installing To A Hearth.....	14
	4.2 Wall Mounting.....	14
	4.3 Gas Supply Connection	14
	4.4 Fit the Coal and Window.....	14
5	FULL OPERATING CHECKS	15
	5.1 Check Control Settings.....	15
	5.2 Check Burner Pressure.....	15
	5.3 Test For Spillage.....	16
	5.4 Flame Supervision & Spillage Monitoring System.....	16
6	FINAL ASSEMBLY & REVIEW.....	17
	Fit The Outer Case.....	17
	6.2 Final Review.....	17
7	SERVICING & PARTS REPLACEMENT.....	19
	7.1 To Remove Window Unit.....	19
	7.2 To Remove Outer Case.....	19
	7.3 To Remove The Coal.....	20
	7.4 To Remove The Gas Tap.....	20
	7.5 To Remove The Piezo Generator	20
	7.6 To Grease The Control Tap.....	20
	7.7 To Remove An Injector	21
	7.8 To Remove The Complete Burner Module, Pipes and Pilot.....	21
8	REPLACEMENT PARTS – SHORT LIST.....	23



Valor Heating, Erdington, Birmingham B24 9QP
www.valor.co.uk

Because our policy is one of constant development and improvement, details may vary slightly from those given in this publication

INSTALLER'S GUIDE

1 APPLIANCE DATA

This product uses a fuel effect piece containing Refractory Ceramic Fibres (RCF), which are man-made vitreous silicate fibres. Excessive exposure to this material may cause temporary irritation to eyes, skin and respiratory tract. Consequently, it makes sense to take care when handling this article to ensure that the release of dust is kept to a minimum. To ensure that the release of fibres from this RCF article is kept to a minimum, during installation and servicing we recommend that you use a HEPA filtered vacuum to remove any dust and soot accumulated in and around the fire before and after working on the fire. When replacing this article we recommend that the replaced item is not broken up, but is sealed within a heavy duty polythene bag, clearly labelled as RCF waste. This is not classified as "hazardous waste" and may be disposed of at a tipping site licensed for the disposal of industrial waste. Protective clothing is not required when handling this article, but we recommend you follow the normal hygiene rules of not smoking, eating or drinking in the work area and always wash your hands before eating or drinking.

This appliance does not contain any component manufactured from asbestos or asbestos related products.

The appliance data label is on the inner face of the back panel near the bottom left corner. There is also a label giving the serial number and appliance G.C. number on the right side of the outer case near the bottom.

Gas		Natural (G20)
Inlet Pressure		20mbar
Gross Heat Input	at Control Setting	
	4	5.05kW (17,200Btu/h)
	3	3.45kW (11,800Btu/h)
	2	1.80kW (6,100Btu/h)
	1	1.55kW (5,300Btu/h)
Burner Test Pressure (Cold)		17.2±0.75mbar (6.9±0.3in w.g.)
Gas Connection		8mm pipe
Burner Injector	Upper	Bray Cat. 99 Size 115
	Lower	Bray Cat. 99 Size 230A
Pilot & Atmosphere Sensing Device		SIT Ref. OP9419
Ignition		Piezo-electric integral with gas tap
Aeration		Non-adjustable

INSTALLER'S GUIDE

2 GENERAL INSTALLATION REQUIREMENTS

2.1 The installation must be in accordance with these instructions.

For the user's protection, in the United Kingdom it is the law that all gas appliances are installed by competent persons in accordance with the current edition of the Gas Safety (Installation and Use) Regulations. Failure to install the appliance correctly could lead to prosecution. The Council for the Registration of Gas Installers (CORGI) requires its members to work to recognised standards.

In the United Kingdom the installation must also be in accordance with:

All the relevant parts of local regulations.

All relevant codes of practice.

The relevant parts of the current editions of the following British Standards:-

BS 715 BS EN 1806 BS 5440 Part 2 BS 6891

BS 1251 BS 4543 Part 2 BS 5871 Part 1

BS 1289 Part 1 BS 5440 Part 1 BS 6461 Part 1

In England and Wales, the current edition of the Building Regulations issued by the Department of the Environment and the Welsh Office

In Scotland, the current edition of the Building Standards (Scotland) Regulations issued by the Scottish Executive.

In Northern Ireland, the current edition of the Building regulations (Northern Ireland) issued by the Department of the Environment for Northern Ireland.

In the republic of Ireland the installation must also conform to the relevant parts of:

- a) The current edition of IS 813
- b) All relevant national and local rules in force.

2.2 If the appliance is intended to be installed to a chimney that was previously used for solid fuel, the flue must be swept clean prior to installation. All flues should be inspected for soundness and freedom from blockages.

2.3 Any chimney dampers or restrictors should be removed. If removal is not possible they must be fixed in the open position.

2.4 In the United Kingdom (GB) special ventilation bricks or vents are not normally required in the room for this appliance.

In the Republic of Ireland (IE), permanent ventilation must comply with the regulations currently in force.

INSTALLER'S GUIDE

100mm minimum to combustible surface projecting beyond front of appliance
For access purposes a 10mm clearance is necessary to non-combustible surfaces

100mm minimum clearance to all surfaces in all installations

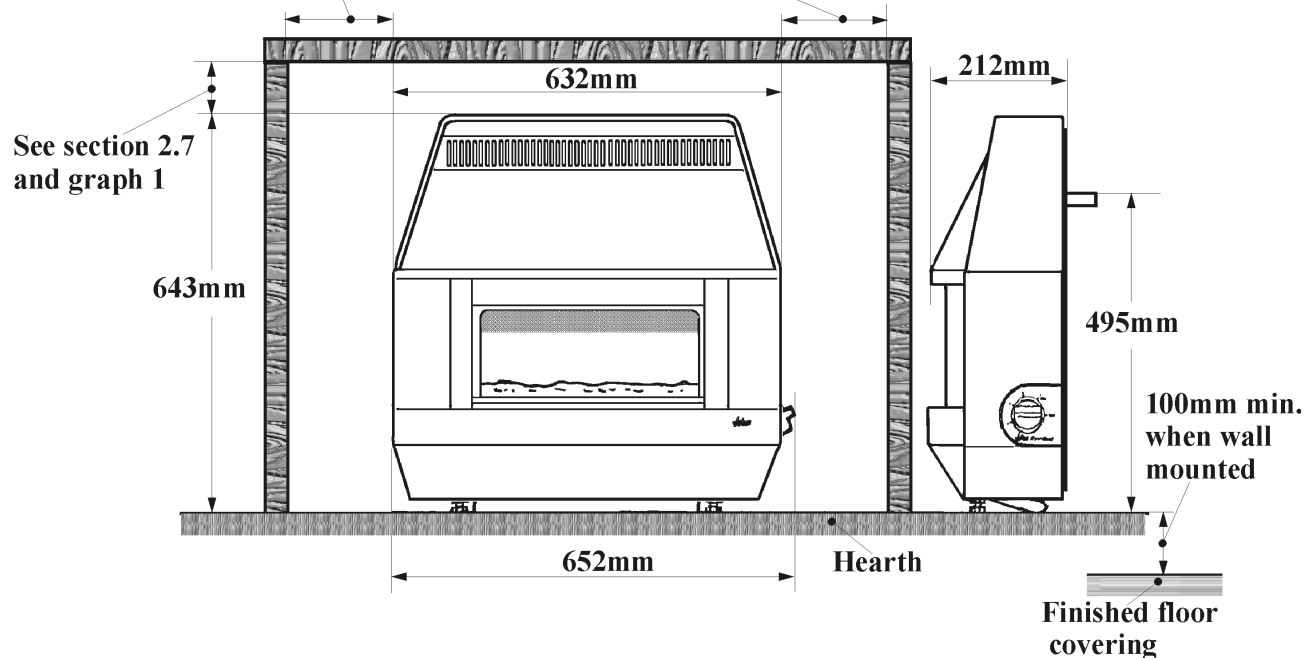

Figure 1 Dimensions & clearances

2.5 Note that soft wall coverings (e.g. embossed vinyl, etc.) are easily affected by heat. They may scorch or become discoloured when close to a heating appliance. Please bear this in mind when installing.

2.6 The appliance must not be installed in any room, which contains a bath, or shower or where steam is regularly present.

2.7 The minimum allowable distance from the outside of the appliance case to a corner wall having combustible material or any other combustible surface which projects beyond the front of the appliance is 100mm at either side.

A clearance of 100mm should be maintained at the right side in all installations to allow satisfactory access to the control knob. For access purposes a clearance from a non-combustible surface of 10mm is necessary at the left side.

See figure 1.

INSTALLER'S GUIDE

2.8. The minimum height required from the top surface of the appliance case to the underside of any shelf made from wood or other combustible materials (see figure 1) is shown in graph 1.

Important: No combustible material (e.g. Wallpaper, plastic tiling, wood panelling etc.) must be used on the fireplace wall below the shelf.

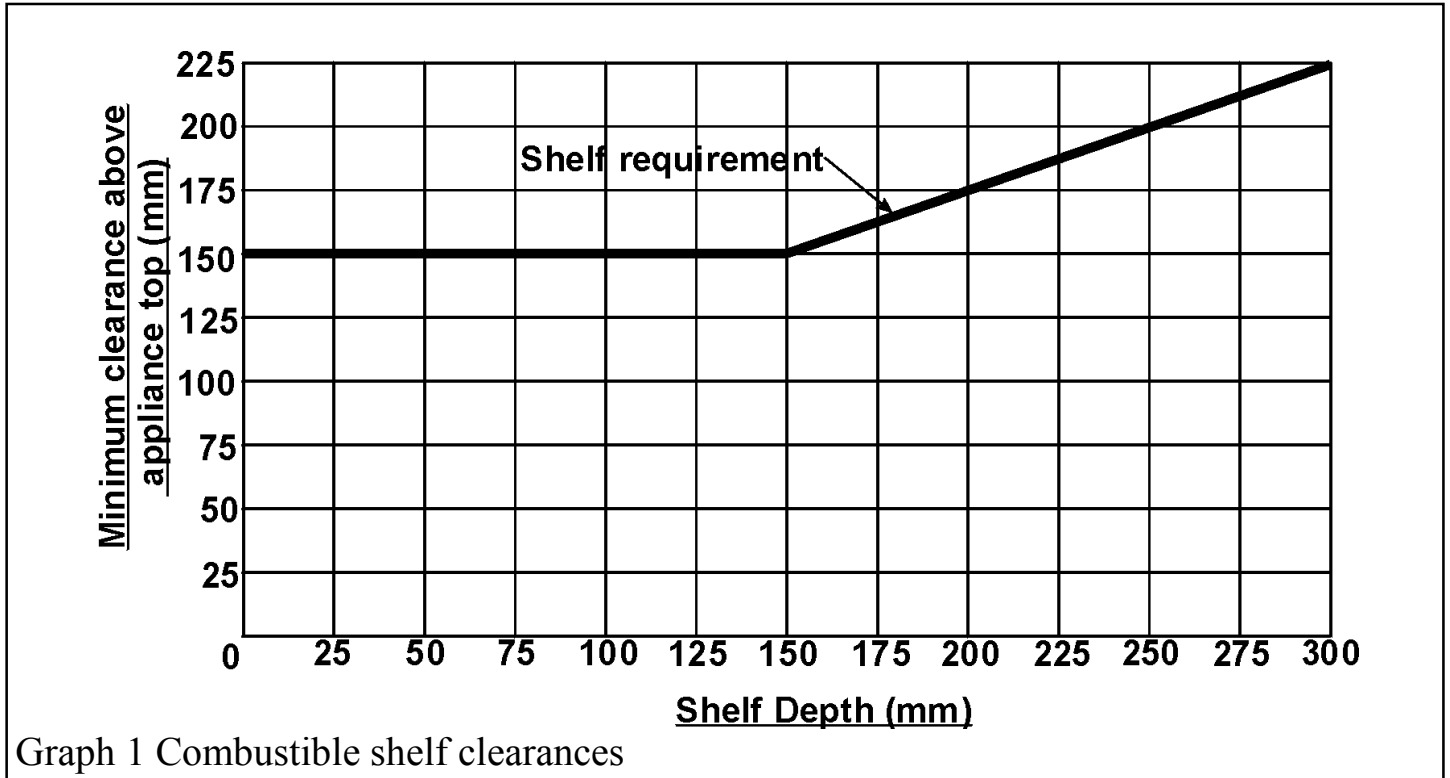

2.9 In the United Kingdom, as supplied, this appliance can be installed in the following situations:-

Note: A spigot extension is available (Valor part number 0595191). When fitted this shall extend through the closure plate for at least 15mm and have a minimum clearance of 50mm from the end to any surface.

2.9.1 Conventional Fireplace and Hearth

The fireplace opening must be within the following dimensions:

Width Max. 432mm Min. 305mm
Height Max. 610mm* Min. 550mm

* Though the total height of the closure plate will accommodate a maximum opening height of 650mm, heights above 610mm will leave the closure plate and sealing tape visible above the appliance.

The appliance must be mounted on a non-combustible hearth (N.B. conglomerate marble hearths are considered as non-combustible). The hearth must be at least 710mm wide x

INSTALLER'S GUIDE

300mm deep. The hearth material must be at least 12mm thick. The periphery of the hearth (or fender) should be at least 50mm above floor level to discourage the placing of carpets or rugs over it.

The appliance can be fitted to a purpose made proprietary class “O” 150°C surround.

2.9.2 Wall Mounted

The wall opening must be within the following dimensions:

Width	Max.	432mm	Min.	305mm
-------	------	-------	------	-------

Height	Max.	610mm*	Min.	334mm
--------	------	--------	------	-------

* Though the total height of the closure plate will accommodate a maximum opening height of 650mm, heights above 610mm will leave the closure plate and sealing tape visible above the appliance.

The bottom of the appliance must be at least 100mm above the finished floor covering. See figure 1. This requires the top of the opening to be at least 650mm above the finished floor covering. Any opening visible below the appliance may be closed in but the depth of the catchment space within the wall opening must be as shown in figure 2.

2.9.3 Precast Flues

The appliance can be installed to a fireplace that has a precast concrete or clay flue block system conforming to BS1289 or BS EN 1806. The appliance is suitable for installations conforming to older versions of BS1289 as well as the current standards. The flue blocks must have a minimum width not less than 63mm and a cross-sectional area not less than 13,000mm². Older editions of BS1289 required a cross-sectional area of 13,000mm². The current revision of the standard requires 16,500mm². This appliance is suitable in both cases.

The chimney should be at least one or two storeys high but not less than 3m vertical height and be correctly terminated. No mortar fangs between the blocks should be extruded into the flueway. If raking blocks are used, they must be fitted in accordance with the manufacturer's instructions. Mortar must not be allowed to drop down and accumulate in the raked positions.

The fireplace opening must be within the following dimensions:

Width	Max.	432mm	Min.	305mm
-------	------	-------	------	-------

Height	Max.	610mm ¹	Min.	550mm ²
--------	------	--------------------	------	--------------------

¹ Though the total height of the closure plate will accommodate a maximum opening height of 650mm, heights above 610mm will leave the closure plate and sealing tape visible above the appliance.

² Any opening visible below the appliance may be closed in.

2.9.4 Metal Flue Box

A twin wall metal flue box conforming to BS715 with a minimum internal depth of 200mm. Incombustible mineral wool insulation of not less than 50mm thickness must be applied to the top surface of the firebox and it must stand on a non-combustible hearth. There must be an air gap clearance of 50mm all round the outside of the box and above the top insulation to any combustible material.

The opening must be within the following dimensions:

Width: Max. 432mm Min. 407mm
Height: Max. 610mm* Min. 560mm**

* Though the total height of the closure plate will accommodate a maximum opening height of 650mm, heights above 610mm will leave the closure plate and sealing tape visible above the appliance.

**This fire has been tested for use on the "Rite-Vent" 7T95125 metal flue box and found to be satisfactory.

2.10 If the fireplace opening is greater than the acceptable dimensions given in this guide, do not use the back of a fire surround or marble to reduce the opening. This may cause cracking of the surround back or marble.

2.11 The following flues are suitable:

- 225mm x 225mm conventional brick flue.

If a flue liner is used, it must be a minimum of 125mm diameter. The liner must be sealed to the surrounding area above the fireplace opening and to the top of the chimney. An approved terminal must be fitted.

- A properly constructed precast flue conforming to B.S 1289.
- A flue pipe with a minimum diameter of 127mm. See B.S 6461 Part 1 for suitable materials. Metal flue pipes must comply with B.S 715. See section 2.9.4 of this guide for flue box opening sizes.

2.11.1 The flue must conform to BS 5440: Part 1 in design and installation.

The flue, measured from the bottom of the fireplace opening to the bottom of the terminal, shall be not less than 3m in actual vertical height. When calculated in accordance with BS 5440: Part 1 Annex A, the minimum **equivalent** height of the flue shall be 2.0m of 125mm dia. flue pipe.

2.11.2 The flue must be clear of any obstruction and its base must be clear of debris.

2.11.3 The flue must be completely sealed so that combustion products do not come into contact with combustible materials outside the chimney.

2.11.4 The flue must serve only one fireplace.

2.11.5 Proprietary terminals must comply with BS 715 or BS 1289. Any terminal or termination must be positioned in accordance with BS 5440 Part 1 to ensure that the products of combustion can be safely dispersed into the outside atmosphere. Where the appliance is connected to an unlined brick chimney it is generally unnecessary for the

INSTALLER'S GUIDE

chimney pot to be replaced or for a terminal to be fitted unless the flue has a diameter smaller than 170mm.

2.12 If the fireplace opening is an underfloor draught type, it must be sealed to stop any draughts.

2.13 The flue spigot and any spigot extension must be capable of passing through the closure plate by at least 25mm with a minimum clearance of 50mm between its open end and the nearest obstruction.

There must also be a minimum clearance of 165mm between the back of the closure plate and the back of the catchment space. The catchment space below the flue spigot must extend at least 250mm downwards measured from the bottom of the flue spigot. See figure 2.

2.14 If the fire is to be fitted against walls with combustible cladding, the cladding must be removed from the area shown in fig.3.

2.15 The front of the fireplace should be flat over an area sufficient to ensure a good seal with the closure plate. The flat surface should extend for a height equal to that of the closure plate plus 20mm and for a width equal to that of the closure plate plus 40mm.

2.16 An extractor fan may only be used in the same room as this appliance, or in any area from which ventilation for the appliance is taken, if it does not affect the safe performance of the appliance. Note the spillage test requirements detailed further on in this manual. If the fan is likely to affect the appliance, the appliance must not be installed unless the fan is permanently disconnected.

2.17 The space between the fireplace front face and the back of the outer case must not be filled in.

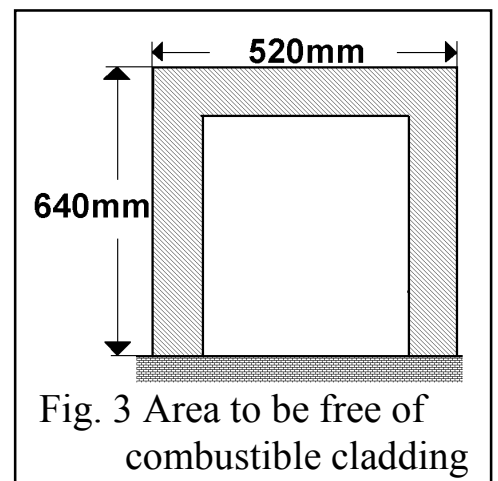
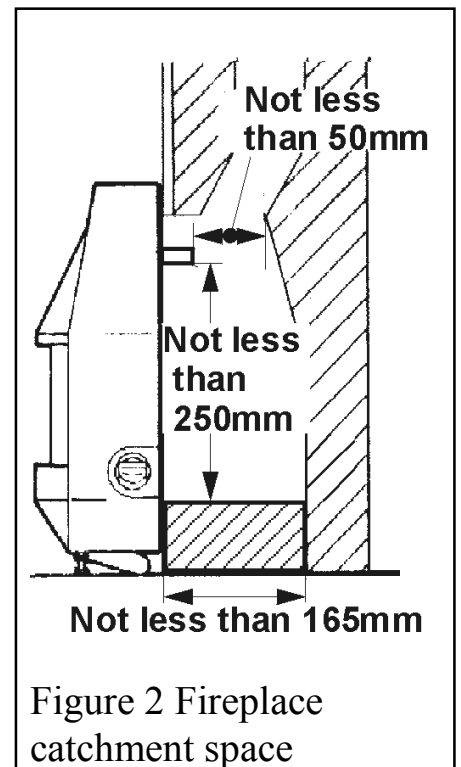

3 UNPACKING & PRE-INSTALLATION PREPARATION

3.1 Unpacking

The carton contains the following:-

1. Fire assembly.
1. Fuel effect (In packaging inside firebox).
1. Closure plate.
1. Smoke match tube.
1. Olive & olive nut for gas line connection
1. Literature pack

Remove all the items carefully to prevent damage. Some items may be contained in the packaging fitments -Examine the packaging carefully before discarding. Check that all the items are present and undamaged.

3.2 Fireplace Flue Pull

Close all doors and windows in the room in which the appliance is to be installed. After confirming with a match that smoke is drawn into the flue, light a 13 gram smoke pellet and check that there is a definite flow through the flue. Verify outside that the smoke exits from one terminal only and that the termination is suitable. Observe, where possible, upstairs rooms and loft spaces for signs of escaping smoke indicating a defective flue. If there is not a definite flow warm the flue for a few minutes and repeat the smoke pellet test. If there is still no definite flow the flue may need remedial work – **Do not fit the appliance until there is a definite flow through the flue.**

3.3 Appliance Preparation

3.3.1. Stand the fire upright.

3.3.2. Remove the two transit screws from the upper back panel extensions. See figure 3A.

3.3.3. Detach the window surround. See figure 4:

- a) Remove the two knurled screws immediately below the outer case canopy.
- b) Lift the surround clear of the slots in the outer case apron

3.3.4. Remove the control knob by pulling clear of the gas tap spindle.

3.3.5. Remove the control bezel by

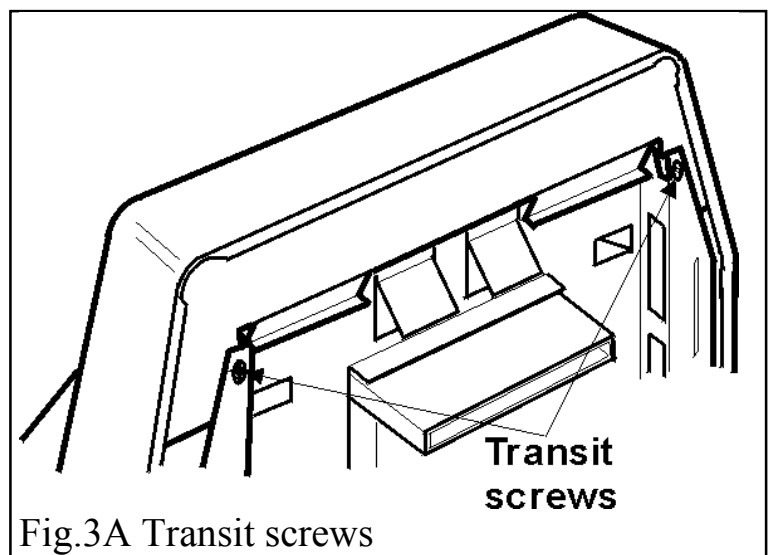

Fig.3A Transit screws

INSTALLER'S GUIDE

unscrewing two screws (see fig.5).

3.3.6. Detach the outer case by removing the screws at the case sides (see fig.5).

3.3.7. Pull the bottom of the case forwards while springing the bottom corners outwards to clear the fixing brackets. Lift the case upwards and forwards to clear (see

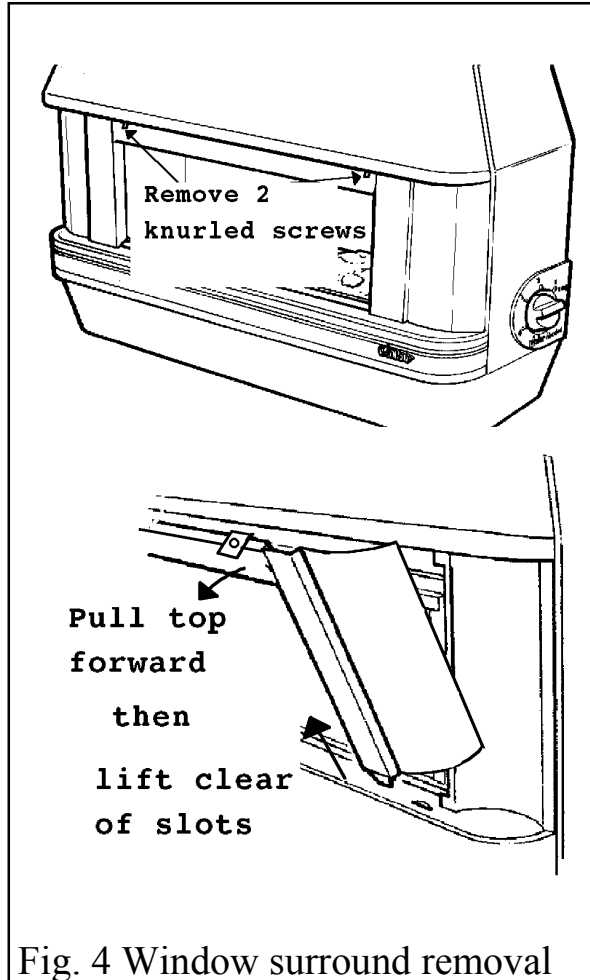
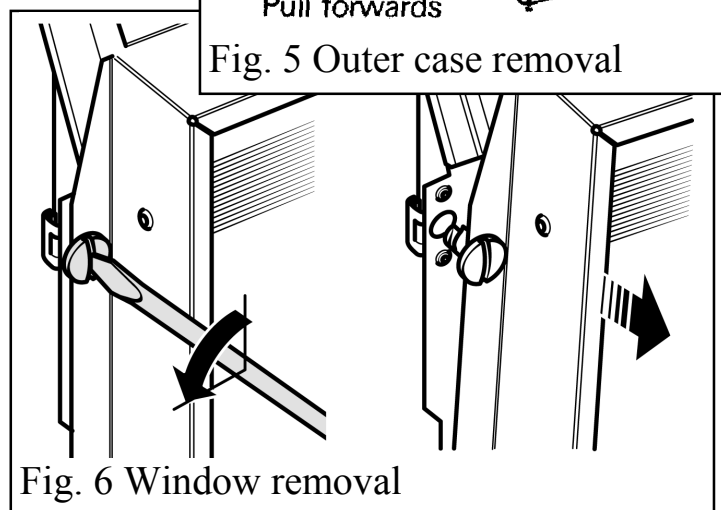
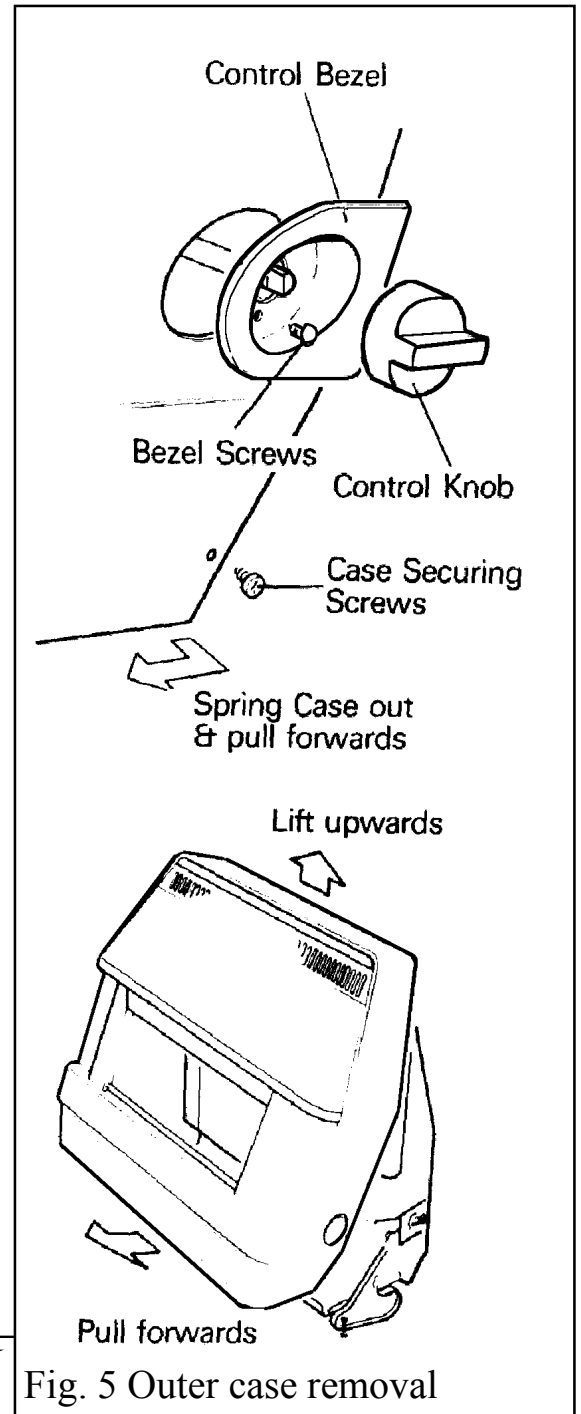

fig.5). Place carefully to one side.

3.3.8. Remove the window unit by turning the screws each side of the window frame $\frac{1}{4}$ turn anticlockwise and lifting the unit clear (see fig.6). *The flattened end of the smoke match tube can act as a screwdriver.*

3.3.9. Remove the coal pack from the firebox and keep it safe.

3.3.10. Check ignition spark
Before attempting to install, it is worth checking that the piezo electric spark ignition system operates satisfactorily. To initiate the spark, temporarily refit the control knob to the tap spindle. Depress the control knob and while keeping it depressed, turn anticlockwise through approximately 60° to the 1/IGN position. A spark should track from the electrode pin to pilot burner. If there is no spark or



INSTALLER'S GUIDE

incorrect tracking, check that the spark gap is between the limits shown in figure 7. If the spark gap is correct, check the ignition wiring.

Remove the control knob after checking.

3.3.11. For Wall Mounted Appliances

Remove the levelling screws and locknuts from below the feet.

3.3.12 If the fire is fitted to a recessed fireplace, an extension flue spigot up to a maximum total length of 125mm may be used. The extension must be a tight fit over the flue spigot and be secured by two self tapping screws. Note the minimum clearance required as shown in figure 2.

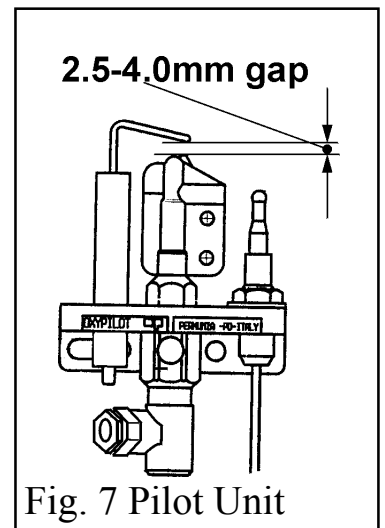

3.4 Fit The Closure Plate

See figure 8.

The closure plate has an opening at the bottom for a central gas feed pipe. The gap between the pipe and this opening should be sealed with tape after connection. If a central feed pipe is not required the opening should be completely sealed with tape.

3.4.1 Hearth mounting

See figure 9.

The closure plate must be fitted and sealed to the hearth and fireplace opening using a suitable heat resistant material. If necessary cut the closure plate but make sure that it overlaps the fireplace opening sufficiently to allow satisfactory sealing.

3.4.2 Wall mounting

See figure 10.

The closure plate must be fitted and sealed to the hearth and fireplace opening using a suitable heat resistant material. If necessary cut the closure plate but make sure that it overlaps the fireplace opening sufficiently to allow satisfactory sealing.

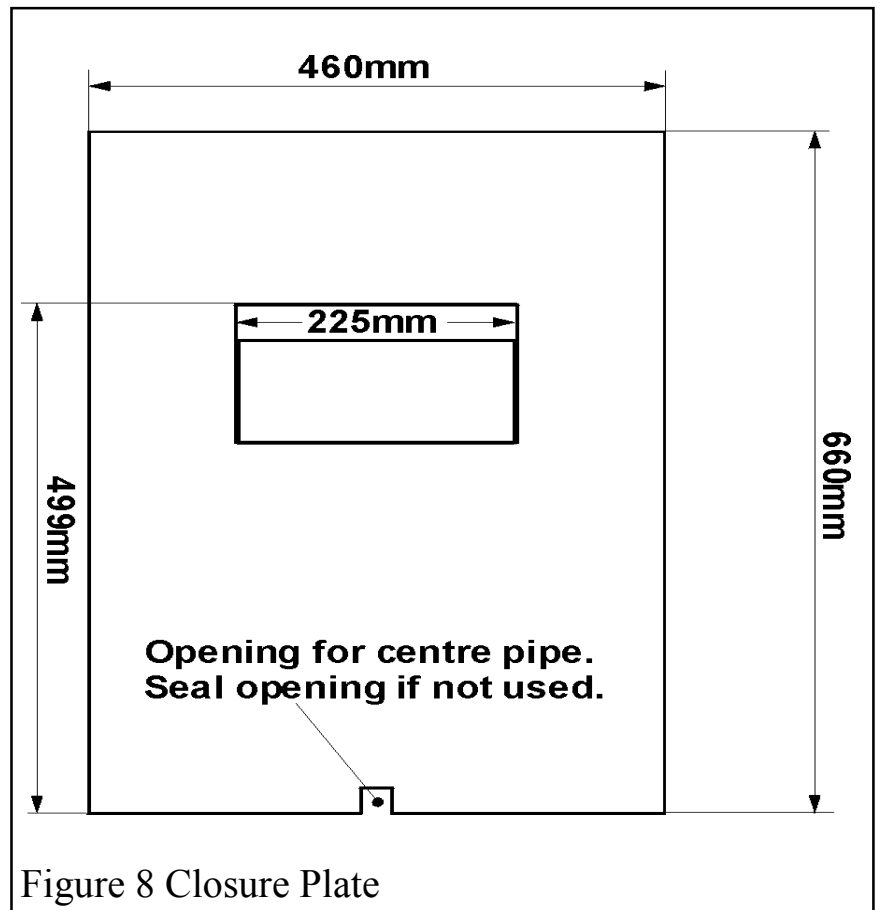

INSTALLER'S GUIDE

The bottom of the appliance must be at least 100mm above any carpet or other floor covering. To achieve this, the bottom of the flue spigot opening must be at least 565mm above the finished floor covering (See note **in section 2.9.4)

3.4.3 Check the flue pull with closure plate fitted by applying a lighted match or smoke match to the flue spigot opening in the closure plate and observe the smoke. If there is a definite flow continue with the installation. If not check the fitting of the closure plate. The fireplace flue pull check described in section 3.2 should have confirmed that the fireplace itself is satisfactory.

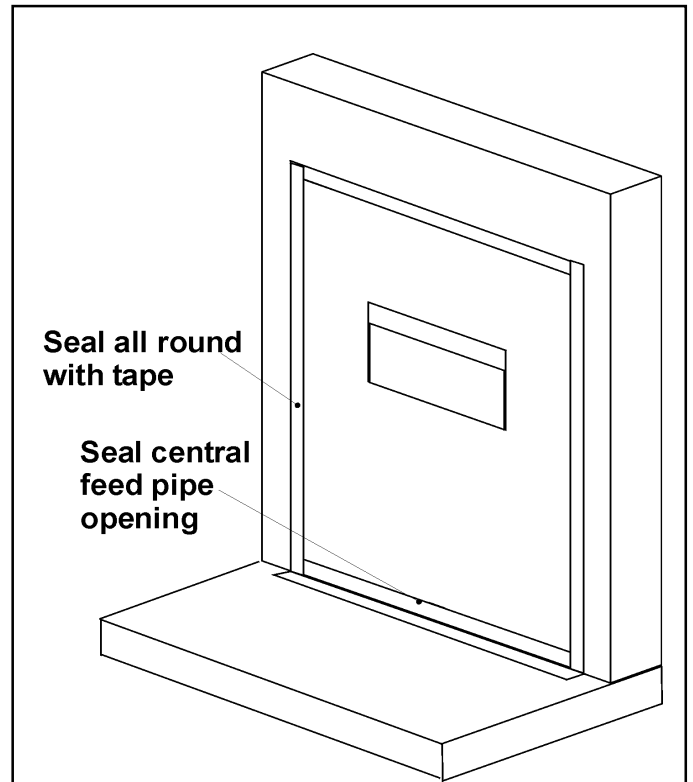

Figure 9 Closure Plate for Hearth Mounting

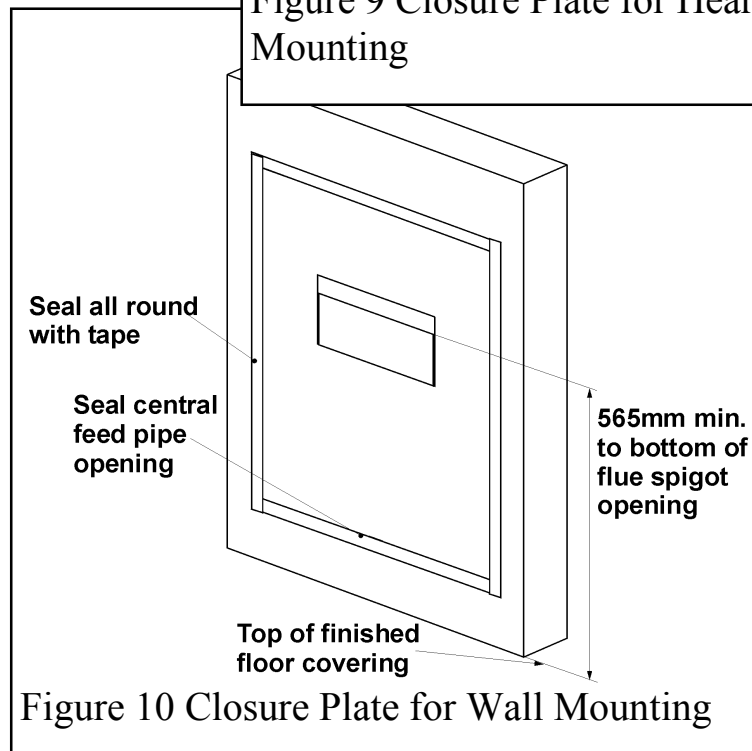

Figure 10 Closure Plate for Wall Mounting

4 APPLIANCE INSTALLATION

4.1 Installing To A Hearth

4.1.1 Place the fire centrally on the hearth making sure that the spigot lines up with the spigot hole in the closure plate. Gently slide the appliance into place. The spigot must enter the closure plate to a depth of at least 25mm.

4.1.2 Level the fire by loosening the lock nuts and turning the levelling screws in the feet up or down as required while they bear on the hearth. When the fire is level and square to the wall, retighten the lock nuts.

4.2 Wall Mounting

The fixing hole positions in relation to the flue spigot opening are shown in fig. 11. Mark these positions on the wall. The positions can alternatively be marked by placing the fire in position and marking the wall through the holes in the back panel.

Drill and plug the holes using no.10 wall plugs. Place the fire in position and secure with four no.10 x 2in. woodscrews.

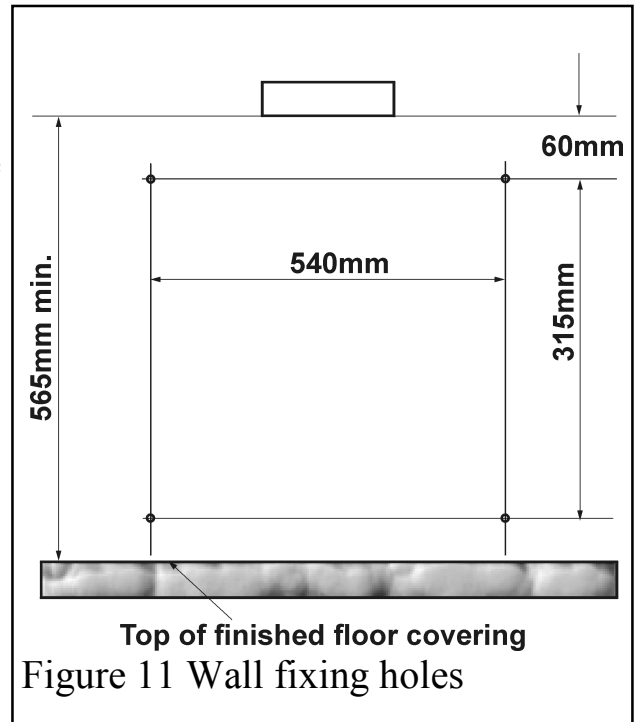

4.3 Gas Supply Connection

8mm rigid tubing must be used to connect the gas supply to the appliance. An olive and nut are provided for connection to the "T" connector on the appliance. The connector can be rotated to allow connection from either side or the rear. The connector includes a valve for isolating the gas supply.

The closure plate has a cut-out for rear connection. Seal the gap between the cut-out and the supply pipe.

Pressure check the installation pipework for gas soundness. In the United Kingdom check in accordance with the current edition of BS6891. In the Republic of Ireland check in accordance with the rules in force.

4.4 Fit the Coal and Window

4.4.1 Place the coal bed in position. Make sure that the coal

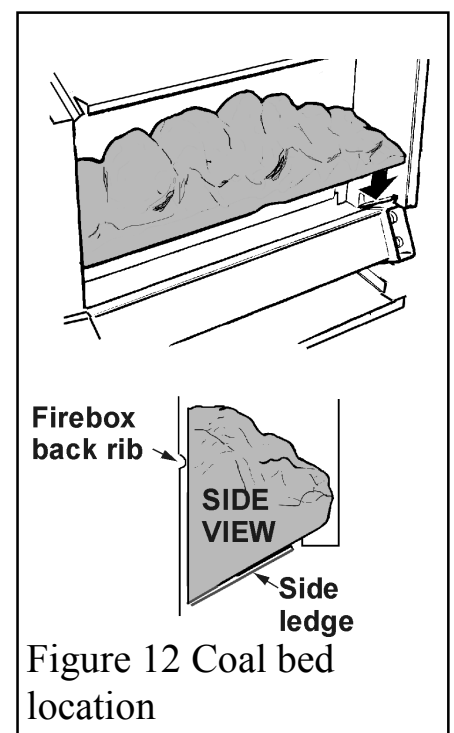

INSTALLER'S GUIDE

rests on the ledges at the sides of the firebox and that its back face is touching the horizontal rib at the back of the firebox. See fig.12.

4.4.2 Replace the window unit. Secure the window unit to the firebox by turning the two screws $\frac{1}{4}$ turn clockwise.

5 FULL OPERATING CHECKS

5.1 Check Control Settings

5.1.1 If closed, open the isolating valve at the inlet elbow.

5.1.2 To help in checking the control positions while the outer case is detached, place the control bezel over the gas tap spindle and against the tap bracket. Temporarily secure to the tap bracket with one of the screws.

5.1.3 Fit the control knob over the gas tap spindle.

5.1.4 Depress the control knob and turn anticlockwise partially towards the 1/IGN position until some resistance is felt. Keep depressed at this position to purge air from the system then, while keeping it depressed, turn fully to the 1/IGN position. A spark should be generated at the pilot while turning. The spark should ignite the pilot.

5.1.5 When pilot ignition has been achieved, keep the control knob depressed for approximately ten seconds to allow the thermocouple probe to warm up and then release it. If the pilot does not remain alight, ensure that the air has been purged, that the pilot orifice is clear and that the thermocouple connections are sound. Replace the pilot unit if necessary (see servicing section of this manual).

5.1.6 Check all the control settings. These are:-

<u>Knob Position</u>	<u>Burner appearance</u>
1/IGN	Centre section on low. Outer sections off.
2	Centre section fully on. Outer sections off.
3	Centre section fully on. Outer sections on low.
4	Centre and outer sections fully on.

5.2 Check Burner Pressure

The appliance is pre-set to give the correct heat input at the inlet pressure shown in section 1 of this manual. No adjustment is necessary. Check the burner pressure by fitting a pressure gauge at the test point. The test point is on the pipe connecting the gas tap to the lower injector. Check the pressure with the appliance alight and set at maximum output (Control position 4).

After checking, turn off the appliance. Remove the pressure gauge and replace the test point sealing screw. Relight the appliance. Turn to the maximum output position and test around the sealing screw for gas soundness with a suitable leak detection fluid.

If all the above checks are satisfactory, continue with the installation. If not, check the control and ignition circuitry and components as described in the servicing section of this manual.

INSTALLER'S GUIDE

5.3 Test For Spillage

A spillage test must be made before the installed appliance is left with the customer.

5.3.1 Close all doors and windows in the room containing the fire.

5.3.2 Light the appliance and set the control knob to the maximum position (Position 4).

5.3.3 Leave the appliance on for seven minutes.

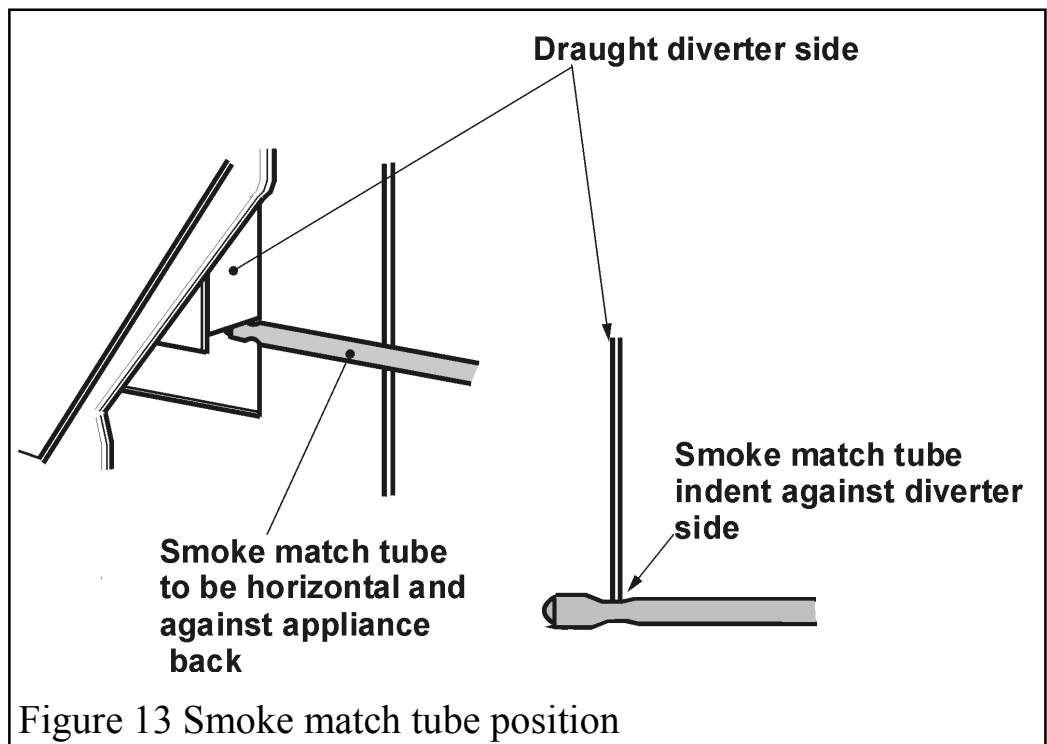

Figure 13 Smoke match tube position

5.3.4 Insert the smoke match tube (with lighted match) into the side of the appliance and against the back panel. Position the tube so that it is horizontal, against the back panel and with its top edge touching the side of the draught diverter box. Slide the tube until the indent in the tube is level with the diverter side. See figure 13.

5.3.5 The installation is satisfactory if the smoke is drawn into the diverter box. If an appreciable amount of smoke escapes from above the flue spigot or from the sides leave the appliance alight at the maximum setting for a further ten minutes and then repeat the test. **If the test is still unsatisfactory disconnect the appliance and seek expert advice.**

5.3.6 If the above test is satisfactory, open all internal connecting doors, hatches, etc. in the room. Keep all doors and windows that open to the outside of the building closed. recheck for spillage as above. If an extractor fan is installed in the same room as the appliance or a connecting room, check that spillage does not occur with the fan operating and all doors and other openings between the fan and the appliance open. If the test is satisfactory continue with the installation. **If the test is not satisfactory disconnect the appliance and advise the customer of the cause of failure.**

5.4 Flame Supervision & Spillage Monitoring System

The pilot unit incorporates a system which will automatically shut off the gas supply if the pilot flame goes out or if there is insufficient oxygen due to spillage or lack of ventilation.

Check that the system operates properly as follows;

5.4.1 Light the appliance. Set at position 4 and leave for one minute.

INSTALLER'S GUIDE

5.4.2 Turn back to “OFF” to extinguish the pilot. **Note the time when the pilot goes out.** Listen for a snap sound at the gas tap. **Note the time when the sound is heard.** This sound is caused by an electromagnetic valve shutting off the gas supply through the tap. The valve is located in the body of the tap. The valve should operate **within 60 seconds of the pilot going out.** If the valve does not operate within this time limit do not allow the appliance to be used until the fault has been corrected.

This monitoring system must not be adjusted, bypassed or put out of operation. This monitoring system, or any of its parts, must only be exchanged using Valor authorised parts.

6 FINAL ASSEMBLY & REVIEW

6.1 Fit The Outer Case

6.1.1 Detach the control knob and control bezel.

6.1.2 Refit the outer case. Make sure back of the outer case is located behind the main face of the engine back panel. The vertical side extensions of the back panel should project 10mm behind the back of the outer case. See figure 14.

6.1.3 Secure the case at the bottom sides with the two screws previously removed.

6.1.4 Place the control bezel back in position and secure it to the gas tap bracket with two screws.

6.1.5 Fit the control knob over the gas tap spindle.

6.1.6 Make sure that the coal is not dislodged when refitting the case.

6.1.7 Refit the window surround using the two knurled screws previously removed (The reverse method to that described in section 3.3.2). *Make sure that the outer edges of the surround sides are inside the outer case.*

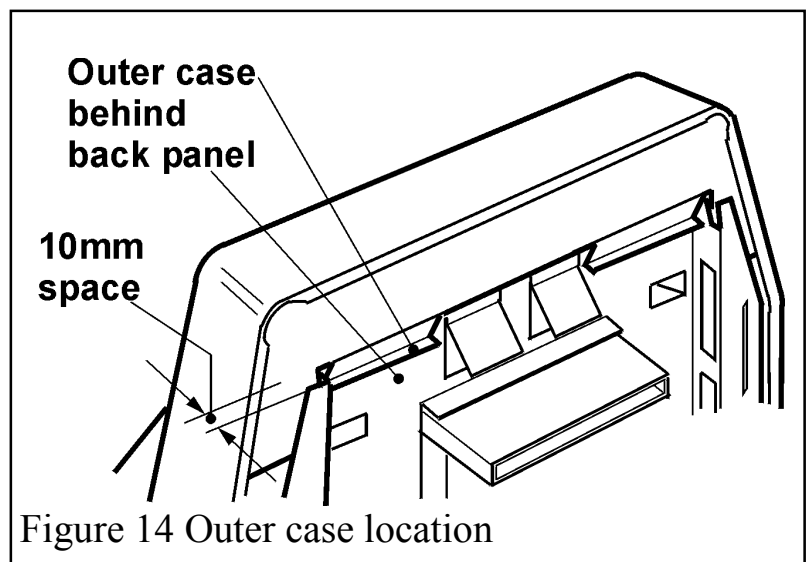

Figure 14 Outer case location

6.2 Final Review

6.2.1 Recheck the operation of the fire at all control positions.

6.2.2 Visually inspect the appliance. Clean off any marks incurred during installation.

6.2.3 Advise the customer how to operate the fire.

6.2.4 Explain to the customer that the appliance has a flame failure and spillage monitoring system. Point out the explanation of this system shown in the owner's guide.

INSTALLER'S GUIDE

Advise that if the fire goes out for any reason, wait at least three minutes before relighting.

Stress that if the monitoring system repeatedly shuts off the fire, the appliance should be switched off and a specialist should be consulted.

6.2.5 Advise the user that the window may require cleaning periodically outside and inside as described in the user's instructions. Explain how to remove and replace the window unit for cleaning the inside of the glass etc. Point out that the flattened end of the smoke match tube can act as a screwdriver for releasing the window screws. Leave the smoke match tube in the instruction pack.

6.2.6 Advise that the fire may give off a slight odour while new. This is quite normal and it will disappear after a short period of use.

6.2.7 Advise that any cleaning must only be carried out when the fire is off and cold.

6.2.8 Advise the customer that they should read the Owner's guide before operating the fire and always follow the advice in the section headed "Cleaning your fire".

6.2.9 Advise the customer that the appliance will operate to its maximum potential if the flue is primed during the first 20 – 30 minutes of use. To do this, simply turn the control to its highest setting. This will also burn off any carbon deposits that may have formed during previous use.

If using the appliance for long periods it is beneficial to change between settings. This will also help to remove any carbon deposits that may form during use.

6.2.10 Recommend that the appliance should be serviced and the chimney inspected by a competent person (In the UK a CORGI registered person) at least annually.

If the appliance is in premises in the United Kingdom occupied by a tenant, point out that by law a landlord must have any gas appliance, flue and pipework which is situated in a tenant's premises checked for safety at least every 12 months.

6.2.11 Hand the literature pack with this guide to the customer.

7 SERVICING & PARTS REPLACEMENT

- Always turn off the gas supply before commencing any servicing (The appliance inlet “T” connector incorporates an isolating valve).
- It is recommended that, at least once a year, the appliance is disconnected and the catchment space behind the closure plate checked and cleared of any debris. The closure plate must be resealed to the wall after checking.
- This product uses a fuel effect piece containing Refractory Ceramic Fibres (RCF), which are man-made vitreous silicate fibres. Excessive exposure to this material may cause temporary irritation to eyes, skin and respiratory tract. Consequently, it makes sense to take care when handling this article to ensure that the release of dust is kept to a minimum. To ensure that the release of fibres from this RCF article is kept to a minimum, during installation and servicing we recommend that you use a HEPA filtered vacuum to remove any dust and soot accumulated in and around the fire before and after working on the fire. When replacing this article we recommend that the replaced item is not broken up, but is sealed within a heavy duty polythene bag, clearly labelled as RCF waste. This is not classified as “hazardous waste” and may be disposed of at a tipping site licensed for the disposal of industrial waste. Protective clothing is not required when handling these articles, but we recommend you follow the normal hygiene rules of not smoking, eating or drinking in the work area and always wash your hands before eating or drinking.
- Check that soot or debris is not impairing the electrode spark or pilot burner.
- Check that soot or debris is not blocking any of the holes in the main burner.
- Always test for gas soundness and spillage after servicing the appliance.

7.1 To Remove Window Unit

7.1.1 Detach the window surround by removing the two knurled screws immediately below the outer case canopy and lifting the surround clear of the slots in the outer case apron (See figure 4 in installation section).

7.1.2 Remove the window unit by turning the screws each side of the window frame $\frac{1}{4}$ turn anticlockwise and lifting the unit clear (see figure 6 in the installation section).

7.1.3 Replace in the reverse order. Make sure that the coal is not dislodged when refitting.

7.2 To Remove Outer Case

See figure 5 in installation section.

7.2.1 Remove the control knob by pulling clear of the gas tap spindle.

7.2.2 Remove the control bezel by unscrewing two screws.

7.2.3 Detach the outer case by removing the screws at the case sides.

7.2.4 Pull the bottom of the case forwards while springing the bottom corners outwards to clear the fixing brackets. Lift the case upward and forwards to clear.

7.2.5 Replace in the reverse order. Make sure back of the outer case is located behind the main face of the engine back panel. The vertical side extensions of the back panel should project 10mm behind the back of the outer case. See figure 14 in the installation section. Make sure that the coal is not dislodged when refitting the case.

7.3 To Remove The Coal

7.3.1 Remove the window unit as described in section 7.1

7.3.2 Remove the coal.

7.2.3 Replace in the reverse order. When replacing, make sure that the coal rests on the ledges at the sides of the firebox and that its back face is touching the horizontal rib at the back of the firebox. See figure 12 in the installation section.

7.4 To Remove The Gas Tap

7.4.1 Remove the outer case as section 7.2 above.

7.4.2 Detach the electrode lead from the pilot unit by pulling the lead down and away from the electrode situated at the centre rear of the burner.

7.4.3 Disconnect the two pipes linking the upper and lower injectors at the tap end and loosen their connections at the injector ends. Swing the pipes clear of the tap.

7.4.4 Disconnect the inlet pipe and pilot pipe from the gas tap.

7.4.5 Remove the locknut holding the gas tap to the tap bracket.

7.4.6 Carefully lift the tap clear to allow access to the thermocouple connection. Disconnect the thermocouple from the tap.

7.4.7 Replace in the reverse order.

7.5 To Remove The Piezo Generator

7.5.1 Remove the gas tap as section 7.4.

7.5.2 Make sure that the tap is in the off position.

7.5.3 Remove the circlip holding the piezo unit to the tap. Remove the piezo unit.

7.5.4 Replace in the reverse order.

7.6 To Grease The Control Tap

7.6.1 Detach the tap and remove the piezo generator as section 7.5 making sure that the tap is in the off position.

7.6.2 Remove the two screws from the head of the tap. Remove the nutting head and spindle complete with collar and spring.

7.6.3 Note the position of the slot in the plug - mark its position on the tap body.

7.6.4 Remove the plug rotating slightly while pulling.

INSTALLER'S GUIDE

7.6.5 Clean and grease the plug lightly with suitable grease. Do not apply excessive grease. Particularly, make sure that the gas ports in the tap are not restricted by grease.

7.6.6 Push the plug into the tap body and position the slot in line with the mark previously made on the tap body.

7.6.7 Reassemble the nutting head and spindle complete with collar and spring making sure that the components are correctly engaged. Check the operation of the tap.

7.6.8 Refit the piezo generator.

7.7 To Remove An Injector

7.7.1 Remove the outer case as section 7.2.

7.7.2 Release the pipe compression fitting to the upper or lower injector as required. Lock the injector with a second spanner to ensure that it does not move.

7.7.3 Loosen the pipe compression fitting at the tap end and move the pipe clear.

7.7.4 Remove the injector from the burner.

7.7.5 Replace in the reverse order.

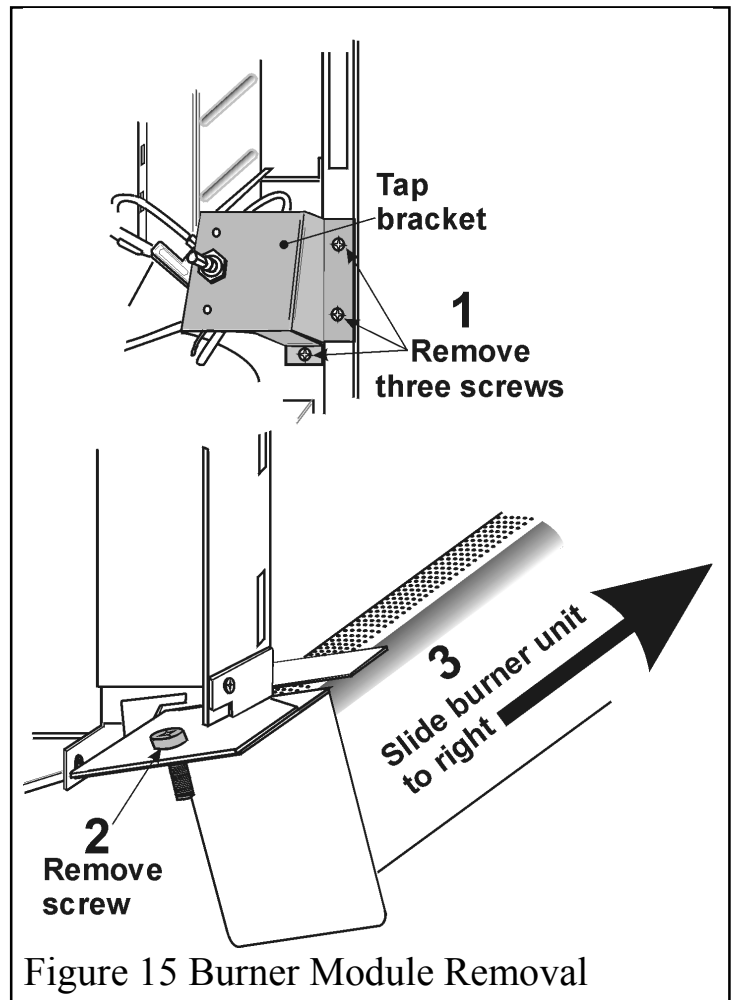

Figure 15 Burner Module Removal

7.8 To Remove The Complete Burner Module, Pipes and Pilot

7.8.1 Remove the outer case as section 7.2.

7.8.2 Remove the coal as section 7.3.

7.8.3 Support the inlet isolating elbow to avoid straining the pipework and disconnect the appliance from the elbow.

7.8.4 Detach the gas tap bracket from the right side of the appliance by removing three screws. See figure 15.

7.8.5 Detach the left side of the burner from the firebox by removing one screw. See figure 15.

7.8.6 Free the burner & pilot module from the rear pilot air pipe and the firebox by carefully sliding the module to the right while pulling it slightly. See figures 15 and 16.

7.8.7 Remove the pipes, or pilot unit if required.

7.8.8 Replace in the reverse order.

INSTALLER'S GUIDE

- Note: 1. The pilot unit is an atmosphere sensing device. It must be replaced as a whole assembly. Its individual components are not separately replaceable.*
- 2. If the pilot is removed, when refitting, make sure that the pilot heat shield is in place between the pilot unit and the rear of the burner and is the correct way round. See figure 16.*
- 3. Check that there is no blockage of the air intake tube at the back of the pilot unit. Make sure that the air intake tube locates fully into the pilot air pipe attached to the back panel. See figure 16.*

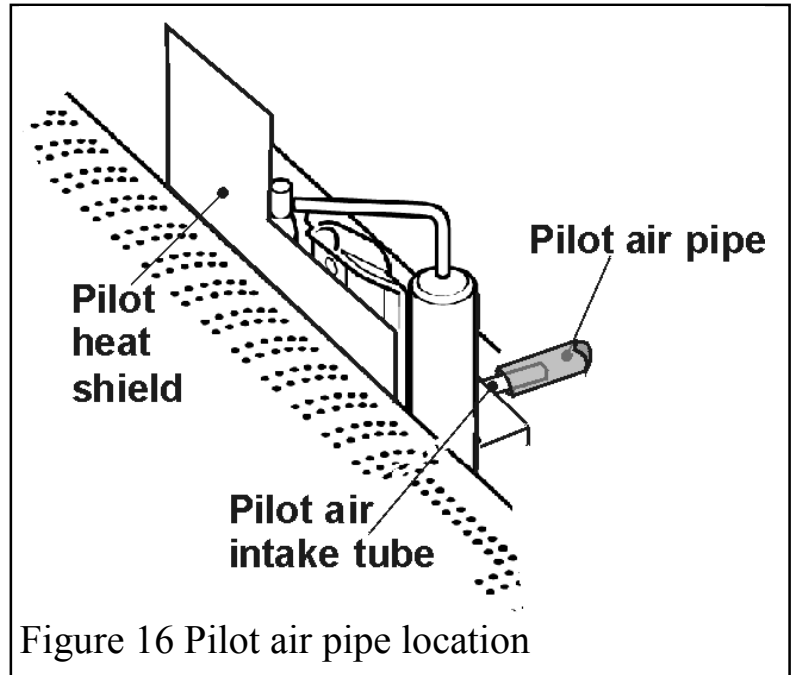
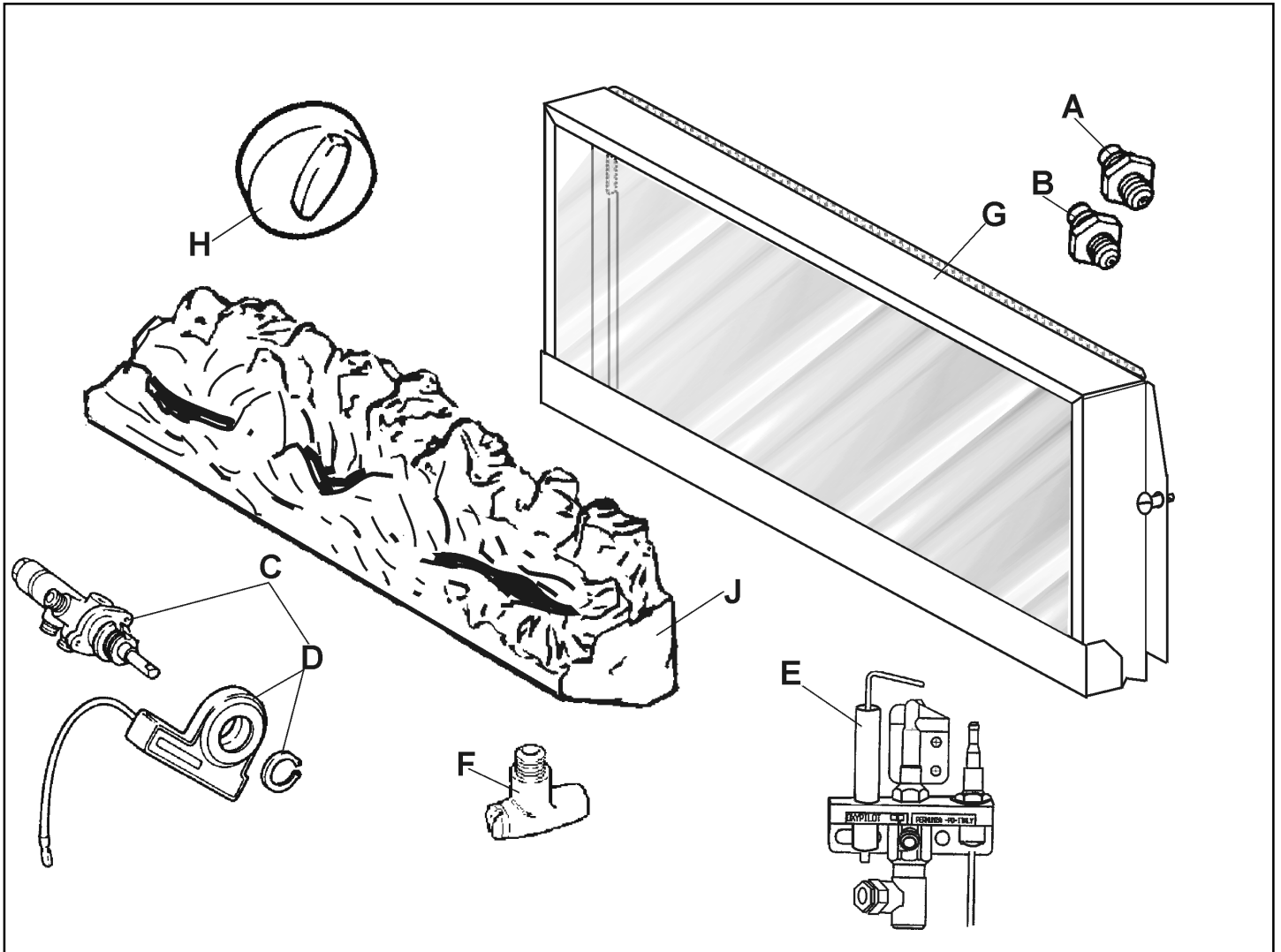

Figure 16 Pilot air pipe location

INSTALLER'S GUIDE

8 REPLACEMENT PARTS – SHORT LIST



KEY	DESCRIPTION	No. OFF	PART No.
A	Upper Injector Bray Cat. 99 Size 115	1	0579009
B	Lower Injector Bray Cat. 99 Size 230A	1	0579019
C	Gas Tap & Spark Generator	1	0558799
D	Spark Generator	1	0521069
E	Pilot Unit	1	0579029
F	Inlet & Isolating "T" Connector	1	0541029
G	Window Unit	1	0579039
H	Control Knob	1	0520799
J	Coal	1	0579049