



OWNER'S GUIDE

HEARTBEAT

OXYSAFE 2

MODEL 339

(GC No. 32-032-29)

LIVE FUEL EFFECT

GAS FIRE



**THIS APPLIANCE IS FOR USE WITH NATURAL GAS (G20)
THIS APPLIANCE IS FOR USE IN THE UNITED KINGDOM (GB) AND THE
REPUBLIC OF IRELAND (IE) ONLY.**

This guide is intended to help you care for your Valor gas fire. Please read thoroughly before using and keep for future reference

We trust that this guide gives sufficient details to enable the your appliance to be operated and maintained satisfactorily. However, if further information is required, our **Valor Technical Helpline** will be pleased to help.
Please telephone **08706 061 065** (National call rates apply).

This guide to be left with the owner

OWNER'S GUIDE

Safety First.

Valor fires are CE Approved and designed to meet the appropriate British Standards and Safety Marks.



Quality and Excellence at the heart of every Valor fire.

All Valor fires are manufactured to the highest standards of quality and excellence and are manufactured under a BS EN ISO 9001 quality system accepted by the British Standards Institute.



The Highest Standards

Valor is a member of the Society of British Gas Industries which works to ensure high standards of safety, quality and performance.



Careful Installation

Valor is a CORGI registered company. All our gas fires must be installed by a competent CORGI Registered Installer in accordance with our Installer Guide and should not be fitted directly on to a carpet or floor of combustible material.



Valor Heating, Erdington, Birmingham B24 9QP
www.valor.co.uk

Because our policy is one of constant development and improvement, details may vary slightly from those given in this publication

OWNER'S GUIDE

LIST OF CONTENTS

SAFETY	3
APPLIANCE DIMENSIONS.....	5
OPERATING YOUR FIRE	6
CLEANING	8
MAINTENANCE	10

C U S T O M E R C A R E

Thank you for choosing Valor.

All Valor gas fires are designed to meet the most stringent quality, performance and safety requirements to provide our customers with many years' trouble-free service.

Your owner guide aims to improve your understanding and appreciation of your Valor gas fire by providing simple and informative instructions to ensure that you benefit from the excellent performance and features it has to offer.

If you require further assistance or any advice about gas in general, the **Valor Technical Helpline** will be pleased to help.

Please telephone **08706 061 065** (National call rates apply in the United Kingdom).

SAFETY

IF YOU SMELL GAS

DON'T SMOKE

EXTINGUISH ALL NAKED FLAMES

DON'T TURN ELECTRICAL SWITCHES ON OR OFF

TURN OFF THE GAS SUPPLY AT THE METER

OPEN DOORS AND WINDOWS TO GET RID OF THE GAS

IMMEDIATELY CALL THE GAS EMERGENCY SERVICE – SEE YOUR LOCAL TELEPHONE DIRECTORY

OWNER'S GUIDE

DO

- Have the fire installed by a competent person. In the United Kingdom, installation must be in accordance with the latest edition of the Gas Safety (installation & use) Regulations. In the Republic of Ireland, installation must be in accordance with all national and local regulations in force.
- Have the chimney swept prior to installation if it was previously used for solid fuel.
- Have the fire installed in accordance with the installation instructions

- Provide a minimum clearance as shown in graph 1 above the top of the outer case to any shelf made of wood or other combustible material.
- Provide a suitable guard which complies with BS 6539 or

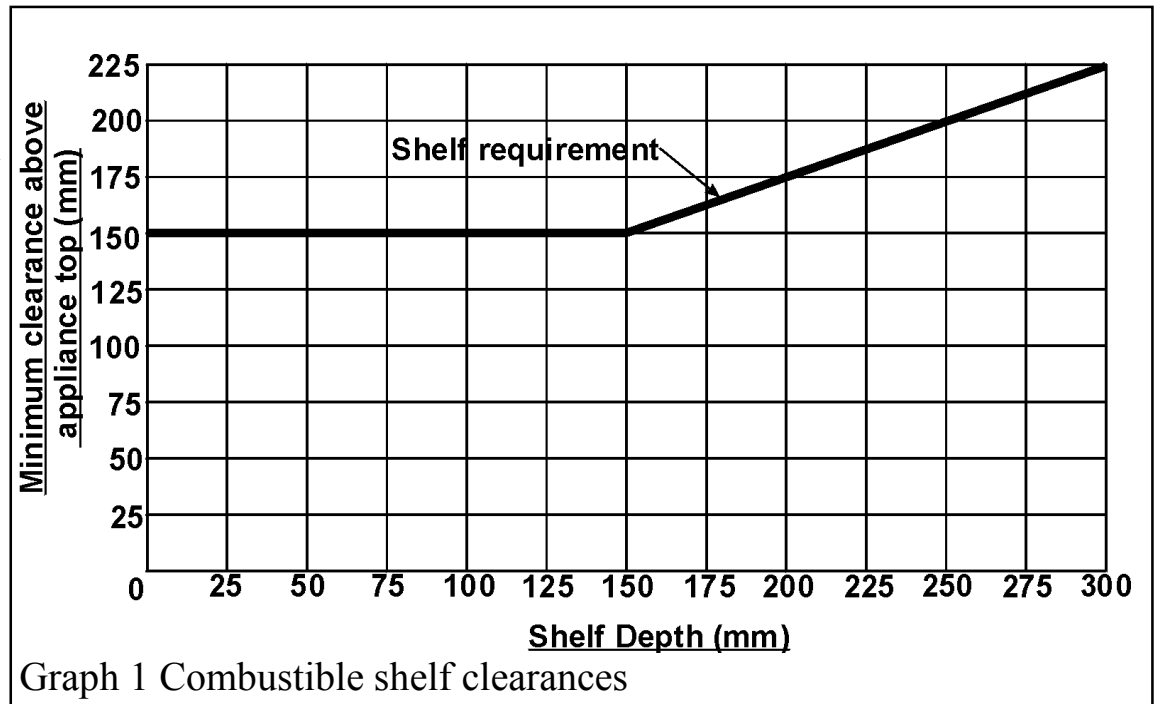

6778 for the protection of young children, the elderly and the infirm. Such a guard is also recommended for the protection of pet animals. (Although this fire conforms to all the applicable standards, it is a heating appliance and certain parts of its surface will become hot.)

The glass panel & apron together act as a fireguard conforming to BS1945:1971 and satisfy the Heating Appliance (Fireguard) (Safety) Regulations 1991.

- Wait three minutes before attempting to relight if the fire is switched off or the flames are extinguished for any reason. (Your fire is fitted with a safety device that will automatically shut off the gas supply to the fire if, for any reason, the flames go out.)
- Get advice about the suitability of any wall covering near your fire. Soft wall coverings (e.g. embossed vinyl, etc.) which have a raised pattern, are easily affected by heat. They may, therefore, scorch or become discoloured when close to a heating appliance. Please bear this in mind whenever you are considering redecorating.
- Provide a minimum side clearance as detailed in figure 1. Please bear this in mind if ever you are considering altering the room.

OWNER'S GUIDE

DON'T

- Hang clothing, towels or any other fabrics over the fire.
- Fill in the space behind the case.
- Use the fire with a damaged coal piece or with the coal incorrectly positioned.
- Use the fire if the glass window is damaged.
- Allow any combustible material (e.g. Wallpaper, plastic tiling, wood panelling etc.) on the fireplace wall below the shelf.
- Attempt to clean or service the fire until it has been switched off and allowed to cool completely.

APPLIANCE DIMENSIONS

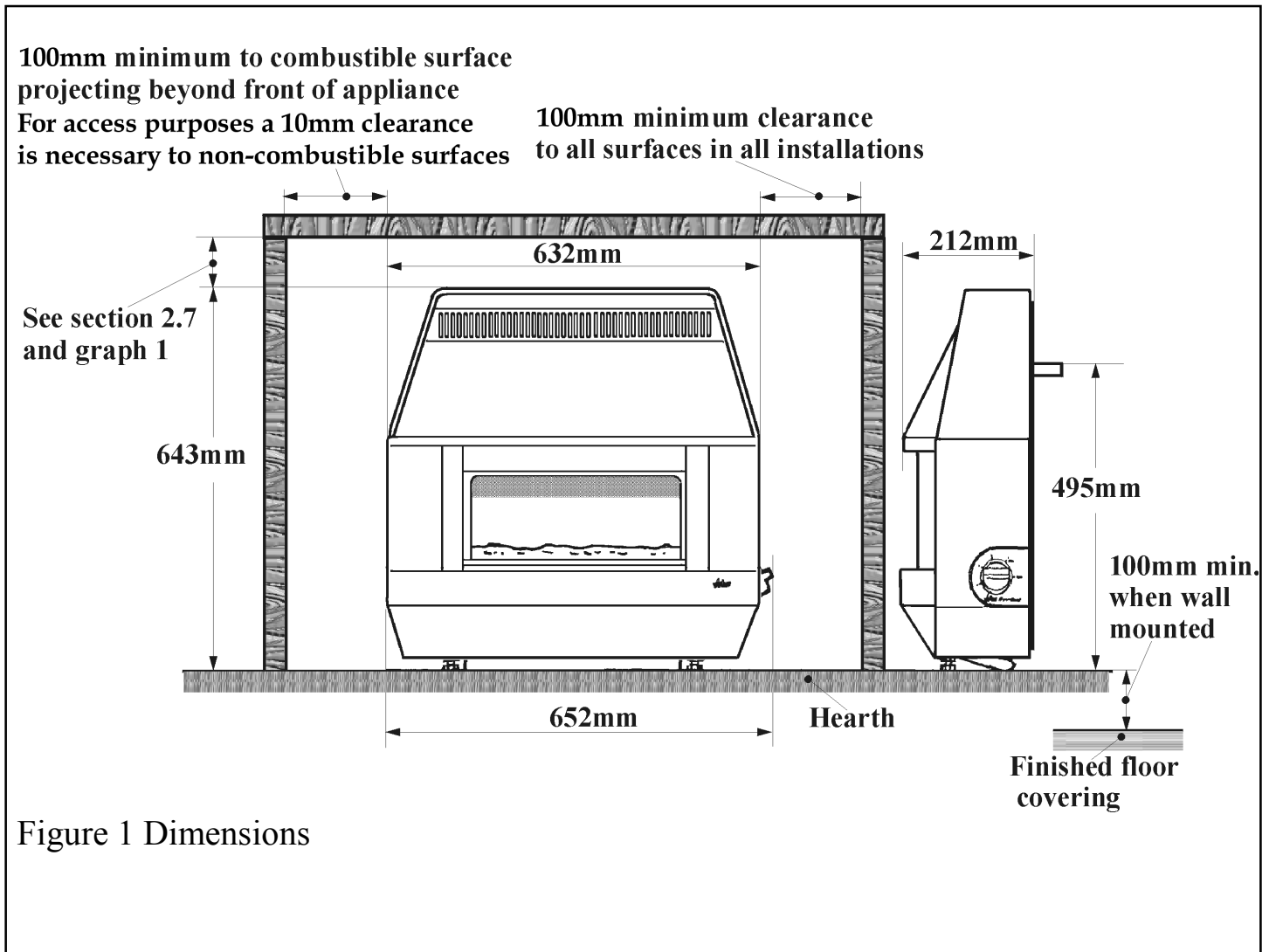

OWNER'S GUIDE

OPERATING YOUR FIRE

PLEASE NOTE

When operating your fire for the first time, some vapours may be given off which may cause a slight odour and could possibly set off any smoke alarms in the immediate vicinity. These vapours are quite normal with new appliances. They are totally harmless and will disappear after a few hours use.

The Oxysafe flame sensing & flue blockage safety system.

For your safety, this appliance is fitted with a flue blockage safety device which will shut down the appliance in the event of abnormal flue conditions. ***This device is NOT a substitute for an independently mounted Carbon Monoxide detector.***

The device will also automatically shut off the gas supply to the fire if the pilot flame goes out due to lack of oxygen or for any other reason.

If this device starts to repeatedly shut off the gas, get expert advice.

This device incorporates a probe which senses that the heat from the pilot flame is correct. If this probe is cool, the device will prevent any gas flow unless the control knob is held in at the ignition position.

If, for any reason, the flames go out when the fire is hot or if the fire is turned off when hot, always ***wait at least three minutes before attempting to relight.***

To light the fire

The control is shown in Figure 2.

- Depress the control knob and turn partially to the 1/IGN position until you feel some resistance.
- Keep the knob depressed at this position for a few seconds to allow gas to flow to the burner.
- While keeping the knob depressed, turn to the 1/IGN position. While turning, a spark should light the pilot.
- Keep the knob depressed at the 1/IGN position for a further 10 seconds then release it. The centre section of the coal will be alight at this position.
- Depress the control knob slightly and turn it to your desired burner setting.
- The control knob should be depressed slightly before turning whenever you are changing the burner setting.

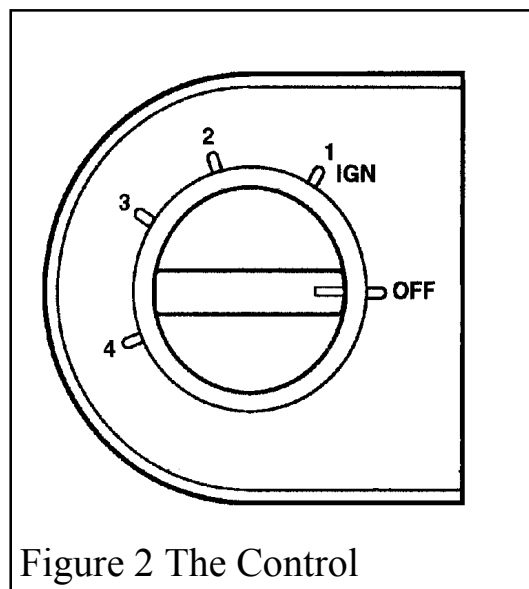

Figure 2 The Control

OWNER'S GUIDE

- The burner settings are;
1/IGN.....Centre section on low. Outer sections off.
2.....Centre section fully on. Outer sections off.
3.....Centre section fully on. Outer sections on low.
4.....Centre section fully on. Outer sections fully on.
- We recommend that the fire is set at position 4 for the first 10 minutes after lighting to warm up the chimney and so obtain full efficiency quickly.
- If operating the appliance for long periods it is beneficial occasionally to change the settings. This will also help to remove any carbon deposits that may form during operation.

Note: If the fire goes out while setting the control, repeat the full lighting procedure. If the fire repeatedly goes out, have the fire serviced.

To turn the fire off

- Partially depress the control knob and turn clockwise to OFF. Release the knob.
- Wait at least 3 minutes after turning the fire off before relighting.

Lighting with a taper

In the unlikely event of failure of the ignition spark, the pilot can be lit with a taper or long spill after the window surround and window unit have been removed. Removal of these parts is described in the “Cleaning Window Glass” chapter on the next page.

Insert the taper or spill into the centre opening in the ceramic coal while the control is kept depressed at the 1/IGN position. See figure 3.

When the pilot has lit follow the rest of the instructions in the instructions headed “To light the fire”. **Always replace the window unit after lighting.**

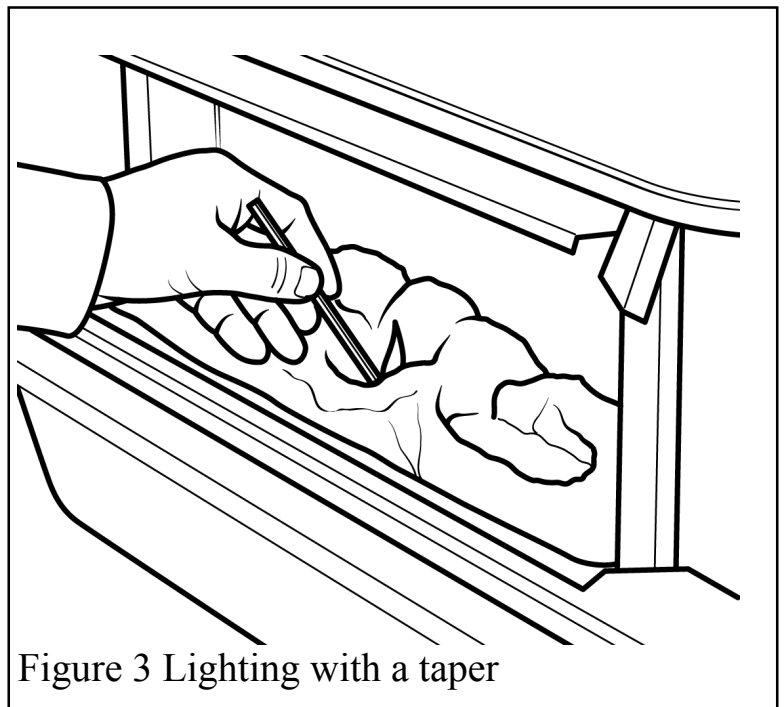

Figure 3 Lighting with a taper

CLEANING

To maintain the high performance and quality finish of your Valor fire, please follow these guidelines:

- Before attempting to clean the fire, please remember to turn off the fire and wait for the appliance to cool. The fire will retain heat for some time before cleaning can begin.
- If any pieces of debris are found in the fire box, have the chimney inspected before further use.

Metal Parts

- Clean the metal parts with a slightly damp cloth and then dry.
- Do not use abrasive cleaners as these will scratch the fire surface.

Window Glass

- Remove any stains on the window with a non-abrasive cleaner such as a ceramic hob cleaner. Do not use abrasive cleaners.
- The fire has been designed so that you can remove the window without having to call in a service engineer. This allows you to clean the inside of the window.

To remove the window:

1. Unscrew and remove the two knurled screws which are under the outer case canopy. See figure 4.
2. Pull the top of the window surround forward. See figure 4.
3. Lift the window surround up to clear the slots in the case apron. See figure 4. Put the surround in a safe place.

4. Remove the window unit by turning the screws each side of the window frame $\frac{1}{4}$ turn anticlockwise. A screwdriver is provided with your fire for turning the screws. Lift the window unit clear. See figure 5.

5. After cleaning, replace and secure the window unit to the firebox by turning the two screws $\frac{1}{4}$ turn clockwise with the screwdriver. Replace the surround. Make sure that the outside edges of the window surround sides are inside the outer case.

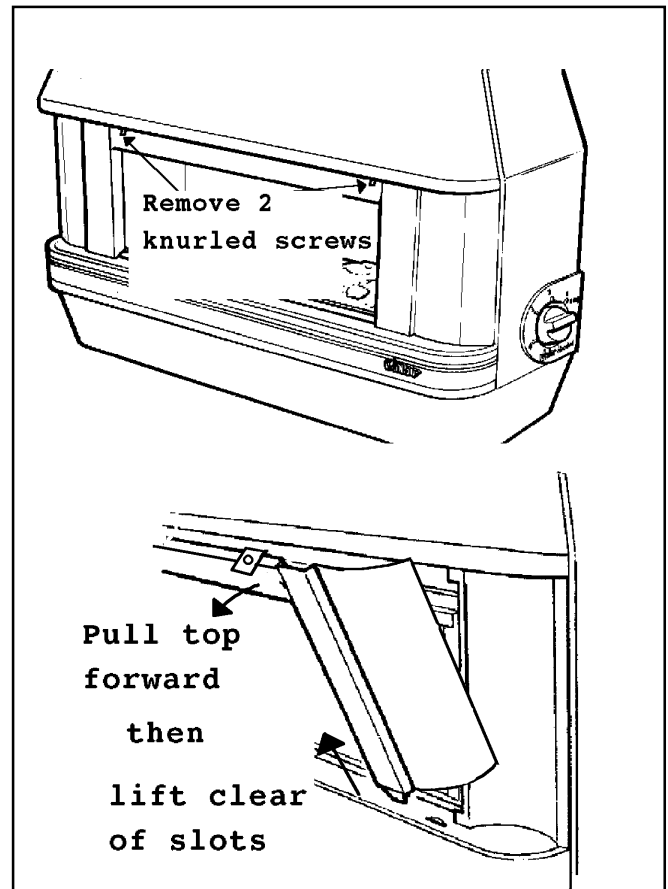
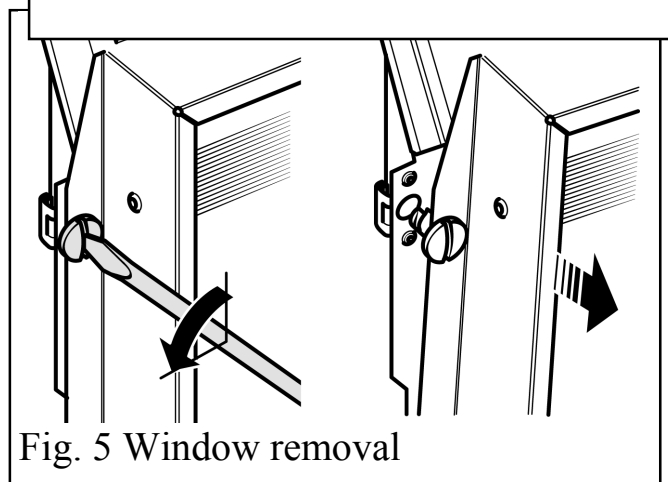

Fig. 4 Window surround removal



OWNER'S GUIDE

Ceramic Coal

- This product uses a fuel effect piece containing Refractory Ceramic Fibres (RCF), which are man-made vitreous silicate fibres. Excessive exposure to this material may cause temporary irritation to eyes, skin and respiratory tract. Consequently, it makes sense to take care when handling this article to ensure that the release of dust is kept to a minimum.
- Although light coatings of soot are usually burnt off during normal use, the coal may benefit from occasional cleaning.
- Should any soot accumulation become excessive, the fuel effect piece should be removed from the fire for cleaning. Cleaning should be carried out in a well ventilated area or in the open air by gently brushing with the pieces held away from your face so that you avoid inhaling the dust. We do not recommend the use of a normal domestic vacuum cleaner which may blow dust back into the air.
- The coal can be lifted out of the fire box when the window surround and glass have been removed as described on page 8.
- When replacing the coal, make sure that it rests on the ledges at the sides of the firebox and that its back face is touching the horizontal rib at the back of the firebox. See figure 6.
- Replace the window and surround after cleaning.
 - Make sure that the outside edges of the window surround sides are inside the outer case.

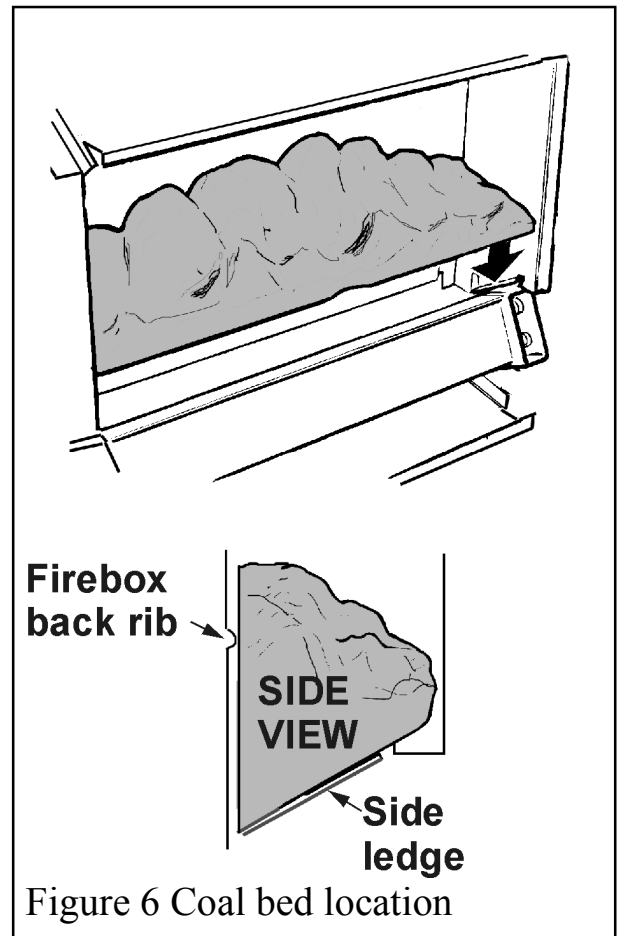

Figure 6 Coal bed location

OWNER'S GUIDE

MAINTENANCE

Regular maintenance

In order to achieve and maintain high levels of personal safety and performance efficiency, it is essential that the opening at the back of the fire and the flue are kept clear of any form of obstruction. It is possible that deposits of mortar or soot could fall and accumulate causing the flue to be blocked or restricted and so preventing proper clearance of dangerous exhaust fumes.

In the United Kingdom it is the law that a landlord must have any gas appliance, flue and pipework which is situated in a tenant's premises checked for safety at least every twelve months by a competent person (In the U.K, a CORGI registered installer).

We recommend that all gas appliances and their flues, wherever situated, are checked annually.

Servicing

- In the United Kingdom servicing can be carried out either by a Valor Service engineer or a CORGI registered installer.
- If you require your fire to be serviced, please contact **Valor Service** on **08706 090 081** and quote the following details;
 - a) model name and number.
 - b) appliance serial no. (To be found on a label near the bottom of the right side of the case.)
- If you wish to replace any of the owner replaceable parts listed below, please contact **Valor Spares** on **08706 000 454** for your nearest stockist of these parts. When ordering please quote the part number shown below.

Owner Replaceable Parts

<u>Description</u>	<u>Part No</u>
Ceramic coal	0579049
Window unit	0579039
Window surround	0579069
Knurled screw for window surround	0558839

- **When fitting replacement parts, follow the instructions contained in this guide. It is important that only Valor approved parts are used for maximum safety.**
- In the United Kingdom, for general advice about gas and your gas fire call the **VALOR TECHNICAL HELPLINE 08706 061 065.**
- In the Republic of Ireland call **0044 08706 061 065** for all enquiries.