

BAXI FIRES DIVISION

INSTALLER GUIDE

Model 347

Radiant / Convector Gas Fire

Fitted with one of the following fascia

Brava 4 Oxysafe,
Charm 4 Oxysafe,

or

Esquire 4 Oxysafe

(G. C. Number 32-032-62)



**THIS APPLIANCE IS FOR USE WITH NATURAL GAS (G20)
THIS APPLIANCE IS SUITABLE ONLY FOR INSTALLATION IN THE UNITED
KINGDOM (GB) AND THE REPUBLIC OF IRELAND (IE) ONLY.**

We trust that this guide gives sufficient details to enable the appliance to be installed and maintained satisfactorily. However, if further information is required, our

Baxi Fires Division Technical Helpline will be pleased to help.

Please telephone 08706 061 065 (National call rates apply in the United Kingdom). In the Republic of Ireland telephone **0044 8706 061 065**.

INSTALLER: Please leave this guide with the owner

INSTALLER GUIDE

Safety First.

Baxi Fires Division fires are CE Approved and designed to meet the appropriate British Standards and Safety Marks.



Quality and Excellence.

At the heart of every Baxi Fires Division fire.

All Baxi Fires Division fires are manufactured to the highest standards of quality and excellence and are manufactured under a BS EN ISO 9001 quality system accepted by the British Standards Institute.



The Highest Standards

Baxi Fires Division is a member of the Society of British Gas Industries which works to ensure high standards of safety, quality and performance.



Careful Installation

Baxi Fires Division is a CORGI registered company. All our gas fires must be installed by a competent CORGI Registered Installer in accordance with our Installer Guide and should not be fitted directly on to a carpet or floor of combustible material.

B A X I F I R E S D I V I S I O N

Baxi Fires Division, Erdington, Birmingham B24 9QP
www.firesandstoves.co.uk

Because our policy is one of constant development and improvement, details may vary slightly from those given in this publication

INSTALLER GUIDE

CONTENTS

<u>Section</u>	<u>Heading</u>	<u>Page</u>
1	SAFETY	4
2	LIST OF ACCESSORIES	4
3	APPLIANCE DATA	5
4	GENERAL INSTALLATION REQUIREMENTS	5
5	PRE-INSTALLATION PREPARATION	13
	5.1 Unpacking.	13
	5.2 Fireplace flue pull.	13
	5.3 Appliance preparation.	13
	5.4 Fitting the battery to electronic ignition models.	14
	5.5 Checking the ignition.	14
	5.5.1 Manual ignition.	14
	5.5.2 Electronic ignition.	14
	5.6 Fitting the closure plate.	14
6	APPLIANCE INSTALLATION	17
	6.1 Using the extension brackets.	17
	6.2 Installing to a hearth.	17
	6.3 Wall mounting.	18
	6.4 Gas supply connection.	18
	6.5 Radiants installation.	18
	6.6 Flue restrictor adjustment.	18
7	CONTROL & PRESSURE CHECKS	19
	7.1 Check control settings.	19
	7.2 Flame supervision and spillage monitoring system.	20
	7.3 Check reference pressure.	20
8	FASCIA FITTING	21
9	SPILLAGE CHECK	22
10	FINAL REVIEW	23
11	SERVICING & PARTS REPLACEMENT	24
	11.1 To remove the fascia.	24
	11.2 To replace radiant(s).	24
	11.3 To replace the pilot unit.	24
	11.4 To remove the piezo generator (manual ignition models).	25
	11.5 Note for electronic ignition.	25
	11.6 To remove the complete burner module, pipes and pilot.	25
	11.7 To grease the gas tap	26

INSTALLER GUIDE

1 SAFETY

Installer

Before continuing any further with the installation of this appliance please read the following guide to manual handling.

- The lifting weight of this appliance is as below:

<u>Model</u>	<u>Heat Engine (kg)</u>	<u>Fascia (kg)</u>
Brava	10.15	7.39
Charm	10.15	7.39
Esquire	10.15	5.64

- One person should be sufficient to lift the fire. If for any reason this weight is considered too heavy then obtain assistance.
- When lifting always keep your back straight. Bend your legs and not your back.
- Avoid twisting at the waist. It is better to reposition your feet.
- Avoid upper body/top heavy bending. Do not lean forward or sideways whilst handling the fire.
- Always grip with the palm of the hand. Do not use the tips of fingers for support.
- Always keep the fire as close to the body as possible. This will minimise the cantilever action.
- Use gloves to provide additional grip.
- Always use assistance if required.

2 LIST OF ACCESSORIES

Description	Part number
Spigot extension	0595191

INSTALLER GUIDE

3 APPLIANCE DATA

This appliance does not contain any component manufactured from asbestos or asbestos related products.

The appliance data label is on the inner face of the back panel at the lower left hand side. It is visible when the fascia is removed.

Gas		Natural (G20)
Inlet Pressure		20mbar
Gross Heat Input	Max.	5.6kW (19,107Btu/h)
	Min.	1.57kW (5,357Btu/h)
Burner Test Pressure (Cold)		17.95±0.75mbar (7.2±0.3in w.g.)
Gas Connection		8mm pipe
Burner Injectors	Upper (Centre Radiants)	Bray Cat. 28 Size 185
	Lower (Outer Radiants)	Bray Cat. 28 Size 185
Pilot & Atmosphere Sensing Device		OPNG9093
Ignition		Twin spark Piezo-electric, integral with gas tap
Aeration		Non-adjustable

4 GENERAL INSTALLATION REQUIREMENTS

4.1 The installation must be in accordance with these instructions.

For the user's protection, in the United Kingdom it is the law that all gas appliances are installed by competent persons in accordance with the current edition of the Gas Safety (Installation and Use) Regulations. Failure to install the appliance correctly could lead to prosecution. The Council for the Registration of Gas Installers (CORGI) requires its members to work to recognised standards.

In the United Kingdom the installation must also be in accordance with:

- All the relevant parts of local regulations.
- All relevant codes of practice.
- The relevant parts of the current editions of the following British Standards:-

INSTALLER GUIDE

BS 715	BS EN 1806	BS 5440 Part 2	BS 6891
BS 1251	BS 4543 Part 2	BS 5871 Part 1	
BS 1289 Part 1	BS 5440 Part 1	BS 6461 Part 1	

- In England and Wales, the current edition of the Building Regulations issued by the Department of the Environment and the Welsh Office.
- In Scotland, the current edition of the Building Standards (Scotland) Regulations issued by the Scottish Executive.
- In Northern Ireland, the current edition of the Building regulations (Northern Ireland) issued by the Department of the Environment for Northern Ireland.
- In the republic of Ireland the installation must be carried out by a competent person and installed in accordance with:
 - a) The current edition of IS 813 “Domestic gas installations”.
 - b) All relevant national and local rules in force.
 - c) The current building regulations

Where no specific instructions are given, reference should be made to the relevant British Standard Code of Practice.

4.2 If the appliance is intended to be installed to a chimney that was previously used for solid fuel, the flue must be swept clean prior to installation. All flues should be inspected for soundness and freedom from blockages.

4.3 Any chimney dampers or restrictors should be removed. If removal is not possible they must be fixed in the open position.

4.4 Normal adventitious ventilation is usually sufficient to satisfy the ventilation requirements of this appliance. In GB reference should be made to BS 5871 Part 2 and in IE reference should be made to the current edition of IS 813 “Domestic gas Installations” which makes clear the conditions that must be met to demonstrate that sufficient ventilation is available.

4.5 Note that soft wall coverings (e.g. embossed vinyl, etc.) are easily affected by heat. They may scorch or become discoloured when close to a heating appliance. Please bear this in mind when installing.

4.6 The minimum allowable distance from the outside of the appliance fascia to a corner wall having combustible material or any other combustible surface which projects beyond the front of the appliance is 50mm at either side (See figure 1). Although no side clearance is necessary to non-combustible surfaces we recommend a 100mm clearance for service access to fascia side fixing.

INSTALLER GUIDE

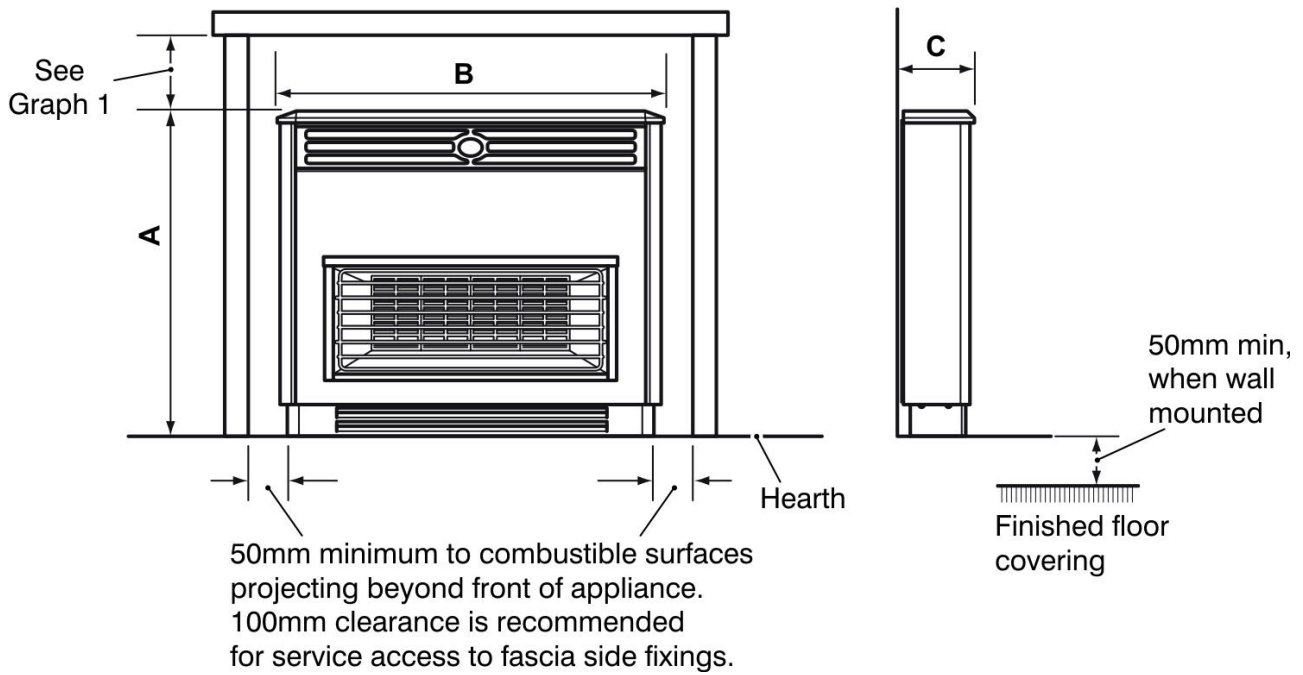

Model	Dimension 'A' (mm)	Dimension 'B' (mm)	Dimension 'C' (mm)
Brava	609	713	177
Charm	609	713	177
Esquire	609	708	177

Figure 1. Dimensions and clearances

4.7 The appliance must not be installed in any room, which contains a bath, or shower or where steam is regularly present.

4.8 An extractor fan may only be used in the same room as this appliance, or in any area from which ventilation for the appliance is taken, if it does not affect the safe performance of the appliance. Note the spillage test requirements detailed further on in this manual. If the fan is likely to affect the appliance, the appliance must not be installed unless the fan is permanently disconnected.

4.9 The appliance is fitted with an A.S.D (Atmosphere sensing device). If the appliance closes down after a period of operation for no apparent reason, the consumer should be informed to stop using the appliance until the installation and appliance have been thoroughly checked. The A.S.D will shut the appliance down if an unacceptable amount of harmful products of combustion accumulate. Under no circumstances should the A.S.D be altered or bypassed in any way. Only genuine manufacturers replacement parts should be fitted.

INSTALLER GUIDE

4.10 Allow a minimum clearance of **90mm** from the top surface of the appliance fascia to the underside of any shelf whether it is made from **combustible or non-combustible** materials. This clearance is necessary to allow the fascia to be lifted off for servicing and also allows the owner sufficient access to operate the control knob.

For a shelf made from **wood or other combustible materials deeper than 150mm**, add 12.5mm to the clearance for every 25mm of additional shelf depth (See graph 1).

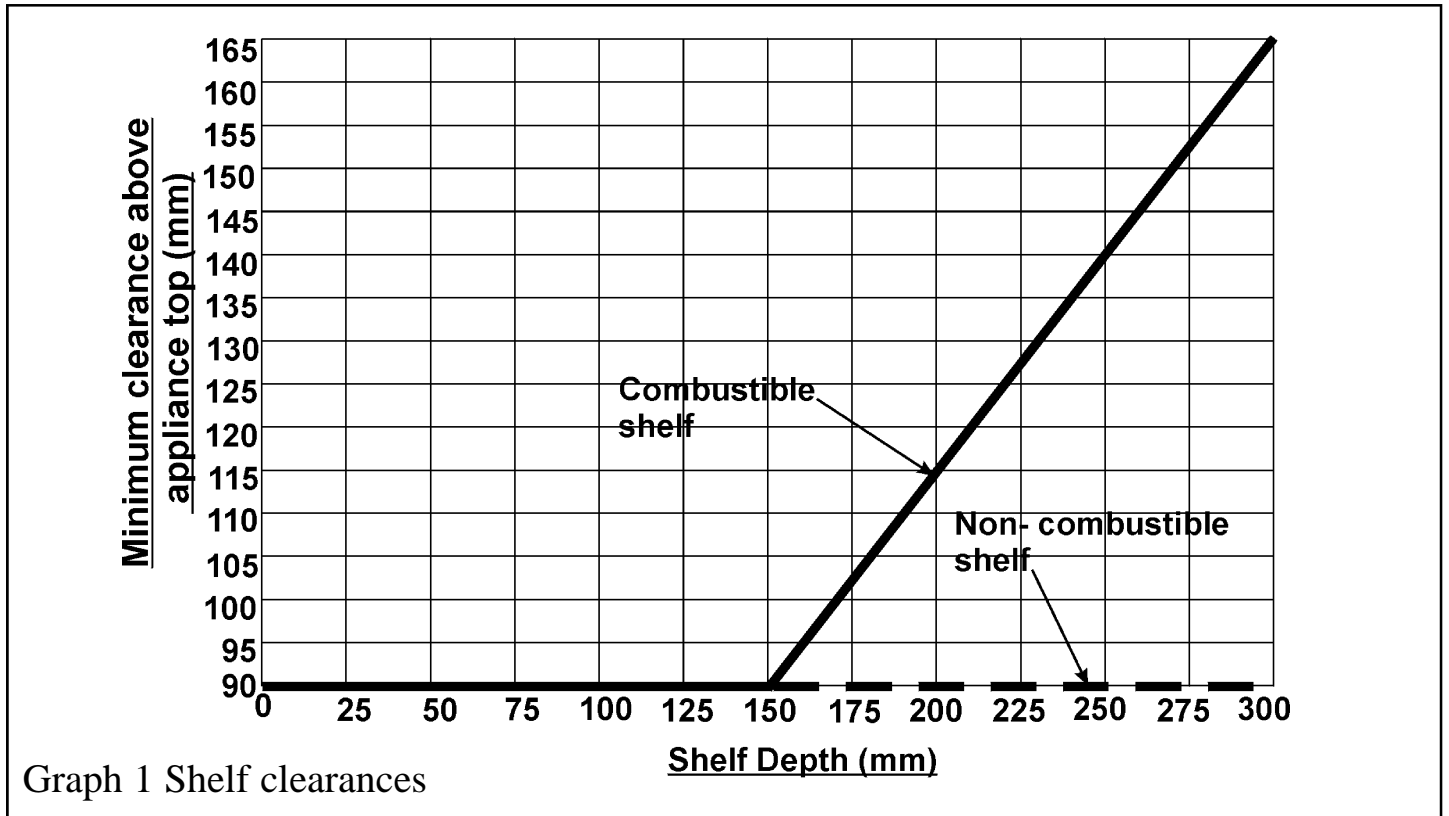

4.11 In the United Kingdom, as supplied, this appliance can be installed in the following situations: -

4.11.1 The appliance must be mounted on a non-combustible hearth **except when the conditions in section 4.11.4 are met** (N.B. conglomerate marble hearths are considered as non-combustible). The hearth must be at least 680mm wide x 300mm deep. The hearth material must be at least 12mm thick. The periphery of the hearth (or fender) should be at least 50mm above floor level to discourage the placing of carpets or rugs over it.

The appliance can be fitted to a purpose made proprietary class “O” 150°C surround.

Note: A spigot extension is available (Baxi part number 0595191). When fitted this shall extend through the closure plate for at least 15mm and have a minimum clearance of 50mm from the end to any surface.

INSTALLER GUIDE

4.11.2 Conventional fireplace

The fireplace opening must be within the following dimensions:

Width		Height	
Max.	440mm	Max.	610mm ^(*)
Min.	305mm	Min.	544mm

(*) The total height of the closure plate is 660mm and will accommodate a maximum opening height of 650mm (This allows a 10mm overhang). Heights above 580mm (Inclusive of sealing tape) will leave the sealing tape and closure plate visible above the appliance. A baffle is supplied with the fire which can be screwed to the appliance to cover the sealing tape and closure plate. When using the baffle, the height of the sealing tape and closure plate can be extended to a maximum 630mm before being visible (See section 8.2).

4.11.3 Precast flues

The appliance can be installed to a fireplace that has a properly constructed precast concrete or clay flue block system conforming to BS1289 or BS EN 1806. The appliance is suitable for installations conforming to older versions of BS1289 as well as the current standards. The flue blocks must have a minimum width not less than 63mm and a cross-sectional area not less than 13,000mm². Older editions of BS1289 required a cross-sectional area of 13,000mm². The current revision of the standard requires 16,500mm². This appliance is suitable in both cases.

The chimney should be one or two storeys high but not less than 3m vertical height and be correctly terminated. No mortar fangs between the blocks should be extruded into the flueway. If raking blocks are used, they must be fitted in accordance with the manufacturer's instructions. Mortar must not be allowed to drop down and accumulate in the raked positions.

The fireplace opening must be within the following dimensions:

Width		Height	
Max.	440mm	Max.	610mm ^(a)
Min.	305mm	Min.	544mm ^(b)

(a) The total height of the closure plate is 660mm and will accommodate a maximum opening height of 650mm (This allows a 10mm overhang). Heights above 580mm (Inclusive of sealing tape) will leave the sealing tape and closure plate visible above the appliance. A baffle is supplied with the fire which can be screwed to the appliance to cover the sealing tape and closure plate. When using the baffle the height of the sealing tape and closure plate can be extended to a maximum 630mm before

INSTALLER GUIDE

being visible (See section 8.2).

(b) Any opening visible below the appliance may be closed in.

4.11.4 Wall mounting to conventional and pre-cast flues.

The minimum height figures shown in the table below reflect that an extra 50mm (minimum) is required above the **finished floor level** when wall mounting (See figure 1). When the additional 50mm (minimum) is adhered to them the appliance can be fitted without a hearth.

The wall opening must be within the following dimensions:

Width		Height	
Max.	440mm	Max.	610mm ^(*)
Min.	305mm	Min.	594mm

(*) The total height of the closure plate is 660mm and will accommodate a maximum opening height of 650mm (This allows a 10mm overhang). Heights above 580mm (Inclusive of sealing tape) will leave the sealing tape and closure plate visible above the appliance. A baffle is supplied with the fire which can be screwed to the appliance to cover the sealing tape and closure plate. When using the baffle the height of the sealing tape and closure plate can be extended to a maximum 630mm before being visible (See section 8.2).

Wall mounting to a conventional fireplace.

Any opening visible below the appliance may be closed in but the depth of the catchment space within the wall opening must be as shown in figure 2.

Wall mounting to a pre cast flue.

Important: If the base of the opening is above the finished floor level it must be a maximum 350mm from the finished floor level. This will ensure that the air relief hole in the closure plate is not covered or reduced.

4.11.5 Metal flue box.

The appliance can be installed to a metal flue box conforming to BS715 Section 6 (For gas fires to BS5258: Part 5) having a minimum internal depth of 165mm. Incombustible mineral wool insulation of not less than 50mm

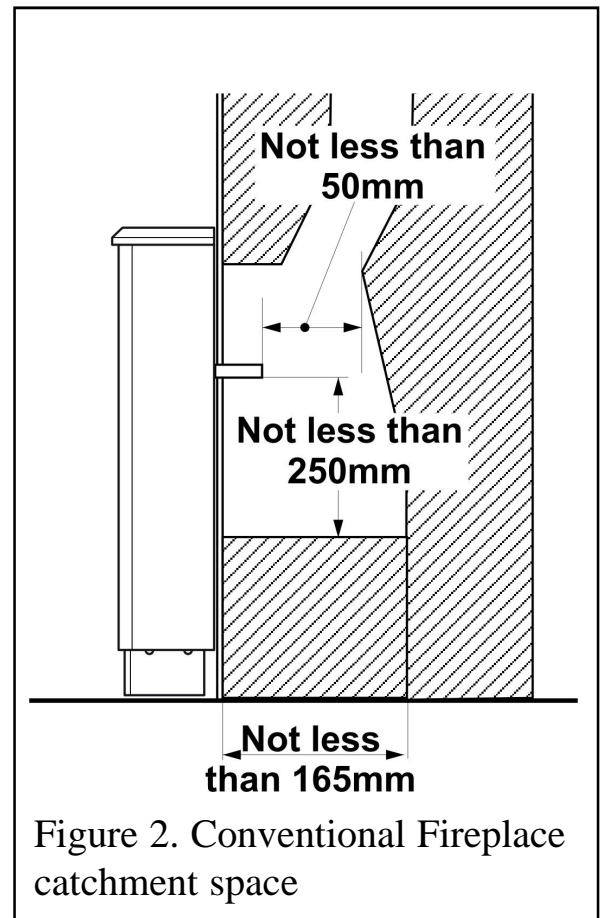

Figure 2. Conventional Fireplace catchment space

INSTALLER GUIDE

thickness must be applied to the top surface of the metal flue box.

The opening must be within the following dimensions:

Width		Height	
Max.	440mm	Max.	610mm ^(*)
Min.	380mm	Min.	544mm

(*) The total height of the closure plate is 660mm and will accommodate a maximum opening height of 650mm (This allows a 10mm overhang). Heights above 580mm (Inclusive of sealing tape) will leave the sealing tape and closure plate visible above the appliance. A baffle is supplied with the fire which can be screwed to the appliance to cover the sealing tape and closure plate. When using the baffle the height of the sealing tape and closure plate can be extended to a maximum 630mm before being visible (See section 8.2).

4.12 The following flues are suitable:

- 225mm x 225mm conventional brick flue.

If a flue liner is used, it must be a minimum of 125mm diameter. The liner must be sealed to the surrounding area above the fireplace opening and to the top of the chimney. An approved terminal must be fitted.

- A properly constructed precast flue conforming to B.S 1289 or BS EN 1806.
- A flue pipe with a minimum diameter of 127mm. See B.S 6461 Part 1 for suitable materials. Metal flue pipes must comply with B.S 715. See section 4.11.5 of this guide for flue box opening sizes.

4.12.1 The flue must conform to BS 5440: Part 1 in design and installation.

The flue, measured from the bottom of the fireplace opening to the bottom of the terminal, shall be not less than 3m in actual vertical height. When calculated in accordance with BS 5440: Part 1 Annex A, the minimum **equivalent** height of the flue shall be 2.0m of 125mm dia. flue pipe.

4.12.2 The flue must be clear of any obstruction and its base must be clear of debris.

4.12.3 The flue must be completely sealed so that combustion products do not come into contact with combustible materials outside the chimney.

4.12.4 The flue must serve only one fireplace.

4.12.5 Proprietary terminals must comply with BS 715 or BS 1289. Any terminal or termination must be positioned in accordance with BS 5440 Part 1 to ensure that the products of combustion can be safely dispersed into the outside atmosphere. Where the appliance is connected to an unlined brick chimney it is generally unnecessary for the chimney pot to be replaced or for a terminal to be fitted unless the flue has a diameter smaller than 170mm.

INSTALLER GUIDE

4.13 If the fireplace opening is an underfloor draught type, it must be sealed to stop any draughts.

4.14 The flue spigot and any spigot extension must be capable of passing through the closure plate by at least 15mm with a minimum clearance of 50mm between its open end and the nearest obstruction.

There must also be a minimum clearance of 165mm between the back of the closure plate and the back of the catchment space.

On conventional flues the catchment space below the flue spigot must extend at least 250mm downwards measured from the bottom of the flue spigot (See figure 2).

4.15 The front of the fireplace should be flat over an area sufficient to ensure a good seal with the closure plate. The flat surface should extend for a height equal to that of the closure plate plus 20mm and for a width equal to that of the closure plate plus 40mm.

4.16 If the fire is to be fitted against a wall with combustible cladding, the cladding must be removed from the area shown in figure 3.

4.17 The space between the fireplace front face and the back of the fascia must not be filled in.

4.18 If the fireplace opening is greater than the acceptable dimensions given in this guide, do not use the back of a fire surround or marble to reduce the opening. This may cause cracking of the surround back or marble.

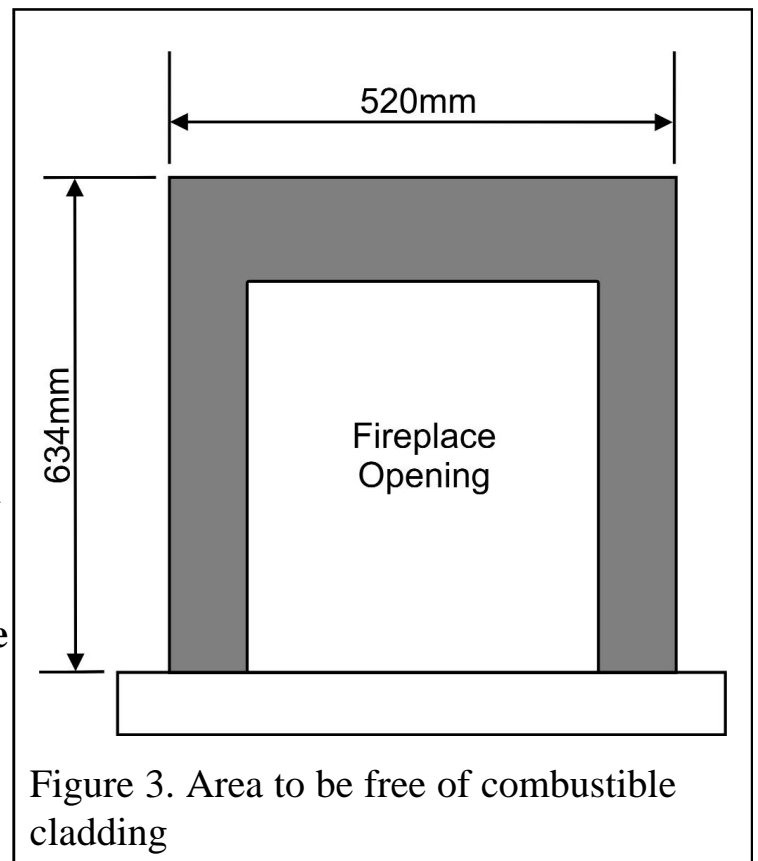

Figure 3. Area to be free of combustible cladding

INSTALLER GUIDE

5 PRE-INSTALLATION PREPARATION

5.1 Unpacking.

This appliance is supplied completely assembled except for:-

- 4 radiants which are in a cardboard pack inside the firebox.
- The closure plate
- Literature pack
- An olive & olive nut for gas line connection
- Rear baffle for closure plate coverage (where required)
- Battery (Only supplied with electronic ignition models)
- Control knob.
- 4 Fixing extension brackets.
- 4 flat head self tapping screws (For securing the upper extension brackets).

Remove all the items carefully to prevent damage. Some items may be contained in the packaging fitments - Examine the packaging carefully before discarding. Check that all the items are present and undamaged.

5.2 Fireplace flue pull.

Close all doors and windows in the room in which the appliance is to be installed. After confirming with a match that smoke is drawn into the flue, light a 13 gram smoke pellet and check that there is a definite flow through the flue. Verify outside that the smoke exits from one terminal only and that the termination is suitable. Observe, where possible, upstairs rooms and loft spaces for signs of escaping smoke indicating a defective flue. If there is not a definite flow warm the flue for a few minutes and repeat the smoke pellet test. If there is still no definite flow the flue may need remedial work – **Do not fit the appliance until there is a definite flow through the flue.**

5.3 Appliance preparation.

5.3.1. Stand the fire upright.

5.3.2. Remove the two transit screws from near the top of the back panel wings (See figure 4).

5.3.3. Remove the two fascia retaining screws located at the rear of the fascia near the bottom corners.

5.3.4. Lift the fascia up and forward to clear the rear top location. Store in a safe place.

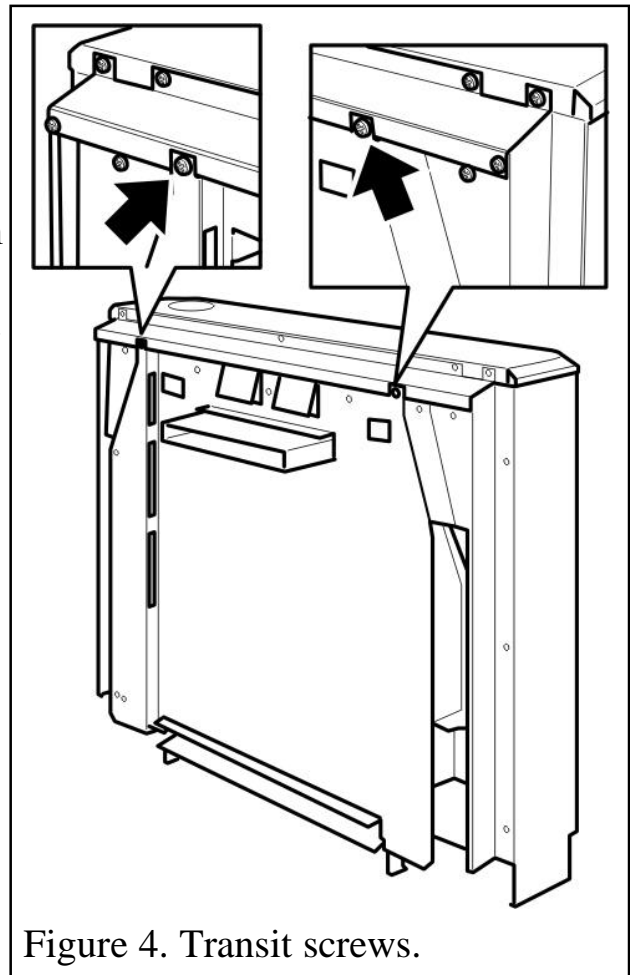

Figure 4. Transit screws.

INSTALLER GUIDE

5.3.5. Remove the radiant pack.

5.3.6. Remove any protective film from all the bright trims.

5.3.7. If the fire is fitted to a recessed fireplace, an extension flue spigot up to a maximum total length of 125mm may be used. The extension must be a tight fit over the flue spigot and be secured by two self tapping screws. Note the minimum clearance required as shown in figure 2.

5.4 Fitting the battery to electronic ignition models.

1. At the front of the electronic spark generator there is a removable circular battery cover. Unscrew the cover in an anticlockwise direction.

2. Remove any protective film from the battery and place into the generator. The negative (-) terminal should go in first. The battery cover is marked with (+).

3. Screw on the cap.

5.5 Checking the ignition.

5.5.1 Manual ignition.

Before attempting to install, it is worth checking that the piezo electric spark ignition system operates satisfactorily.

To initiate the spark, temporarily fit the control knob to the spindle. Depress the knob and while keeping it depressed, turn to the 1/IGN position. Two separate sparks should track from the electrode pin to the thermocouple tip. If there are no sparks or incorrect tracking, check the spark gap between the electrode wire and thermocouple tip (See figure 5).

If the spark gap is correct, check the ignition wiring.

5.5.2 Electronic ignition.

Before attempting to install, it is worth checking that the electronic spark ignition system operates satisfactorily.

To initiate the spark, temporarily fit the control knob to the spindle. Apply pressure to the top of the control knob spindle. Sparks should be generated between the electrode and thermocouple tip on the pilot unit. If there are no sparks or incorrect tracking, check the spark gap between the electrode wire and thermocouple tip (See figure 5).

If the spark gap is correct, check the ignition wiring.

5.6 Fitting the closure plate.

The spigot opening in the closure plate has two 'flange' sections. Fold along the perforated line of **Flange 1**. The dimensions of the closure plate will be as in figure 6.

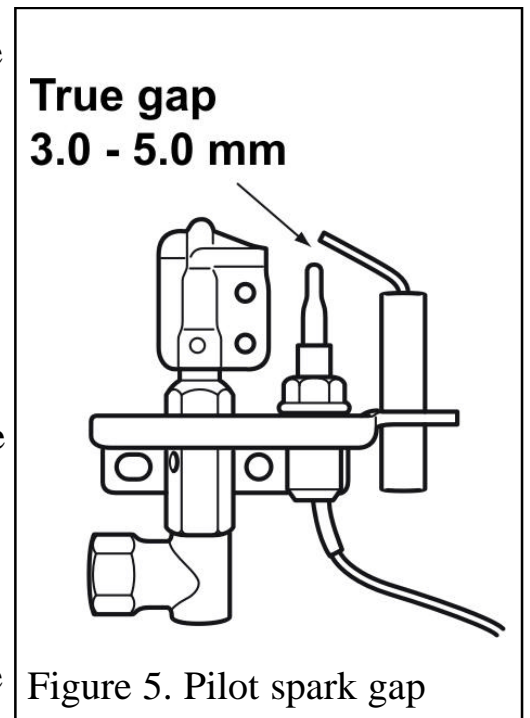

INSTALLER GUIDE

The closure plate has an opening at the bottom for a central gas feed pipe. The gap between the pipe and this opening should be sealed with tape after connection. If a central feed pipe is not required the opening should be completely sealed with tape.

5.6.1 Hearth mounting

(See figure 7).

The closure plate must be fitted and sealed to the hearth and fireplace opening using a suitable heat resistant material. If necessary cut the closure plate but make sure that it overlaps the fireplace opening sufficiently to allow satisfactory sealing. Make sure that the square air relief opening is fully within the fireplace opening.

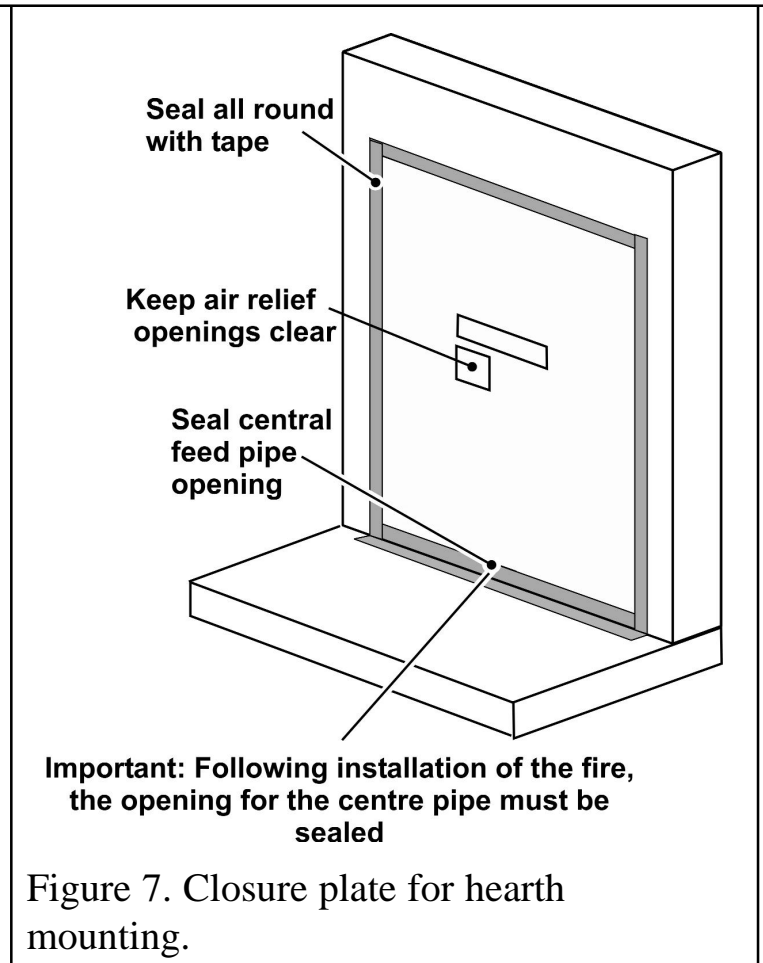
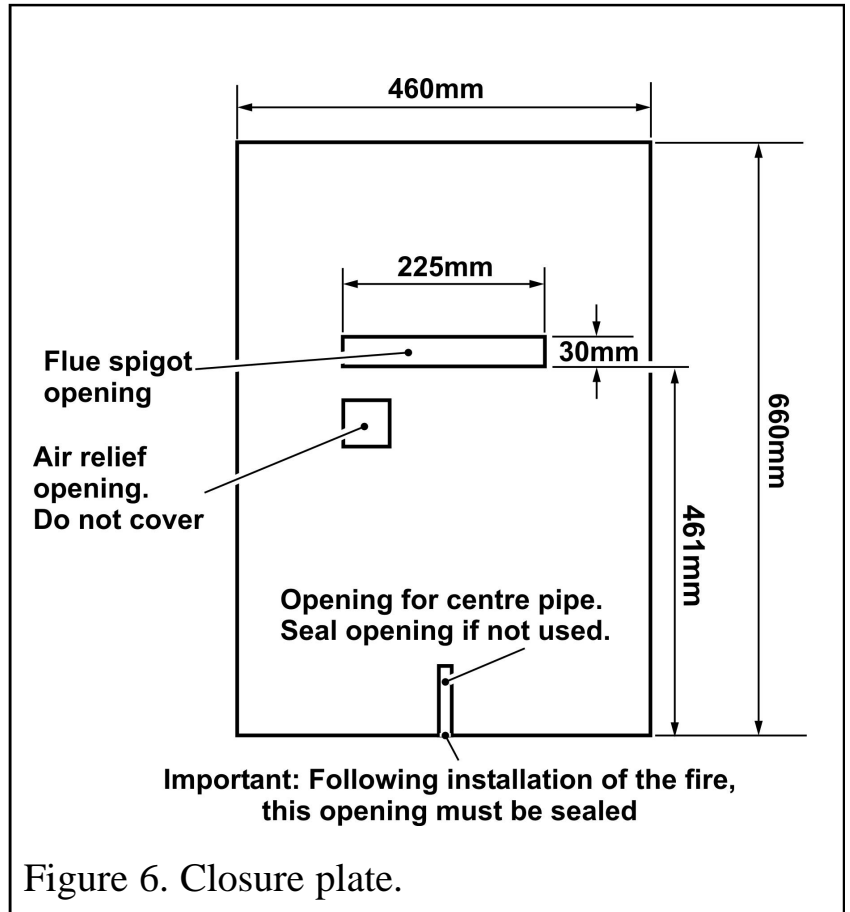

INSTALLER GUIDE

5.6.2 Wall mounting

(See figure 8).

The closure plate must be fitted and sealed to the hearth and fireplace opening using a suitable heat resistant material. If necessary cut the closure plate but make sure that it overlaps the fireplace opening sufficiently to allow satisfactory sealing. Make sure that the square air relief opening is fully within the fireplace opening.

The bottom of the appliance must be at least 50mm above any carpet or other floor covering. To achieve this, the bottom of

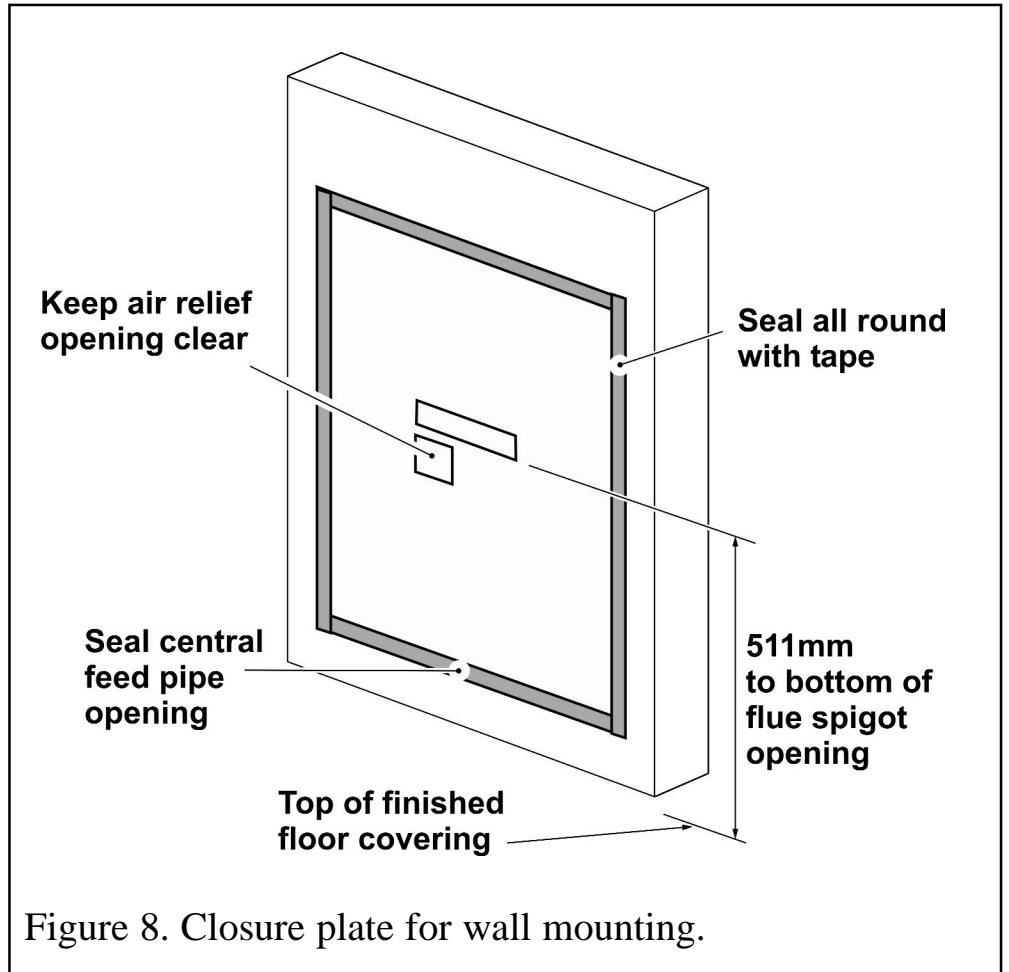

Figure 8. Closure plate for wall mounting.

the flue spigot opening must be at least the minimum dimension shown in figure 8.

5.6.3 Check the flue pull with closure plate fitted by applying a lighted match or smoke match to the flue spigot opening in the closure plate and observe the smoke. If there is a definite flow continue with the installation. If not check the fitting of the closure plate. The fireplace flue pull check described in section 5.2 should have confirmed that the fireplace itself is satisfactory.

INSTALLER GUIDE

6 APPLIANCE INSTALLATION

6.1 Using the extension brackets.

Supplied with the fire are four extension brackets and four fixing screws. The extension brackets are for use where the wall fixing holes in the gas fire are located adjacent to areas that are not substantial enough to enable an adequate fixing point (i.e. where the fixing holes in the gas fire are located adjacent to areas that are made of plaster that has no brick underneath or where the fixing holes fall adjacent to the side of a metal flue).

6.1.1 Fitting the lower extension brackets.

(See figure 9).

1. Remove the two securing screws from the rear of the brace brackets, locate the extension bracket as in figure 1 and refit the screws removed previously.

6.1.2 Fitting the upper extension brackets.

(See figure 10).

1. Fit the upper extension brackets to the left and right hand sides of the flanges at the rear of the gas fire as in figure 10.

6.2 Installing to a hearth.

6.2.1 Place the fire centrally on the hearth making sure that the spigot lines up with the spigot hole in the closure plate. Gently slide the appliance into place **being careful not to scratch the hearth**. The spigot must enter the closure plate to a depth of at least 15mm.

6.2.2 Level the fire by loosening the lock nuts and turning the levelling screws in the feet up or down as required while they bear on the hearth. When the fire is level and square to the wall, retighten the lock nuts.

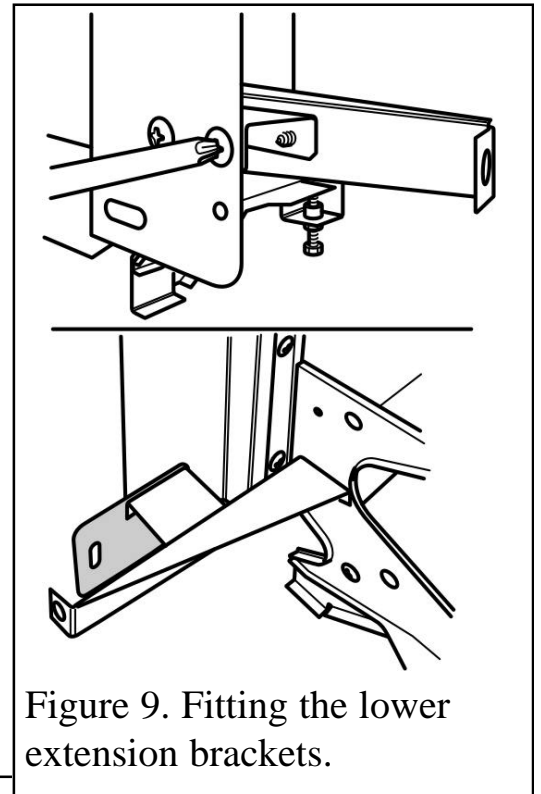

Figure 9. Fitting the lower extension brackets.

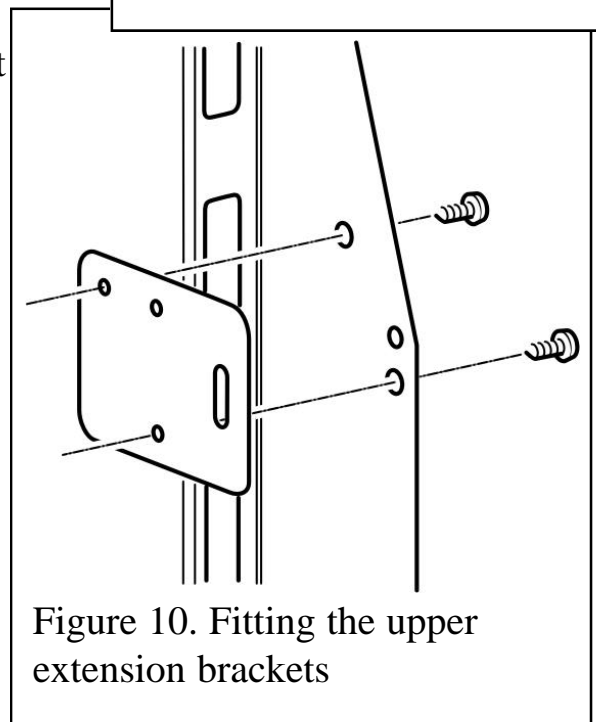

Figure 10. Fitting the upper extension brackets

INSTALLER GUIDE

6.3 Wall mounting.

The fixing hole positions in relation to the flue spigot opening are shown in figure 11. Mark these positions on the wall. The positions can alternatively be marked by placing the fire in position and marking the wall through the holes in the back panel. Drill and plug the holes using no. 10 wall plugs. Place the fire in position and secure with four no. 10 x 2in. woodscrews.

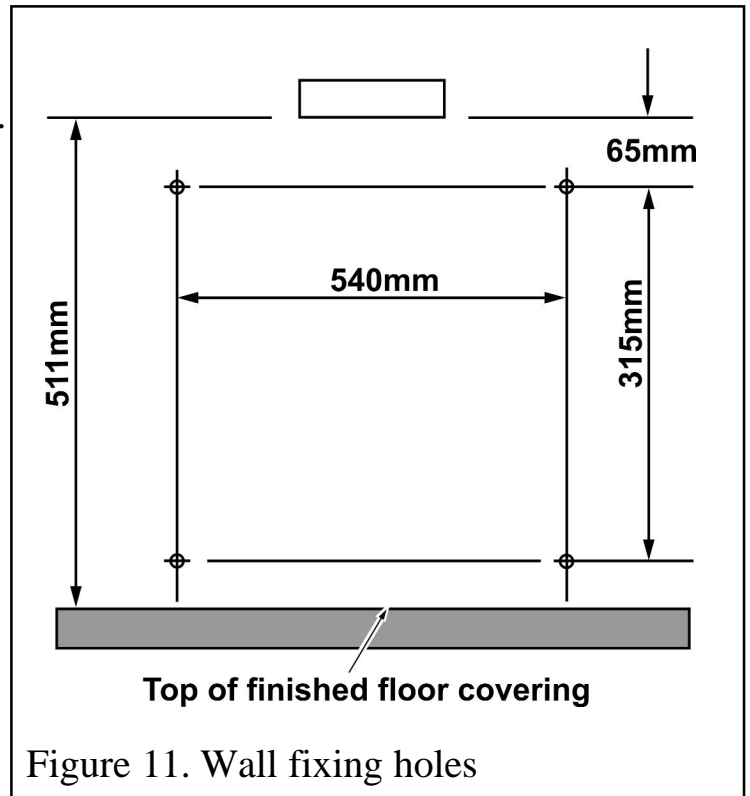

Figure 11. Wall fixing holes

6.4 Gas supply connection.

8mm rigid tubing must be used to connect the gas supply to the appliance. An olive and nut are provided for connection to the “T” connector on the appliance. The

connector can be rotated to allow connection from either side or the rear. The connector includes a valve for isolating the gas supply.

The closure plate has a cut-out in the base for rear connection. Seal the gap between the cut-out and the supply pipe.

Pressure check the installation pipework for gas soundness. In the United Kingdom check in accordance with the current edition of BS6891. In the Republic of Ireland refer to the current edition of IS 813 “Domestic gas installations”.

6.5 Radiants installation.

Important: Fit the radiants ensuring that their rear face rests against the horizontal ribs in the rear panel. There will be a small gap between their bottom front edges and the retaining channel at the front of the radiant box.

6.6 Flue restrictor adjustment.

(See figure 12).

The appliance has an integral adjustable flue draught restrictor. This is supplied set in the fully open (unrestricted) position and in most cases no adjustment should be necessary. It can be reset to a fully restricted position if the flue draught is excessive. **The restrictor must remain in its**

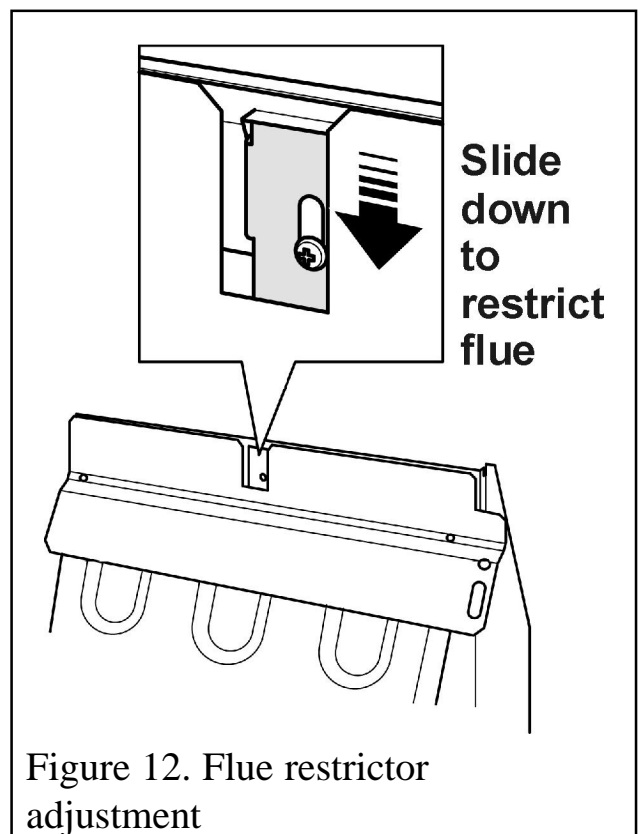

Figure 12. Flue restrictor adjustment

INSTALLER GUIDE

fully open position if the flue has an equivalent height of 4m or less (as calculated in accordance with BS5440: Part 1 Appendix A) or where a pre-cast flue is used.

To close the restrictor:

1. Loosen the screw situated behind the cut-out in the black upper heat shield. Do not fully remove the screw.
2. Push the restrictor firmly down as far as it will go. The top of the slot in the restrictor bracket should touch the screw.
3. Fully tighten the screw.

There may be certain exceptional circumstances where closing the restrictor causes the fire to fail the spillage test (See section 9). In such cases the restrictor will have to be reopened.

7 CONTROL & PRESSURE CHECKS

7.1 Check control settings.

7.1.1 If closed, open the isolating valve at the inlet 'T' connector.

7.1.2 To check the control positions temporarily place the fascia loosely over the engine. Fit the control knob over the gas tap spindle.

7.1.3 Manual ignition: Depress the control knob and turn anticlockwise partially towards the 1/IGN position until some resistance is felt. Keep depressed at this position for a few seconds to purge air from the system then, while keeping it depressed, turn fully to the 1/IGN position. A spark should be generated at the pilot while turning. The spark should ignite the pilot. If it does not, keeping the knob depressed, continue to turn the knob anticlockwise. A **second spark** should be generated at the pilot while turning. This spark should ignite the pilot.

7.1.3 Electronic ignition: Depress the control knob slightly and turn anticlockwise towards the 1/IGN position. Do not apply too much pressure as this will cause resistance to be felt. Depress the control knob. Sparks should be generated at the pilot. The sparks should ignite the pilot. If the pilot does not light, turn the control knob back to the 'OFF' position and try again.

7.1.4 When pilot ignition has been achieved, keep the control knob depressed for approximately ten seconds to allow the thermocouple probe to warm up and then release it. If the pilot does not remain alight, ensure that the air has been purged, that the pilot orifice is clear and that the thermocouple connections are sound. Replace the pilot unit if necessary (See servicing section of this manual).

INSTALLER GUIDE

7.1.5 Check all the control settings. These are: -

Control Knob Position	Radiants Condition
2	Centre radiants on low. Outer radiants off.
3	Centre radiants fully on. Outer radiants off.
4	Centre radiants fully on. Outer radiants on low.
5	All radiants fully on.

7.2 Flame supervision and spillage monitoring system.

The pilot unit incorporates a system that will automatically shut off the gas supply if the pilot flame goes out or if there is insufficient oxygen due to spillage or lack of ventilation.

Check that the system operates properly as follows;

7.2.1 Light the appliance. Set at position 5 and leave for one minute.

7.2.2 Turn back to “OFF” to extinguish the pilot. **Note the time when the pilot goes out.** Listen for a snap sound at the gas tap. **Note the time when the sound is heard.** An electromagnetic valve shutting off the gas supply through the tap causes this sound. The valve is located in the body of the tap. The valve should operate **within 60 seconds of the pilot going out.** If the valve does not operate within this time limit do not allow the appliance to be used until the fault has been corrected.

This monitoring system must not be adjusted, bypassed or put out of operation. This monitoring system, or any of its parts, must only be exchanged using Baxi authorised parts.

7.3 Check reference pressure.

The appliance is pre-set to give the correct heat input at the inlet pressure shown in section 3 of this manual. No adjustment is necessary.

7.3.1 Detach the control knob from the spindle. Remove the fascia.

7.3.2 Check the burner pressure by fitting a pressure gauge at the test point. The test point is on the gas tap. Check the pressure with the appliance alight and set at maximum output (Control position 5).

7.3.3 After checking, turn off the appliance. Remove the pressure gauge and replace the test point sealing screw. Relight the appliance. Turn to the maximum output position and test around the sealing screw for gas soundness with a suitable leak detection fluid.

7.3.4 If all the above checks are satisfactory, continue with the installation. If not, check the control and ignition circuitry and components as described in the servicing section of this manual.

INSTALLER GUIDE

8 FASCIA FITTING

8.1 To fit the fascia.

8.1.1 Place the fascia over the engine.

Make sure that the top rear of the fascia locates fully into the 'U' shaped notch of the engine back panel (See figure 13).

8.1.2 Fit the control knob firmly on to the control spindle.

8.1.3 Secure the fascia using the two screws previously removed. There are two holes in the fascia. Use the bottom hole.

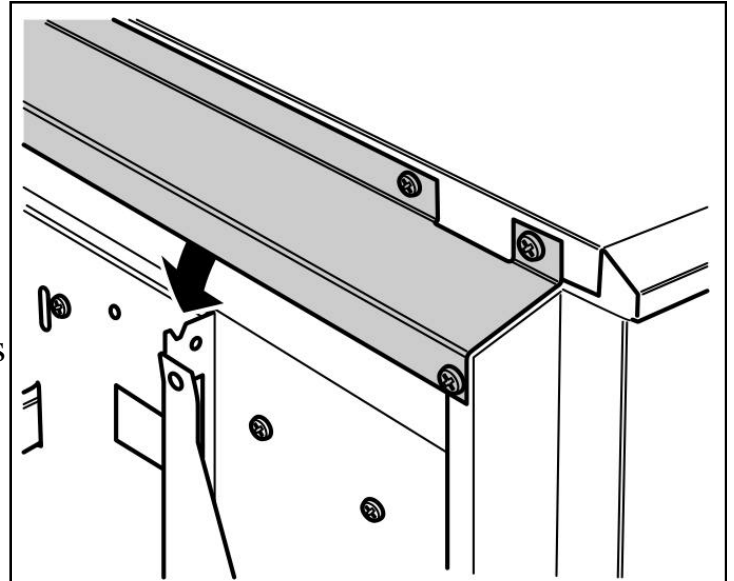

Figure 13. Fascia top location

8.2 To fit the closure plate baffle.

The closure plate baffle is supplied with the fire and is intended for use where the height of the closure plate and sealing tape is greater than 580mm. When using the baffle the height of the sealing tape and closure plate can be extended to a maximum 630mm.

8.2.1 At the rear top corners of the fascia there are two screws, one at each side.

8.2.2 Loosen the screws but do NOT remove them.

8.2.3 Locate the baffle onto the screws as in figure 14. The baffle is angled and should lean towards the rear of the fire.

8.2.4 Tighten the screws to secure.

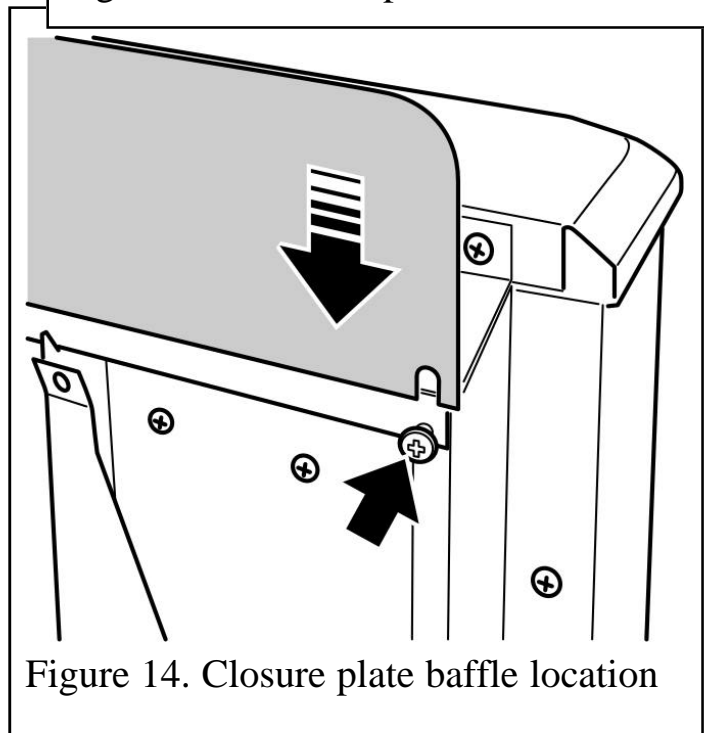

Figure 14. Closure plate baffle location

INSTALLER GUIDE

9 SPILLAGE CHECK

A spillage test must be made before the installed appliance is left with the customer.

1. Close all doors and windows in the room containing the fire.
2. Light the appliance and set the control knob to the maximum position (Position 5).
3. Leave the appliance on for five minutes.
4. Place a smoke match tube (with lighted match) horizontally underneath the radiant box but touching the top lip of the box. The tube should be between the two centre radiants. The tip of the match should project between 2mm and 5mm beyond the lowest edge of the radiant box lip (See figure 15).
5. The installation is satisfactory if the smoke is drawn into the appliance. If the smoke is not drawn into the appliance, leave the appliance alight at the maximum setting for a

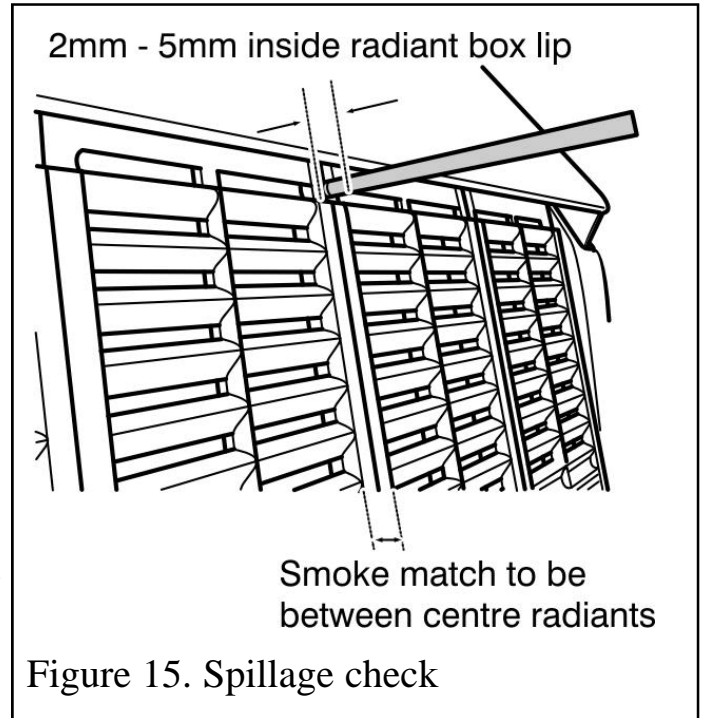

further ten minutes and then repeat the test. If the smoke is still not drawn into the appliance, inspect the sealing of the closure plate. If the sealing is satisfactory but the appliance is installed with the flue restrictor in the closed position (see section 6.6), reopen the restrictor, reseal the appliance and retest. **If smoke is still not drawn into the appliance disconnect the appliance and seek expert advice**

6. If the above test is satisfactory, open all internal connecting doors, hatches, etc. in the room. Keep all doors and windows that open to the outside of the building closed. Recheck for spillage as above. If an extractor fan is installed in the same room as the appliance or a connecting room, check that spillage does not occur with the fan operating and all doors and other openings between the fan and the appliance open. If the test is satisfactory continue with the installation. **If the test is not satisfactory disconnect the appliance and advise the customer of the cause of failure.**

INSTALLER GUIDE

10 FINAL REVIEW

- Make sure that the dress guard is securely in position.
- Recheck the operation of the fire at all control positions. **Explain to the customer the operation of the ignition system and that manual ignition models are fitted with a two-spark ignition system. (See section 7.1.3).**
- Visually inspect the appliance. Clean off any marks incurred during installation.
- Advise the customer how to operate the fire.
- Explain to the customer that the appliance has a flame failure and spillage monitoring system. Point out the explanation of this system shown in the owner guide. Advise that if the fire goes out for any reason, wait at least three minutes before relighting. Stress that if the monitoring system repeatedly shuts off the fire, the appliance should be switched off and a specialist should be consulted.
- Advise that the dressguard can be removed to replace the radiants.
- Advise that the fire may give off a slight odour while new. This is quite normal and it will disappear after a short period of use.
- Advise that any cleaning must only be carried out when the fire is off and cold.
- Advise the customer that they should read the owner guide before operating the fire and always follow the advice in the section headed “Cleaning your fire”.
- Advise the customer that the appliance can be lit with a match if necessary by inserting it through the central opening at the bottom of the radiant box.
- Recommend that the appliance should be serviced and the chimney inspected by a competent person (In the UK a CORGI registered person) at least annually. If the appliance is in premises in the United Kingdom occupied by a tenant, point out that by law a landlord must have any gas appliance, flue and pipework which is situated in a tenant’s premises checked for safety at least every 12 months.
- Mention that the radiants may become brown with use, that this is quite normal and has no adverse effect.
- Hand this guide to the customer.

11 SERVICING & PARTS REPLACEMENT

- Always turn off the gas supply and allow to cool completely before commencing any servicing (The appliance inlet “T” connector incorporates an isolating valve).
- It is recommended that, at least once a year, the appliance is disconnected and the catchment space behind the closure plate checked and cleared of any debris. The closure plate must be resealed to the wall after checking.
- Check that soot or debris is not impairing the electrode spark or pilot burner.
- Check that soot or debris is not blocking any of the holes in the main burner.
- Always test for gas soundness and spillage after servicing the appliance.

Note: For models fitted with electronic ignition it is advisable to remove the battery from the electronic spark generator before continuing to service the appliance. This will prevent accidental operation of the ignition system.

11.1 To remove the fascia.

- 11.1.1* Remove the control knob by pulling clear of the gas tap spindle.
- 11.1.2* Remove the two fascia retaining screws located at the rear of the fascia near the bottom corners. Note from which holes the screws are removed.
- 11.1.3* Lift the fascia up and forward to clear the rear top location.
- 11.1.4* Replace in the reverse order. Make sure that the top rear of the of the fascia locates fully into the ‘U’ shaped notch of the engine back panel (See figure13). Make sure that the radiants are not dislodged when refitting the fascia.

11.2 To replace radiant(s).

- 11.2.1* Remove the dress guard by gently pulling it in the centre with one hand, and carefully springing out one end from the fascia with the other. Slide the opposite side of the dress guard clear of the fixing holes. **Take care not to scratch the trim.**
- 11.2.2* Remove the old radiant(s). Fit the new radiant(s) **ensuring that their front face rests against the front of the retaining channel.**
- 11.2.3* Replace the dress guard.

11.3 To replace the pilot unit.

- 11.3.1* Remove the fascia as section 11.1 above.
- 11.3.2* Disconnect the thermocouple connection at the bottom of the gas tap.
- 11.3.3* Disconnect the pilot pipe from the gas tap. It is the upper connection at the right side of the tap.
- 11.3.4* Remove the first screw securing the dust cage to the pilot unit & burner bracket. Carefully remove the dust cage and place aside. Remove the second screw securing the pilot unit to the burner bracket.

INSTALLER GUIDE

11.3.5. Disconnect the electrode lead from below the pilot electrode.

11.3.6. Carefully remove the pilot unit together with the pilot pipe then disconnect the pipe from the pilot unit.

11.3.7. Replace in the reverse order.

Note: 1 The pilot unit must be replaced as a whole assembly. Its individual components are not separately replaceable.

2. Once removed, ensure that the dust cage is cleaned before refitting. Make sure that it locates squarely onto the pilot unit without any gaps between the cage edges and the pilot unit.

11.4 To remove the piezo generator (manual ignition models).

11.4.1. Remove the fascia as section 11.1.

11.4.2. Disconnect the electrode lead from below the pilot electrode.

11.4.3. Disconnect the control spindle & adapter from the gas tap by removing the split pin. Lift the adapter clear of the gas tap spindle.

11.4.4. Remove the circlip holding the piezo generator to the tap.

11.4.5. Replace in the reverse order. Make sure that the control knob with spindle is correctly turned to agree with the gas tap position before refitting the split pin.

11.5 Note for electronic ignition.

Servicing the gas valve area of the gas fire will require the electronic spark generator and mounting bracket to be removed. This will allow access to the pipe nuts etc. To do this remove the two screws that secure it to the lower right support foot then move it to one side. Refit after servicing is complete.

There will be a fascia support bracket located using the same screws as for the electronic generator and support bracket. ***It is important that the 'fascia support bracket' is fitted to the support foot before the 'electronic generator and support bracket assembly'.***

11.6 To remove the complete burner module, pipes and pilot.

11.6.1. Remove the fascia as section 11.1.

11.6.2. Support the inlet 'T' connector to avoid straining the pipework and disconnect the appliance from the inlet 'T' connector.

11.6.3. Manual ignition: Disconnect the control spindle & adapter from the gas tap by removing the split pin. Lift the adapter clear of the gas tap spindle.

It is important to note the orientation of the 'D' flat at the top of the spindle as it will need to be replaced in the same way.

11.6.3. Electronic ignition: Remove the lower 'R' clip from the base of the spindle assembly. Unscrew the brass nut that secures the microswitch bracket to the top of the gas valve. Lift the microswitch bracket and spindle clear of the gas valve top.

It is important to note the orientation of the 'D' flat at the top of the spindle as it

INSTALLER GUIDE

will need to be replaced in the same way.

11.6.4. Detach the left end of the burner module from the radiant box by removing one screw and a wingnut (See figure 16).

11.6.5. Carefully slide the burner module to the right to free it from the right side of the radiant box (See figure 16).

11.6.6. Remove the pipes, gas tap or injectors as required.

11.6.7. Replace in the reverse order.

Take care when replacing the injectors. The injectors have ceramic tips at each end. It is important not to allow jointing compound to get on either end of the injectors.

Make sure that the control knob with spindle is correctly turned to agree with the gas tap position before refitting the split pin.

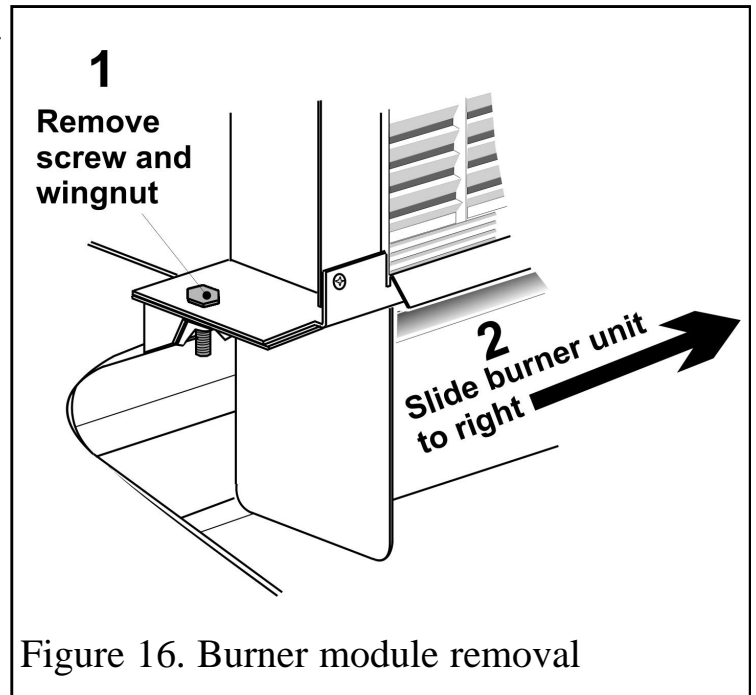

11.7 To grease the gas tap

11.7.1. Remove the burner module as section 11.6.

11.7.2. Remove the circlip holding the piezo generator to the tap and remove the piezo generator.

11.7.3. Remove the two screws from the head of the gas tap and remove the gas tap head.

11.7.4. Remove the spindle and spring from the tap.

11.7.5. Note the position of the slot in the plug. Mark this position on the tap body.

11.7.6. Rotate the plug and pull it out of the tap.

11.7.7. Clean and grease the plug lightly with suitable grease. Do not apply excessive grease. Particularly, make sure that the gas ports are not restricted by grease.

11.7.8. Push the plug back into the tap body. Line up the slot in the plug with the mark previously made on the tap body.

11.7.9. Reassemble in the reverse order making sure that the components are correctly engaged. Check the operation of the tap and ignition. Make sure that the control knob with spindle is correctly turned to agree with the gas tap position before refitting the split pin / 'R' clip.