

BAXI FIRES DIVISION

INSTALLER GUIDE

Model 541

fitted with

Decadent or
Chic fascia

ROOM SEALED RADIANT / CONVECTOR
GAS FIRE



(GC No. 32-032-65)

**THIS APPLIANCE IS FOR USE WITH NATURAL GAS (G20).
THIS APPLIANCE IS SUITABLE ONLY FOR INSTALLATION IN THE UNITED
KINGDOM (GB) AND THE REPUBLIC OF IRELAND (IE).**

We trust that this guide gives sufficient details to enable this appliance to be installed and maintained satisfactorily. However, if further information is required, our

Baxi Fires Division Technical Helpline will be pleased to help.

Telephone **08706 061 065** (National call rates apply in the United Kingdom). In the Republic of Ireland telephone **0044 8706 061 065**.

INSTALLER: Please leave this guide with the owner

BAXI ● VALOR ● WONDERFIRE

INSTALLER GUIDE

Safety First.

Baxi Fires Division fires are CE Approved and designed to meet the appropriate British Standards and Safety Marks.



Quality and Excellence.

All Baxi Fires Division fires are manufactured to the highest standards of quality and excellence and are manufactured under a BS EN ISO 9001 quality system accepted by the British Standards Institute.



The Highest Standards

Baxi Fires Division is a member of the Society of British Gas Industries which works to ensure high standards of safety, quality and performance.



Careful Installation

Baxi Fires Division is a CORGI registered company. All our gas fires must be installed by a competent CORGI Registered Installer in accordance with our Installer Guide and should not be fitted directly on to a carpet or floor of combustible material.

B A X I F I R E S D I V I S I O N

Baxi Fires Division, Erdington, Birmingham B24 9QP

www.firesandstoves.co.uk

Because our policy is one of constant development and improvement, details may vary slightly from those given in this publication

INSTALLER GUIDE

CONTENTS

<u>Section</u>	<u>Heading</u>	<u>Page</u>
1.	SAFETY	4
2.	APPLIANCE DATA	4
3.	LIST OF AVAILABLE KITS	7
4.	GENERAL INSTALLATION REQUIREMENTS	7
5.	UNPACKING AND PRELIMINARY CHECKS	12
6.	GAS SUPPLY CONNECTION	14
7.	WALL PREPARATION	15
	7.1 Select appliance position.	15
	7.2 Constructing a recessed opening.	15
	7.3 Combustible wall materials.	16
	7.4 Cutting the flue hole for brick, stone etc. building.	17
	7.5 Cutting the flue hole in timber frame buildings.	17
	7.6 Prepare appliance fixing holes.	18
8.	FLUE TERMINAL INSTALLATION	19
	8.1 Cutting flue to size.	19
	8.2 Fitting to wall.	21
	8.3 Fitting the terminal guard.	22
9.	GAS CONNECTION	22
10.	CERAMIC COALS INSTALLATION	23
11.	CERAMIC PEBBLES INSTALLATION	25
12.	WINDOW FITTING	27
13.	FULL OPERATING CHECKS	27
14.	FASCIA FITTING	29
	14.1 Fitting the Decadent fascia	29
	14.2 Fitting the Chic fascia	30
15.	FINAL REVIEW	31
16.	SERVICING & PARTS REPLACEMENT	32
	16.1 To remove the fascia.	32
	16.2 To remove window unit.	34
	16.3 To remove the ceramic fuel effect and rear wall.	34
	16.4 To remove the complete burner module.	34
	16.5 To remove the burner from the burner module.	35
	16.6 To remove the injector.	35
	16.7 To remove the pilot unit.	35
	16.8 To remove the gas valve.	36
	16.9 To remove the switch and wiring loom.	36

INSTALLER GUIDE

1. SAFETY

Installer

Before continuing any further with the installation of this appliance please read the following guide to manual handling:

- The lifting weight of this appliance is as below

<u>Model</u>	<u>Heat Engine (kg)</u>	<u>Fascia / Firefront (kg)</u>	<u>Combined Weight (kg)</u>
Decadent	12.58	4.75	17.33
Chic	12.58	3.65	16.23

- One person should be sufficient to lift the fire. If for any reason this weight is considered too heavy then obtain assistance.
- When lifting always keep your back straight. Bend your legs and not your back.
- Avoid twisting at the waist. It is better to reposition your feet.
- Avoid upper body/top heavy bending. Do not lean forward or sideways whilst handling the fire.
- Always grip with the palm of the hand. Do not use the tips of fingers for support.
- Always keep the fire as close to the body as possible. This will minimise the cantilever action.
- Use gloves to provide additional grip.
- Always use assistance if required.

2. APPLIANCE DATA

This product uses a fuel effect, a burner compartment rear wall and gaskets containing Refractory Ceramic Fibres (RCF), which are man-made vitreous silicate fibres. Excessive exposure to these materials may cause irritation to eyes, skin and respiratory tract. Consequently, it is important to take care when handling these articles to ensure that the release of dust is kept to a minimum. To ensure that the release of fibres from these RCF articles is kept to a minimum, during installation and servicing we recommend that you use a HEPA filtered vacuum to remove any dust and soot accumulated in and around the fire before and after working on the fire. When replacing these articles we recommend that the replaced items are not broken up, but are sealed within a heavy duty polythene bag, clearly labelled as RCF waste. This is not classified as “hazardous waste” and may be disposed of at a tipping site licensed for the disposal of industrial waste. Protective clothing is not required when handling these articles, but we recommend you follow the normal hygiene rules of not smoking, eating or drinking in the work area and always wash your hands before eating or drinking. This appliance does

INSTALLER GUIDE

not contain any component manufactured from asbestos or asbestos related products.

Gas	Natural
Inlet pressure	20mbar
Input - Max. (Gross)	3.65kW (12,454 Btu/h)
Input - Min. (Gross)	1.5kW (5,118 Btu/h)
Inlet pressure (Cold)	20.0 ± 1.0mbar (8.0 ± 0.4in w.g.)
Gas connection	8mm pipe
Main burner	Simplex aerated
Burner injector	Bray Cat. 92 size 280
Pilot unit	Left side of firebox. Combined pilot jet, thermocouple sensor and electrode. SIT ref. NGOP9706
Ignition	Integral piezo on gas valve.
Aeration adjustment	None required
Controls	Manual pilot and main burner off/on control (Right control). Separate variable control (Left control) for main burner can be operated by its control knob or from the high level rocker switch. Fitted with flame supervision device and integral piezo igniter
Batteries	4 x 1.5V AA
Walls	Minimum 102mm (4in.) thick. Maximum 660mm (26in.) thick.

The appliance data label is located on a plate at the base of the fire. This can be seen by removing the lower firefront / firefront casting.

This appliance must not be recessed into a combustible wall.

INSTALLER GUIDE

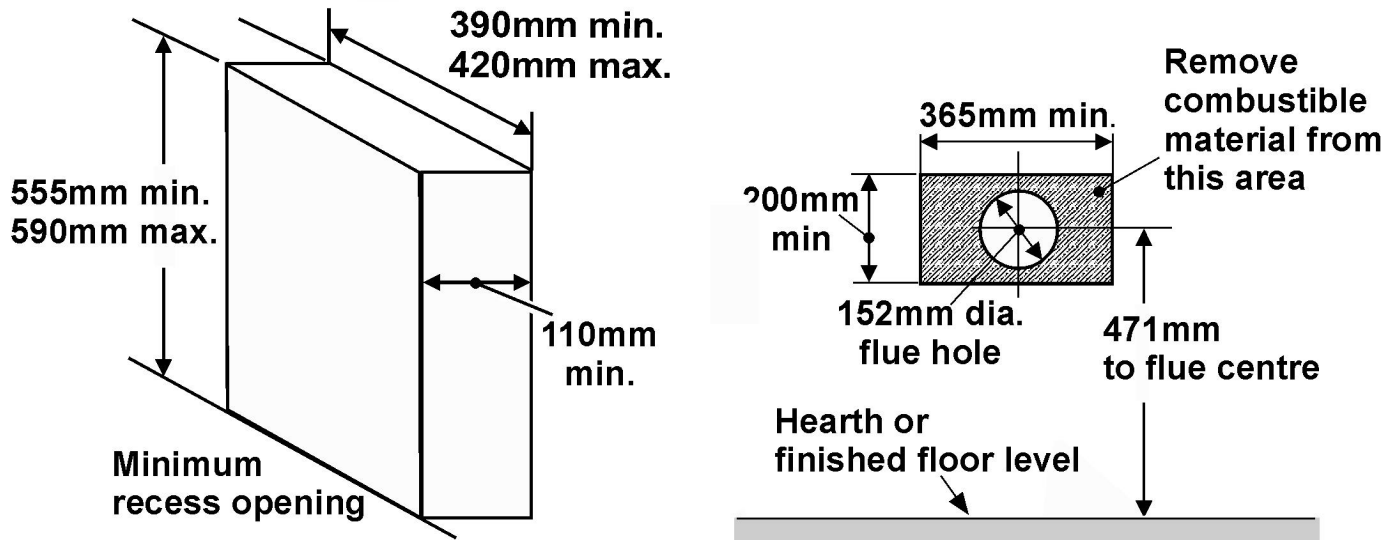
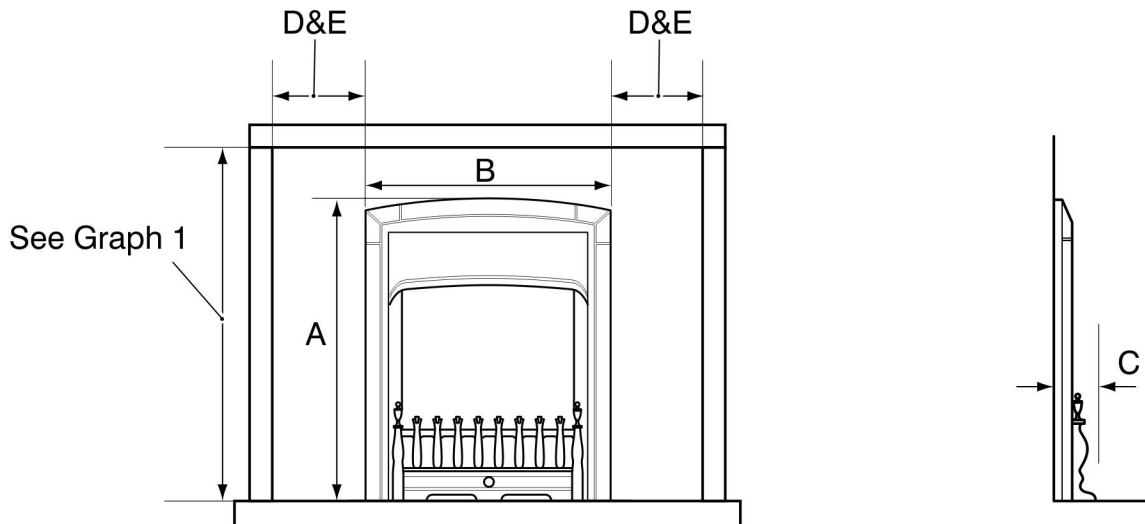

Figure 1. Recess and flue hole dimensions



Key	Description	Model	
		Chic	Decadent
A	Appliance height (mm)	609	607
B	Appliance width (mm)	482	487
C	Appliance depth into room (mm)	104	133
D	Minimum mandatory clearance to combustible surfaces projecting beyond the front of appliance (mm).	102	102
E	Recommended clearance to non-combustible surfaces for access purposes (mm).	51	51

Figure 2. Appliance dimensions and clearances (Fire dimensions are subject to manufacturing deviation)

INSTALLER GUIDE

3. LIST OF AVAILABLE KITS

Description	Part number
● Spacer kit (5 inch)	0595121
● Spacer kit (3 inch)	0595131
● Timber frame Flue Clearance kit.	0583141

This kit includes : -

- 1 off Insulation for rear of fire
- 1 off Flue clearance sleeve
- 1 off Drip collar
- 1 off External wall plate

Under no circumstances is the fire to be recessed into Timber frame constructions. For timber framed installations see section 7.

4. GENERAL INSTALLATION REQUIREMENTS

4.1 The appliance can be installed into the following :-

- A minimum 4.5in rebate surround or 5in. spacer kit Part No 0595121. Where either of these are mounted to a combustible wall make sure that there is no combustible material or combustible cladding in the area indicated on the wall fixing template.
- A 2in rebate surround in conjunction with the 3in. spacer kit Part No 0595131. Where the surround is mounted to a combustible wall make sure that there is no combustible material or combustible cladding in the area indicated on the wall-fixing template.
- Recessed into a builder's opening or cavity of a non- combustible wall. The minimum cavity size is shown in figure 1. A lintel may be required above the recess opening. If in doubt seek expert building advice. Lintel construction details are given in section 7 of this guide. **This appliance must not be recessed into a combustible wall.**

4.2 Note that soft wall coverings (e.g. embossed vinyl etc.) are easily affected by heat. They may therefore, scorch or become discoloured when close to a heating appliance. Please bear this in mind when installing.

4.3 Installation to a timber-framed building should be in accordance with the relevant sections of The Institute of Gas Engineers publication IGE/UP/7 "Gas installations in timber frame buildings".

Please note that advice should be sought before installing in a timber frame building since the alterations required may nullify any NHBC cover relating to the property. If in doubt, guidance should be requested from your local authority planning or building

INSTALLER GUIDE

department.

Under no circumstances is the fire to be recessed into Timber frame constructions. For timber framed installations see section 7.

4.4 The installation must be in accordance with this guide.

For the user's protection, in the United Kingdom it is the law that all gas appliances are installed by competent persons in accordance with the current edition of the Gas Safety (Installation and Use) Regulations. Failure to install the appliance correctly could lead to prosecution. The Council for the Registration of Gas Installers (CORGI) requires its members to work to recognised standards.

In the United Kingdom the installation must also be in accordance with:

All the relevant parts of local regulations.

The current edition of the Building Regulations issued by the Department of the Environment and the Welsh Office, the Building Standards (Scotland) (Consolidation) Regulations issued by the Scottish Development Department or the Building Regulations (Northern Ireland) issued by the Department of the Environment for Northern Ireland.

All relevant codes of practice.

The relevant parts of the current editions of the following British Standards:-

BS 5440 Part 1

BS 5871 Part 1

BS 6891

In the republic of Ireland the installation must also conform to:

- a) The relevant parts of the current edition of IS 813 "Domestic Gas Installations"
- b) All applicable national and local rules in force.

Where no specific instructions are given, reference should be made to the relevant British Standard Code of Practice.

4.5 A minimum clearance of 51mm should be maintained at each side of the fire for servicing access.

Any combustible side wall or other combustible projection must be at least 102mm clear from direct exposure to the radiant surface of the appliance unless suitably protected.

4.6 The minimum height from the base of the fire to the underside of any shelf made from wood or other combustible materials is as follows:-

- *For a shelf up to 150mm deep*
Minimum height = 780mm.
- *For a shelf deeper than 150mm*
780mm + 12.5mm for every 25mm depth over 150mm.

(See graph 1)

INSTALLER GUIDE

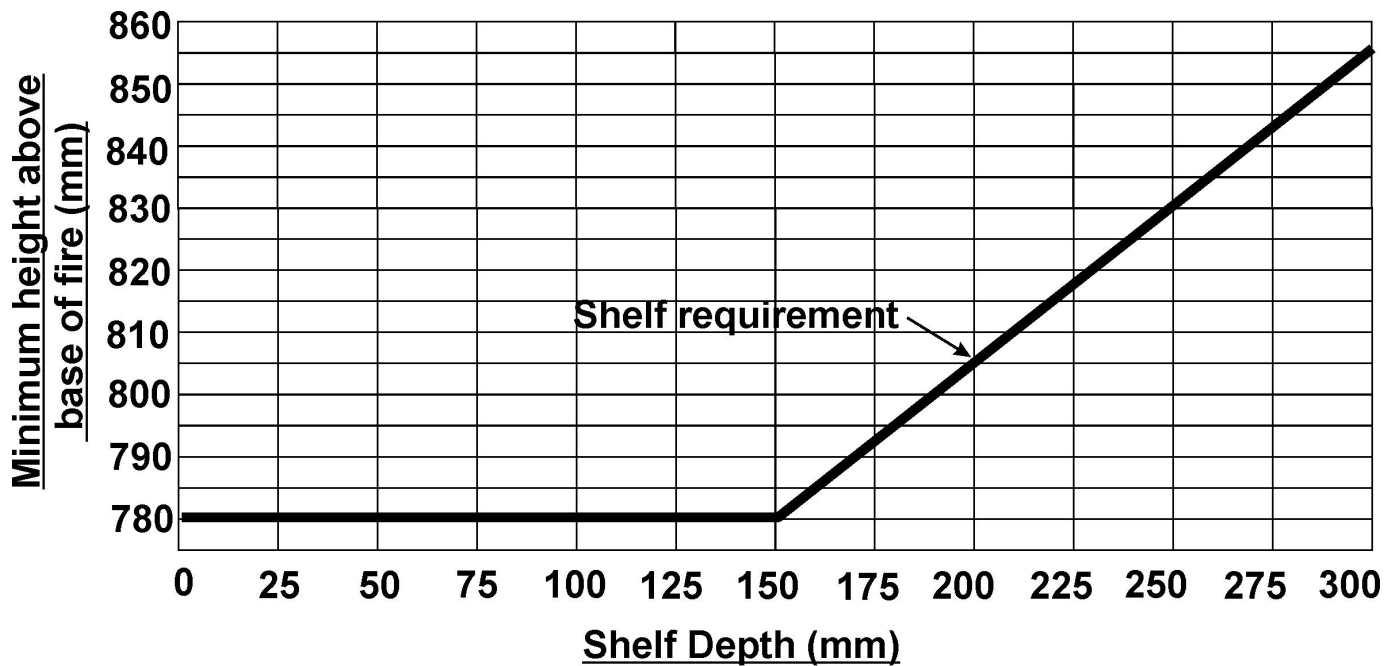

Graph 1. Combustible shelf clearances.

There is no restriction on the position or depth of non-combustible projections for all normal installations. Installation into an unusually tightly restricted recess, however, could cause the temperature of the appliance surfaces to become unacceptably high.

4.7 It is advisable that combustible fabrics such as curtains are not fitted above the fire. If, however, this is unavoidable, the extreme bottom edge of the fabric must be at least 780mm above the base of the fire.

4.8 This appliance does not require a non-combustible hearth. It can be installed on any hard surface. This surface should be level and sufficiently flat to enable the bottom of the fascia / firefront casting to be aligned horizontally. Any unevenness (Uneven tiles, Cotswold stone etc.) should be rectified.

The appliance must not stand on carpet or other textured surfaces which may interfere with the flow of convection air through the bottom of the appliance. The floor surface that must be free of carpets, rugs or other fabric coverings should be at least as wide as the appliance fascia and project forward at least 300mm from the rear wall. In order to prevent carpet etc. being placed within this area, we strongly recommend that the appliance is installed on a raised hearth or that the periphery of this area is bordered by a fender.

4.9 The appliance must not stand on combustible materials or carpets.

INSTALLER GUIDE

4.10 A hole 152mm (6in) dia. is required through the wall for the flue unit. The height of the hole centre is shown in figure 1 and on the wall-fixing template supplied with the appliance.

4.11 This appliance has exposed battery and electric motor components. It is not recommended, therefore, that it be used in rooms which contains a bath, shower or where steam is regularly present due to the possibility of corrosion or electrical shorting.

4.12 A concealed gas supply connection can be made through the rear left panel. Visible front connection can be from the left or right side.

4.13 No special ventilation bricks or vents into the room containing the appliance are required.

4.14 A terminal guard is supplied with this appliance.

In England and Wales the Building Regulations require a terminal guard to be fitted if the terminal could come into contact with people near the building or be subject to damage.

In the republic of Ireland the installation must also conform to the relevant parts of the current edition of IS 813 “Domestic Gas Installations”

We recommend that the guard is fitted where contact with or damage to the terminal is possible even if regulations do not demand it.

4.15 Combustible cladding.

Decadent model.

If the fire is to be fitted against a wall with combustible cladding, the cladding must be removed from the area shown in figure 3.

Chic model.

If the fire is to be fitted against a wall with combustible cladding, the cladding must be removed from behind fire and must have a minimum clearance of 5mm from the fascia / outside of the appliance.

4.16 Minimum allowable distances from the terminal are shown in figures 4a and 4b.

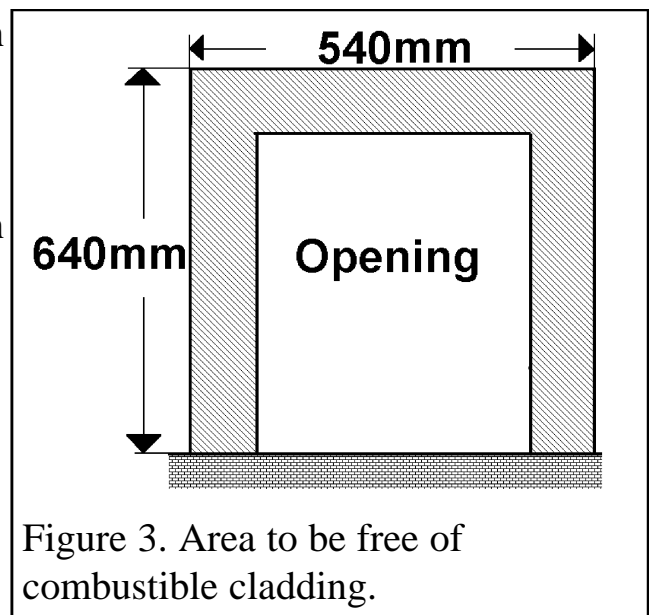

INSTALLER GUIDE

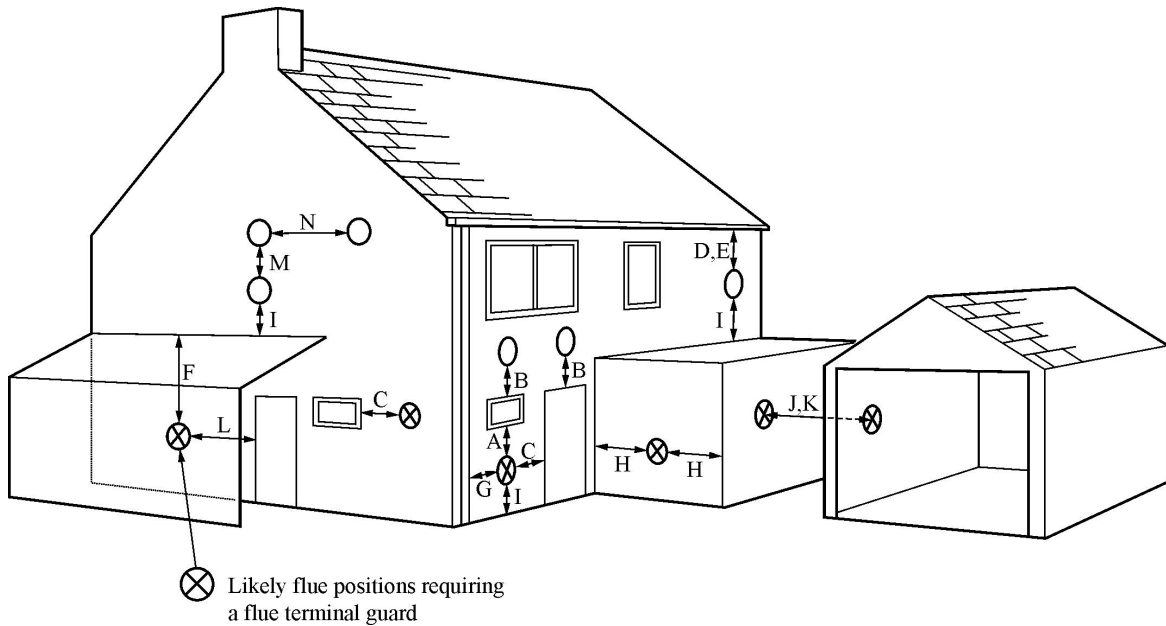

Key	Terminal position	Minimum distance (mm)
A*	Directly below an opening, air brick, opening window etc.	300mm
B*	Above an opening, air brick, opening window etc.	300mm
C*	Horizontally to an opening, air brick, opening window etc.	300mm
D	Below gutters, soil pipes or drain pipes.	300mm
E	Below eaves.	300mm
F	Below balconies or car port roof.	600mm
G	From a vertical drain pipe or soil pipe.	300mm
H**	From an internal or external corner.	600mm
I	Above ground, roof or balcony level.	300mm
J	From a surface facing the terminal.	600mm
K	From a terminal facing the terminal.	600mm
L	From an opening in a car port (e.g. door, window) into dwelling.	1200mm
M	Vertically from a terminal on the same wall.	1500mm
N	Horizontally from a terminal on the same wall.	300mm

Figure 4a.

*In addition, the terminal should not be nearer than 300mm to an opening in the building fabric formed for the purpose of accommodating a built-in element such as a window frame or door frame (See figure 4b).

** The reference to external corners does not apply to building protrusions not exceeding 450mm, such as disused chimneys on external walls.

INSTALLER GUIDE

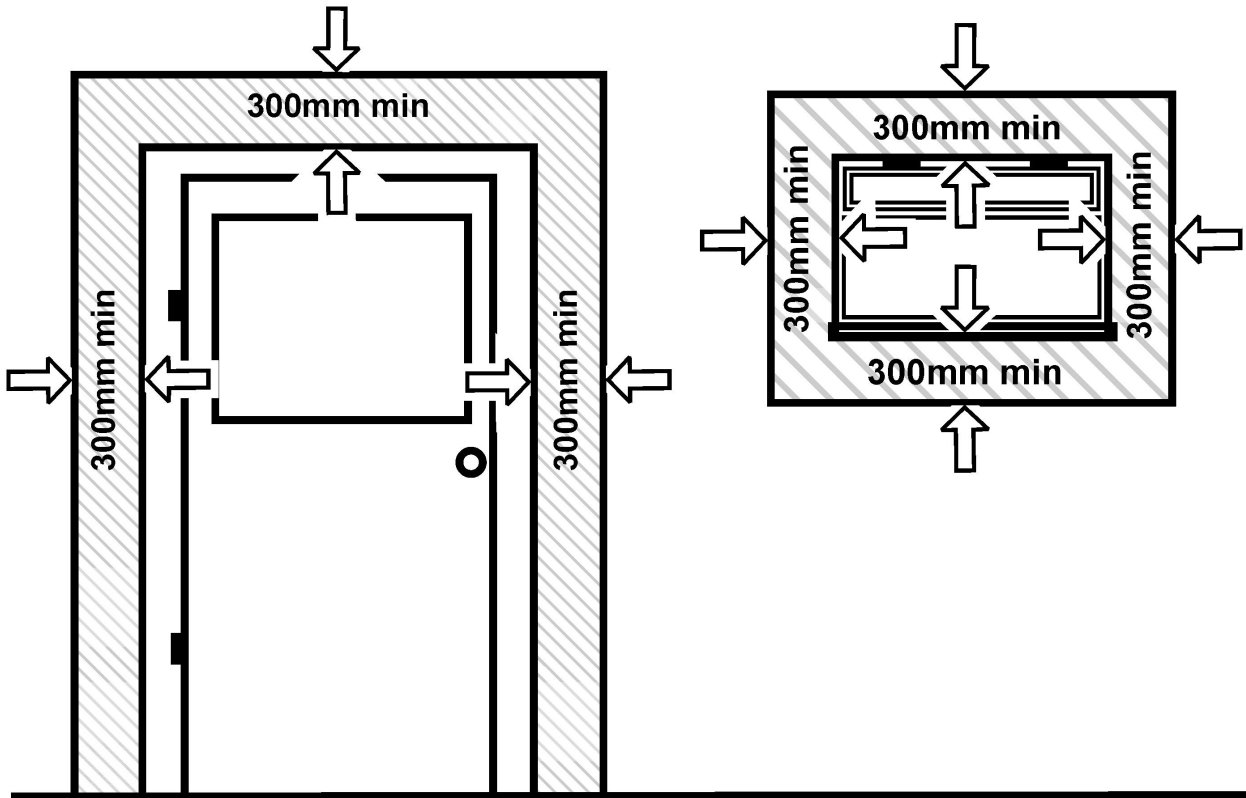

Figure 4b.

5. UNPACKING AND PRELIMINARY CHECKS

5.1 Unpacking.

- | | |
|--|----------------------------------|
| 1 Main fire assembly | 2 Fibre wall plugs |
| 1 Fascia (Attached to fire on the Decadent model) | 2 No 6 tapping screws |
| 1 Ceramic fuel effect (Packed in the fire) | 8 Woodscrews |
| 1 Nut & olive for 8mm inlet pipe | 8 Plastic wall plugs |
| 1 Front casting and ash pan pack (Decadent model only) | 1 Length of flue sealing tape |
| 1 Flue unit | 1 Literature pack |
| 1 Wall fixing template | 4 Batteries 1.5V AA |
| 2 Fire retaining cables | 1 Terminal guard (supplied flat) |
| | 2 Eyebolts |

INSTALLER GUIDE

5.2 Appliance disassembly.

5.2.1 Fascia removal on the Decadent model (See figure 5).

- Remove the two screws securing the bottom of the fascia to the sides of the convection box.
- Raise the fascia to allow the retaining lugs at the top to clear the slots in the convection box hood and then lift clear.
- Place the fascia in a safe place away from your immediate work area.

5.2.2 Window and ceramic fuel effect removal (Both models).

- Unscrew and remove the three spring loaded window fixing screws and washers from the base of the window frame (See figure 6). Keep the screws and washers in a safe place.

- Gently swing the base of the window frame forward while lifting the frame upward. The window should lift clear of the fire. Put the window in a safe place away from your immediate work area.

- Carefully remove the ceramic fuel effect in its packaging. The ceramic fuel effect base is a single piece. The individual ceramic pieces are packed separately. Put them in a safe place away from your immediate work area.

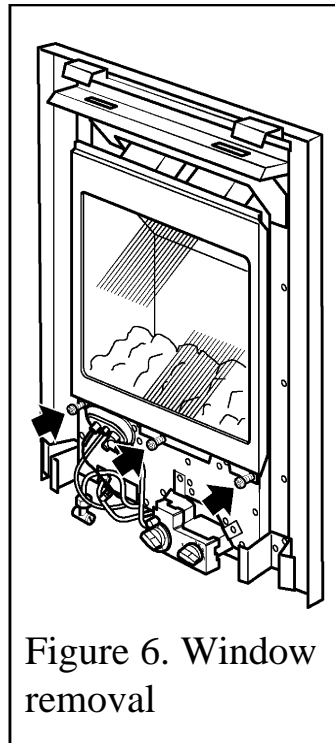

Figure 6. Window removal

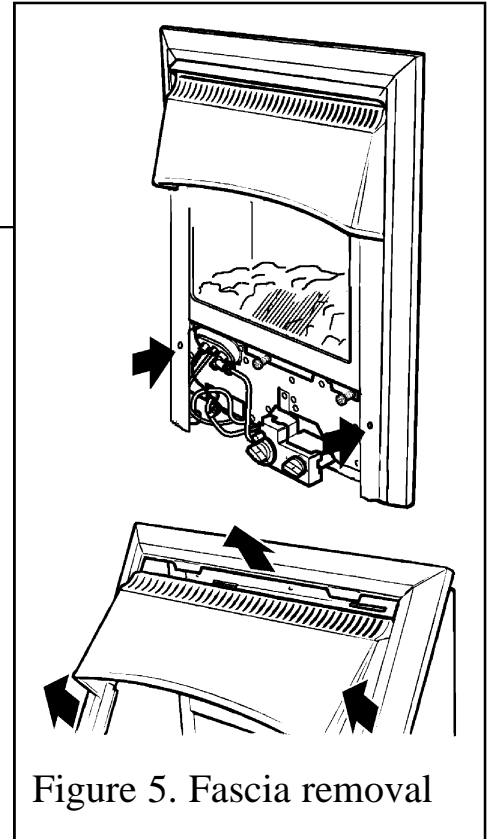

Figure 5. Fascia removal

5.3 Preliminary checks.

5.3.1 Check ignition spark.

The pilot burner and electrode unit is at the left front corner of the burner.

- Push in the right hand control knob and turn anticlockwise through the ignition position marked



and up to the pilot position marked



A spark should flash across from the pilot electrode to the pilot burner hood. If there is no spark, check that the spark gap is as shown in figure 7.

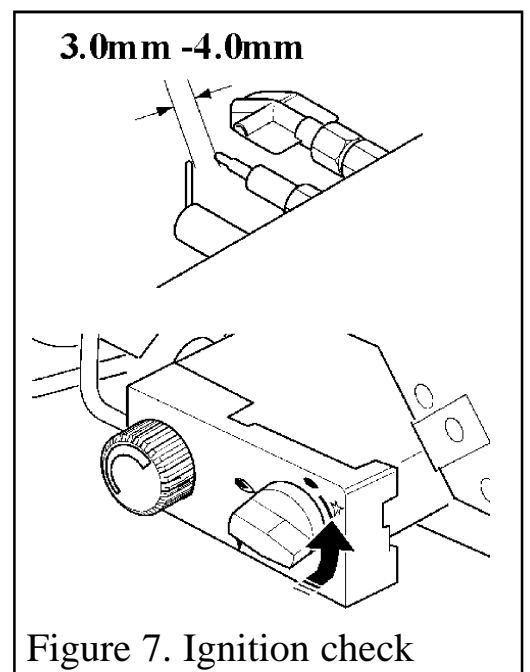

Figure 7. Ignition check

INSTALLER GUIDE

5.3.2 Check flame control motor.

(See figure 8)

- Lift the plastic battery holder out of its metal support situated at the lower right corner.
- Fit the four 1.5V batteries and replace the battery holder.
- Place the fascia in front of the fire and connect the battery and motor leads. The motor lead connectors are two different sizes. They will only fit to the correct motor terminals.

- Depress the top half of the rocker switch located at the right side of the appliance case.

This should cause the flame control knob (The left-hand control knob) to rotate

anticlockwise until it is vertical. Depressing the bottom half of the rocker switch should then cause the knob to rotate almost 180° clockwise. A clicking sound will be heard while the flame control knob is rotating.

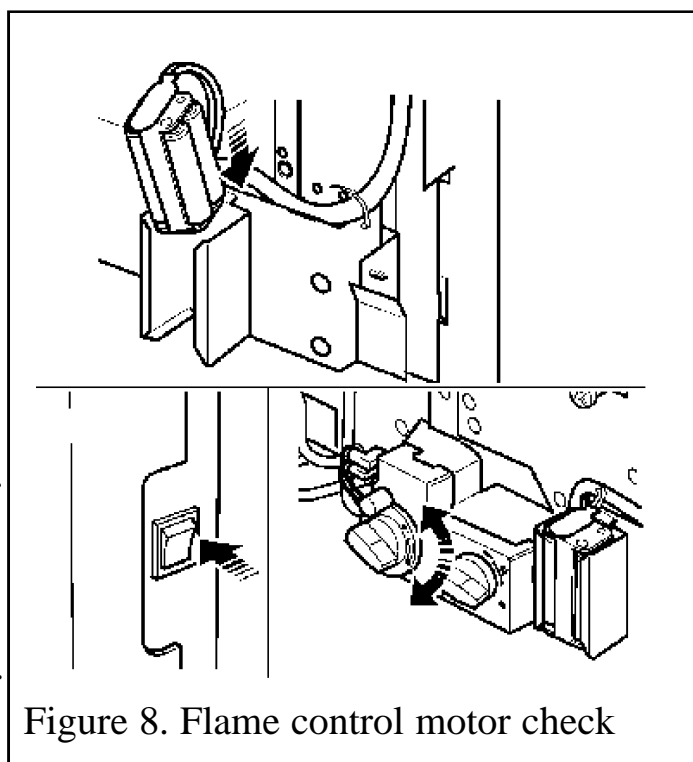

Figure 8. Flame control motor check

6. GAS SUPPLY CONNECTION

A nut & olive are provided for an 8mm pipe inlet connection to the inlet 'T' connector at the bottom front of the appliance. This can be rotated to allow a connection from any direction and includes a valve for isolating the gas supply.

The supply pipe must be rigid material. Flexible pipe must not be used.

Concealed supply pipe connecting from rear of the appliance.

Before the appliance is installed it will be necessary to extend the supply line so that it will project through the sealed opening at the back of the fire case and run to the inlet 'T' connector at the front.

Make sure that the supply line run up to the rear opening is kept away from the area that will be taken by the appliance case when it is installed.

Note that when fitted the centre of the appliance inlet 'T' connector is 25mm above the floor.

Cut a slit in the seal at the back of the appliance case. The seal must envelop the pipe.

Do not slit the seal unless the supply pipe is to pass through it.

Cap the open end of any supply pipe installed before the wall is drilled to prevent any debris or dust etc. entering the pipe.

INSTALLER GUIDE

7. WALL PREPARATION

7.1 Select appliance position.

The flue must be installed so that it is at right angles to the back panel of the fire all round the flue circumference.

For timber framed buildings make sure that the flue opening will be between studs. When being recessed into a non-combustible wall or builders opening the fire itself should be fitted vertically against a flat wall. Where this is difficult to achieve due to building inaccuracies care should be taken to ensure that the back of the fire is not stressed in any way due to distortion of the appliance when tightening the fixing screws. Where necessary, non-combustible packing pieces should be used to provide a satisfactory fixing surface.

7.2 Constructing a recessed opening.

Under no circumstances is the fire to be recessed into timber frame constructions or any other combustible wall.

The recess in the wall for the appliance should be within the sizes shown in figure 1. The bottom of the recess should be at the same level as the finished floor in front of the appliance.

A lintel may be required above the recess for the convection box. If in doubt, seek expert building advice before commencing to cut the recess.

7.2.1 Fitting a lintel.

Whenever a lintel is required to support the recess in the inner leaf of a brick/blockwork building, follow the method outlined below (See figure 9).

- The lintel should be either steel (Catnic) or reinforced precast concrete. It should be 750mm long x 75mm deep x inner leaf thickness.
- The opening should be, as near as possible, centrally below a joint in the inner leaf block.
- Cut out the opening for the lintel.
- Where cutting through masonry, drill pilot holes and then cut out the slot using a mechanical cutter. This will minimise damage to the surrounding structure.

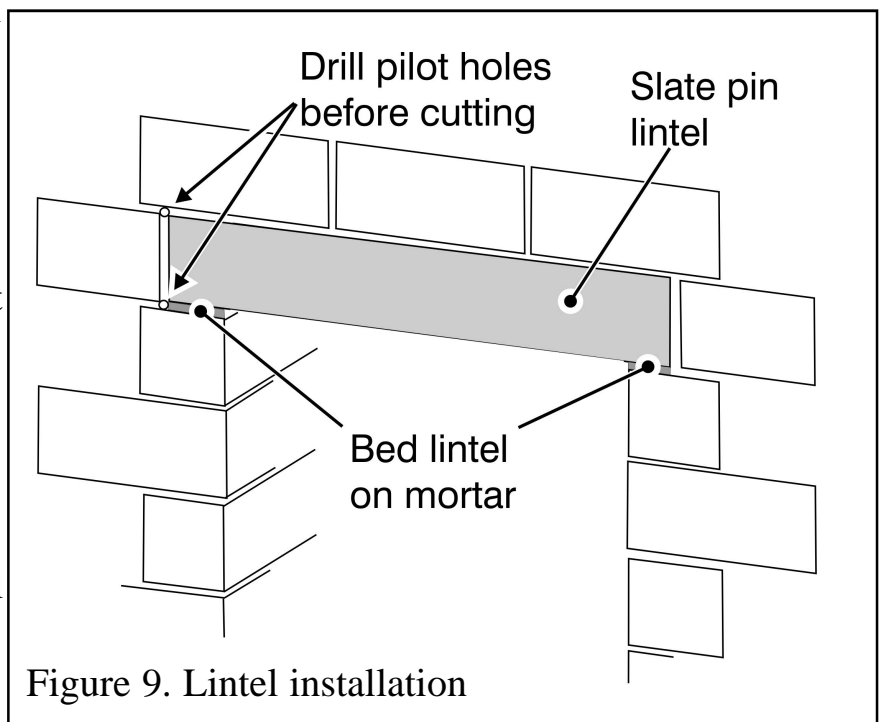

INSTALLER GUIDE

- Insert the lintel. Bed the lintel on mortar. Don't dry bed. Slate pin to ensure the lintel and structure above is secure and safe
- Make the opening below the lintel by removing the masonry and clearing debris. If the cavity has loose fill (e.g. granular) insulation material, pack the edges of the opening with Rockwool as you proceed to hold back the insulating material.

7.2.2 Preparing a wall cavity.

- The wall cavity must not be bridged other than by the flue unit. The appliance case must not project into the cavity between the inner and outer walls by more than 10mm.
- The cavity should be sealed where the opening has been cut. We recommend filling fully across the cavity with Rockwool or equivalent to at least 100mm above and each side of the recess opening (See figure 10).
- An alternative to rockwool **above** the opening is to seal across the top of the cavity with superlux board or equivalent. The board should slope downward to the back so that any moisture will be channelled to the outside (See figure 10).

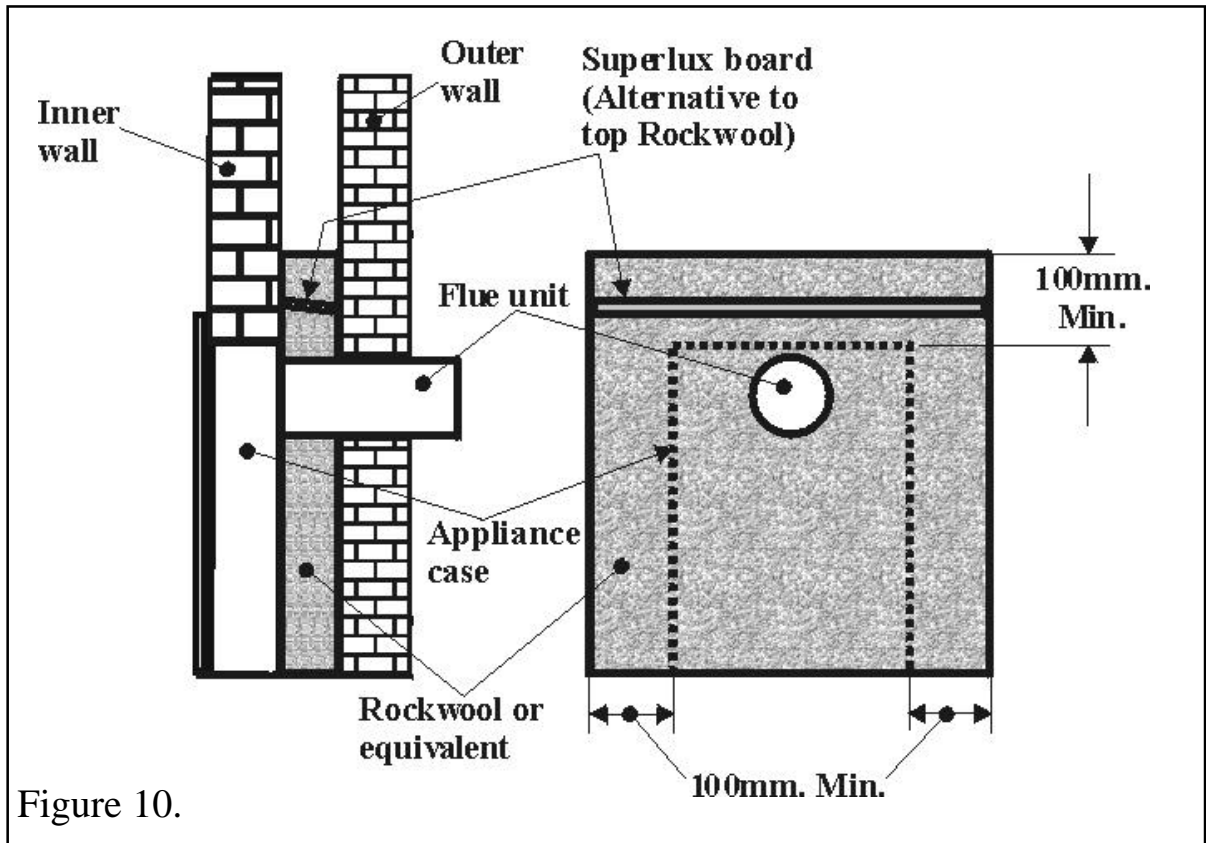

7.3 Combustible wall materials.

- For brick or other non-combustible wall constructions, be sure to remove any combustible wall cladding material from the area shown in figure 1.
- For Timber frame buildings, the back surface of the appliance case must be separated from the timber frame by 25mm of non-combustible material. This can consist of the usual 12.5mm thick plasterboard plus a 12.5mm thick sheet of non-combustible insulating material (e.g. fibre cement board). A Timber frame flue clearance kit is available. Part no. 0583141. This contains a pre-cut insulating sheet. The insulating

INSTALLER GUIDE

sheet can be used to seal the annular gap between the flue unit and the inner leaf sleeve - see section 7.5. Do not permanently fix the insulating sheet to the wall at this stage - see section 8.2.

7.4 Cutting the flue hole for brick, stone etc. building.

Cut the hole for the flue unit. Make sure that it is straight and level. Though a hammer and chisel can be used, using a core drill is by far the quickest and simplest method for normal brick work.

- Before cutting the hole in the wall make sure that the height to the top surface of the finished floor or hearth is known. The height from this surface to the flue hole centre is shown in figure 1. The terminal position must also comply with the location requirements given in section 4.15.
- Place dust sheets on the floor and over any furnishings etc.
- Place the template against the wall. Make sure that the centre of the flue hole is as shown in figure 1.
- Pierce the template at the centre of the screw fixing holes and the flue hole and mark the positions on the wall. Remove the template.

7.4.1 Core drilling.

- Drill a pilot hole through the wall. Inspect the hole to ensure that it is in the brick work and not in mortar. If it is in mortar, it is advisable to reposition the hole approximately 25mm away - Make sure that the minimum side clearances and height are complied with. Remember to reposition the screw fixing holes.
- Drill the flue hole with a 152mm (6in) core drill. Where practical, it is recommended that the hole is drilled from inside the building to about half the wall depth with the remainder drilled from outside. This ensures that the edges of the hole are clean on both sides.

7.4.2 Hammer and chisel cutting.

- Mark a 152mm (6in) diameter circle for the flue hole. Chisel out the area marked.
- It may be necessary to make good both the internal and external wall faces. To achieve a neat finish and to make any future removal of the flue unit easier, it is recommended that a cardboard cylinder is formed around the flue unit and inserted in the hole while making good. Remove the cardboard cylinder after making good.

7.4.3 Leaving a hole for a building under construction.

- It will be convenient to use a non-corrosive metal tube 160mm diameter built into the wall at the correct position for the flue unit.

7.5 Cutting the flue hole in timber frame buildings.

Drill the pilot hole and hole in outer wall as section 7.4.

- Since the flue will pass through combustible material in the inner leaf of the wall, a

INSTALLER GUIDE

non-combustible sleeve 203mm (8in.) diameter will be required round the flue (See figure 11).

- Cut a hole through the inner leaf to accommodate a non-combustible sleeve 203mm (8in.) outside diameter. To minimise the effect of breaking through the vapour control layer (VCL), if possible, cut the hole approximately 10mm undersize so that the sleeve will be forced through the layer. A recommended technique for cutting the inner leaf is shown in figure 11.
- Fit the non-combustible sleeve to the inner leaf. The sleeve must extend to be at least flush with the breather membrane/timber sheathing but must not protrude more than 10mm into the cavity.
- The annular gap between the flue unit and the sleeve must be sealed to prevent air heat and moisture passing along it. The 12.5mm insulating sheet (See section 7.3) can be used for this. Do not permanently fix the insulating sheet to the wall at this stage (See section 8.2).

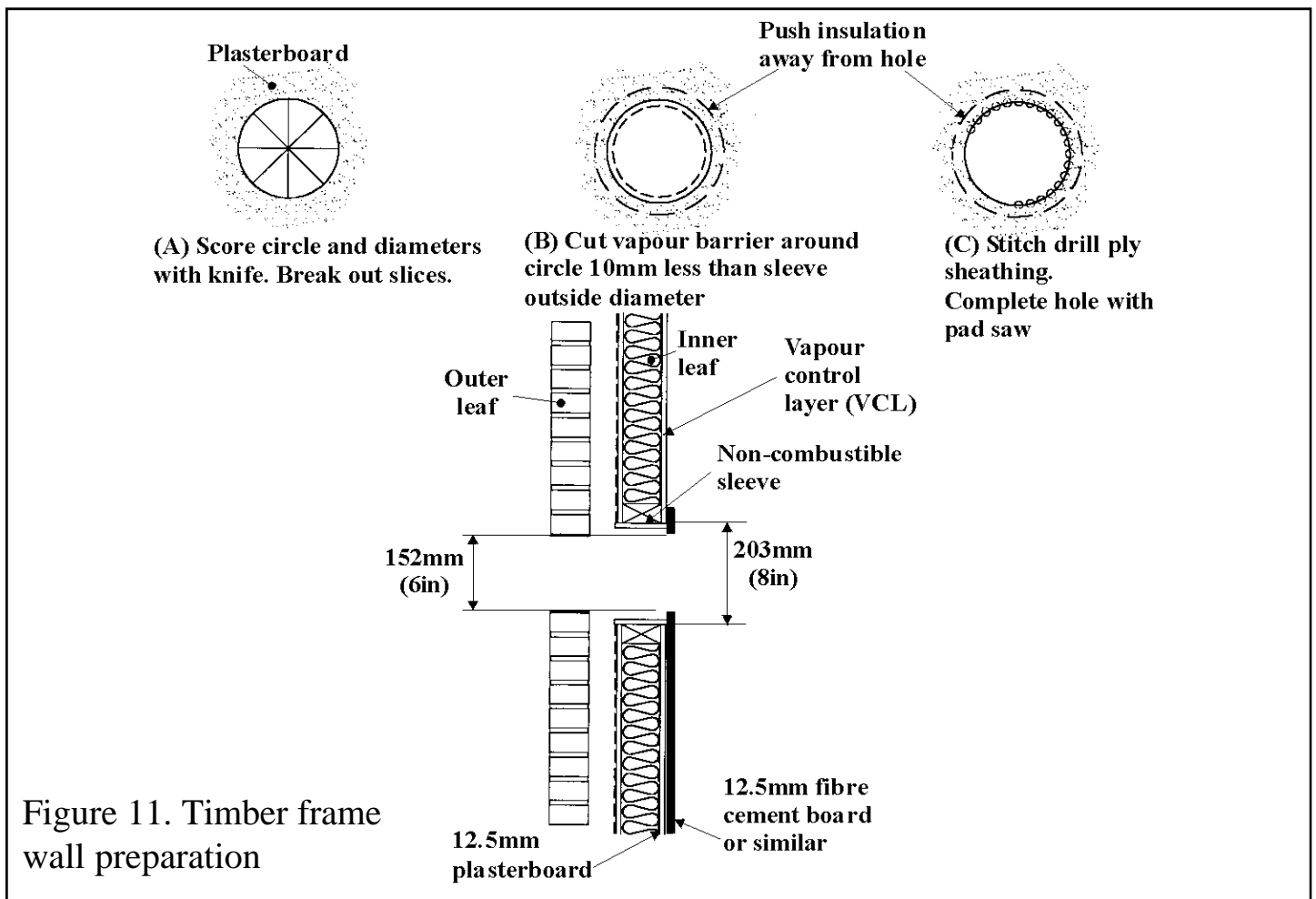

7.6 Prepare appliance fixing holes.

7.6.1 Screwing case to wall.

- Recheck the position of the screw fixing holes relative to the flue hole.
- Drill the four fixing holes to a minimum depth of 42mm using a 7mm diameter masonry drill.

INSTALLER GUIDE

- Insert four plastic wall plugs supplied.

7.6.2 Using cable retention.

- Thread the two tension cables through the appliance case side holes as shown in figure 12.
- Move the appliance towards the recess and mark on the recess back wall the position for the two eyebolt holes.
- Remove the appliance and drill at the marked positions using a no.12 masonry drill.
- Insert the two fibre wall plugs supplied.
- Fit the two eyebolts.

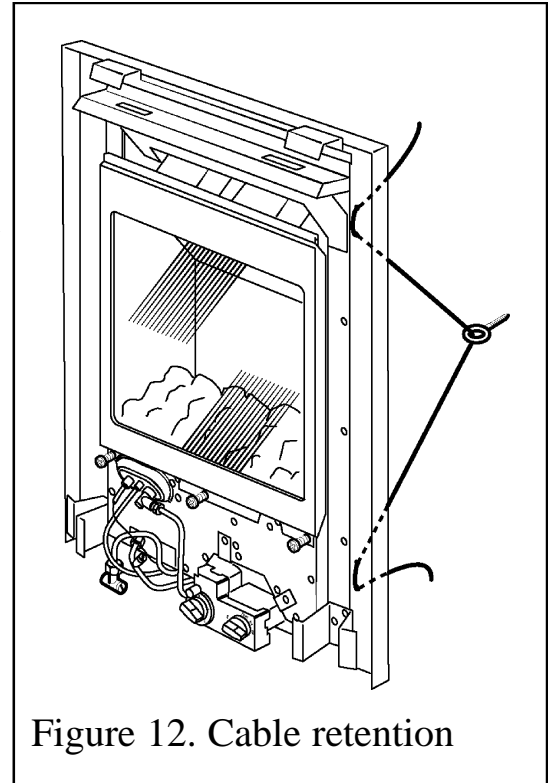

Figure 12. Cable retention

8. FLUE TERMINAL INSTALLATION

8.1 Cutting flue to size.

- For outset appliances with surround or spacer

Measure the total wall thickness from the outside surface of the wall to the inside face of the surround or spacer. Deduct 35mm from this measurement to obtain the correct length of flue unit required (See figures 13a & 13b).

- For appliances inset in a recess

Measure the total finished wall thickness including plaster etc. Deduct 35mm from this measurement to obtain the correct length of flue unit required (See figure 13a).

- Mark off the flue length on the outer (air) tube measuring from the end of the terminal.
- Insert the polystyrene ring between the inner and outer tubes to support them. Cut both tubes squarely at the marked distance. **Important: Remove all polystyrene from the flue unit after cutting.**

INSTALLER GUIDE

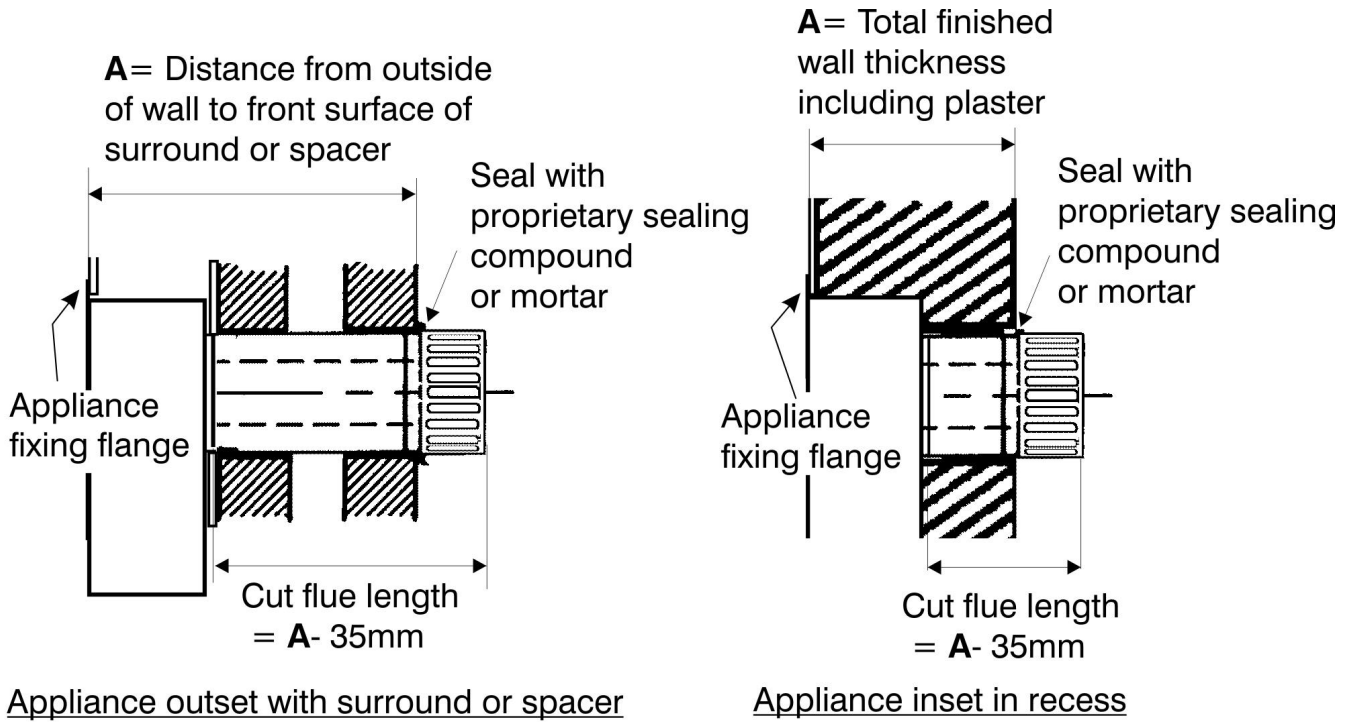

Figure 13a. Flue unit installation - Brick etc. building

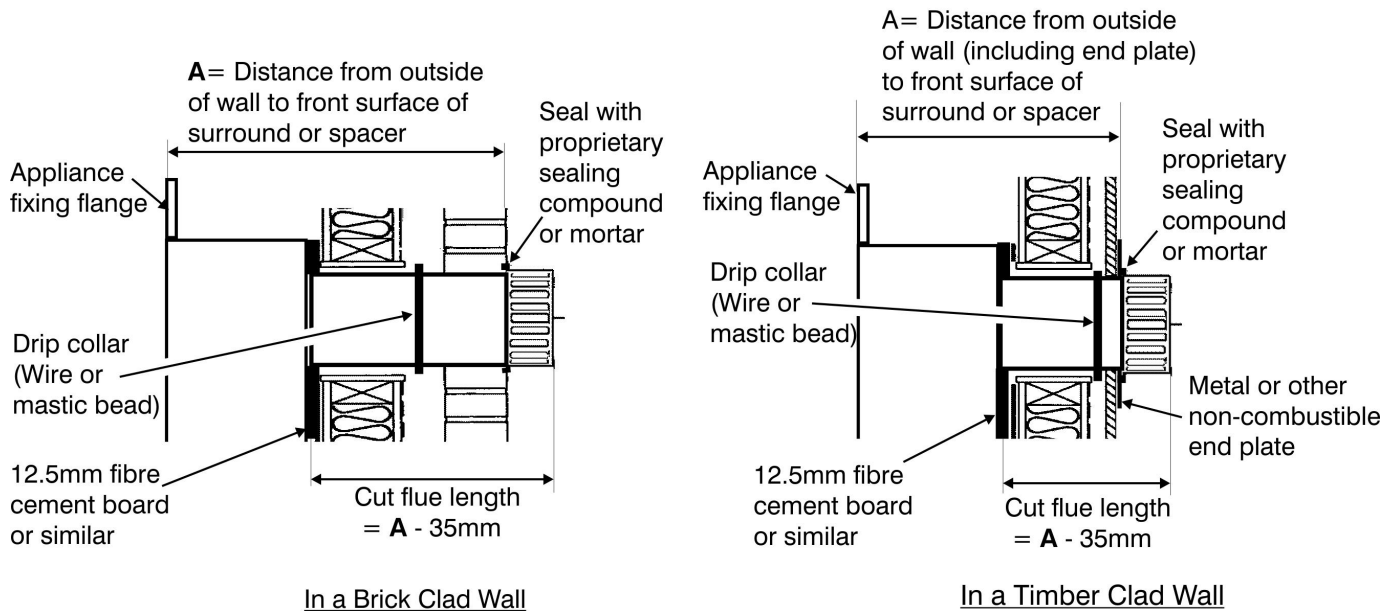

Figure 13b. Flue unit installation - Timber framed building.

INSTALLER GUIDE

8.2 Fitting to wall.

- Fit the flue tubes firmly over the spigots at the rear of the fire. Make sure that the seam on the flue tube is not at the bottom. Push on until the outer (air) tube just covers the slots in the appliance outer spigot (See figure 14).

- Secure the flue to the fire by drilling through the outer flue tube and outer spigot at a distance of between 6mm & 7mm from the cut end of the outer flue tube and securing with the two no.6 self tapping screws supplied (See figure 14).

- Seal the flue unit all round the circumference of the outer spigot with the tape supplied.

- Timber frame buildings: Offer the fire complete with flue unit through the insulating sheet (mentioned in section 7.3). Fit a drip collar round the flue positioned so that it will be located in the centre of the wall cavity (See figure 13b). The drip collar can be made by wrapping a non-corrosive wire round the flue or moulding a bead of mastic round the flue. A timber frame flue clearance kit is available. Part no. 0583141.

- Case fixing to wall: Offer the fire complete with flue unit through the wall, Insert the four fixing screws and tighten.

- Cable retention: Fit the eyebolts onto the cables. Thread the cables through the appliance case sides as shown in figure 12. Offer the fire complete with flue unit through the wall. Pull the cables taut.

- Timber frame building with combustible outer leaf (e.g. shiplap boarding): A metal or other non-combustible end plate must be fitted on the outside of the wall. The plate must be concentric with the flue and at least 254mm (10in) square or diameter (See figure 13b).

- Seal the outer flue tube to the outside surface of the wall with fireclay or cement. Make sure that the slots in the flue terminal are not closer than 8mm to the wall and are not obstructed by cement.

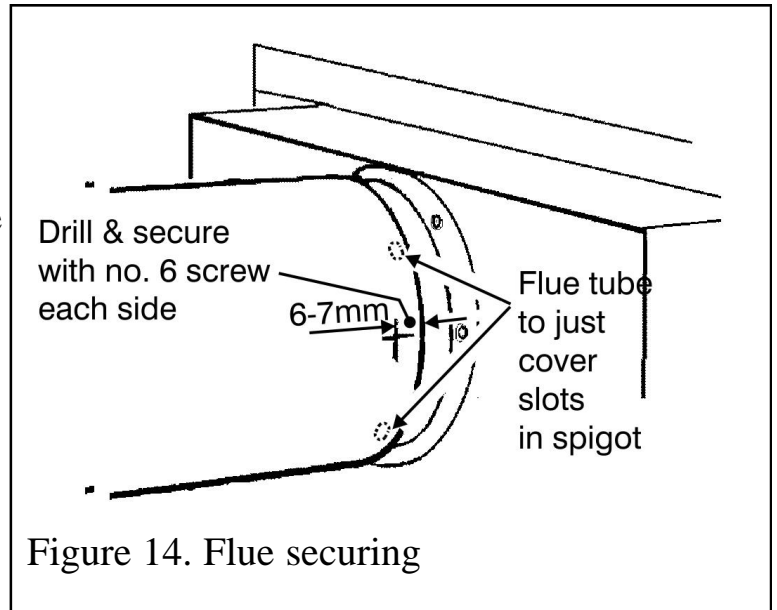
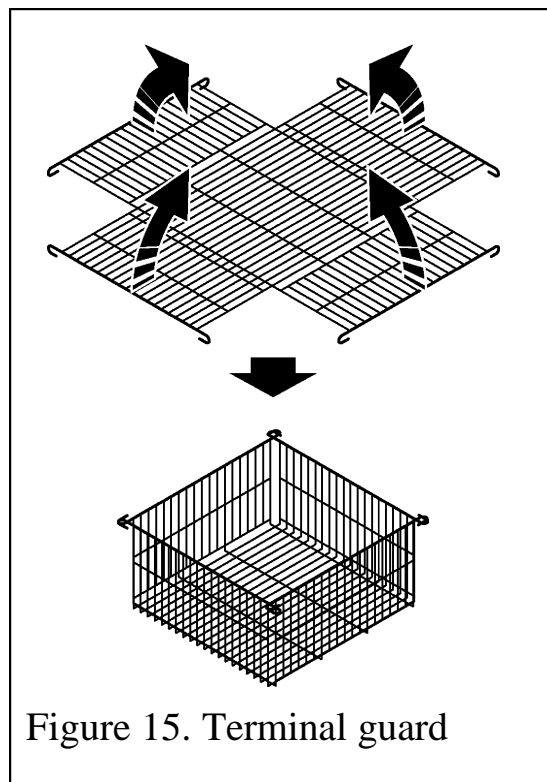

Figure 14. Flue securing

INSTALLER GUIDE

8.3 Fitting the terminal guard.

- Fold the terminal guard as shown in figure 15.
- Place the guard centrally over the flue terminal.
- Holding the guard in position and using it as a template, mark on the wall the positions of the four fixing holes.
- Remove the guard. Drill and plug the holes with the four plugs supplied.
- Replace the guard and refix with four woodscrews supplied.



9. GAS CONNECTION

Connecting the gas supply pipe.

- Complete the supply pipe connection
- For concealed rear connection, the pipe run should have been extended as section 4 of this guide. Connect the inlet 'T' connector to the appliance inlet pipe.
- For Side Connection, the pipe should be routed to pass through a cut-out at the side of the casting or fascia. Where a cut-out is not provided it will be necessary to create one. For right side connection, the pipe should also be formed to clear the control unit. Connect the inlet 'T' connector to the appliance inlet pipe.
- Pressure test the installation pipework for gas soundness in accordance with the current edition of BS 6891.

INSTALLER GUIDE

10. CERAMIC COALS INSTALLATION

This section is for models supplied with a 'Coal' fuel effect only.

For 'Pebble fuel effect' see section 11

10.1 Ceramic coal fuel effect installation for the Decadent model.

The ceramic fuel effect may cause staining / discolouration to decorative surfaces. It is therefore advisable to protect decorative surfaces.

1. Fit the ceramic coal into the fire above the burner. The front of the ceramic coal should locate on the horizontal faces but behind the vertical faces of the two location brackets positioned at the front of the burner module. See figure 16.

The coals should be positioned so that the arrows always point towards the back of the firebox. When located into position the stem of each arrow should be at 90° to the rear of the firebox.

2. Hold coal 'A' upright with the arrow pointing to the top. Locate coal 'A' as shown in figure 17.

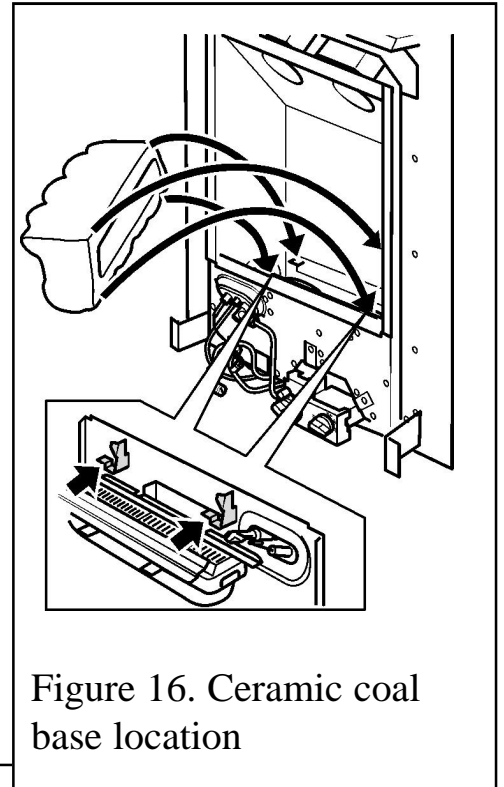

Figure 16. Ceramic coal base location

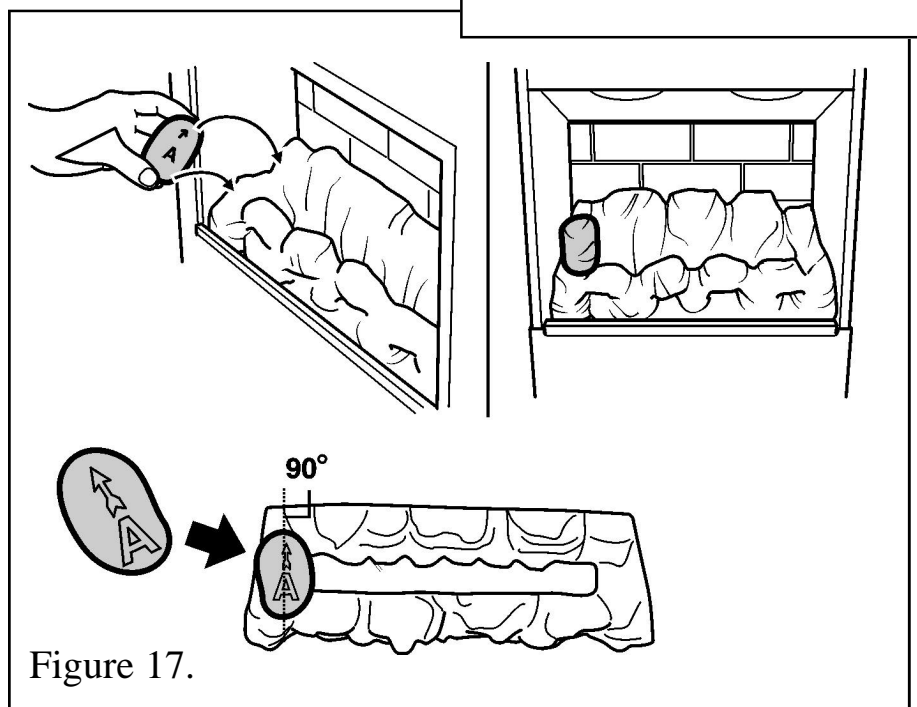

Figure 17.

INSTALLER GUIDE

3. Hold coal 'B' upright with the arrow pointing to the top. Locate coal 'B' as shown in figure 18.



4. Hold coal 'C' upright with the arrow pointing to the top. Locate coal 'C' as shown in figure 19.

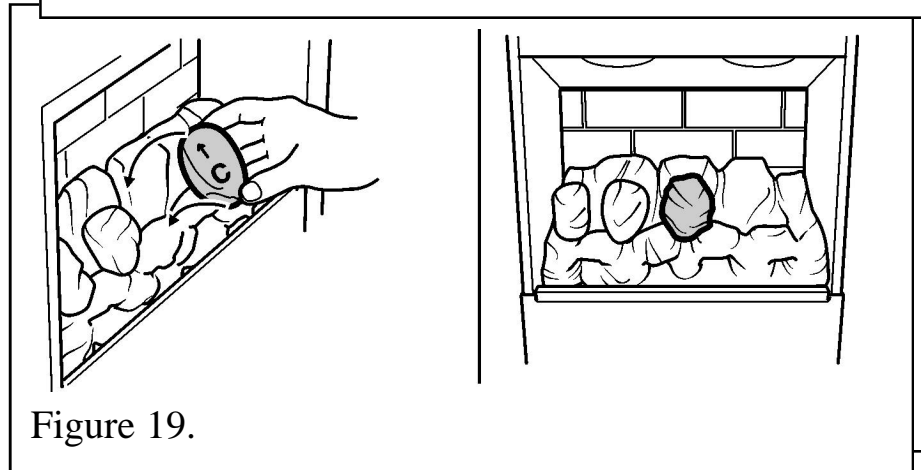

5. Hold coal 'D' upright with the arrow pointing to the top. Locate coal 'D' as shown in figure 20.

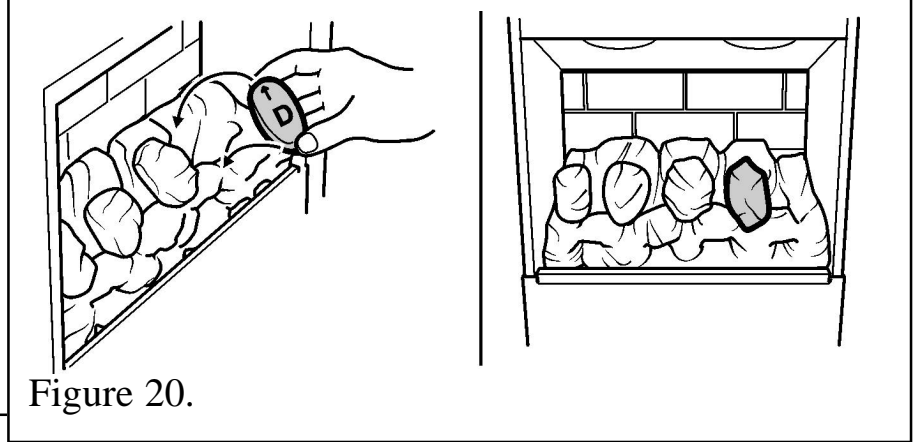

6. Hold coal 'E' upright with the arrow pointing to the top. Locate coal 'E' as shown in figure 21.

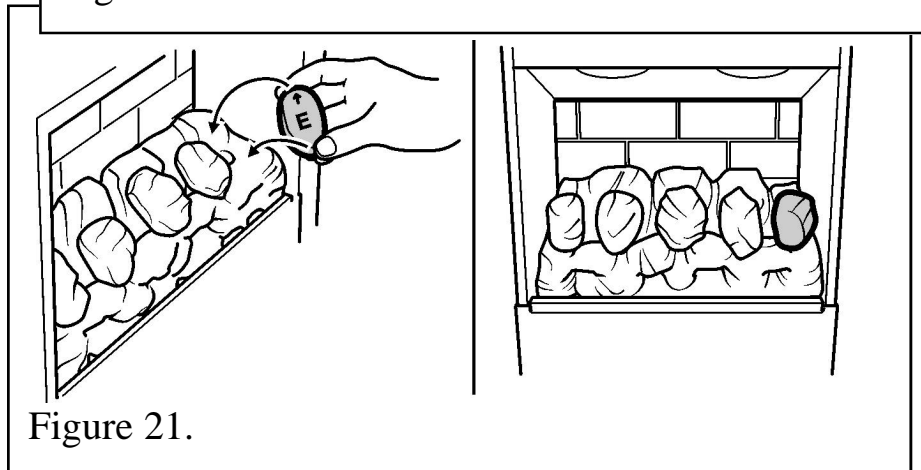

INSTALLER GUIDE

11. CERAMIC PEBBLES INSTALLATION

This section is for models supplied with a 'Pebble' fuel effect only.

For 'Coal fuel effect' see section 10.

11.1 Ceramic Pebble fuel effect installation for Chic model.

The ceramic fuel effect may cause staining / discolouration to decorative surfaces. It is therefore advisable to protect decorative surfaces.

1. Fit the ceramic pebble base into the fire above the burner. The front of the ceramic pebble base should locate on the horizontal faces but behind the vertical faces of the two location brackets positioned at the front of the burner module (See figure 22).

The pebbles should be positioned so that the arrows always point towards the back of the firebox. When located into position the stem of each arrow should be at 90° to the rear of the firebox.

2. Hold pebble 'A' upright with the arrow pointing to the top. Locate pebble 'A' as shown in figure 23.

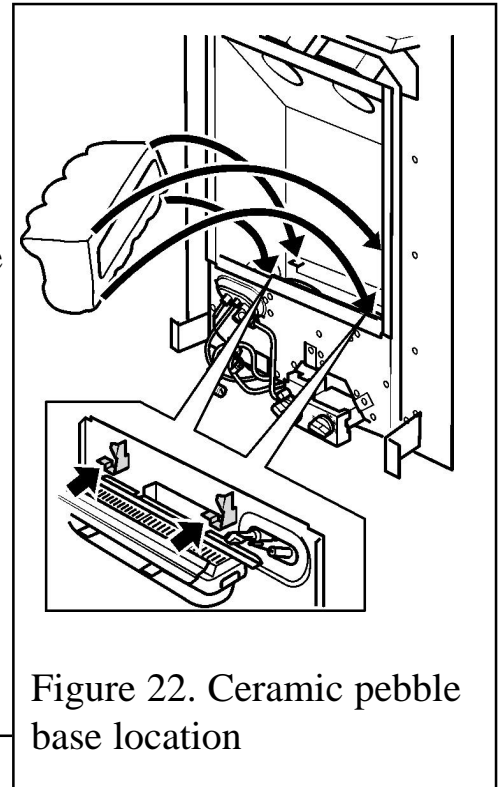

Figure 22. Ceramic pebble base location

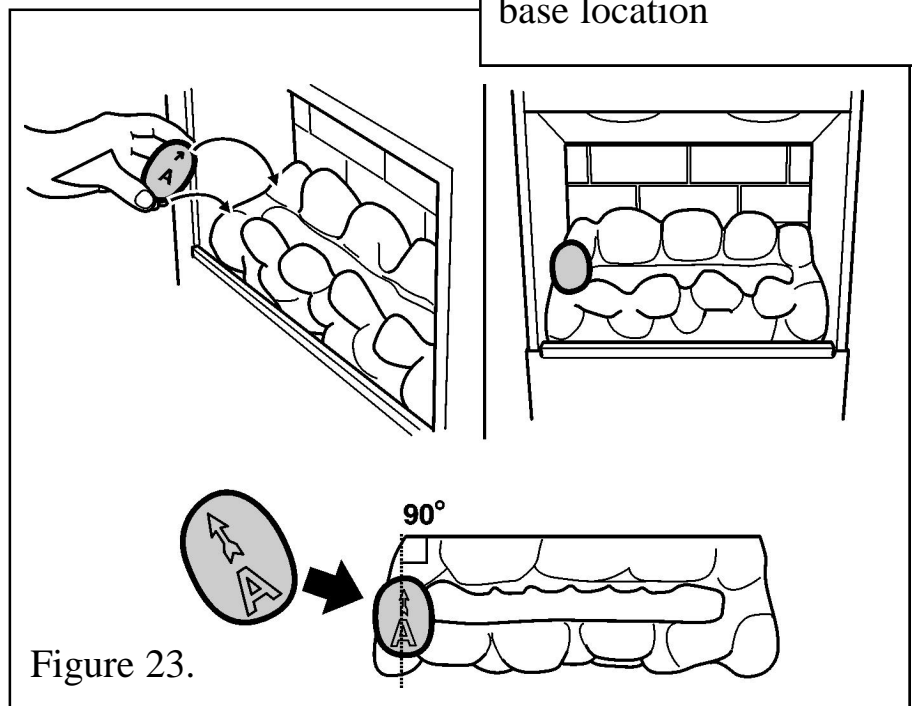
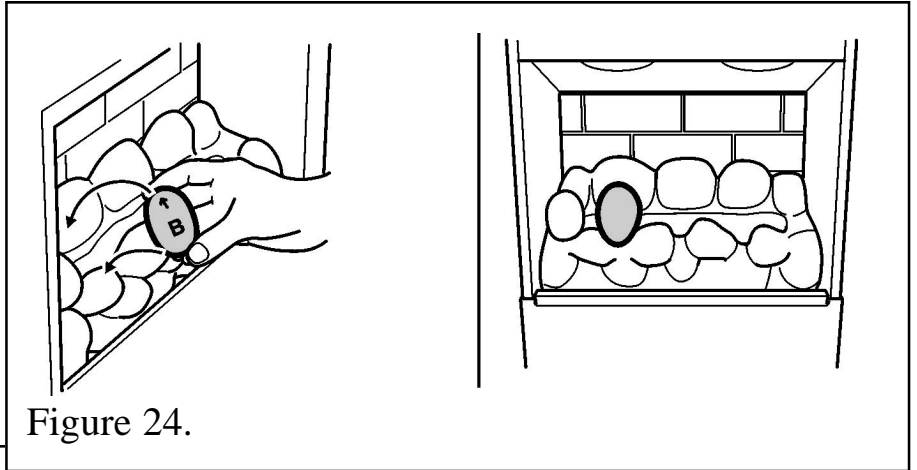

Figure 23.

INSTALLER GUIDE

3. Hold pebble 'B' upright with the arrow pointing to the top. Locate pebble 'B' as shown in figure 24.



4. Hold pebble 'C' upright with the arrow pointing to the top. Locate pebble 'C' as shown in figure 25.

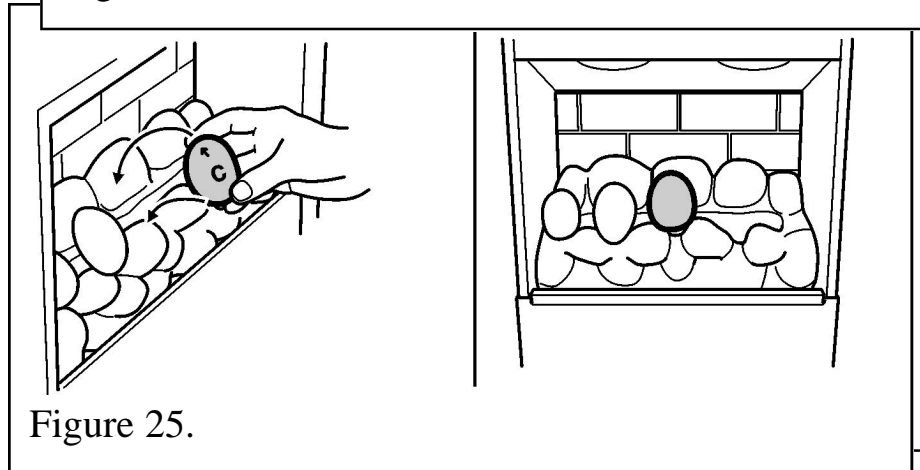

5. Hold pebble 'D' upright with the arrow pointing to the top. Locate pebble 'D' as shown in figure 26.

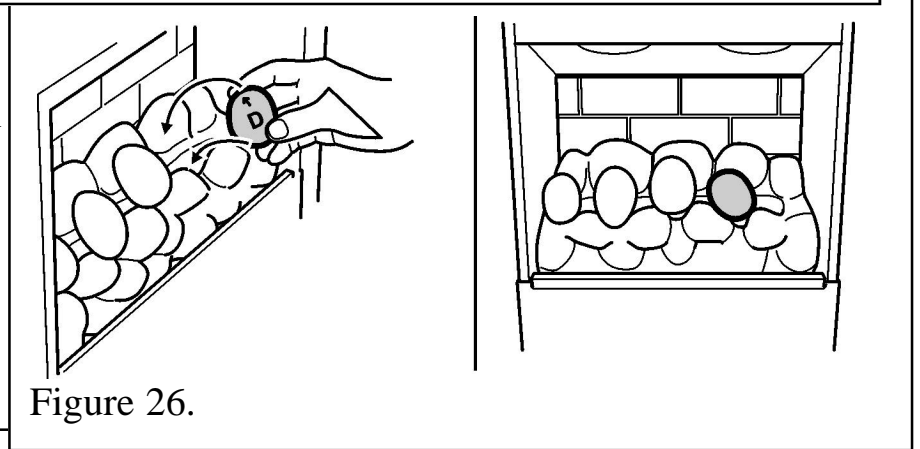

6. Hold pebble 'E' upright with the arrow pointing to the top. Locate pebble 'E' as shown in figure 27.

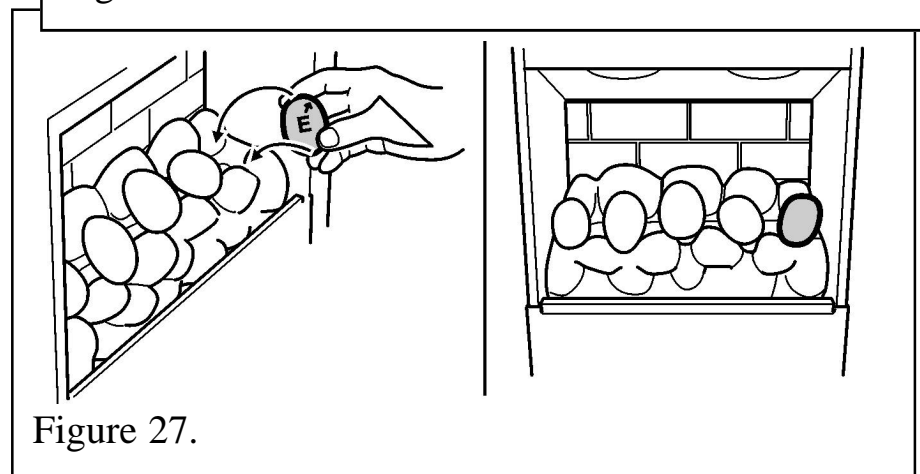

INSTALLER GUIDE

12. WINDOW FITTING

Fitting the window.

- Locate the channel at the top of the window over the top of the firebox opening.
- Refit the three spring loaded screws and washers. Tighten sufficiently to seal the firebox.
- **Pull the bottom of the window forward and release to check that the window opens slightly and returns in the event of a delayed ignition explosion.**

13. FULL OPERATING CHECKS

13.1 Check for leaks.

- Turn on the gas supply and check all joints up to the appliance gas tap for gas soundness using a soap solution or leak detection fluid.

13.2 Check control operation.



- Place the fascia in front of the fire and connect the battery and motor leads. The motor lead connectors are two different sizes. They will only fit to the correct motor terminals.

If the fire is turned off or the flames go out, wait at least 3 minutes before attempting to relight. A safety device in the control stops the fire being turned back on until it is safe.

(See figure 28).

- Depress the bottom half of the rocker switch located at the right side of the appliance case. This should cause the flame control knob (The left-hand control knob) to rotate clockwise until its bar is pointing vertically downward. A clicking sound will be heard while the flame control knob is rotating.

- Push in the right control knob and, while

keeping it depressed, turn anticlockwise through the ignition position marked  and up to the pilot position marked . The spark should light the pilot. The pilot flame can be seen by looking through the gap near the front left side of the ceramic fuel effect.

- If the pilot does not ignite, keep the knob depressed for a few seconds to purge air from the supply pipes. Then turn back to the off position marked  and repeat the ignition procedure.

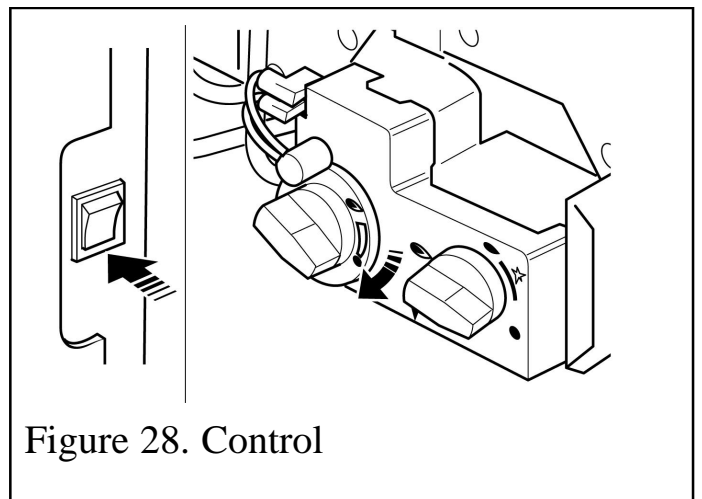





Figure 28. Control

INSTALLER GUIDE

- When the pilot has lit, keep the right hand control knob depressed for a few seconds to allow the pilot flame to stabilise then release it. If the pilot does not remain alight ensure that the air has been purged.
- Partially depress the right control knob and turn to the main burner position marked .
- The left-hand knob is for burner flame adjustment. In its fully clockwise position it turns the main burner off. Depressing top half of the rocker switch should cause the flame control knob to rotate anticlockwise direction. This should light the main burner and gradually increase the flame height. The maximum flame height should be achieved when the bar of the flame control knob is pointing vertically upwards.
- After checking up to maximum flame height, depress the bottom half of the rocker switch until the main burner is extinguished.
- The flame control rocker switch does not have to be operated every time the fire is lit or turned off. The main burner setting will remain at its previously chosen position enabling the customer to use the right hand control only to ignite the burner at that setting and to turn the fire off.
- After checking turn the right hand knob to off. Depress the control knob partially at the pilot position (), turn clockwise to off () and release the knob. If any resistance is felt when turning, release the downward pressure on the knob before continuing to turn.

13.3 Checking inlet pressure.

The burner aeration is non-adjustable. The appliance is preset to give the correct heat input on Natural Gas at 20 mbar (8in w.g) inlet pressure and no further adjustment is necessary. The burner pressure should be checked at the pressure test point located on the inlet 'T' connector (See figure 29). The pressure check should be carried out using a calibrated pressure gauge after removing the test point screw. The fire should be alight and the left hand control knob at its fully anticlockwise setting (Maximum flame height). The pressure setting should be within the limits shown in section 3 of this manual (Appliance data). After checking the pressure, turn off the fire, remove the pressure gauge and replace the pressure test sealing screw. Relight the fire and test all gas joints for soundness using a suitable leak detection fluid.

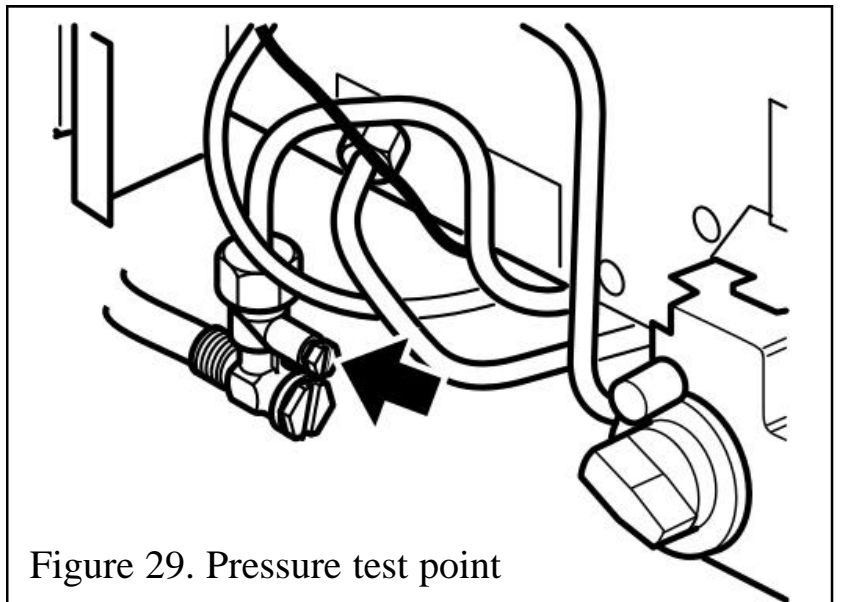

Figure 29. Pressure test point

INSTALLER GUIDE

14. FASCIA FITTING

14.1 Fitting the Decadent fascia

- Remove any protective film from the fascia.
- Locate the two lugs at the top of the fascia in the slots in the convection box hood. Swing the bottom of the fascia sides back against the convection box and lower the fascia so that the lugs are fully seated in the slots in the convection box hood (See figure 30).
- Refit the two screws to secure the bottom of the fascia sides to the convection box side brackets.
- Check that the two screws in the back of the fire front casting are in the inner threaded holes. If they are in the outer holes, relocate them (See figure 31)
- Fit the fire front casting between the fascia sides. Where fitted to the casting, locate the two screw heads at the rear top corners of the casting through the keyhole slots at the inner sides of the fascia. If the screw heads do not project enough or project too far, the screws can be adjusted.
- Lower the casting so that it rests on the hearth (See figure 32).
- Fit the "ash pan" cover below the front casting locating it as shown in figure 33.

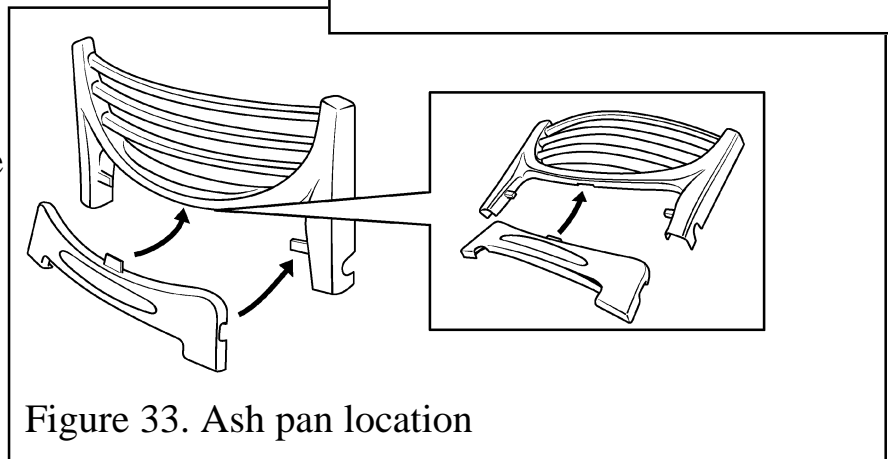
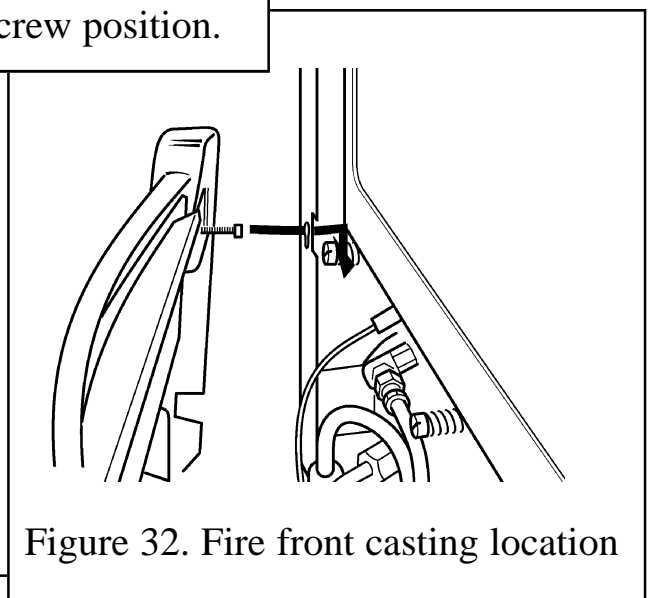
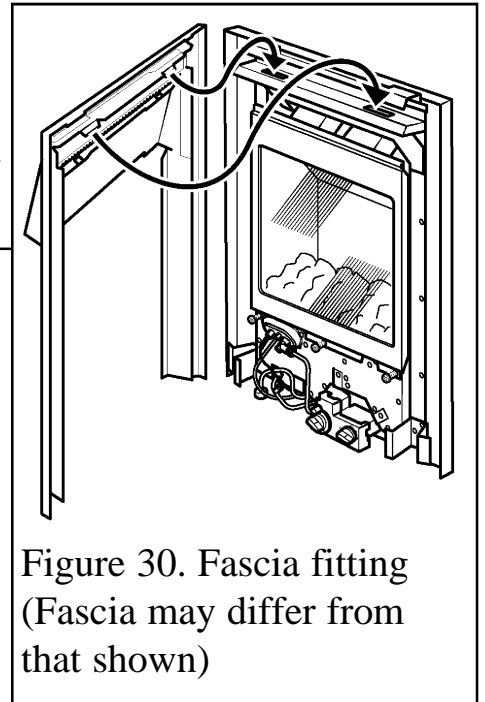
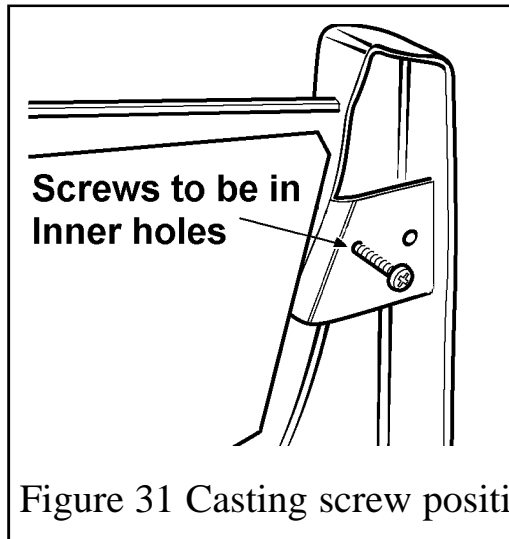

INSTALLER GUIDE

14.2 Fitting the Chic fascia

- Remove any protective film from the fascia.
- Locate the two lugs at the top of the fascia in the slots in the convection box hood. Swing the bottom of the fascia sides back against the convection box and lower the fascia so that the lugs are fully seated in the slots in the convection box hood (See figure 34).
- Secure the bottom of the fascia sides to the convection box side brackets using the two screws supplied (See figure 34).
- Supplied in the fascia pack are two tubular trim sets. Hang these to the tabs on the fascia (See figure 35).
- The lower section of the fascia is secured with magnets. Locate it as in figure 36. The bottom of the lower section should sit on the tags as shown.

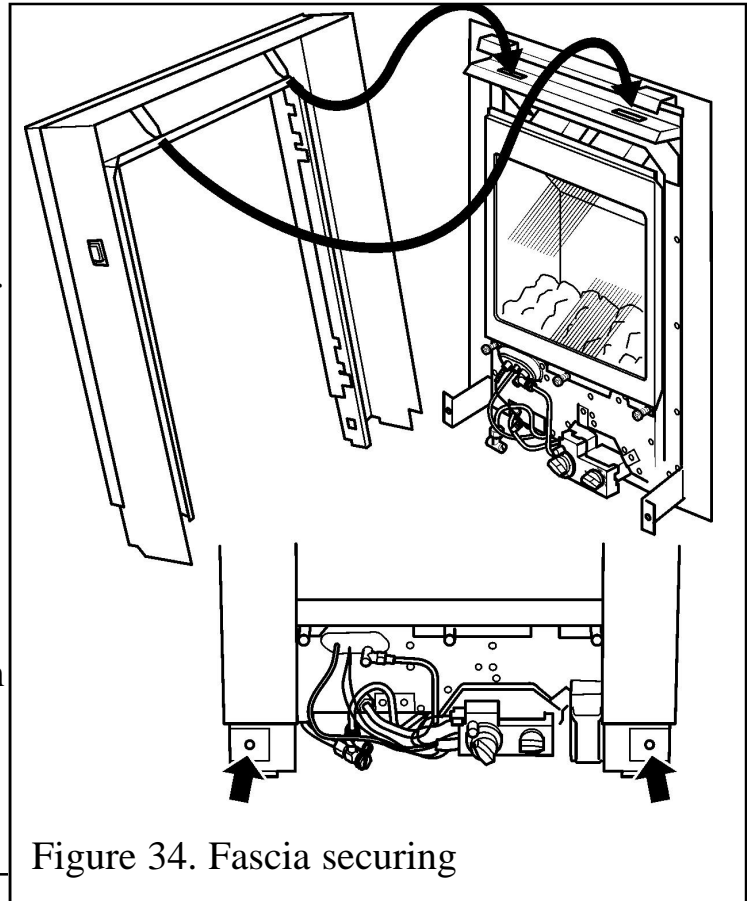

Figure 34. Fascia securing

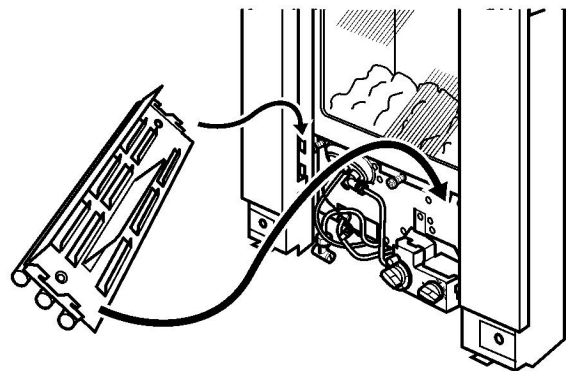
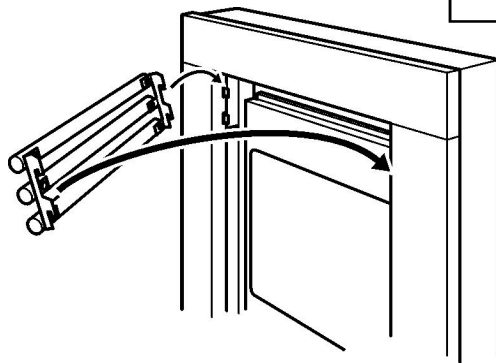

Figure 35. Fitting the 'Chic' hanging trims

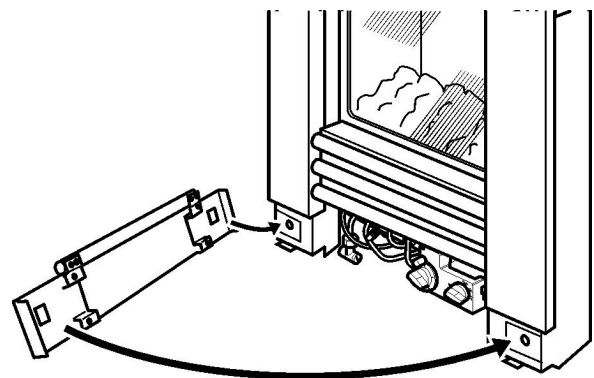

Figure 36. Fitting the lower section to the 'Chic' fascia.

INSTALLER GUIDE

15. FINAL REVIEW

- Recheck the pilot ignition and operation of the fire through the range of settings.
- Visually inspect the appliance. Clean off any marks incurred during installation.
- Advise the customer to read their owner guide before operating the fire and to always follow the advice in the section headed “Cleaning Your Fire”.
- **Stress that no loose ceramic fuel effect pieces must be added to the ceramic fuel effect supplied with the appliance and that any replacement ceramic fuel effect must only be the authorised spare.**
- Advise the customer how to operate the appliance. Take the customer through the full operating sequence step by step. Point out that lighting instruction details are contained on the plate attached at the bottom of the appliance. Leave the plate visible in front of the bottom front cover as a reminder to the customer.
- Advise the customer that the pilot flame can be viewed to ensure that it is alight. Show the user where to view the pilot and point out the illustration in the owner guide showing how to view the pilot.
- Advise the customer that the pilot can be left alight but mention that if the premises are to be left unoccupied for a lengthy period, it is advisable to turn the pilot off.
- **Emphasise that if the glass panel is broken or damaged, the fire should be turned off and not used until the window unit is refitted with an authorised replacement.**
- Recommend that the appliance should be serviced by a competent person (In the UK preferably a CORGI registered person) at least annually. *If the appliance is in premises in the United Kingdom occupied by a tenant, point out that by law a landlord must have any gas appliance, flue and pipework which is situated in a tenant’s premises checked for safety at least every 12 months.*
- Hand the literature pack with this guide to the customer.

INSTALLER GUIDE

16. SERVICING & PARTS REPLACEMENT

Always turn off the gas and allow the appliance to cool completely before commencing any servicing. (The inlet 'T' connector on this appliance incorporates an isolating valve)

Always test for gas soundness after refitting the appliance.

This product uses a fuel effect, a burner compartment rear wall and gaskets containing Refractory Ceramic Fibres (RCF), which are man-made vitreous silicate fibres. Excessive exposure to these materials may cause irritation to eyes, skin and respiratory tract. Consequently, it is important to take care when handling these articles to ensure that the release of dust is kept to a minimum. To ensure that the release of fibres from these RCF articles is kept to a minimum, during installation and servicing we recommend that you use a HEPA filtered vacuum to remove any dust and soot accumulated in and around the fire before and after working on the fire. When replacing these articles we recommend that the replaced items are not broken up, but are sealed within a heavy duty polythene bag, clearly labelled as RCF waste. This is not classified as "hazardous waste" and may be disposed of at a tipping site licensed for the disposal of industrial waste. Protective clothing is not required when handling these articles, but we recommend you follow the normal hygiene rules of not smoking, eating or drinking in the work area and always wash your hands before eating or drinking.

16.1 To remove the fascia.

Decadent

- Remove the bottom front casting.
- Lift the fire front casting clear by lifting the fire front casting up and forward. This will release the locating screw heads at the back of the casting from the keyholes in the fascia sides.
- Remove the wiring loom connectors from the right hand side of the gas valve.
- Remove the two screws securing the bottom of the fascia to the sides of the convection box.
- Raise the fascia to allow the retaining lugs at the top to clear the slots in the convection box hood and then lift clear (See figure 37). Be careful not to trap the wiring loom when lifting clear.

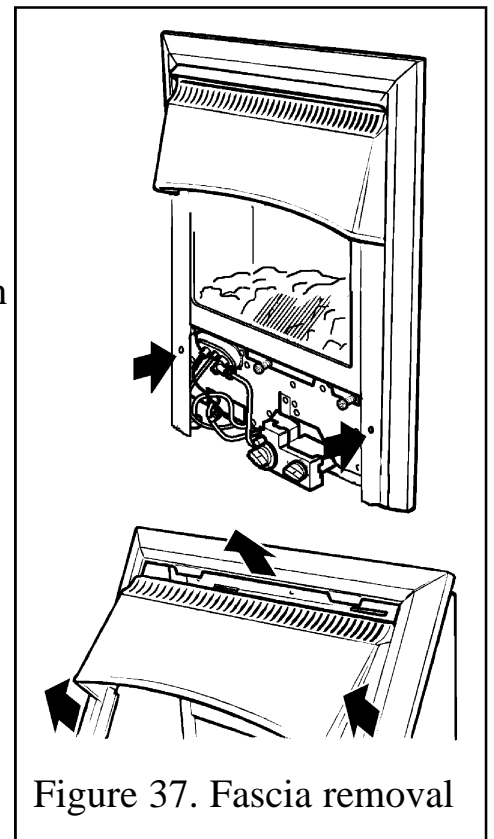

Figure 37. Fascia removal

INSTALLER GUIDE

Chic

- The lower section of the fascia is secured with magnets. Remove this by pulling clear of the fascia (See figure 38).
- Remove the two tubular trim sets from the top and bottom of the fascia. To do this simply lift upward and forward (See figure 39).
- Unscrew and remove the two screws that secure the bottom of the fascia sides to the convection box (See figure 39).
- Remove the wiring loom connectors from the left hand side of the gas valve.
- Raise the fascia to allow the retaining lugs at the top to clear the slots in the convection box hood and then lift clear (See figure 40). Be careful not trap the wiring loom when lifting clear.

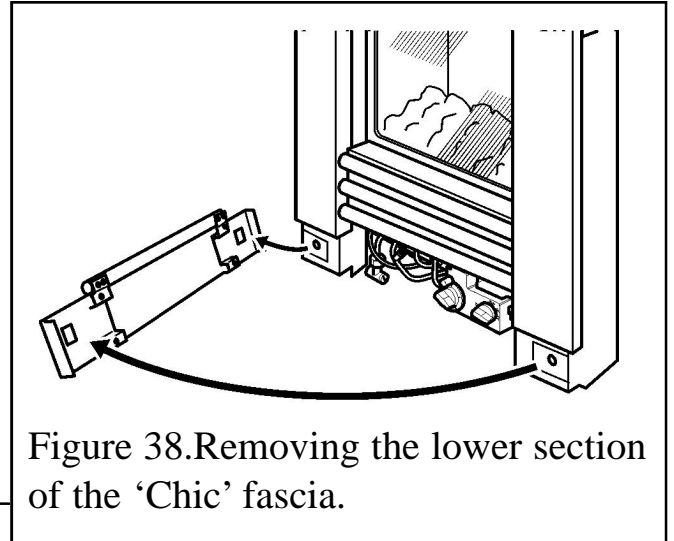

Figure 38. Removing the lower section of the 'Chic' fascia.

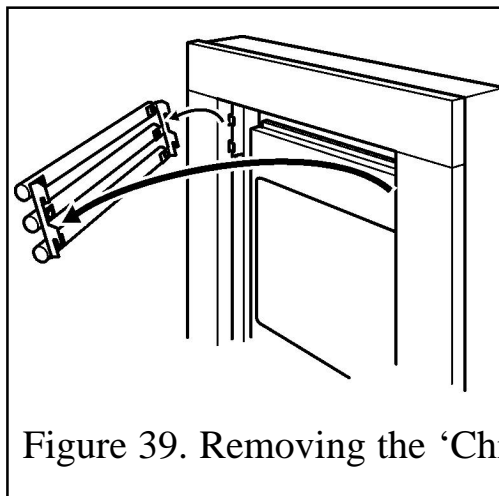

Figure 39. Removing the 'Chic' hanging trims

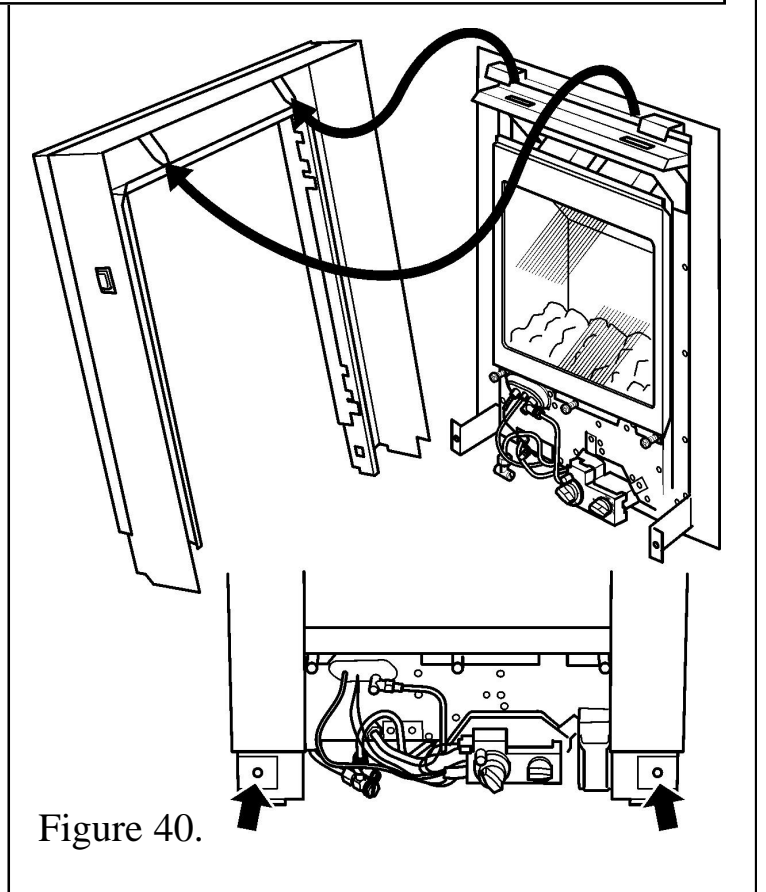
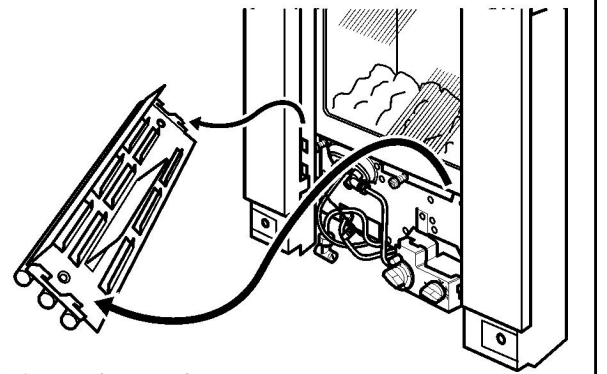

Figure 40.

INSTALLER GUIDE

16.2 To remove window unit.

- Remove the fascia (See section 16.1).
- Unscrew and remove the three spring-loaded window-fixing screws and washers from the base of the window frame (See figure 41).
- Gently swing the base of the window frame forward while lifting the frame upward. The window should lift clear of the fire. Put the window in a safe place away from your immediate work area.

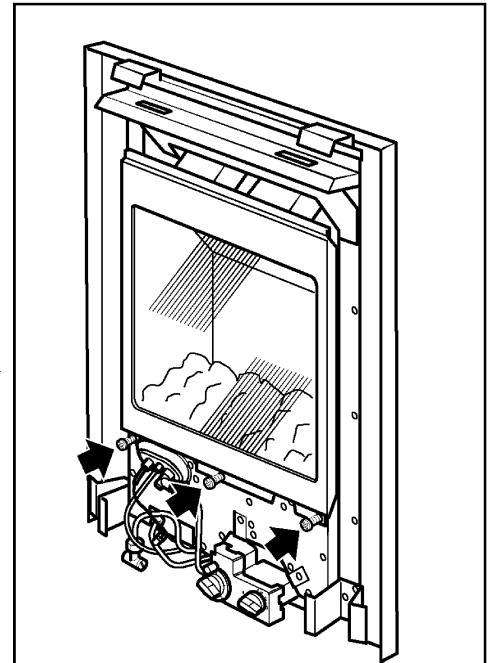

Figure 41. Window fixing

16.3 To remove the ceramic fuel effect and rear wall.

- Remove the fascia (See section 16.1).
- Remove the window unit (See section 16.2)
- Lift out the ceramic fuel effect.
- Remove the rear wall by carefully sliding it upwards to clear the retaining channel and then swinging the top slightly forward.

16.4 To remove the complete burner module.

- Remove the fascia (See section 16.1).
- Remove the window unit (See section 16.2).
- Lift out the ceramic fuel effect and rear wall (See section 16.3).
- Isolate the gas supply using the inlet 'T' connector on the appliance.
- Unscrew the nut from the top of the inlet 'T' connector.
- Detach the battery box from the fire unit by removing two screws (See figure 42).
- Detach the burner front cover by unscrewing the 10 screws at the front of the burner module shown in figure 43.
- Slowly ease the burner module forward and clear ensuring that the thermocouple does not catch on the bottom of the firebox.
- Replace in reverse order.
- When replacing, make sure that the wiring loom runs above and to the right of the battery box and behind the control valve (See figure 44). The motor lead connectors are two different sizes. They will only fit to

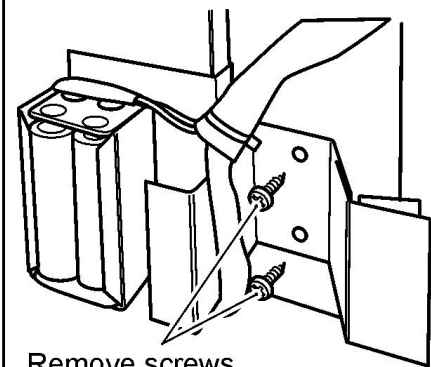

Remove screws

Figure 42. Bracket may differ from that shown

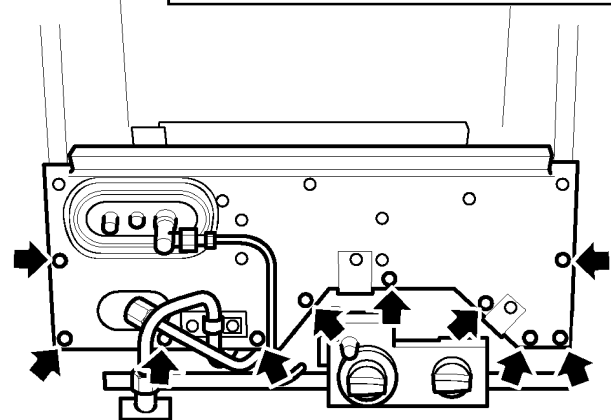

Figure 43. Burner module fixing screws.

INSTALLER GUIDE

the correct motor terminals.

16.5 To remove the burner from the burner module.

- Remove the complete burner module as in section 16.4
- Support the injector elbow and unscrew the pipe nut from its base.
- The burner bracket is secured to the front cover by four screws. Remove these screws.
- The burner and its bracket can now be lifted clear of the module.
- If replacing the burner unscrew the two nuts securing the burner bracket to the burner. Remove the burner.
- Replace in the reverse order.
- When replacing, make sure that the wiring loom runs above and to the right of the battery box and behind the control valve (See figure 44). The motor lead connectors are two different sizes. They will only fit to the correct motor terminals.

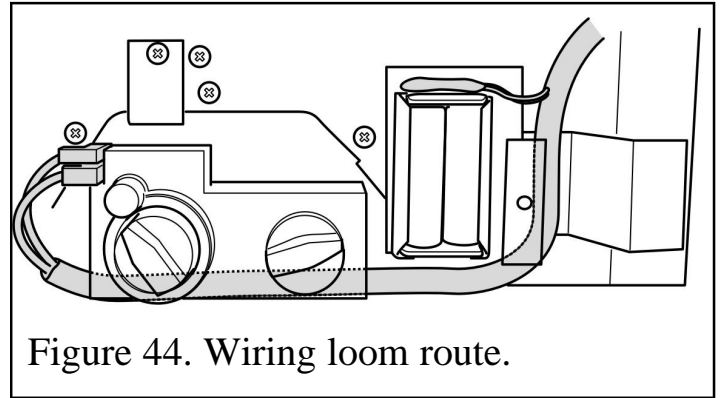

Figure 44. Wiring loom route.

16.6 To remove the injector.

- Remove the complete burner module as in section 16.4
- Support the injector elbow and unscrew the pipe nut from its base.
- The burner bracket is secured to the front cover by four screws. Remove these screws.
- The burner and its bracket can now be lifted clear of the module.
- Unscrew the injector from the burner.
- Replace in the reverse order.
- When replacing, make sure that the wiring loom runs above and to the right of the battery box and behind the control valve (See figure 44). The motor lead connectors are two different sizes. They will only fit to the correct motor terminals.

16.7 To remove the pilot unit.

(See figure 45).

Note: The Pilot unit must be replaced as a whole assembly. Its individual components are not separately replaceable.

- Remove the complete burner module as in section 16.4
- Remove the electrode lead at the pilot. Do this by holding the lead as close to the electrode

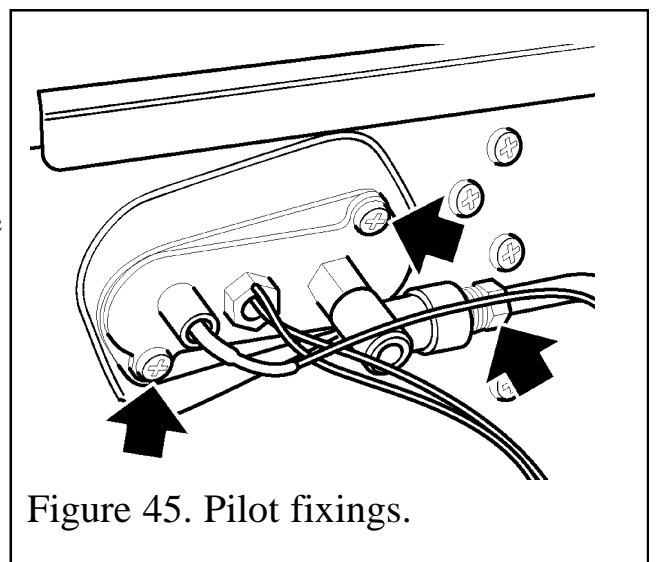

Figure 45. Pilot fixings.

INSTALLER GUIDE

as possible. This will limit the possibility of damaging the lead connection.

- Unscrew the nut connecting the pilot to the pilot pipe.
- Unscrew the thermocouple at the rear of the gas valve.
- Unscrew the two screws securing the pilot to the module front.
- If the pilot gasket is damaged in any way it must be replaced.
- Replace in reverse order.
- When replacing, make sure that the wiring loom runs above and to the right of the battery box and behind the control valve (See figure 44). The motor lead connectors are two different sizes. They will only fit to the correct motor terminals.

16.8 To remove the gas valve.

- Remove the complete burner module as in section 16.4
- Remove the electrode lead at the pilot. Do this by holding the lead as close to the electrode as possible. This will limit the possibility of damaging the lead connection.
- Unscrew the thermocouple at the rear of the gas valve.
- Undo the inlet, outlet and pilot nuts on the gas valve.
- Remove the two mounting screws on the underside of the gas valve (See figure 46).
- Remove the valve by sliding it forward.
- Replace in reverse order.
- When replacing, make sure that the

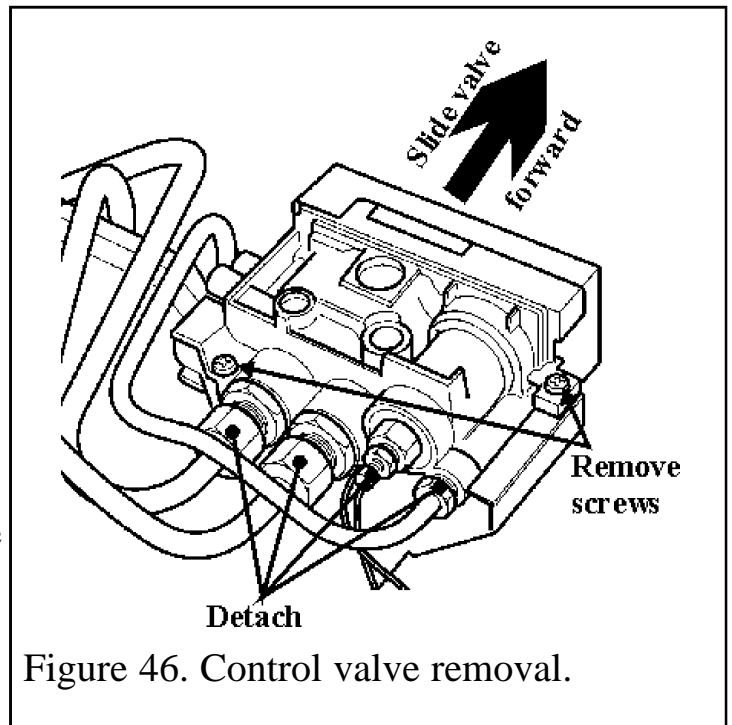

Figure 46. Control valve removal.

wiring loom runs above and to the right of the battery box and behind the control valve (See figure 44). The motor lead connectors are two different sizes. They will only fit to the correct motor terminals.

16.9 To remove the switch and wiring loom.

(See figure 47).

- Remove the fascia (See section 13.1).
- Disconnect the two motor leads from the top left of the gas valve.
- Cut the cable tie securing the loom to the battery box bracket. Pull the loom out from behind the control valve.
- Detach the two leads from the plastic battery holder.
- Press firmly inward the two retaining claws on the inside of the rocker switch. Remove the loom through the switch aperture in the case side.
- Replace in the reverse order.

INSTALLER GUIDE

- When replacing the switch make sure that the white printing on the switch side faces the back of the fire. If the printing faces the front, pressing the upper half of the switch will lower the flame height.
- When replacing, make sure that the wiring loom runs above and down to the right of the battery box and behind the control valve (See figure 47).
- Secure the loom to the battery box bracket with the cable tie supplied with the new loom - check that there is sufficient free length of loom wire to allow the battery holder to be removed from & replaced in the battery box before securing the cable tie.
- The motor lead connectors are two different sizes. They will only fit to the correct motor terminals.

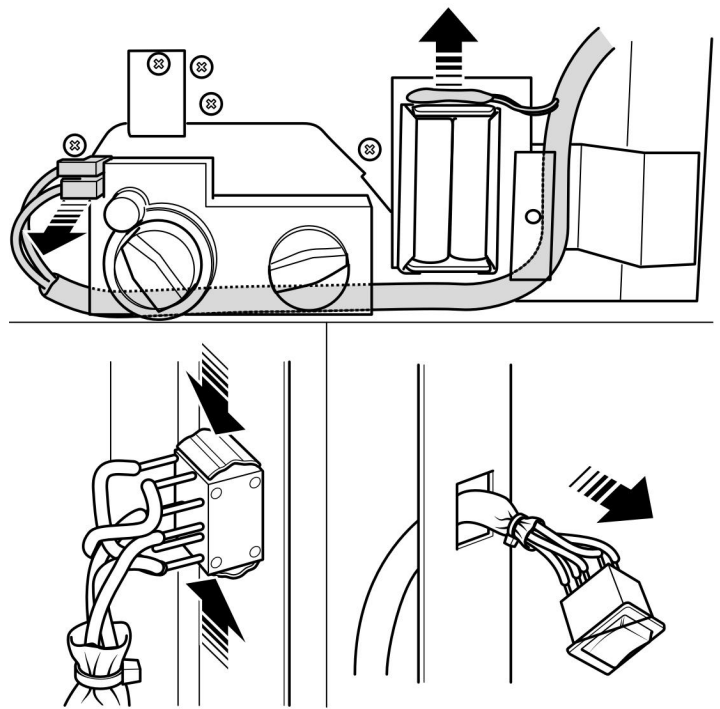

Figure 47. Switch and wiring loom removal.

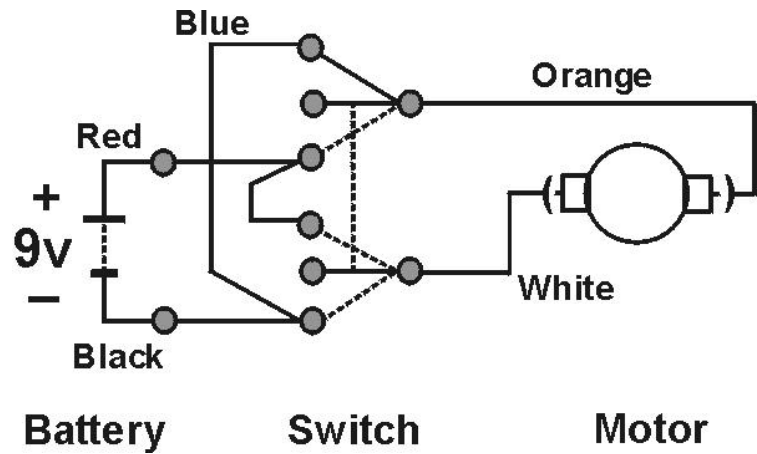

Figure 48. Wiring diagram.