

# BAXI FIRES DIVISION

## OWNER GUIDE

### Model 541

ROOM SEALED RADIANT/CONVECTOR  
GAS FIRE

Fitted with

**Ultimate** fascia

(GC No. 32-032-64)



**THIS APPLIANCE IS FOR USE WITH NATURAL GAS (G20).  
THIS APPLIANCE IS SUITABLE ONLY FOR INSTALLATION IN THE UNITED  
KINGDOM (GB) AND THE REPUBLIC OF IRELAND (IE).**

We trust that this guide gives sufficient details to enable this appliance to be operated and maintained satisfactorily. However, if further information is required, our

**Baxi Fires Division Technical Helpline** will be pleased to help.

Telephone **08706 061 065** (National call rates apply in the United Kingdom). In the Republic of Ireland telephone **0044 8706 061 065**.

This guide is intended to help you care for your Baxi Fires Division gas fire. Please read thoroughly before using and keep for future reference.

**This guide to be left with the owner**

**BAXI ● VALOR ● WONDERFIRE**

# OWNER GUIDE

## **Safety First.**

Baxi Fires Division fires are CE Approved and designed to meet the appropriate British Standards and Safety Marks.



## **Quality and Excellence.**

All Baxi Fires Division fires are manufactured to the highest standards of quality and excellence and are manufactured under a BS EN ISO 9001 quality system accepted by the British Standards Institute.



## **The Highest Standards**

Baxi Fires Division is a member of the Society of British Gas Industries which works to ensure high standards of safety, quality and performance.



## **Careful Installation**

Baxi Fires Division is a CORGI registered company. All our gas fires must be installed by a competent CORGI Registered Installer in accordance with our Installer Guide and should not be fitted directly on to a carpet or floor of combustible material.

# B A X I F I R E S D I V I S I O N

Baxi Fires Division, Erdington, Birmingham B24 9QP  
[www.firesandstoves.co.uk](http://www.firesandstoves.co.uk)

Because our policy is one of constant development and improvement, details may vary slightly from those given in this publication

# OWNER GUIDE

## CONTENTS

<u>Section</u>	<u>Heading</u>	<u>Page</u>
<b>SAFETY</b>		<b>4</b>
<b>APPLIANCE DIMENSIONS</b>		<b>6</b>
<b>GAS CONSUMPTION</b>		<b>6</b>
<b>OPERATING YOUR FIRE</b>		<b>6</b>
	To light the pilot.	7
	To light the main burner.	7
	To Turn off the main burner only.	7
	To turn off the main burner and pilot.	8
<b>CLEANING YOUR FIRE</b>		<b>8</b>
	Metal parts.	8
	To clean the inside of the window.	8
	Window removal and cleaning.	8
	To clean the ceramic fuel effect or ceramic rear wall.	9
<b>SERVICING AND MAINTENANCE</b>		<b>10</b>
	Regular maintenance.	10
	Servicing.	10
<b>USEFUL TELEPHONE NUMBERS</b>		<b>11</b>

---

This gas fire is designed to meet the most stringent quality, performance and safety requirements to provide you with many years' trouble-free service.

This guide aims to improve your understanding and appreciation of your gas fire by providing simple and informative instructions to ensure that you benefit from the excellent performance and features it has to offer.

# OWNER GUIDE

## SAFETY

### IF YOU SMELL GAS

**DON'T SMOKE**

**EXTINGUISH ALL NAKED FLAMES**

**DON'T TURN ELECTRICAL SWITCHES ON OR OFF**

**TURN OFF THE GAS SUPPLY AT THE METER**

**OPEN DOORS AND WINDOWS TO GET RID OF THE GAS**

**IMMEDIATELY CALL THE GAS EMERGENCY SERVICE – SEE YOUR LOCAL TELEPHONE DIRECTORY**

**Do** have the fire installed by a competent person. In the United Kingdom, installation must be in accordance with the latest edition of the Gas Safety (installation & use) Regulations. In the Republic of Ireland, installation must be in accordance with all national and local regulations in force.

**Do** have the fire installed in accordance with the installer guide.

**Do** provide a minimum clearance of 780mm from the base of the fire to any shelf made of wood or other combustible material where the shelf is not more than 150mm deep. For a shelf deeper than 150mm, add 12.5mm to the clearance for every 25mm of additional shelf depth (See graph 1)

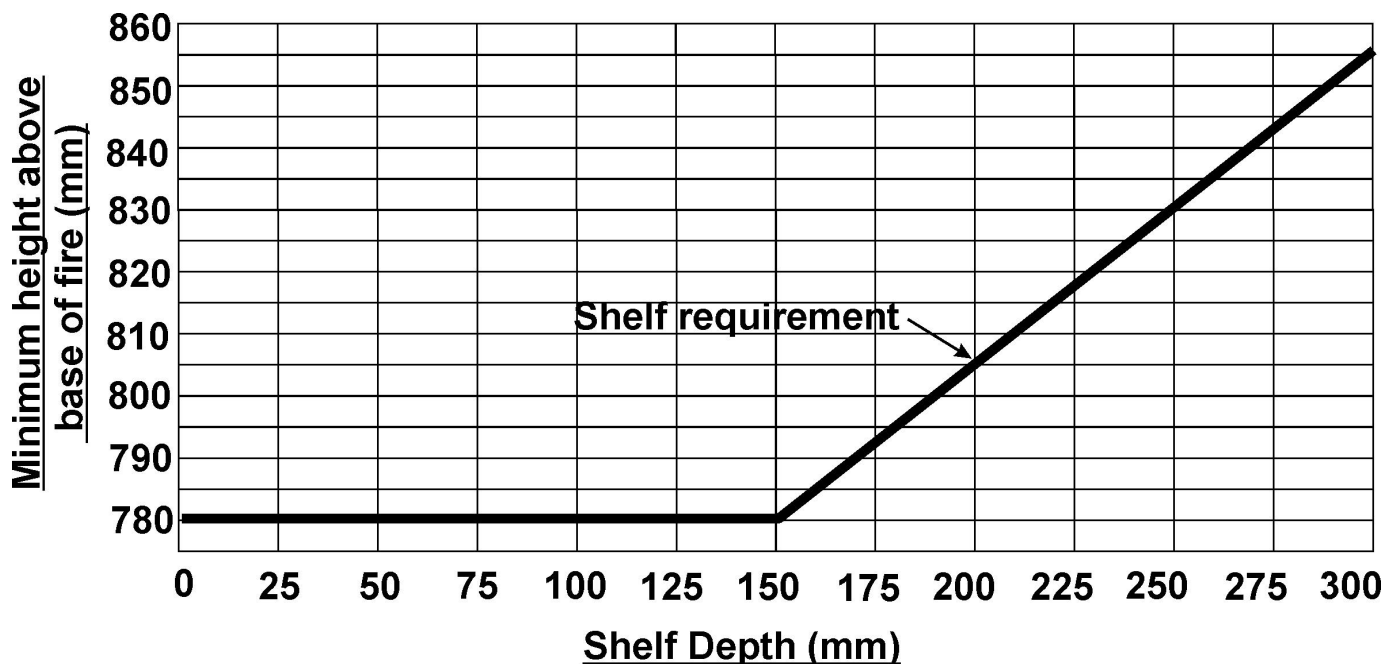

Graph 1. Combustible shelf clearances.

**Do** provide a minimum clearance of 51mm each side of the fire for servicing access.

**Do** provide a suitable guard which complies with BS 8423 for the protection of young

# OWNER GUIDE

children, the elderly and the infirm. Such a guard is also recommended for the protection of pet animals. *Although this fire conforms to all the applicable standards, it is a heating appliance and certain parts of its surface will become hot.*

**Do** wait three minutes before attempting to relight if the fire is switched off or the flames are extinguished for any reason. *Your fire is fitted with a safety device which will automatically shut off the gas supply to the fire if, for any reason, the flames go out.*

**Do** get advice about the suitability of any wall covering near your fire. Soft wall coverings (e.g. embossed vinyl, etc.) which have a raised pattern, are easily affected by heat. They may, therefore, scorch or become discoloured when close to a heating appliance. Please bear this in mind whenever you are considering redecorating (See section 4.15 of the installer guide).

**Do** keep the flue terminal on the outside wall free from all obstructions and blockages.

**Don't** hang clothing, towels or any other fabrics over the fire.

**Don't** use the fire without the glass window panel in position or with damaged glass.

**Don't** add any loose ceramic fuel effect pieces on to the ceramic fuel effect supplied with the fire. This could cause a safety hazard.

**Don't** use the fire without the ceramic fuel effect and rear wall correctly in position or if they are damaged.

**Don't** place any carpet, rug or other soft surface material under or within 300mm forward of the appliance over its full width side-to-side. (Although this fire does not have to be on a non-combustible hearth, such soft materials could interfere with the air flow into and through the bottom of the heater)

**Don't** attempt to clean or service the fire until it has been switched off and allowed to cool completely.

# OWNER GUIDE

## APPLIANCE DIMENSIONS

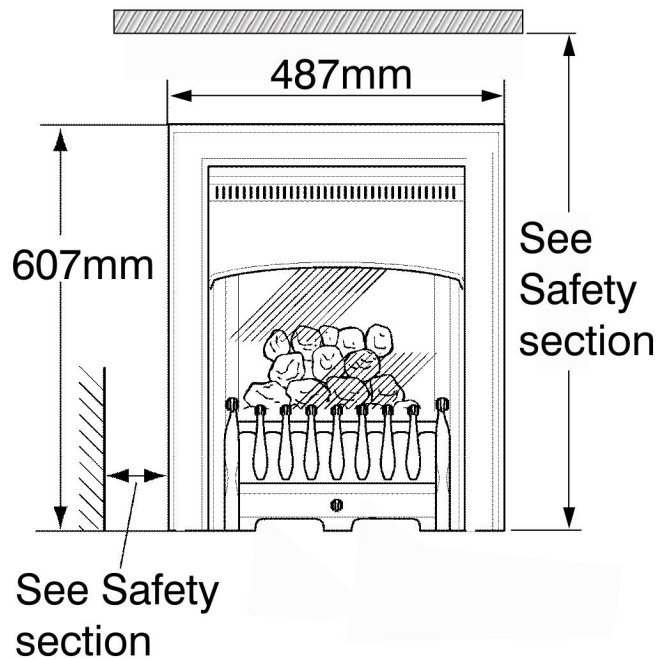

Figure 1. Appliance dimensions (Dimensions are subject to manufacturing deviation)

## GAS CONSUMPTION

### Model 541

Has a maximum natural gas input of 3.65kW (Gross)

Has a maximum natural gas output of 2.8kW

Has a minimum natural gas input of 1.5kW (Gross)

Has a minimum natural gas output of 1.13kW

## OPERATING YOUR FIRE

The pilot may be left alight. It is advisable, however, that the pilot is turned off if the premises are to be left unoccupied for a lengthy period.

For your safety the fire is fitted with a flame supervision device which will shut off the gas supply if for any reason the pilot goes out. This device incorporates a fixed probe which senses the heat from the pilot flame. If the probe is cool the device will prevent any gas flow unless the pilot lighting knob is held in. This device also stops the fire being turned back on until it is safe after it has been turned off.

If, for any reason, the fire goes out or if the fire is turned off, always **wait at least three**

# OWNER GUIDE

minutes before attempting to relight

If the device starts to shut off the gas frequently, get expert advice.

The controls are shown in figure 2.

## To light the pilot.

- Push in the right control knob (the pilot lighting knob) and, while keeping it depressed, turn anticlockwise through the ignition position marked  and up to

- the pilot position marked . The spark should light the pilot. The pilot flame can be seen by looking through the gap near the left side of the coal front (See figure 3).

- When the pilot has lit, keep the right hand control knob depressed for a few seconds to prevent the flame supervision device from shutting off the gas supply while its probe warms up, as explained above, then release it. If the pilot does not remain alight turn the knob back to the off position marked . Wait a few seconds and repeat the lighting sequence.

## To light the main burner.

- Partially depress the right control knob and turn to the main burner position marked . The main burner should now light at its low position.

- The left-hand knob is for burner flame adjustment. Turning it anticlockwise should gradually increase the flame height and heat output. Turning clockwise reduces the flame height and heat output.

- The burner flame control does not have to be re-set every time the fire is lit. Once set, it can be left at that position allowing you to use the right hand control only to ignite the burner at the set flame height.

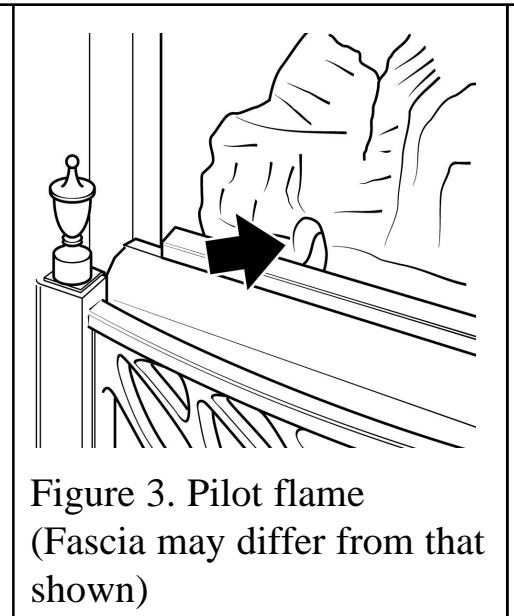
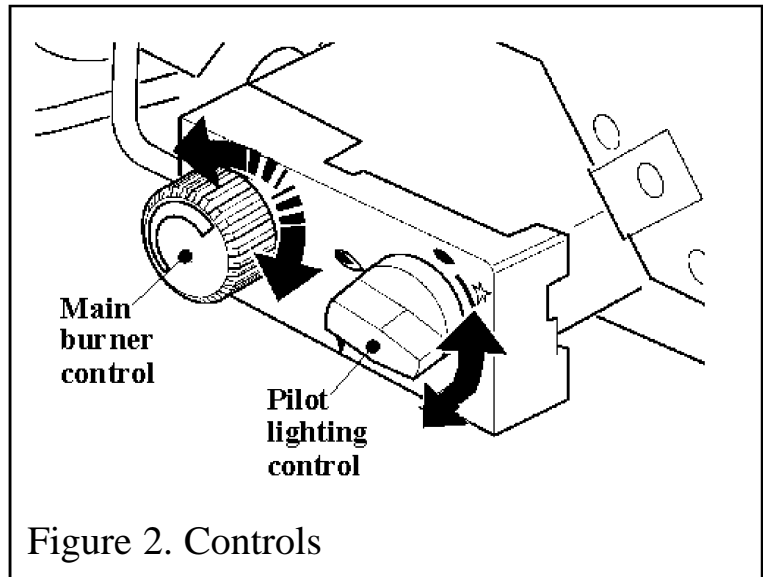

## To Turn off the main burner only.

- Turn the right hand control knob to the pilot position marked .



# OWNER GUIDE

## To turn off the main burner and pilot.

- Turn the right hand control knob to the pilot position marked . Push the knob in at this position and turn to the off position marked .

## CLEANING YOUR FIRE

Turn the fire off and allow it to cool completely before attempting any cleaning. Note that the fire will retain heat for some time after it has been turned off.

### Metal parts.

Clean the metal parts with a slightly damp cloth and then dry. **Do not use abrasive cleaners, they could scratch the surface.**

### To clean the inside of the window.

Before the window can be detached, the fascia will have to be removed as follows:

(See figure 4).

- Remove the bottom front casting.
- Lift the fire front casting clear by lifting the fire front casting up and forward to release the locating screw heads at the back of the casting from the keyholes in the fascia.
- Remove the two screws securing the bottom of the fascia to the sides of the convection box.
- Raise the fascia to allow the retaining lugs at the top to clear the slots in the convection box hood and then lift clear.

### Window removal and cleaning.

- Unscrew and remove the three spring loaded window fixing screws and washers from the base of the window frame (See figure 5). Keep the screws and washers in a safe place.
- Gently swing the base of the window frame forward while lifting the frame upwards. The window should lift clear of the fire. Put the window in a safe place away from your immediate work area.
- Any stains on the glass can be removed with a non-abrasive cleaner such as a ceramic hob cleaner. Never

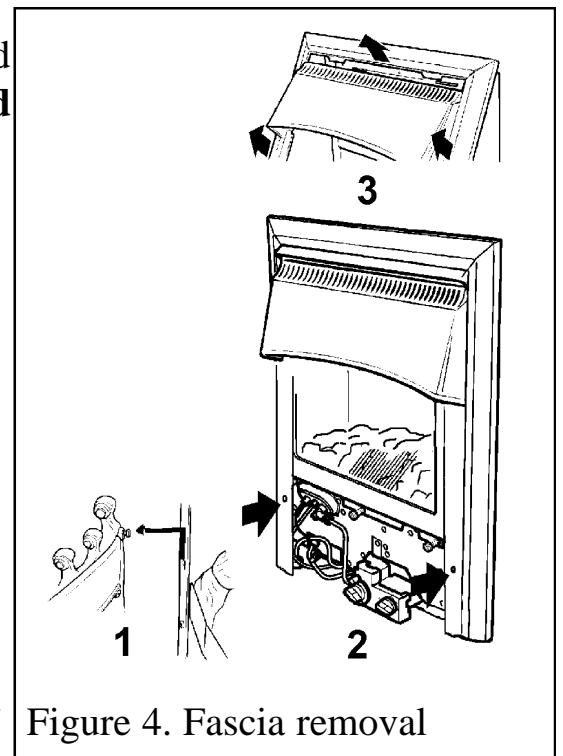

Figure 4. Fascia removal

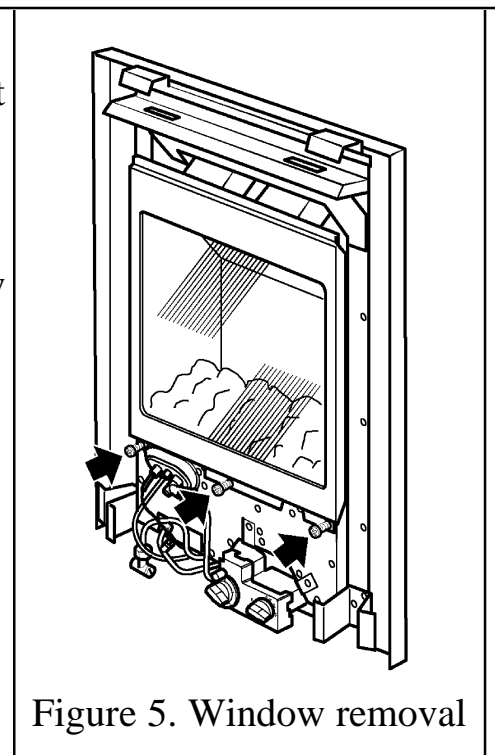

Figure 5. Window removal



# OWNER GUIDE

use abrasive cleaners. Clean the window carefully in accordance with the instructions supplied with the cleaner.

- Replace the window making sure that the seal around the frame is not damaged or misplaced. Locate the channel at the top of the window over the top of the firebox opening.
- Refit the three spring-loaded screws and washers. Tighten sufficiently to seal to the firebox.
- Replace the fascia and castings.

## **To clean the ceramic fuel effect or ceramic rear wall.**

- **This product uses a ceramic fuel effect, a burner compartment rear wall and gaskets containing Refractory Ceramic Fibres (RCF), which are man-made vitreous silicate fibres. Excessive exposure to this material may cause irritation to eyes, skin and respiratory tract. Consequently, it is important to take care when handling these articles to ensure that the release of dust is kept to a minimum.**
- Light coatings of soot will usually be burnt off during the normal operation of the fire. Should any soot accumulation become excessive, the ceramic fuel effect and rear wall should be removed from the fire for cleaning.
- Cleaning should be carried out in a well ventilated area or in the open air by gently brushing with the pieces held away from your face so that you avoid inhaling the dust.
- We do not recommend the use of a normal domestic vacuum cleaner which may blow dust back into the air.

If, for any reason the ceramic fuel effect or rear wall require cleaning proceed as follows:-

- Remove the fascia and window as described above.
- Carefully lift the ceramic fuel effect out of the firebox and place it on a piece of cardboard or similar. We suggest that you remove the ceramic fuel effect pieces in the reverse order to that shown in section 10 of the **installer** guide.
- If necessary remove the rear ceramic wall from the bottom channel by pushing the bottom edge of the wall upwards and very slightly pulling the top forward.
- Carefully clean the surface of the ceramic fuel effect (and wall if necessary) using a soft brush.
- When refitting the ceramic fuel effect, make sure that the front locates behind the two brackets which are behind the bottom front panel of the firebox (See figure 6).
- After cleaning replace the ceramic fuel effect as shown in the relevant part of section 10 of the **installer** guide.

# OWNER GUIDE

## SERVICING AND MAINTENANCE

### **Regular maintenance.**

In order to achieve and maintain high levels of personal safety and performance efficiency it is essential that the flue terminal outside the building is kept clear of any form of obstruction.

We recommend that all gas appliances and their flues, are checked annually by a competent person (in the UK a CORGI registered installer).

In the United Kingdom it is the law that a landlord must have any gas appliance, flue and pipework which is situated in a tenant's premises checked for safety at least every twelve months.

### **Servicing.**

- Servicing can be carried out either by a Baxi Fires Division Service engineer or a CORGI registered installer.
- If you require your fire to be serviced, please contact **Baxi Fires Division Service** on **08706 090 081**

### **IMPORTANT**

**To help us quickly help you, please try to have the following information available before you contact us:**

- **Type of fire.**
- **Model/Name.**
- **Serial Number (This can be found on a label tied below the firebox and is visible when the bottom cover is removed).**

**You will also be asked for the fault, problem or request plus your Post Code.**

- If you wish to replace the ceramic fuel effect or ceramic rear wall, spare parts are available nationwide via the '**interpart** stockist network'. For your local stockist consult Yellow pages under Central Heating.
- **When fitting replacement parts it is important that only Baxi Fires Division approved parts are used for maximum safety.**

# OWNER GUIDE

## USEFUL TELEPHONE NUMBERS

General advice about gas and your gas fire:

**BAXI FIRES DIVISION TECHNICAL HELPLINE 08706 061 065.**

To report faults or arrange for your fire to be serviced:

**BAXI FIRES DIVISION SERVICE 08706 090 081.**

For sales or product information:

**BAXI FIRES DIVISION SALES 08706 061 067.**

For spares inquiries

**Spare parts are available nationwide via the 'interpart stockist network'. For your local stockist consult Yellow pages under 'Central Heating'.**

CALLERS IN THE REPUBLIC OF IRELAND

**Call 0044 8706 061 065**