

BAXI FIRES DIVISION

INSTALLER GUIDE

Model 661

POWER FLUE INSET GAS FIRE

Fitted with

Anthem,
Blenheim,
Camden,
Chic,
Dream or
Sonnet fascia



(GC No. 32-810-15)

**THIS APPLIANCE IS FOR USE WITH NATURAL GAS (G20).
WHEN CONVERTED USING CONVERSION KIT NO. 0595221 THIS
APPLIANCE IS FOR USE WITH PROPANE GAS (G31).
THIS APPLIANCE IS SUITABLE ONLY FOR INSTALLATION IN THE UNITED
KINGDOM (GB) AND THE REPUBLIC OF IRELAND (IE).**

We trust that this guide gives sufficient details to enable this appliance to be installed and maintained satisfactorily. However, if further information is required, our

Baxi Fires Division Technical Helpline will be pleased to help.

Telephone **08706 061 065** (National call rates apply in the United Kingdom)

In the Republic of Ireland telephone **0044 08706 061 065**

BAXI • VALOR • WONDERFIRE

INSTALLER: Please leave this guide with the owner

INSTALLER GUIDE

Safety First.

Baxi Fires Division fires are CE Approved and designed to meet the appropriate British Standards and Safety Marks.



Quality and Excellence.

At the heart of every Baxi Fires Division fire.

All Baxi Fires Division fires are manufactured to the highest standards of quality and excellence and are manufactured under a BS EN ISO 9001 quality system accepted by the British Standards Institute.



The Highest Standards

Baxi Fires Division is a member of the Society of British Gas Industries which works to ensure high standards of safety, quality and performance.



Careful Installation

Baxi Fires Division is a CORGI registered company. All our gas fires must be installed by a competent CORGI Registered Installer in accordance with our Installer Guide and should not be fitted directly on to a carpet or floor of combustible material.

B A X I F I R E S D I V I S I O N

Baxi Fires Division, Erdington, Birmingham B24 9QP

www.firesandstoves.co.uk

Because our policy is one of constant development and improvement, details may vary slightly from those given in this publication

INSTALLER GUIDE

CONTENTS

<u>Section</u>	<u>Heading</u>	<u>Page</u>
1.	SAFETY	4
2.	APPLIANCE DATA	4
3.	GENERAL INSTALLATION REQUIREMENTS	6
4.	APPLIANCE DIMENSIONS	12
5.	UNPACKING	14
6.	PREPARING FOR INSTALLATION	17
7.	WALL PREPARATION	17
8.	INSTALLATION OF ELECTRICS, FIREBOX AND FAN BOX	23
9.	GAS SUPPLY INSTALLATION	28
10.	FITTING THE CERAMICS	30
11.	FITTING THE FASCIA AND FIREFRONT	31
12.	CHECKS	34
	12.1 Recheck control settings.	34
	12.2 Check for spillage.	34
13.	FINAL REVIEW	36
14.	SERVICING PARTS AND REPLACEMENT	36
	14.1 Checking the aeration setting of the burner.	37
	14.2 To remove the complete burner module.	38
	14.3 To remove the pilot unit.	38
	14.4 To remove the burner from the burner module.	39
	14.5 To remove the main burner injector.	39
	14.6 To remove the gas tap/F.S.D & solenoid assembly.	39
	14.7 To remove the piezo generator.	40
	14.8 To gain access to the electrical control components.	40
	14.9 To remove the mains lead connector.	41
	14.10 To remove the fan.	41
	14.11 To remove the pressure switch.	41
	14.12 Pressure switch strip down.	42

INSTALLER GUIDE

1. SAFETY

Installer

Before continuing any further with the installation of this appliance please read the following guide to manual handling

- The lifting weight of this appliance is as below: -

	<u>Heat Engine (kg)</u>	<u>Fan Box (kg)</u>	<u>Fascia / firefront (kg)</u>	<u>Total (kg)</u>
Anthem	7.5	6.0	2.01	15.51
Blenheim	7.5	6.0	3.27	16.77
Sonnet	7.5	6.0	3.27	16.77
Camden	7.5	6.0	0.71	14.21
Chic	7.5	6.0	4.1	17.6
Dream	7.5	6.0	13.0	26.5

- One person should be sufficient to lift the fire. If for any reason this weight is considered too heavy then obtain assistance.
- When lifting always keep your back straight. Bend your legs and not your back.
- Avoid twisting at the waist. It is better to reposition your feet.
- Avoid upper body/top heavy bending. Do not lean forward or sideways whilst handling the fire.
- Always grip with the palm of the hand. Do not use the tips of fingers for support.
- Always keep the fire as close to the body as possible. This will minimise the cantilever action.
- Use gloves to provide additional grip.
- Always use assistance if required.

2. APPLIANCE DATA

This product uses fuel effect pieces and a burner compartment rear wall containing Refractory Ceramic Fibres (RCF), which are man-made vitreous silicate fibres. Excessive exposure to these materials may cause irritation to eyes, skin and respiratory tract. Consequently, it is important to take care when handling these articles to ensure that the release of dust is kept to a minimum. To ensure that the release of fibres from these RCF articles is kept to a minimum, during installation and servicing we recommend that you use a HEPA filtered vacuum to remove any dust and soot accumulated in and around the fire before and after working on the fire. When replacing these articles we recommend that the replaced items are not broken up, but are sealed within a heavy duty polythene bag, clearly labelled as RCF waste. This is not classified as “hazardous waste” and

INSTALLER GUIDE

may be disposed of at a tipping site licensed for the disposal of industrial waste. Protective clothing is not required when handling these articles, but we recommend you follow the normal hygiene rules of not smoking, eating or drinking in the work area and always wash your hands before eating or drinking.

This appliance does not contain any component manufactured from asbestos or asbestos related products.

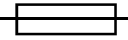
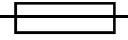
Gas	Natural (G20)	Propane (G31) *
Inlet Pressure	20mbar	37mbar
Input - Max. (Gross)	6.0kW (20,472Btu/h)	6.1kW (20,813Btu/h)
Input - Min. (Gross)	2.3kW (7,848Btu/h)	3.8kW (12,966Btu/h)
Output - Max.	3.1kW (10,577Btu/h)	3.15kW (10,748Btu/h)
Output - Min	1.1kW (3,753Btu/h)	1.8kW (6,142Btu/h)
Inlet Test Pressure (Cold)	20.0 ± 1.0mbar (8.0 ± 0.4in w.g.)	37.0 ± 1.0 mbar (14.85 ± 0.4in w.g.)
Gas Connection	8mm pipe	8mm pipe
Burner Injector	Stereomatic Cat 82 - 069	Stereomatic Size 128
Pilot & Atmosphere Sensing Device	Copreci Ref. O.D.S 21500/189	Copreci Ref. O.D.S 21500/189 fitted with RBM 180-02 injector
Ignition	Piezo Electric. Integral with Gas Tap	Piezo Electric. Integral with Gas Tap
Aeration	See section 14.1	See section 14.1
Electrical Supply	230V ~ 50Hz AC	230V ~ 50 Hz AC
Fan motor rating	55W	55W
Fuse rating	3A 	3A 

* When converted using Kit 0595221.

The appliance data label is located on a plate at the base of the fire. This can be seen by removing the fire front castings / fire front.

INSTALLER GUIDE

3. GENERAL INSTALLATION REQUIREMENTS

3.1 The installation must be in accordance with these instructions.

For the user's protection, in the United Kingdom it is the law that all gas appliances are installed by competent persons in accordance with the current edition of the Gas Safety (Installation and Use) Regulations. Failure to install the appliance correctly could lead to prosecution. The Council for the Registration of Gas Installers (CORGI) requires its members to work to recognised standards.

In the United Kingdom, all electrical supply installation must be installed in accordance with the current edition of the IEE Wiring Regulations (BS7671).

In the United Kingdom the installation must also be in accordance with:

- a) All the relevant parts of local regulations.
- b) The current edition of the Building Regulations issued by the Department of the Environment and the Welsh Office or the Building Standards (Scotland) (Consolidation) Regulations issued by the Scottish Development Department.
- c) All relevant codes of practice.

The relevant parts of the current editions of the following British Standards:-

- BS 5440 Part 1
- BS 5871 Part 2 & 3
- BS 6891

In the republic of Ireland the installation must also conform with:

- a) The current edition of IS 813 "Domestic gas installations"
- b) All relevant national and local rules in force.
- c) The current ETCI National Rules for Electrical Installation.

Where no specific instructions are given, reference should be made to the relevant British Standard Code of Practice.

3.1.2 Electrical isolation of the unit should be by means of a switched 3A fuse spur that should be readily accessible to the user, easily identifiable and sited within reach of the mains cable provided. It should only connect this appliance.

3.1.3 This fire is a fan flued appliance for installation on an outward facing wall of a conventional home which does not have a purpose built flue or chimney.

3.1.4 As supplied, the appliance is suitable for homes constructed of brick, stone, etc., the appliance can be installed into walls up to a maximum thickness as shown below. If the fire box is in front of the finished wall surface: 600mm (23 5/8in) max.

These dimensions are from the finished internal wall surface (including any surround material) to the external wall surface.

INSTALLER GUIDE

3.1.5 Installation to a timber framed building should be in accordance with the relevant sections of Institute of Gas Engineers publication IGE/UP/7 “Gas installations in timber frame buildings”. *Please note that advice should be sought before installing in a timber frame building since the alterations required may nullify any NHBC cover relating to the property. If in doubt, guidance should be requested from your local authority planning or building department.*

This appliance must be mounted with a non-combustible hearth (See figure 1) (N.B. conglomerate marble hearths are considered as non-combustible). The fire box must be mounted on a non-combustible surface level with the hearth. The hearth must project at least 300mm forward of the fire box front and be at least 625mm wide (see illustrations in “wall preparation” section). The hearth material must be at least 12mm thick. The periphery of the hearth (or fender) should be at least 50mm above floor level to discourage the placing of carpets or rugs over it.

The surface of the hearth must be sufficiently flat to enable the bottom of the front casting to be aligned horizontally. Any excessive unevenness (uneven tiles, Cotswold stone, etc.) should be rectified.

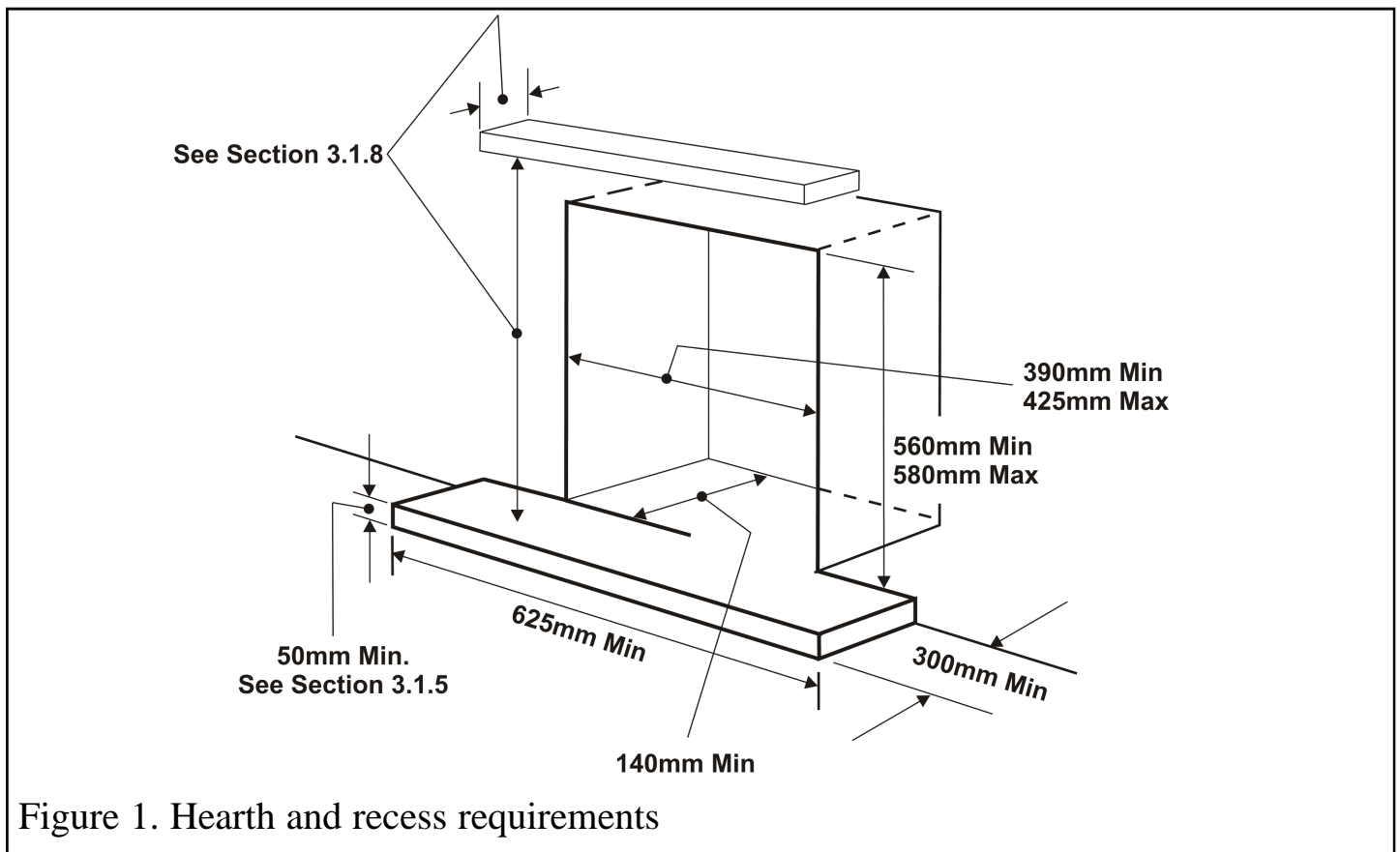

Figure 1. Hearth and recess requirements

INSTALLER GUIDE

3.1.6 The appliance must not stand on combustible materials or carpets.

The appliance must not be fitted directly against a combustible wall. If the appliance is to be fitted against a wall with combustible cladding or skirting board, such materials must be removed from the area covered by the fascia of the appliance. We suggest that the fascia is used as a template to mark the area for combustible cladding removal.

The appliance can be fitted to a purpose made proprietary class “O” 150°C surround. The opening in the surround or wall recess for the fire box must be within the limits shown in figure 1.

3.1.7. ‘Hole-in-the-wall’ Installations

It is recommended that a hearth should be installed as in figure 1.

If a reduced depth Hearth is fitted, the fire must be installed so that the distance from the base of the fireplace opening in the wall to the finished floor level is at least 88 mm. It is recommended that the reduced hearth has a depth from the fixing plane of the fire of 100mm minimum. This is necessary to support the lower front casting. The minimum shelf height will have to be taken from the base of the fireplace opening.

3.1.8 The minimum height from the top surface of the hearth to the underside of any shelf made from wood or other combustible materials is detailed below.

- For a shelf up to 150mm deep: Minimum height = 700mm.
- For a shelf deeper than 150mm: 700mm + 12.5mm for every 25mm depth over 150mm (See Graph 1).

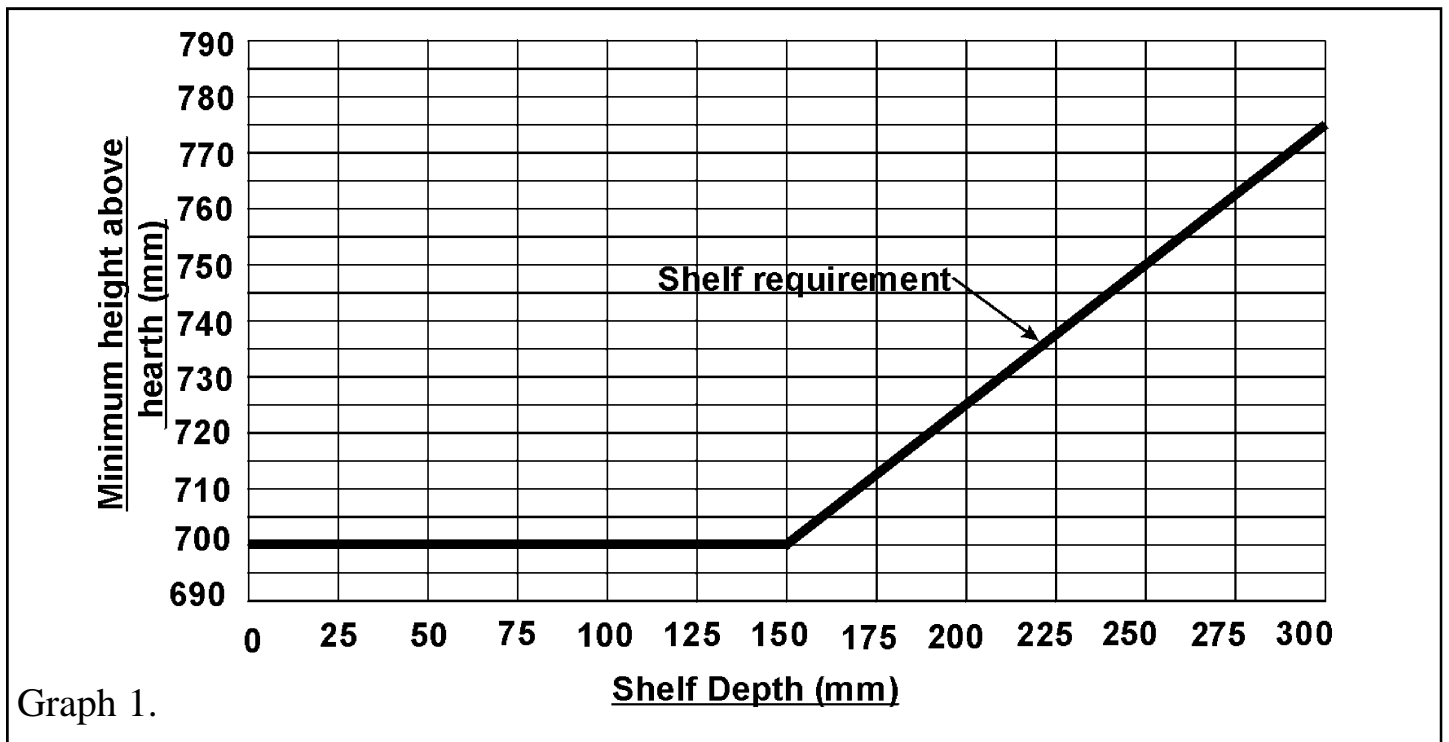

Graph 1.

INSTALLER GUIDE

3.1.9 The front face of the wall should be reasonably flat over the area that will be covered by the fire box top and side flanges to ensure a good seal. The minimum height from the top surface of the hearth to the underside of any shelf made from wood or other combustible materials is as follows:-

Note that soft wall coverings (e.g. embossed vinyl, etc.) are easily affected by heat. They may scorch or become discoloured when close to a heating appliance. Please bear this in mind when installing.

3.1.10 The appliance must not be installed in any room that contains a bath or shower or where steam is regularly present.

3.1.11 An extractor fan may only be used in the same room as this appliance, or in any area from which ventilation for the appliance is taken, if it does not affect the safe performance of the appliance. Note the spillage test requirements detailed further on in this manual. If the fan is likely to affect the appliance, the appliance must not be installed unless the fan is permanently disconnected, or provision is made to ensure that the fan and the appliance cannot be used at the same time.

A fan-powered flue system tends to depressurise the room containing the appliance.

3.1.12 Normal adventitious ventilation is usually sufficient to satisfy the ventilation requirements of this appliance. In GB reference should be made to BS 5871 Part 2 and in IE reference should be made to the current edition of IS 813 “Domestic gas Installations” which makes clear the conditions that must be met to demonstrate that sufficient ventilation is available, however the spillage check (See further on in this guide) may indicate a need for further ventilation in order to ensure that there is adequate air replacement. If necessary seek expert advice.

3.1.13 The appliance is fitted with an A.S.D (Atmosphere sensing device). If the appliance closes down after a period of operation for no apparent reason, the consumer should be informed to stop using the appliance until the installation and appliance have been thoroughly checked. The A.S.D will shut the appliance down if an unacceptable amount of harmful products of combustion accumulate. Under no circumstances should the A.S.D be altered or bypassed in any way. Only a genuine manufacturers replacement part should be fitted. The individual A.S.D components are not replaceable.

3.1.14 A fireguard complying with BS 8423 should be fitted for the protection of young children, the elderly, or the infirm.

3.1.15 The minimum allowable distance from the outside of the appliance fascia to a corner wall having combustible material or any other combustible surface which projects beyond the front of the appliance is 100mm.

For access purposes a 50mm clearance is recommended from non-combustible surfaces.

INSTALLER GUIDE

3.1.16 A concealed gas supply connection can be made through the rear panel. Visible front connection can be from the left or right side after an opening has been cut in the appropriate side of the hearth casting.

Electrical connection is from the left side.

3.2 Flue Siting

3.2.1 The flue terminal should be located so that the wind can blow freely across it at all times and where any blockage due to leaves, snow, etc. is unlikely. The minimum allowable distances from the terminal are shown in figure 3.

Note: The distances are from the edge of the vertical exit slots in the terminal not from the edges of the rectangular box (See figure 2).

3.2.2 This appliance is supplied with a terminal guard. In England and Wales, the Building Regulations require that the terminal guard is fitted if the flue terminal can come in contact with people near the building or be subject to damage. Even if the regulations do not demand it, we recommend that the guard is fitted to prevent damage or blockage of the flue system by leaves etc.

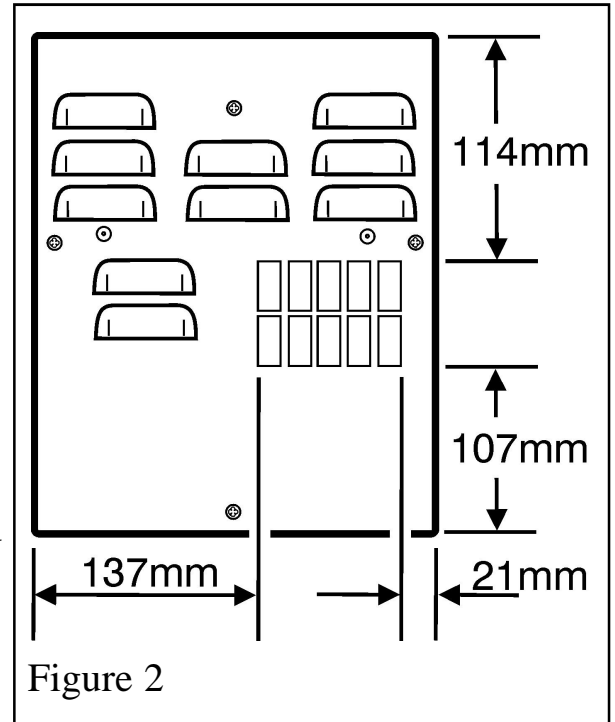

Figure 2

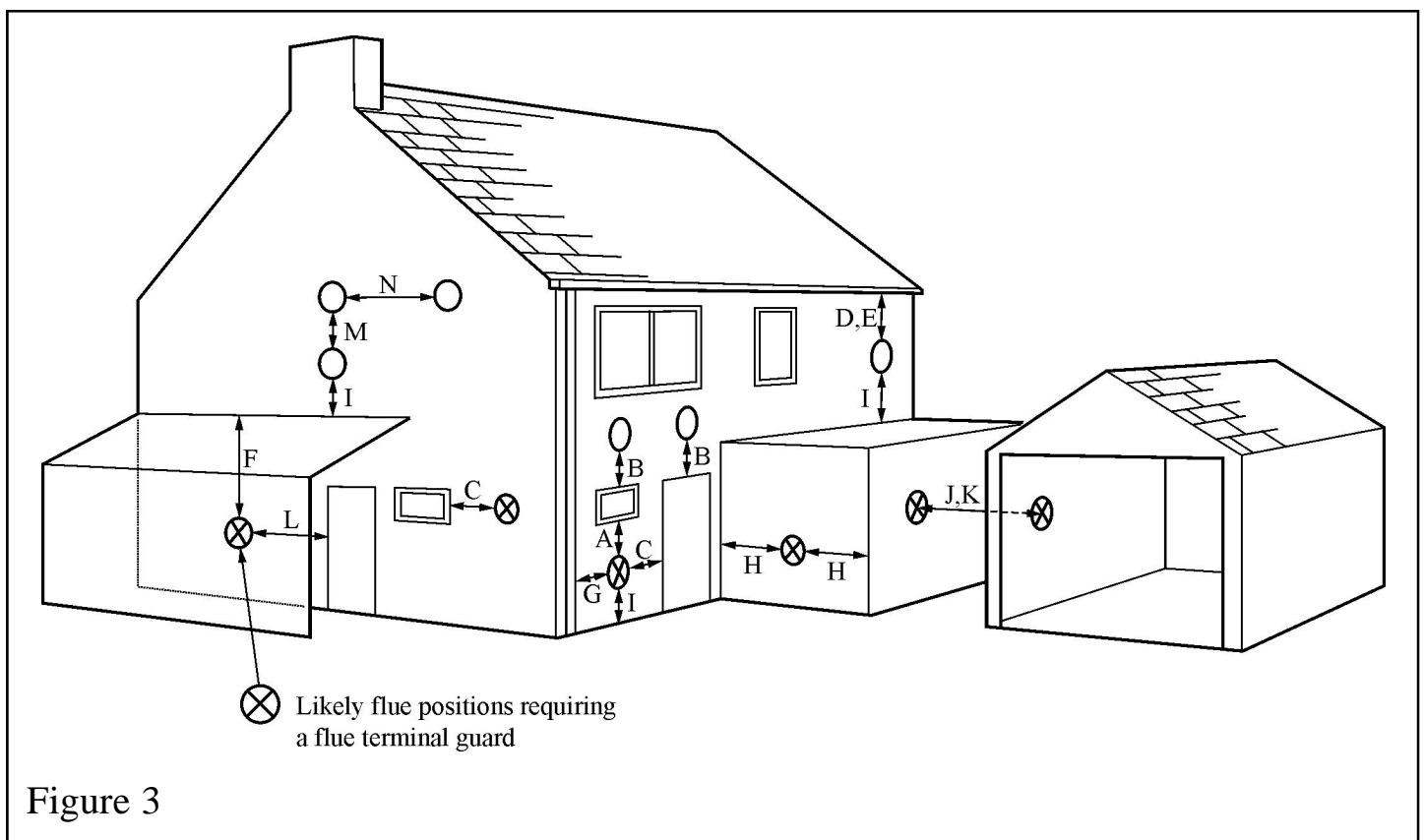

Figure 3

INSTALLER GUIDE

Dimension	Terminal Position	Minimum Distance
A*	Directly below an opening, air brick, opening window etc.	300mm
B*	Above an opening, air brick, opening window etc.	300mm
C*	Horizontally to an opening, air brick, opening window etc.	300mm
D	Below gutters, soil pipes or drain pipes	75mm
E	Below eaves	200mm
F	Below balconies or car port roof	200mm
G	From a vertical drain pipe or soil pipe	150mm
H**	From an internal or external corner	200mm
I	Above ground, roof or balcony level	300mm
J	From a surface facing the terminal	600mm
K	From a terminal facing the terminal	1200mm
L	From an opening in a car port (e.g. door, window) into dwelling	1200mm
M	Vertically from a terminal on the same wall	1500mm
N	Horizontally from a terminal on the same wall	300mm

*In addition, the terminal should not be nearer than 150mm to an opening in the building fabric formed for the purpose of accommodating a built-in element such as a window frame or door frame (See figure 3b).

** The reference to external corners does not apply to building protrusions not exceeding 450mm, such as disused chimneys on external walls.

Figure 3 continued

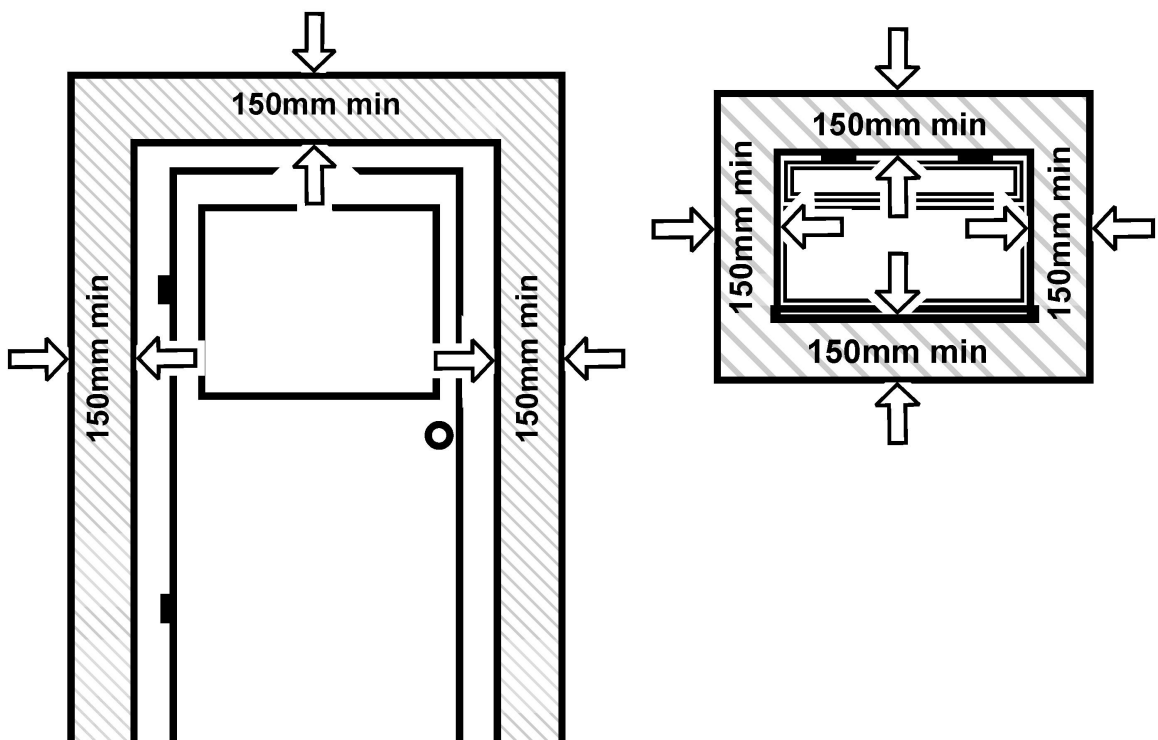
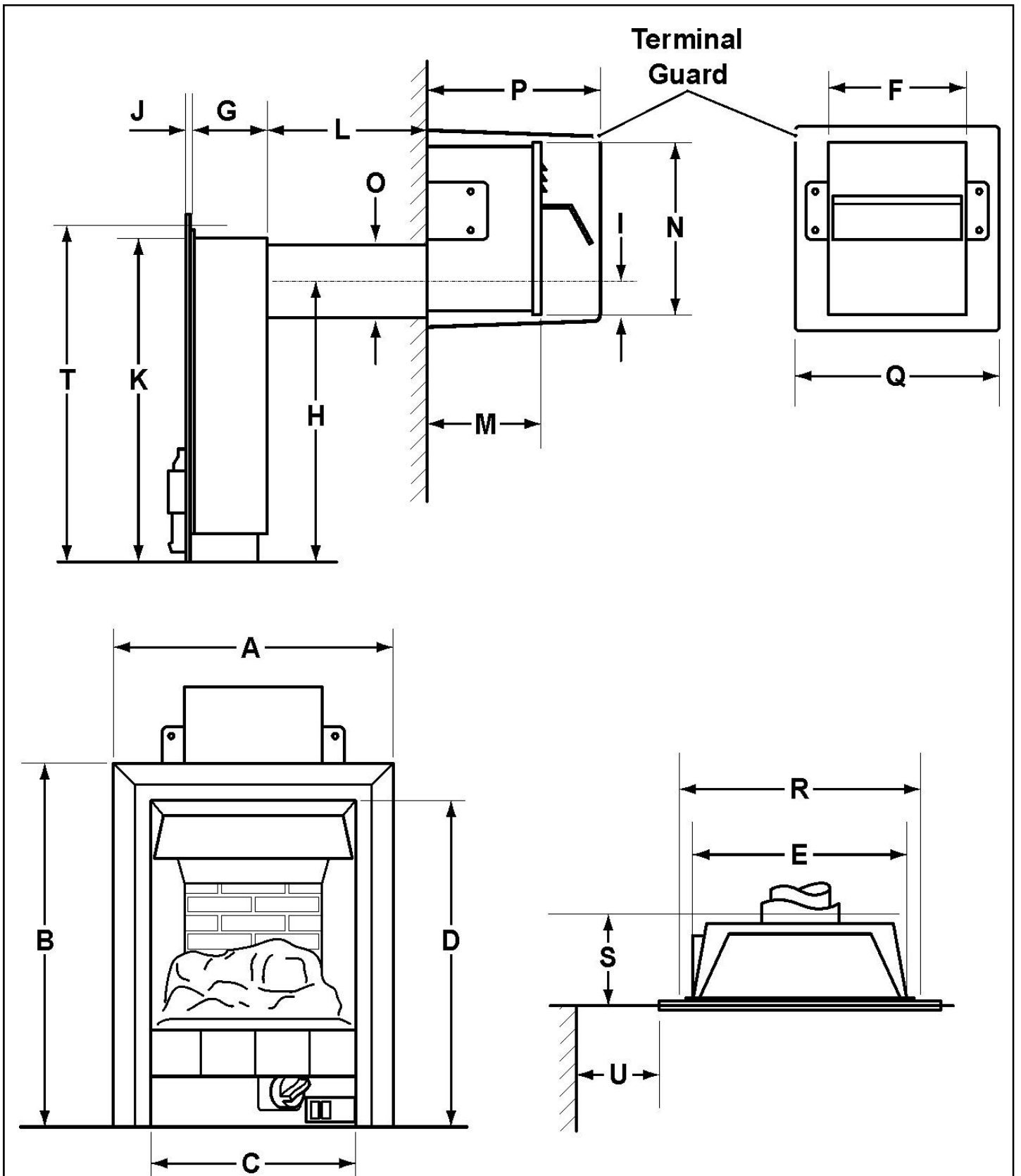

Figure 3b.

INSTALLER GUIDE



NOTE: ALL DIMENSIONS ARE APPROXIMATE AND SUBJECT TO MANUFACTURING DEVIATION

Figure 4. Appliance dimensions (Shown with Sonnet fascia).

INSTALLER GUIDE

A	<u>Sonnet, Blenheim, Camden, Anthem</u> 450mm	<u>Dream</u> 518mm	<u>Chic</u> 467mm
B	<u>Sonnet, Blenheim, Camden, Anthem</u> 585mm	<u>Dream</u> 636mm	<u>Chic</u> 600mm
C	325mm		
D	525mm		
E	350mm		
F	235mm		
G	125mm		
H	475mm		
I	53mm		
J	5mm		
K	550mm		
L	600mm Max. (Flue tube uncut) 150mm min.		
M (Fan box projection)	205mm when sited outside wall 55mm when recessed in outer wall		
N	285mm		
O (Flue tube diameter)	125mm		
P (Terminal guard)	305mm		
Q	355mm		
R (Recess width)	390mm min. 425mm max.		
S (Recess depth)	140mm min		
T (Recess height)	560mm min. 580mm max		
U (Clearance to wall etc. projecting forward of appliance firebox)	100mm min.		

INSTALLER GUIDE

5. UNPACKING

The pack contains:

- 1 Burner & firebox unit with attached Rockwool jacket
- 1 Fan box assembly
- 1 Flue duct
- 1 Ceramic fuel effect pack (Not shown)
- 1 Burner tray trim (Not supplied on Anthem model) (On Chic models this is supplied in the fascia pack)
- 1 Terminal weather shield
- 1 Literature pack
- 1 Smoke match tube
- 2 Rolls aluminium tape
- 1 Nut & olive for 8mm inlet pipe (Supplied as part of the inlet 'T' connector)
- 1 Retention kit (4 wall plugs, 4 eye bolts, 2 tension adjusters and two cable assemblies).
- 10 Wall plugs
- 10 Woodscrews
- 2 Taptite screws (For fan box)
- 1 Rockwool jacket top section
- 2 Cable ties
- 1 Firebox fixing bracket assembly (2 brackets & 2 self tapping screws)
- 1 Terminal guard fixing assembly (4 screws & washers) (Terminal guard in separate pack)
- 2 Black machine screws (For fascia fitting)

Section 2 - Anthem:

- 1 Fascia pack (Contains three separate pieces)
- 1 Firefront casting
- 1 Bottom front cover casting
- 2 Firefront casting brackets.

Section 2 - Dream:

- 1 Fascia
- 1 Firefront casting
- 1 Bottom front cover casting

Section 2 - Camden:

- 1 Fascia pack (Contains three separate pieces and six magnets)
- 1 Firefront

Section 2 - Sonnet (Black & Chrome):

The fascia is supplied fitted to the hotbox.

- 1 Firefront casting
- 1 Bottom front cover casting

Section 2 - Blenheim & Sonnet (Brass):

- 1 Fascia pack (Contains three separate pieces)
- 1 Firefront casting
- 1 Bottom front cover casting

Section 2 - Chic:

- 1 Fascia

Carefully remove the contents. Take special care in handling the ceramic fireback and the ceramic fuel effect pieces. Check that the listed parts are present and in good condition.

INSTALLER GUIDE

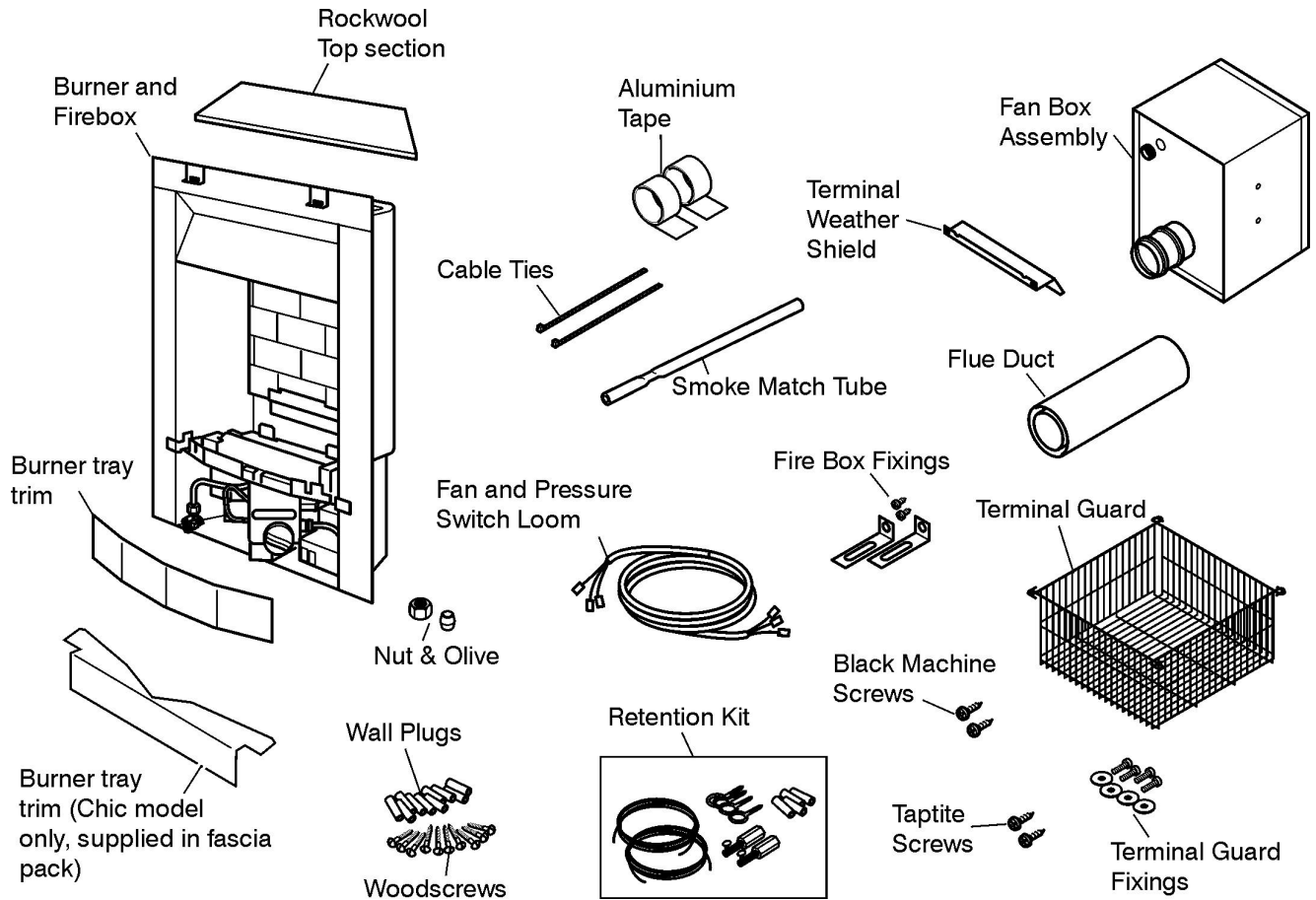

Dream

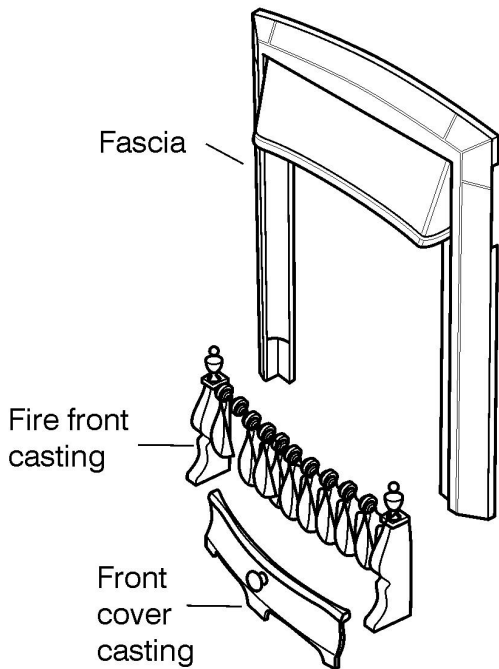

Chic

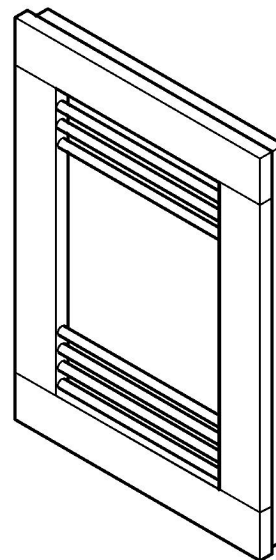
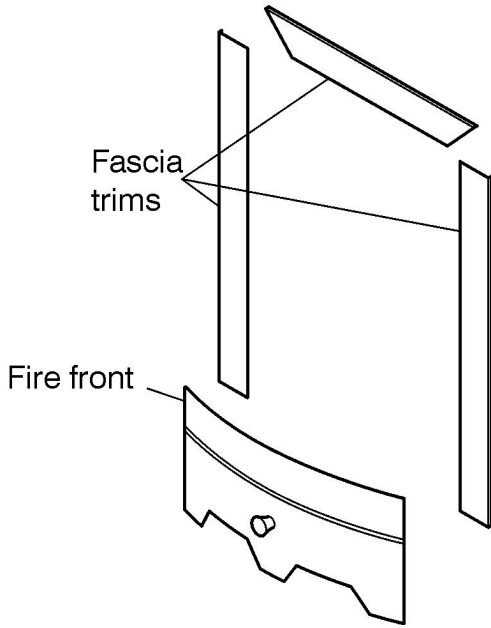

Figure 5. Contents

INSTALLER GUIDE

Camden



Anthem

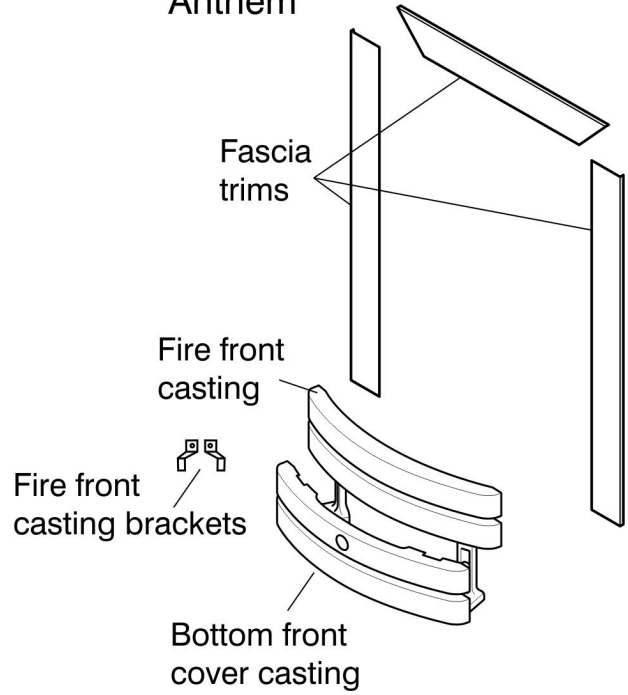

Blenheim and Sonnet

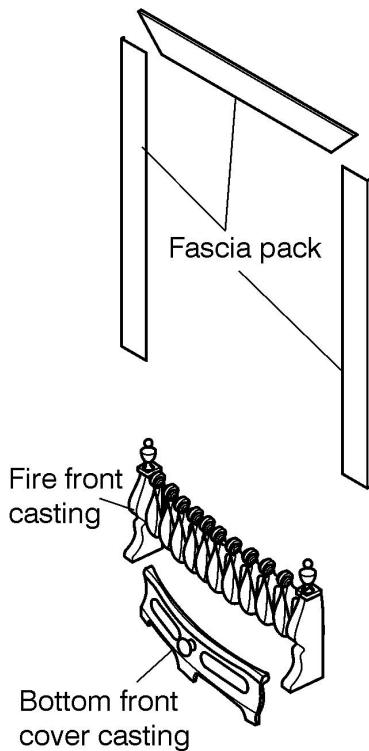

Blenheim & Sonnet (Brass)

Fascia
(Supplied fitted to hotbox)

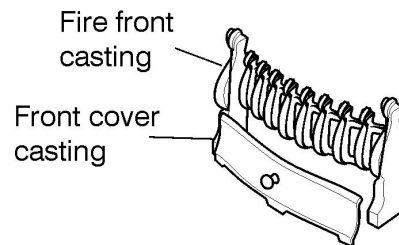

Sonnet (Black) & Sonnet (Chrome)

Figure 5. Contents continued.

INSTALLER GUIDE

6. PREPARING FOR INSTALLATION

Check ignition spark.

Before attempting to install, it is worth checking that the ignition system performs satisfactorily.

- Set the control knob to the off position.
- Depress the control knob and rotate it anticlockwise to the pilot ignition position. A 'click' will be heard as the integral piezo operates. A spark should be seen between the electrode and pilot tip (See figure 6).

If there is no spark check the following: -

- Ensure that the electrode lead is connected to the terminal at the base of the electrode.
- If the above is correct, check for damage to the electrode lead.

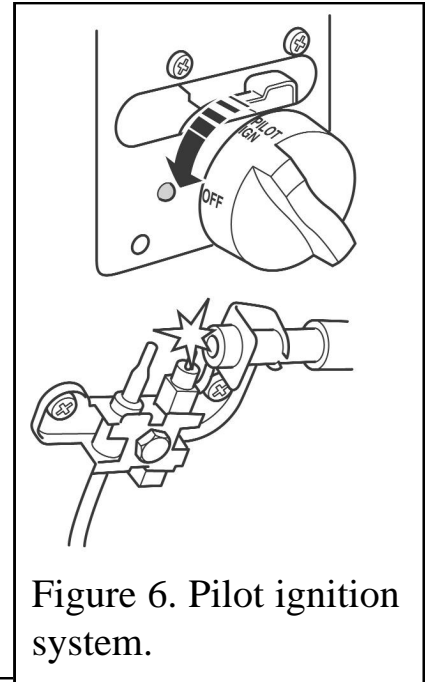

Figure 6. Pilot ignition system.

In the majority of cases, the burner unit will need to be detached. Detach the burner unit from the convection box by removing two screws (See figure 7). Carefully lift the burner unit out from the hotbox and place immediately in front of the hotbox. Do not attempt to lift the burner module away from the front of the firebox as this may damage the solenoid leads. Disconnect the solenoid leads from the control box.

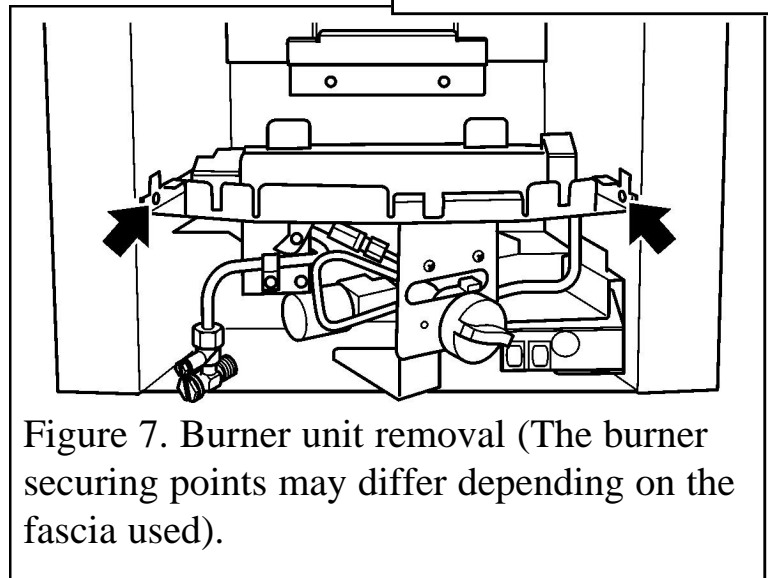

Figure 7. Burner unit removal (The burner securing points may differ depending on the fascia used).

7. WALL PREPARATION

7.1 General.

1. Make sure that the installation will comply with all the relevant requirements in part 3 of this manual.
2. Attempt to keep the hole sizes as close to the minimum dimensions as possible in order to minimise the sealing required.
3. Make sure that the damp course or any electrical wiring, piping etc. in the wall is not affected when cutting the installation hole.
4. Any gas supply pipe installed in the wall, floor or cavity of a cavity wall must be continuous and enclosed in a factory fitted gas tight sleeve (Ref: Gas safety (Installation & Use) Regulations 1994 as amended & Certificate of exemption no.1 1996)

INSTALLER GUIDE

7.2 Brick, stone etc. building. Main case in front of wall (Figure 8).

1. This installation is for use with a fire surround or false chimney breast having a minimum depth of 140mm (5 1/2in.). The flue length may be cut to suit the wall thickness. (See prepare flue assembly section) Combustible material within a false chimney breast must be at least 75mm from the fire box.
2. The non-combustible hearth must project at least 300mm in front of the convection box front flanges and be at least 625mm wide (Figures 1 & 8).
3. The cavity should be sealed where the flue tube hole has been cut. We recommend filling fully across the cavity with Rockwool or equivalent to at least 100mm around the opening (See figure 12)

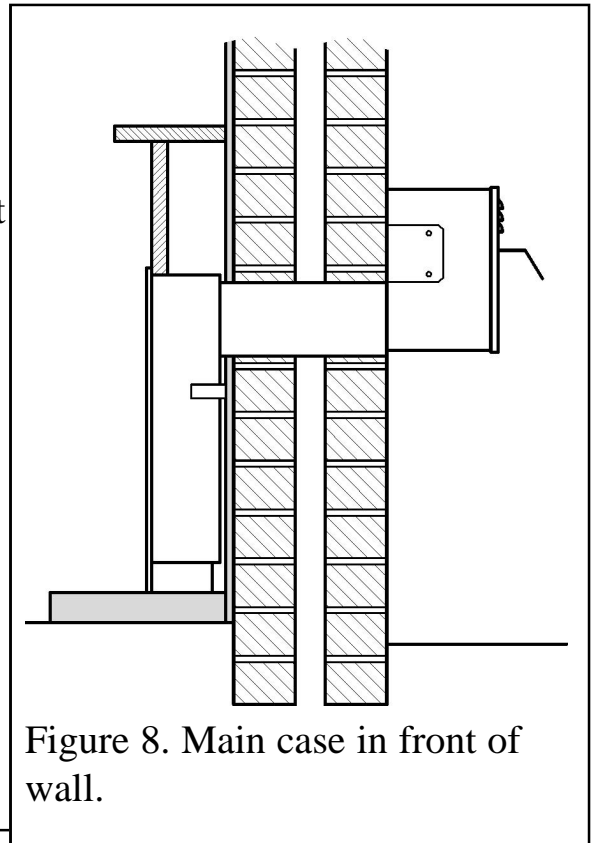

Figure 8. Main case in front of wall.

7.3 Brick, stone etc. building. Main case recessed into wall. (Figure 9)

1. This installation has the fire box recessed into the inner wall of the building. The front flanges of the fire box and the appliance fascia will abut the front surface of the wall.
2. The non-combustible hearth must project at least 300mm in front of the convection box front flanges and be at least 625mm wide (Figure 1). The recess in the inner wall for the fire box should be to the size shown in figure 1. The bottom of this recess should be at the same level as the top surface of the hearth. *A lintel may be required above the recess for the fire box. If in doubt, seek expert building advice before commencing to cut the recess.*

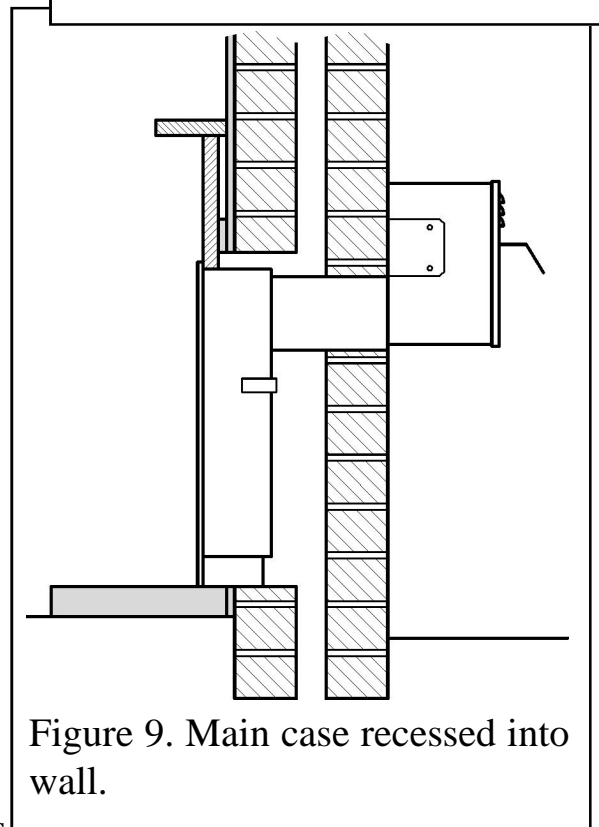

Figure 9. Main case recessed into wall.

Whenever a lintel is required to support the recess in the inner leaf of a brick/blockwork building, refer to the following section (See figures 10 and 11).

INSTALLER GUIDE

7.4 Lintel installation.

1. The lintel should be either steel (Catnic) or reinforced precast concrete. It should be 750mm long x 75mm deep x inner leaf thickness.

2. The opening should be, as near as possible, centrally below a joint in the inner leaf block.

3. Cut out the opening for the lintel.

Where cutting through masonry, drill pilot holes and then cut out the slot using a mechanical cutter. This will minimise damage to the surrounding structure.

4. Insert the lintel. Bed the lintel on mortar.

Don't dry bed. Slate pin to ensure the lintel and structure above is secure and safe

5. Make the opening below the lintel by removing the masonry and clearing debris. If the cavity has loose fill (e.g. granular) insulation material, pack the edges of the opening with Rockwool as you proceed to hold back the insulating material.

6. The wall cavity must not be bridged other than by the flue tube assembly. The fire box must not project into the cavity between the inner and outer walls by more than 10mm.

See wall preparation for flue tube.

The cavity should be sealed where the opening has been cut. We recommend filling fully across the cavity with Rockwool or equivalent to at least 100mm all around the flue tube. Fill at the bottom of the opening to the level of the hearth/fireplace floor. It may be simplest to back fill the cavity with the insulation material and then cut through the insulation to the size of the flue box hole.

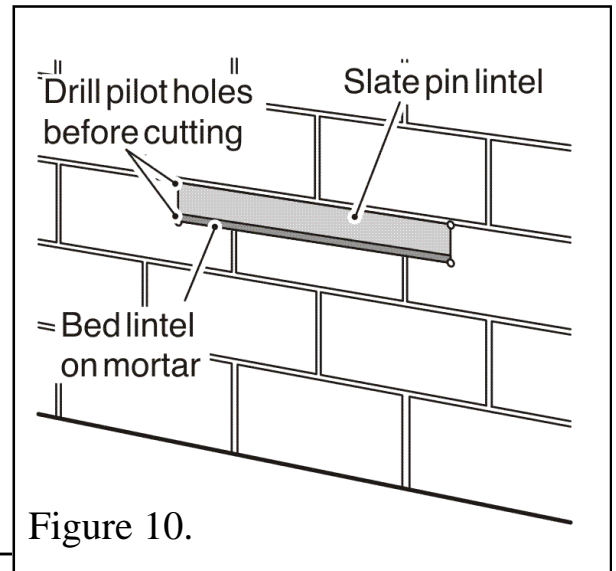

Figure 10.

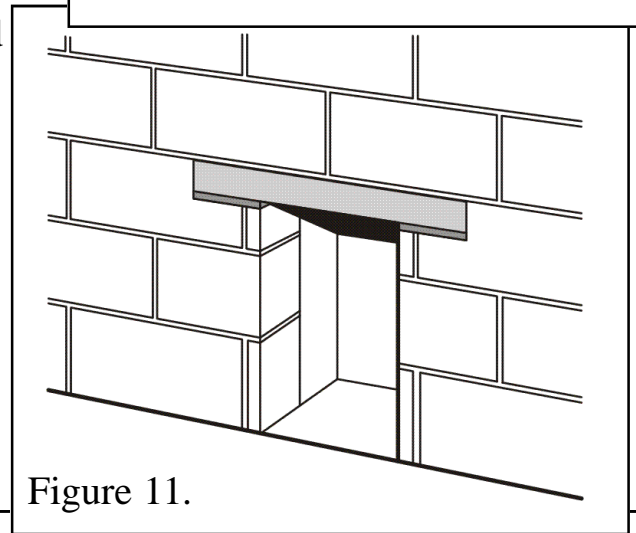

Figure 11.

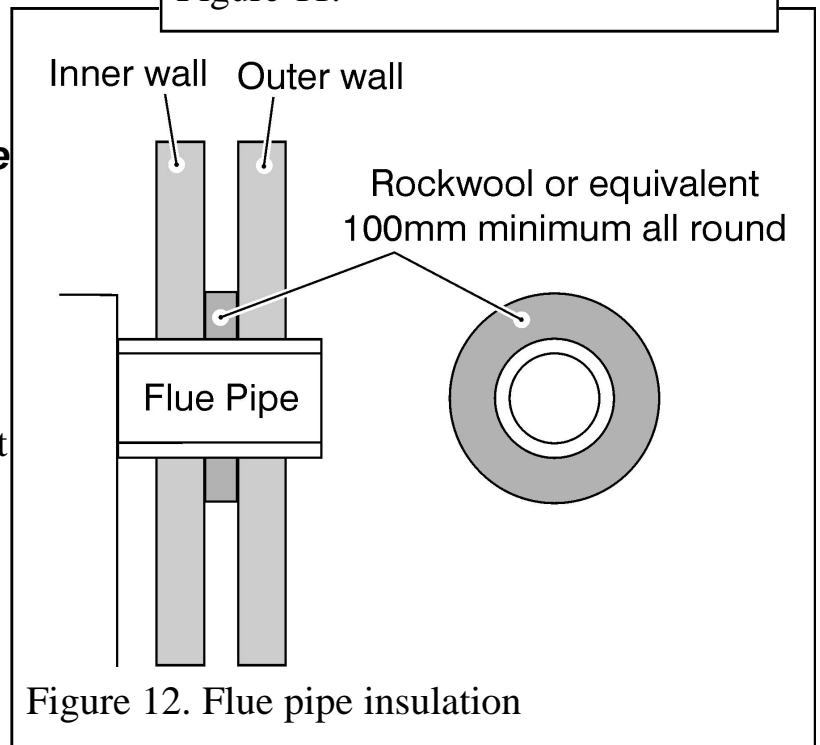

Figure 12. Flue pipe insulation

INSTALLER GUIDE

7.5 Timber frame building. Firebox in front of wall.

This installation is for use in timber framed buildings in conjunction with a fire surround having a minimum depth of 153mm (6 inch).

1. The non-combustible hearth must project at least 300mm in front of the convection box flanges and be at least 625mm wide. For this type of installation the hearth must be at least 50mm thick over its total area (Figure 1).

Installation must be in accordance with the current edition of Institute of Gas Engineers publication IGE/UP/7.

2. The back surface of the firebox and flue tube assembly must be separated from the timber frame by 25mm of non-combustible material.

This can consist of the usual

13mm plasterboard wall lining plus 12mm of “Superlux” or similar non-combustible material. The opening should be between studs.

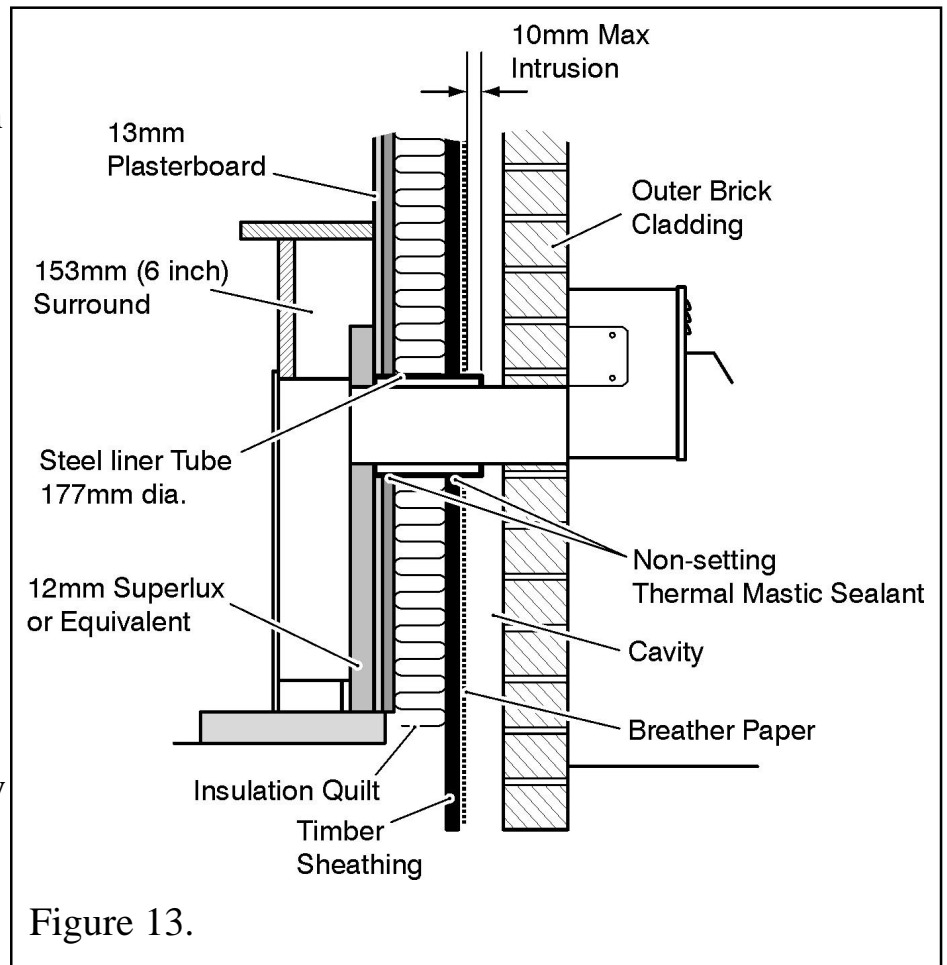

7.6 Wall preparation for flue tube.

1. The flue must be installed so that it is at right angles to the back panel of the fire all round the flue circumference. The fire itself should be fitted vertically against a flat wall. Where this is difficult to achieve due to building inaccuracies care should be taken to ensure that the back of the fire is not stressed in any way due to distortion of the assembly when tightening the fixing screws. Where necessary, non-combustible packing pieces should be used to provide a satisfactory fixing surface.

2. Before cutting the hole in the wall make sure that the height to the top surface of the finished floor is known. The height from this surface to the flue hole centre is shown in figure 14.

3. If a loose hearth or plinth is to be used, the height from its top surface must be used when determining the flue height.

4. Place dust sheets on the floor and over any furnishings etc.

5. Make sure that the centre of the flue hole is as shown in figure 14.

6. Cut the hole for the flue unit.

INSTALLER GUIDE

7.7 Core drilling.

1. Drill a pilot hole through the wall. Inspect the hole to ensure that it is in the brickwork and not in mortar. If it is in mortar, it is advisable to reposition the hole approximately 25mm away (Ensuring that all other clearances to firebox are complied with). Remember to reposition the screw fixing holes.
2. Drill the flue hole with a 5in. (127mm) core drill.
3. Remove any combustible wall cladding material from the area behind the firebox as described previously.

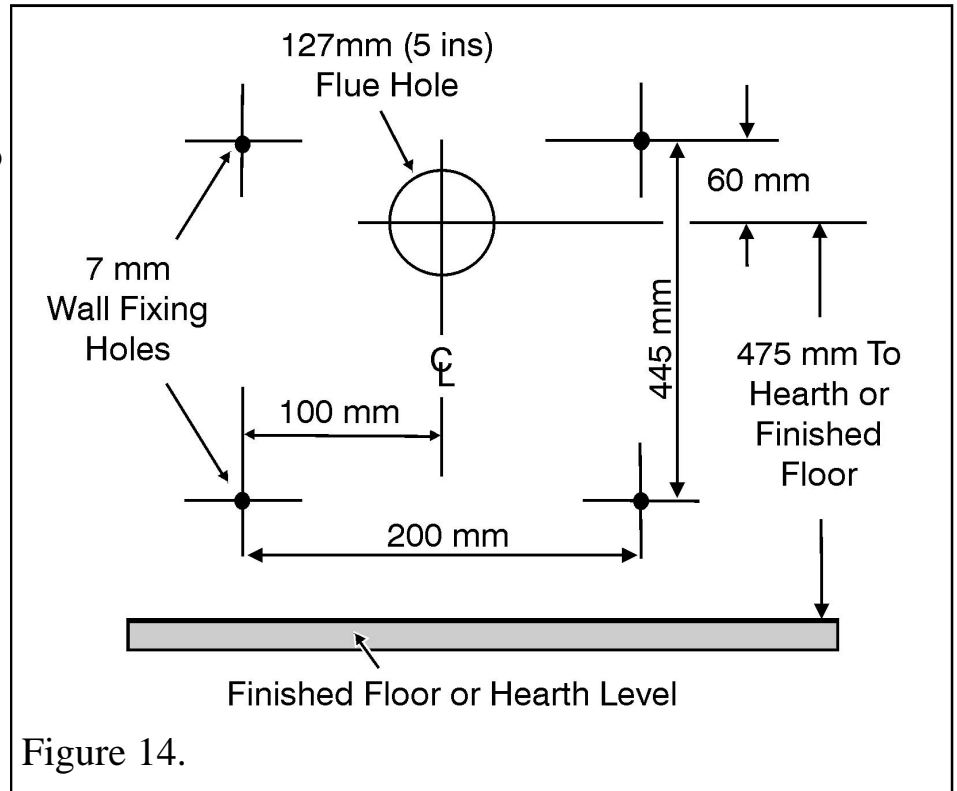

7.8 Hammer and chisel cutting.

1. Mark a 127mm (5in) diameter circle for the flue hole. Chisel out the area marked.

It may be necessary to make good both the internal and external wall faces. To achieve a neat finish and to make any future removal of the flue unit easier, it is recommended that a cardboard cylinder is formed around the flue unit and inserted in the hole whilst making good. Remove the cardboard cylinder after making good.

7.9 Combustible walls (wood, fibreboard, plasterboard etc.).

1. Building regulations require that the outer surface of the flue tube and terminal must not be closer than 25mm to combustible material and must be lined with steel sleeve not less than 0.5mm thick (See figure 13). The sleeve can be made by coiling a piece of sheet steel to between 125mm & 127mm outside dia. and fitting it to the combustible parts of the construction.
2. Mark out and cut a hole 177mm diameter through the plasterboard.
3. Cut a hole of about 165mm in the vapour barrier. Clear the insulation quilt from the hole area and cut a 177mm dia. hole in the timber sheathing and breather paper.
4. Drill a 127mm diameter hole through a non-combustible (brick etc.) outer wall.
5. Fit the steel sleeve. The sleeve should not protrude more than 10mm into the cavity. The sleeve should be sealed to the inner leaf of the wall at both ends with a non-setting thermal mastic sealant.
6. If the outer wall is combustible drill a 177mm hole and fit the liner sleeve through to this wall.

INSTALLER GUIDE

7. Cover the hole with a steel plate size 500mm (Vertical) x 235mm, not less than 1.5mm thick with a 127mm diameter hole in the middle. Fix with suitable screws and plugs.
8. Where the whole wall is of combustible material a non-corrosive plate 455mm square with a 127mm diameter hole in the centre must be fitted to the outer face of the wall.
9. The area immediately behind the firebox must be separated from the combustible elements of the inner wall by 25mm thickness of non combustible material. This can consist of the usual 13mm plasterboard wall lining plus 12mm of “Superlux” or similar non-combustible material (See figure 13).

7.10 Fixing the appliance in position.

There are two methods of fixing that may be used:

1. Cable Retention
2. Use of fixing brackets

If the fire is to be fitted in front of the wall, then fixing brackets may be used. If this is the case, then refer to the section entitled “Securing firebox to wall using fixing brackets” further on in this manual.

If the cable fixing method is used, it will be necessary to install the eyebolts now. This is achieved as follows :

1. Working from the centre of the flue hole, mark up four holes as shown in figure 14.
2. Drill the fixing holes to a minimum depth of 42mm using a 7mm masonry drill.
3. Insert four fibre wallplugs (supplied in loose parts pack).
4. Now firmly screw in four eyebolts (also supplied in loose parts pack).

7.10.1 Provision for main loom.

It may be necessary to cut a groove in the flue hole to ensure that there is adequate clearance for both the flue tube and the electrical loom. A trial installation of both is recommended.

The groove should be cut in the lower right hand side of the hole (Electrical control assembly side). (See figure 15).

Alternatively, a separate electronic cable access hole of 25mm may be preferred, and should be positioned as shown in figure 16.

7.11 Prepare flue assembly.

1. Measure the total wall thickness from the outside surface to the inside face. Add 18mm to

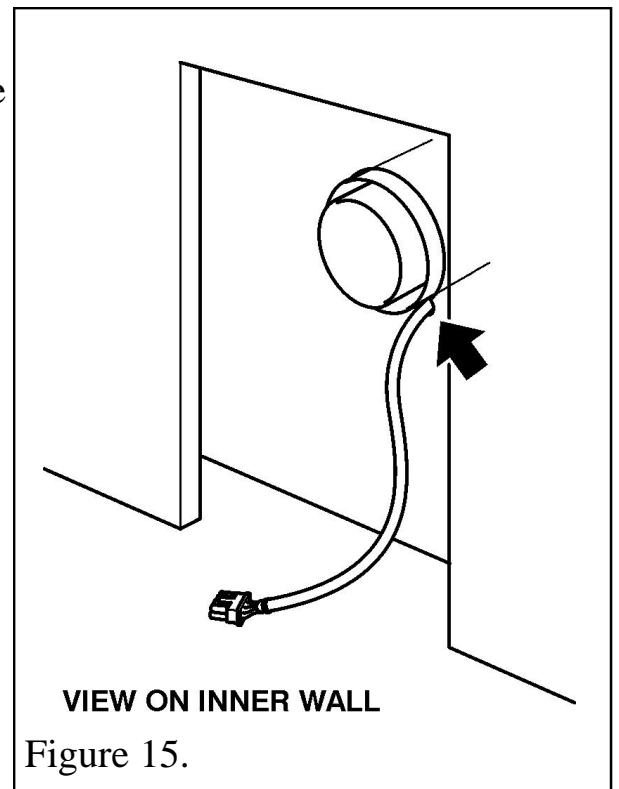

INSTALLER GUIDE

this measurement to obtain the correct length of flue unit required. This measurement is for surface mounted fan box assemblies. Care should be taken if the fan box is to be recessed. *The fan box is not intended to be recessed into a timber framed building.*

2. Measure the flue length from the inner flue tube at the appliance end (staggered end) and mark the cut point on the outer pipe of the fan end (Pipes are flush).

3. Insert the polystyrene ring

between the inner and outer tubes to support them and cut both tubes squarely at the marked distance. *Remember cut only the fan end, the flush fitting end.*

Important: **Remove all packaging** from the flue unit. Remove all polystyrene from the flue unit after cutting.

4. Now the flue tube is ready for installation.

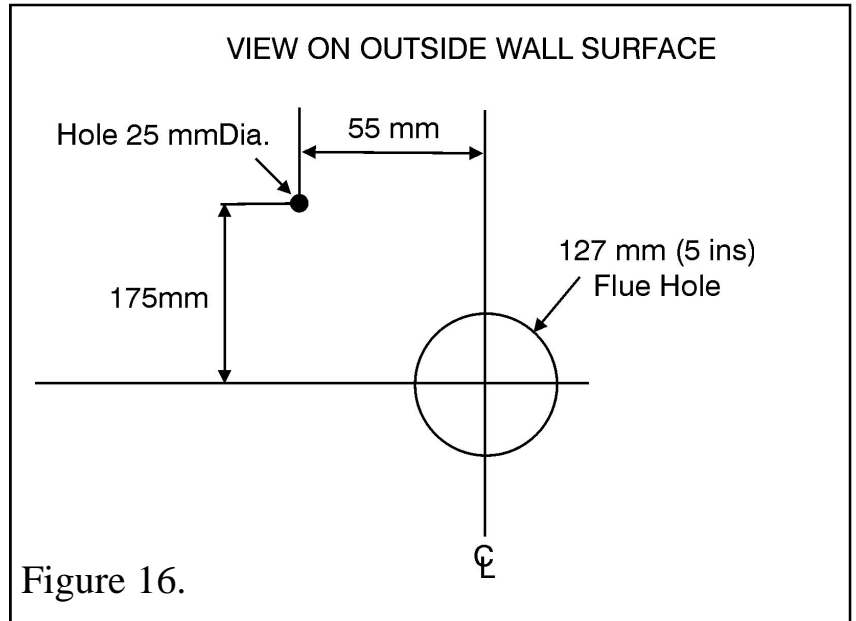

8. INSTALLATION OF ELECTRICS, FIREBOX AND FAN BOX

Important : Under no circumstances should the electrical loom be fed between the inner and outer sections of the flue tube.

Ensure the mains electrical supply to the appliance is in place *and is isolated*.

Important : *We strongly recommend that a dust mask and protective gloves are worn in order to minimise exposure to Rockwool fibre whilst fitting the insulation jacket .*

Ensure the Rockwool insulation jacket is securely positioned on the back of the firebox. Fit the top part of the jacket to the top of the firebox by securing with two tags as shown in figure 21.

Note : Use aluminium tape provided to seal adjoining edges of the jacket as shown, unless cable fixing method is to be used, in which case, tape up after cables are in position.

INSTALLER GUIDE

8.1 Fan box installation preparation.

Before installation can proceed it will be necessary to remove the fan unit from the fan box.

1. Remove the three cover retaining screws and withdraw the fan unit (See figure 17).

Check inside for any loose unwanted packaging

2. For transit purposes the weather shield is supplied as a loose part, remove this from the loose parts pack and fit to the fan box as follows .

3. If the fan box is to be sited totally outside the wall fit the brackets with the short flanges flush with the air intake end of the fan box (See figure 18).

If the fan box is to be recessed by 150mm into the wall then fit the brackets with the short legs 50mm from the air outlet face of the fan box (See figure 19).

4. Use a hammer and chisel to cut an aperture of 230mm by 280mm (Vertical).

5. Place the fan box in position with the spigot located in the flue pipe. Ensure the box is firmly located and correctly aligned against the wall, and mark off the four screw fixing positions on the wall.

6. Remove the fan box, Drill at the marked positions four holes using a number 10 drill and plug.

7. Locate the cable ties supplied in the loose parts pack as in figure 20.

8. Feed the wiring loom through the hole in the wall (See section 7.10.1).

9. Obtain the previously prepared flue tube and attach to the spigot on the back of the firebox.

Ensure that the flue pipe is not fitted in reverse. i.e. The stepped end is the firebox end.

Now offer the complete assembly as a unit to the wall.

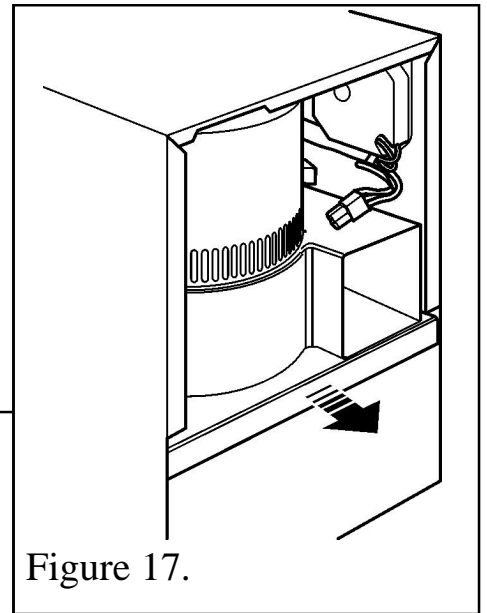

Figure 17.

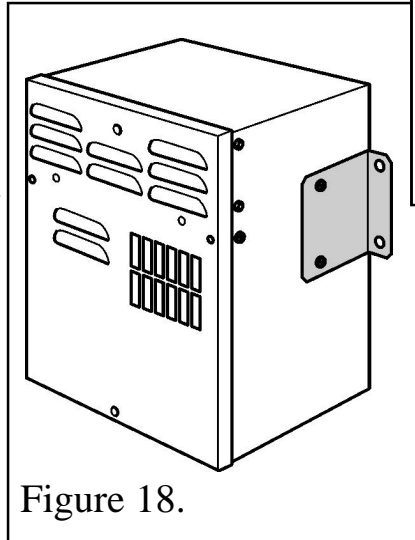

Figure 18.

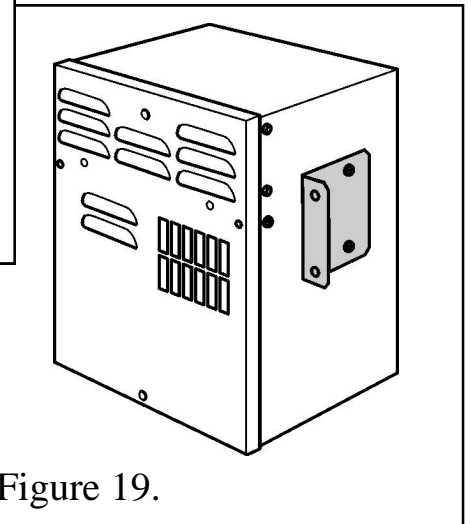

Figure 19.

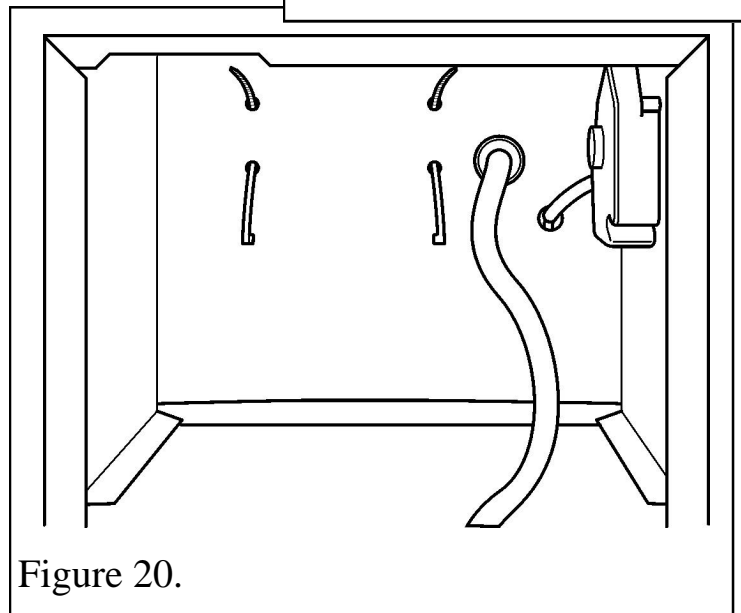

Figure 20.

INSTALLER GUIDE

Take care not to damage the wiring loom as the flue pipe is inserted through the wall.
10. Connect the wiring loom at the firebox end, the eight pin connector is located on the lower right hand side of the appliance. **It is important that approximately 250mm of slack cable exists at the base of the firebox. This slack is necessary to allow removal of the electrical control unit in future servicing.**

8.2 Securing firebox to wall - cable retention.

See section 9.1 'Gas supply connection'.

1. Assemble retention cables into firebox.
2. Insert cables into cable anchor points in upper rear of firebox and then tape together adjoining edges of the jacket as shown in figure 21.
3. Offer the firebox up to the wall and feed the retention cable through the installed eyebolts.
4. Return the cables through the holes provided at the lower back of the firebox.
5. Assemble adjusters and tension as in figure 22.

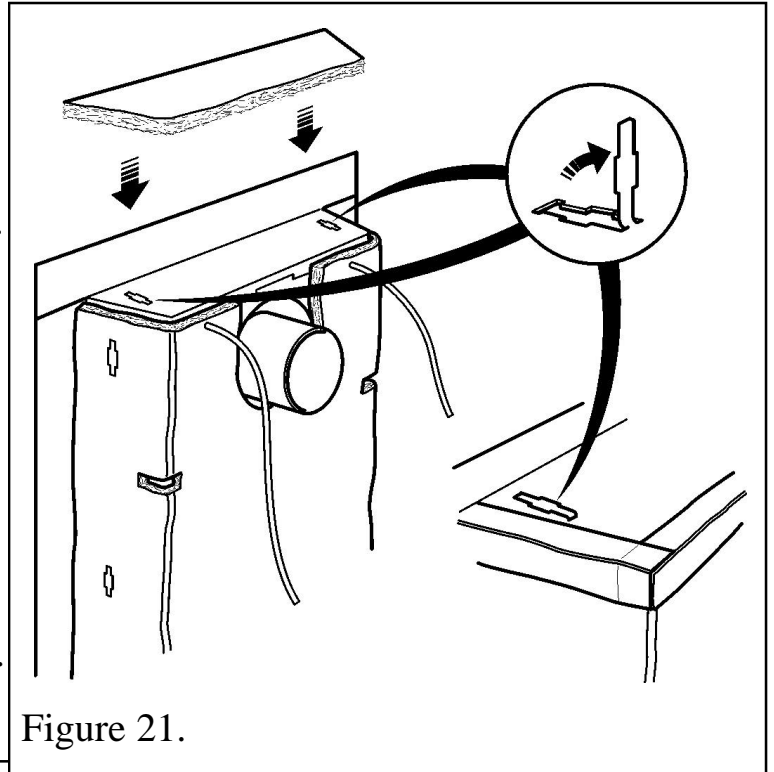

Figure 21.

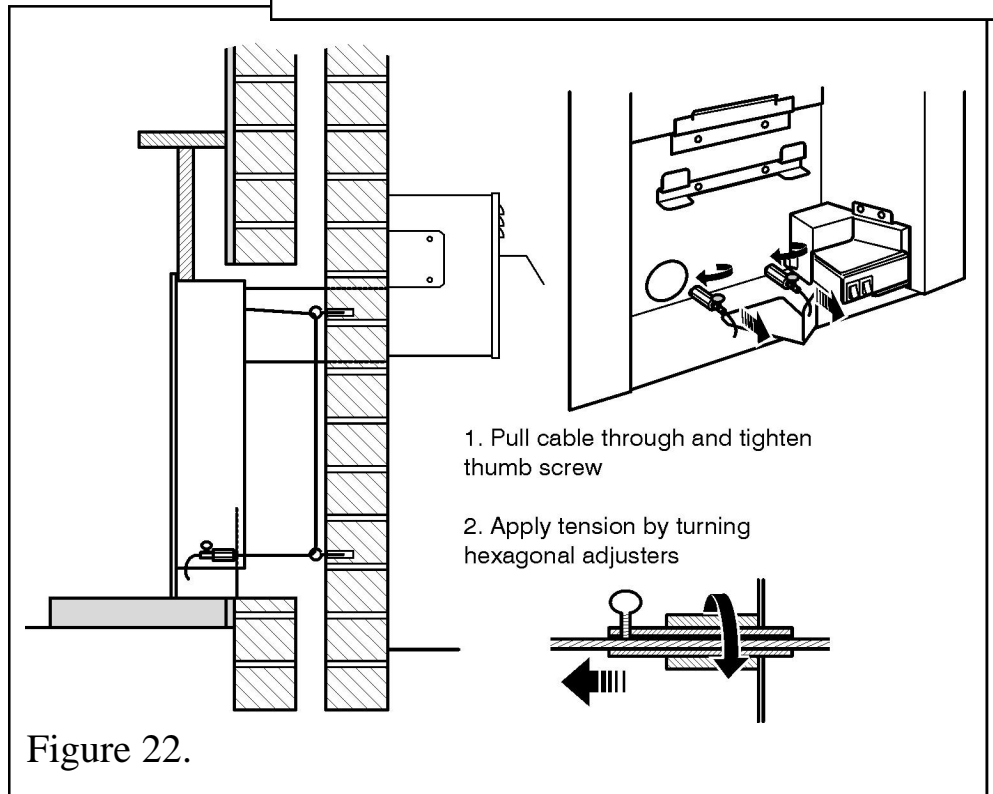

Figure 22.

INSTALLER GUIDE

8.3 Securing firebox to wall using fixing brackets.

See section 9.1 'Gas supply connection'.

1. Loosely assemble the two fixing brackets provided (See figure 23) using the screws provided.
2. Offer fire up to wall.
3. Establish the final location of firebox, and secure fixing brackets accordingly.
4. Mark off the wall, drill two holes using no.10 drill bit. Insert wall plugs.
5. Secure using wood screws provided.

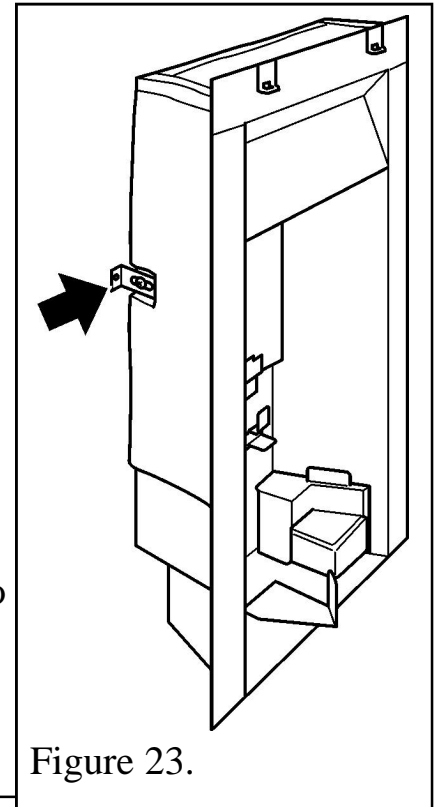

Figure 23.

8.4 Completing the fan box installation.

1. Offer the fan box to the wall. Locate the fan box spigot into the flue and secure the fan box to the wall using the screws supplied. Be careful not to trap or damage the wiring loom.
2. Make good around the fan box, ensuring that no gaps appear between the box and wall.
3. Stow the excess cable as shown in figure 24. Leave about 200mm of free length for fan motor connection. Secure the stowed cable inside the fan box with cable ties.
4. Replace the fan unit taking care not to snag or otherwise damage the electrical fittings. Connect the cable loom to the fan unit (See figure 25)

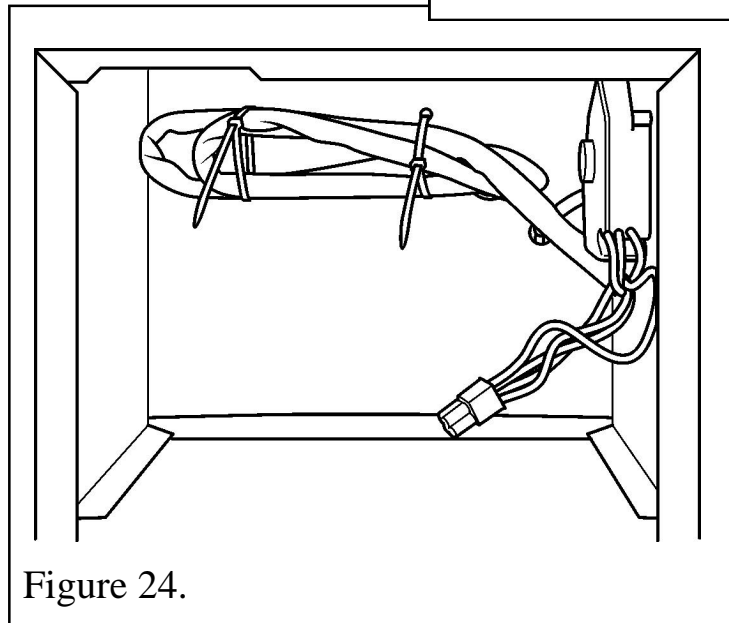

Figure 24.

5. Upon completion of cable installation ensure that the loom and cables do not touch the horizontal surface of the fan casing immediately above the rectangular flue gas outlet. If cables run close or are in contact with this surface they should be held clear using the additional cable ties provided.
6. Upon completion ensure a neat and tidy installation before replacing the fan box cover .
7. Replace the fan box cover and weather shield (See figure 26) and secure using the three screws provided.

INSTALLER GUIDE

8.5 Electrical installation.

1. Install a power supply at a switched fuse having a minimum separation of 3mm at all poles. The spur should be readily accessible to the user, easily identifiable and preferably sited adjacent to the appliance. It should only connect this appliance.

WARNING : *Ensure the supply is isolated before proceeding.*

8.6 Refitting the burner unit.

Replacing the burner unit, is the reverse of removal. See section 6 and figure 7.

8.7 Electrical test.

- Switch on power supply to the appliance.
- The control box is mounted under the burner module. Press the “on” switch. Within a few seconds, the Fan motor should start and the neon indicator will light. The neon light is an indication that the fan is in ‘boost’ mode.
- After a few seconds the fan motor should reduce in speed and be operating at ‘normal’ speed. The neon indicator will no longer be illuminated.
- Press the “off” switch. The fan should stop.
- The fan has a “boost” speed intended to clear any minor exhaust obstructions. To check its operation:
 - i. Switch the fan on.
 - ii. Go outside the building and place a hand over the rectangular exhaust outlet of the terminal. The fan should be heard to increase to “boost” speed within approximately two seconds.
 - iii. Remove the hand. The fan should revert to normal speed after approximately three seconds.
- The unit includes a blocked flue sensor system. To check its operation:

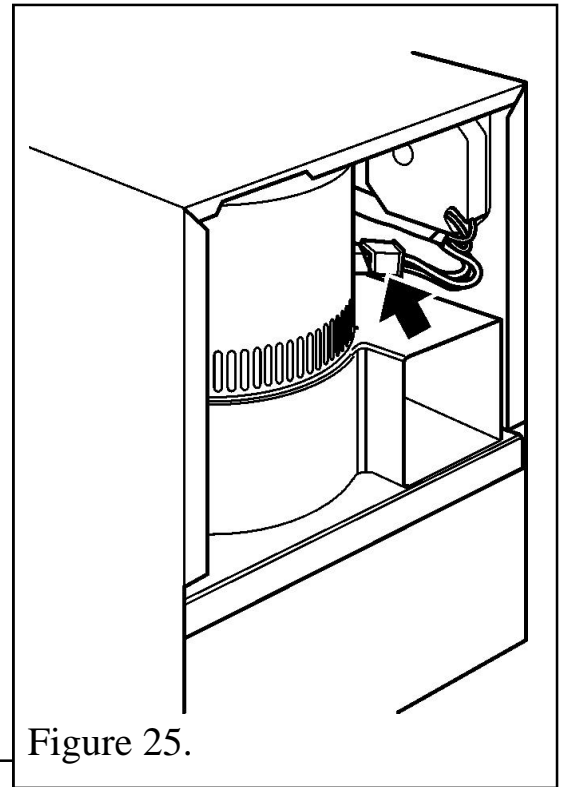

Figure 25.

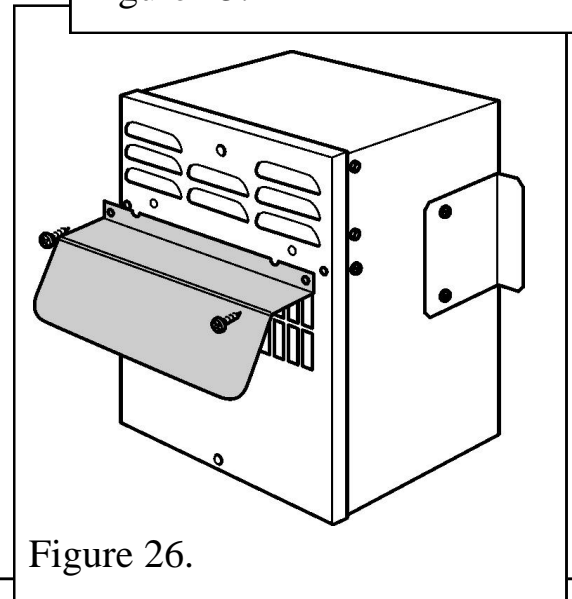

Figure 26.

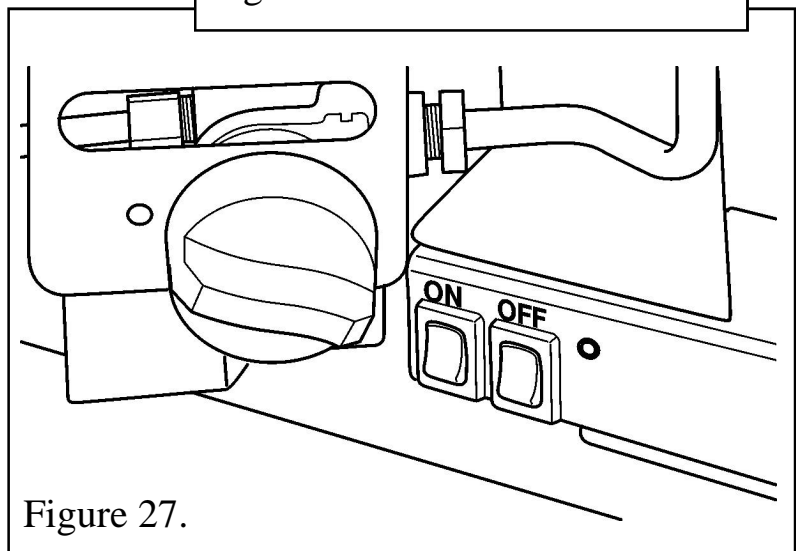

Figure 27.

INSTALLER GUIDE

- i.* Switch the fan on.
- ii.* Block off the rectangular exhaust outlet of the terminal. The system should shut down within ten seconds.
- iii.* After checking turn off the electrical supply to the appliance. If the above tests are not satisfactory, refer to the servicing section of this manual.

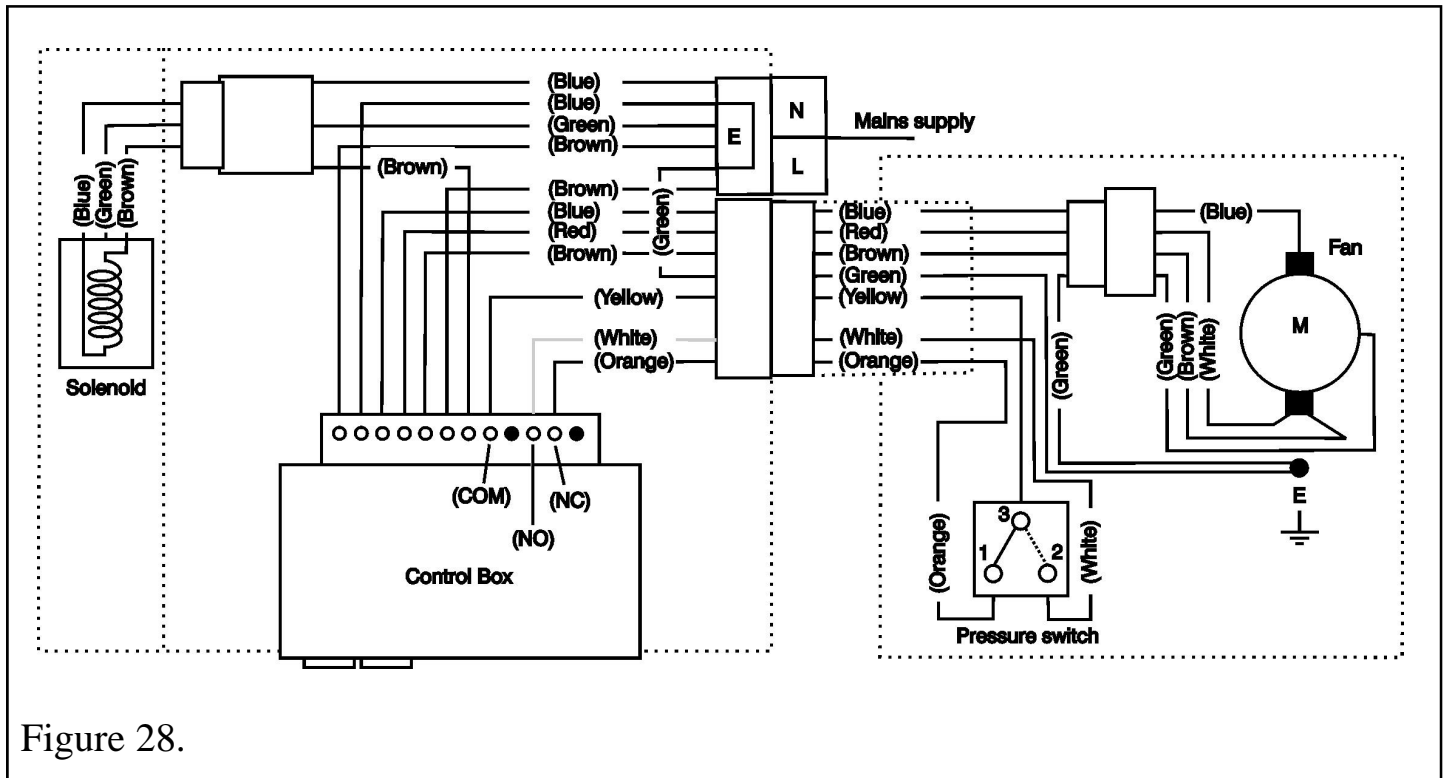

Figure 28.

8.8 Terminal guarding.

Position the terminal guard to wall, align and ensure equal clearances around fan box. Mark off the four fixing positions on wall. Remove the terminal guard and drill at the marked positions, four holes using a no. 10 drill. Insert wall plugs, reposition the terminal guard and secure to wall using four screws supplied.

9. GAS SUPPLY INSTALLATION

9.1 Gas supply connection.

1. Connect the supply line to the appliance.
2. Unless the supply pipe connection is from the left front side, the supply pipe will have to be formed to avoid various components below the burner. If a visible connection is to be made, it will be necessary to cut a small notch in the side of the fret to allow the gas pipe to pass.
3. If gas supply is to the rear of the appliance, then entry is via the large grommet, at the lower left hand side of the back face. Pierce the grommet to allow pipe entry (See figure 29).

INSTALLER GUIDE

4. Check the installation pipework for gas soundness in accordance with the current edition of BS6891.

Do not use leak detection sprays on this appliance. Sprays may affect the operation of electrical components. Keep all liquid detection fluids clear of electrical components. A long brush may be required to reach some joints.

9.2 Preliminary burner checks.

Some burner operations can be checked at this stage. Checking now will mean that less disassembly will be required if any problems are found. **A full check should still be made, however, after final installation.**

- Switch on electrical power supply to the appliance.
- If closed, open the isolating valve at the inlet 'T' connector.
- Press the "on" switch. Within a few seconds, the fan motor will start and the neon indicator will light. The neon light is an indication that the fan is in 'boost' mode.
- After a few seconds the fan motor should reduce in speed and be operating at 'normal' speed. The neon indicator will no longer be illuminated.
- Depress the control knob and turn anticlockwise partially towards the "PILOT/IGN" position until some resistance is felt. Keep depressed at this position to purge air from the system then, while keeping it depressed, turn fully to the "PILOT/IGN" position. A spark should be generated at the pilot while turning. The spark should ignite the pilot.
- When pilot ignition has been achieved, keep the control knob depressed for approximately ten seconds to allow the thermocouple probe to warm up and then release it. If the pilot does not remain alight, ensure that the air has been purged, that the pilot orifice is clear and that the thermocouple connections are sound. Replace the pilot unit if necessary (See servicing section of this manual).
- When the pilot is alight and stable, partially depress the knob and turn to "LOW". The pilot should then light the main burner at its low setting. There may be a slight delay between the pilot lighting and ignition of the gas at the main burner. This is normal and is due to the time required to fill the main burner compartment with sufficient gas for ignition.
- With the burner at "LOW", partially depress the control knob and gradually turn it anti-clockwise. The burner flames should gradually increase until the knob reaches the "HIGH" position. **When the above checks have been completed partially depress the control knob and turn to "OFF" position.**
- Press the "off" switch. The fan should stop.

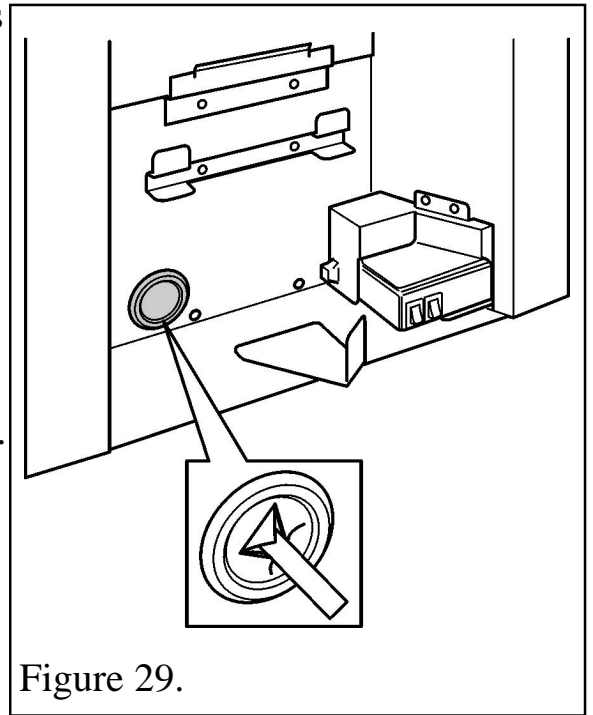

Figure 29.

INSTALLER GUIDE

- If the above checks are satisfactory, continue with the installation. If not, check the control and ignition circuitry and components as described in the servicing section of this manual.

9.3 Check inlet pressure .

The appliance is pre-set to give the correct heat input at the inlet pressure shown in section 2 of this manual. No adjustment is necessary.

1. Check the burner pressure by fitting a pressure gauge at the test point. The test point is on the inlet 'T' connector (See figure 30). Check the pressure with the fan on, the appliance alight and set to the 'HIGH' heat setting.
2. After checking, turn off the appliance. Remove the pressure gauge and replace the test point sealing screw.
3. Relight the appliance. Turn to the 'HIGH' heat setting and test around the sealing screw for gas soundness with a suitable leak detection fluid. ***Do not use leak detection sprays on this appliance. Sprays may affect the operation of electrical components. Keep all liquid detection fluids clear of electrical components.***

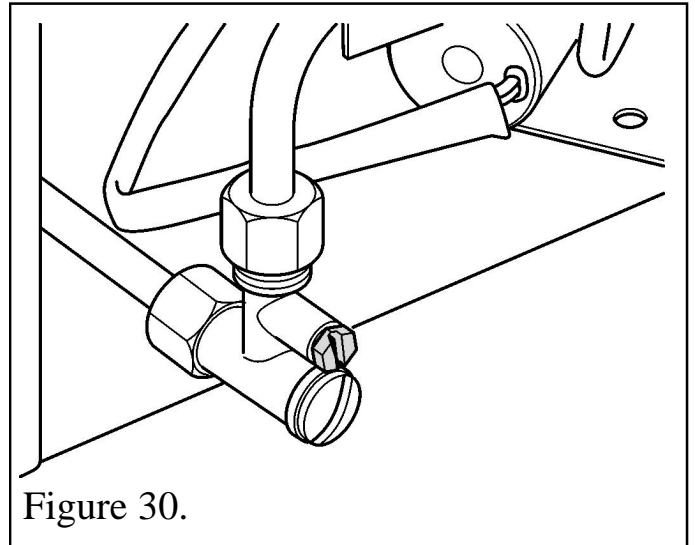

Figure 30.

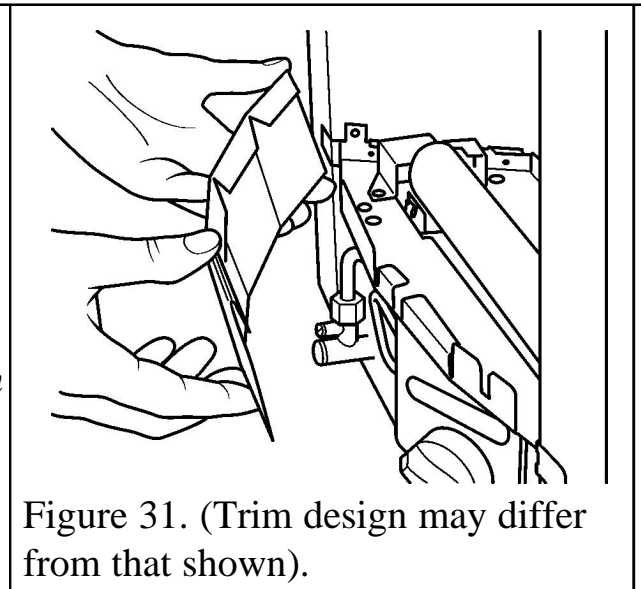

Figure 31. (Trim design may differ from that shown).

9.4 Fitting the burner tray trim.

The burner tray trim is to be fitted to all models except the 'Anthem'. On 'Chic' models the burner tray trim is part of the fascia pack. Fit the burner tray trim to the burner tray as in figure 31. The lip at the back of the trim should locate over the front edge of the burner tray.

10. FITTING THE CERAMICS

The installer and owner guide for the ceramic fuel effect is supplied with the ceramic fuel effect. It is important that the installer and owner guide for the ceramic fuel effect be placed inside or attached to this guide and handed to the customer following completion of the 'final review' section.

11. FITTING THE FASCIA AND FIREFRONT

11.1 Fitting the 'Dream' fascia.

1. Place the fascia against the fireplace front surface so that the two retaining plates at the back of the fascia are above the two upper retaining brackets at the top of the convection box.
2. Lower the fascia making sure that the rear retaining plates locate fully into the retaining brackets on the convection box (See figure 32). If the inlet pipe runs along the front of the fireplace, the bottom of the fascia will have to be swung forwards to clear the pipe while lowering the casting.
3. Align the bottom fixing holes with those in the convection box. Fix the bottom of the fascia to the convection box with two screws (See figure 33).

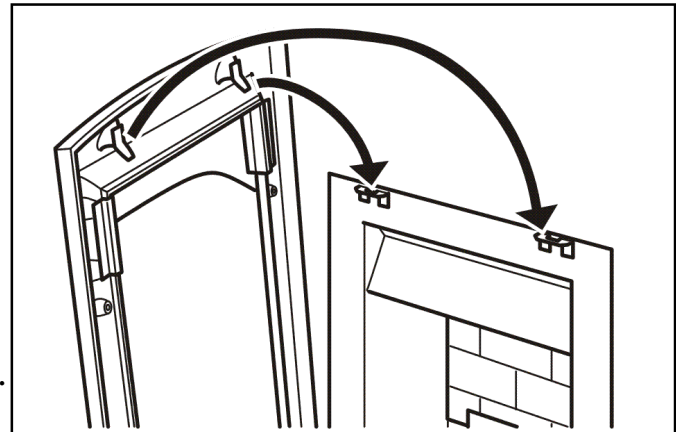

Figure 32. "Dream" fascia top location

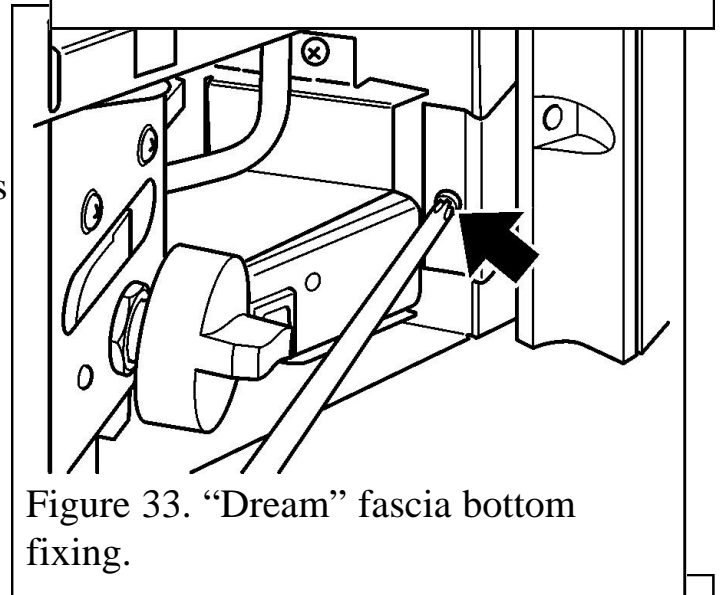

Figure 33. "Dream" fascia bottom fixing.

11.2 Fitting the 'Camden' fascia.

1. The fascia is supplied in three pieces. Carefully remove the three fascia pieces from the packaging. Remove any protective film.
2. The magnets used to locate each fascia trim should already be positioned on the rear of each trim. Each fascia trim should have two magnets. If the magnets are not fitted then locate one magnet centrally at each end of the trims.
3. Locate the side fascia trims as in figure 34.
4. Locate the top fascia trim as in figure 34.

11.3 Fitting the Anthem, 'Sonnet (Brass)' & 'Blenheim' fascia.

1. The fascia is supplied in three pieces. Remove any protective film. The two longer pieces are the left and right sides. The shorter piece is the top. The left and right hand pieces have folded edges, one of which is shorter than the other.

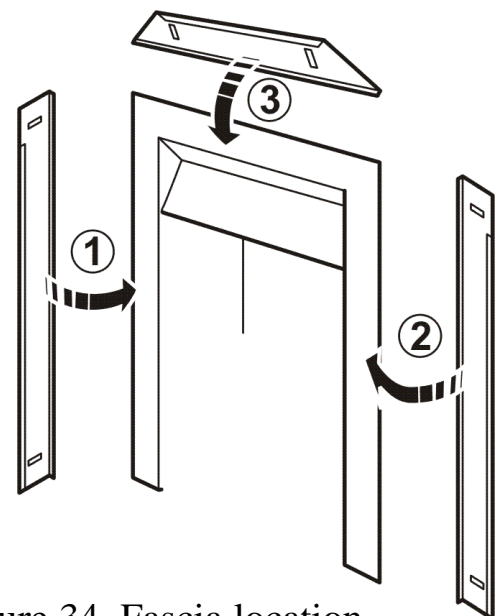

Figure 34. Fascia location

INSTALLER GUIDE

This shortened edge should be fitted at the inner top on both sides. Fit the top piece last and centralise (See figure 35)

11.4 Fitting the firefront castings on 'Blenheim', 'Dream' and 'Sonnet' models.

1. The Blenheim and Sonnet (Brass) castings have decorative brass finials that may not be fitted when supplied. Screw these into place.
2. Place the firefront casting centrally on top of the hearth in front of the fascia.
2. Place the bottom front cover casting in position.

11.5 Fitting the firefront castings on the 'Anthem' model.

1. The 'Anthem' firefront is supplied with two brackets. These brackets are to hang the firefront casting to the burner tray.
2. Remove the two M4 screws from the rear of the firefront casting (See figure 36). The top section of the casting will detach from its support leg.
3. Position the brackets as in figure 36 and secure the brackets and

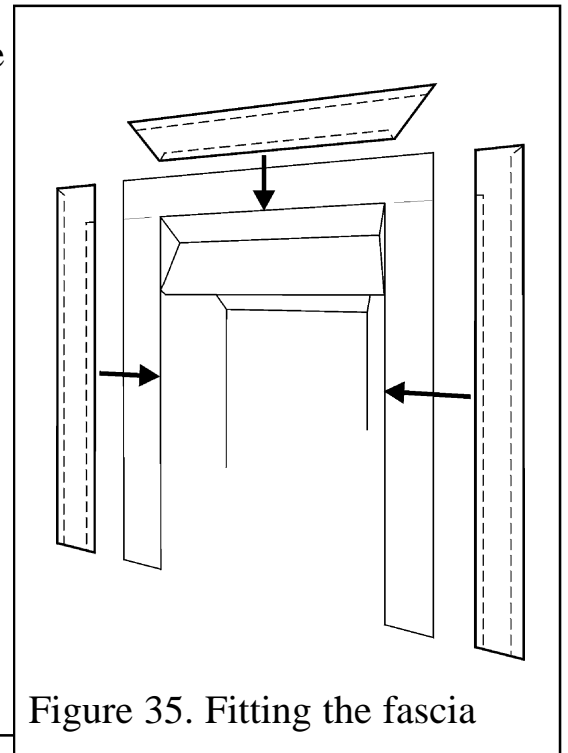

Figure 35. Fitting the fascia

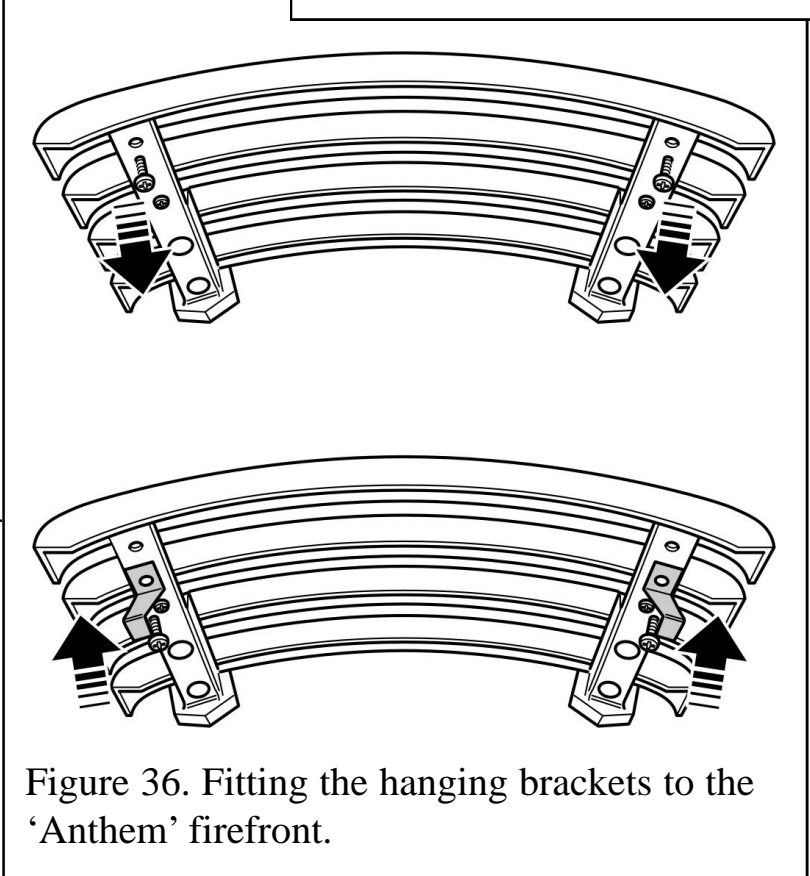

Figure 36. Fitting the hanging brackets to the 'Anthem' firefront.

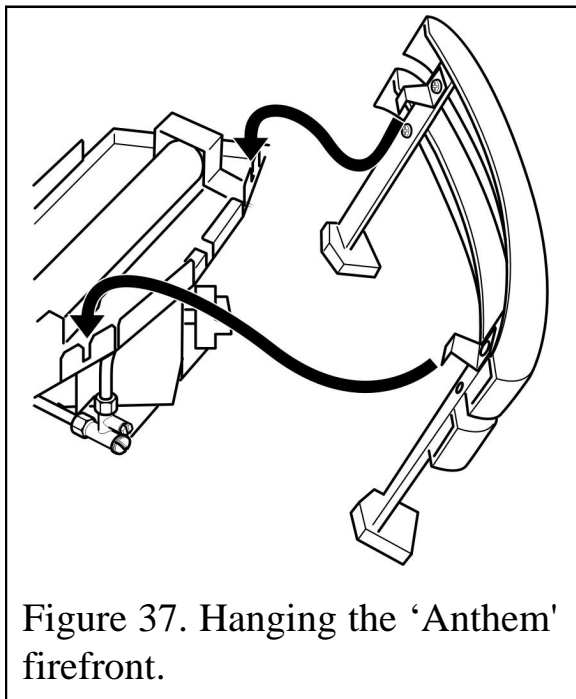

Figure 37. Hanging the 'Anthem' firefront.

INSTALLER GUIDE

casting top section in place using the two screws previously removed.

4. Hang the firefront casting onto the burner tray front (See figure 37)

5. Locate the lower firefront casting as in figure 38.

11.6 Fitting the 'Camden' firefront.

1. Place the firefront centrally on top of the hearth in front of the fascia.

11.7 Fitting the 'Chic' firefront.

1. Remove the packing from the fascia.

2. The lower fascia section (with the tubular bar across it) is held in place with magnets. Hold the sides of the lower fascia and pull gently forward to remove.

3. Fit the fascia to the appliance by locating the top to the upper hanging brackets (See figure 39), then attaching it to the body of the appliance using the two screws supplied (See figure 40).

4. Supplied in the fascia pack are two tubular trim sets. Hang one set at the top of the fascia and the other at the bottom (See figure 41).

5. The lower section of the fascia is secured with magnets. Locate it as in figure 42. The bottom of the lower section should sit on the tags as shown.

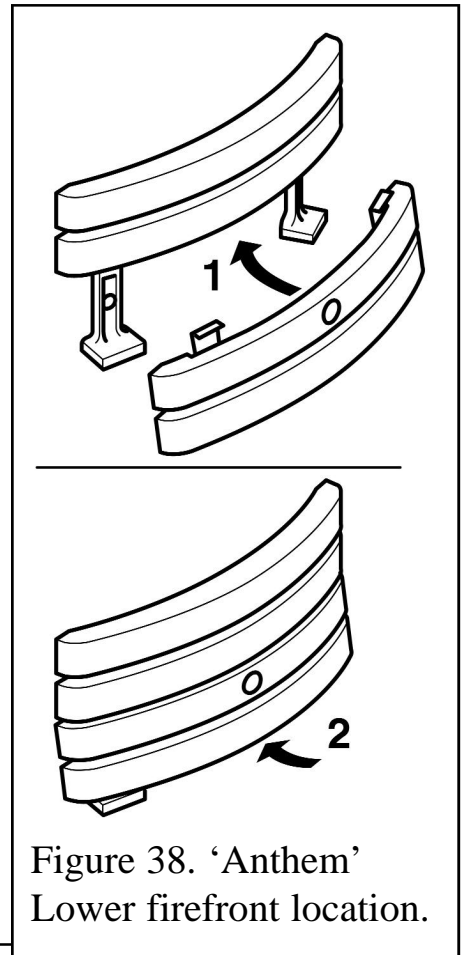

Figure 38. 'Anthem' Lower firefront location.

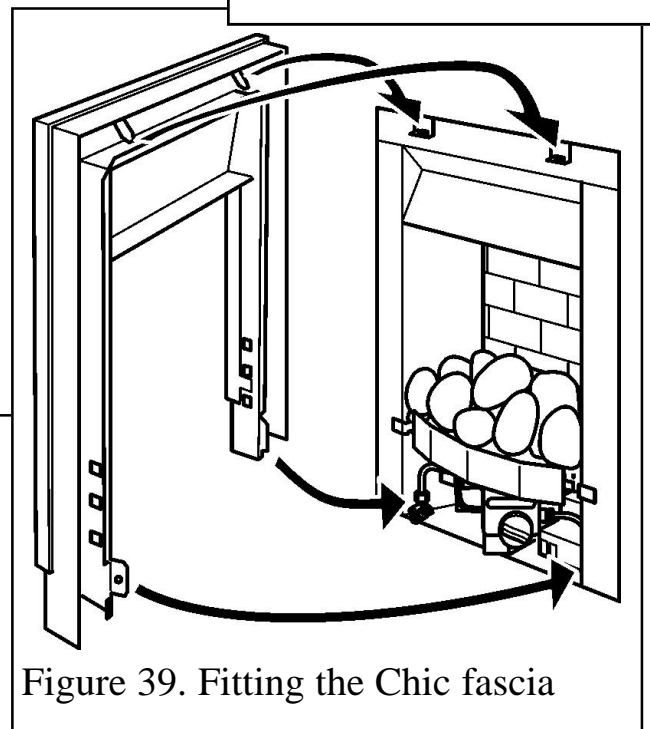

Figure 39. Fitting the Chic fascia

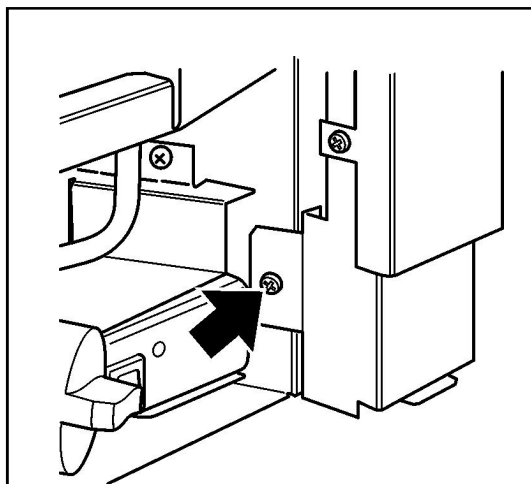
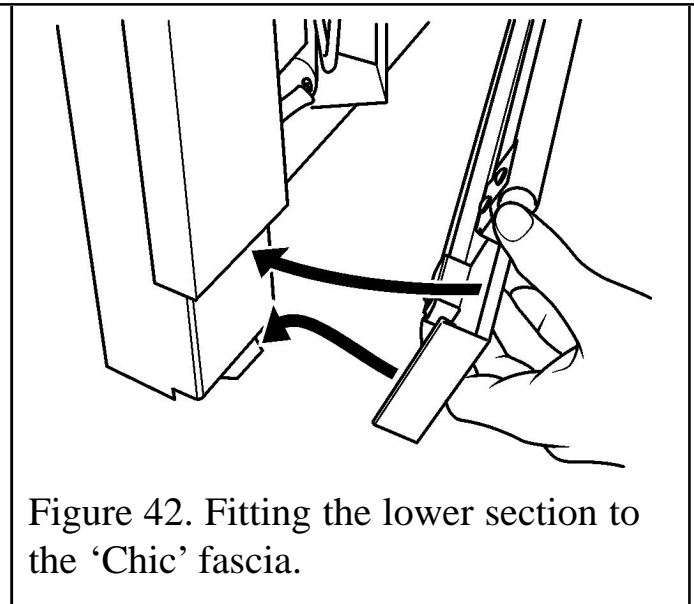
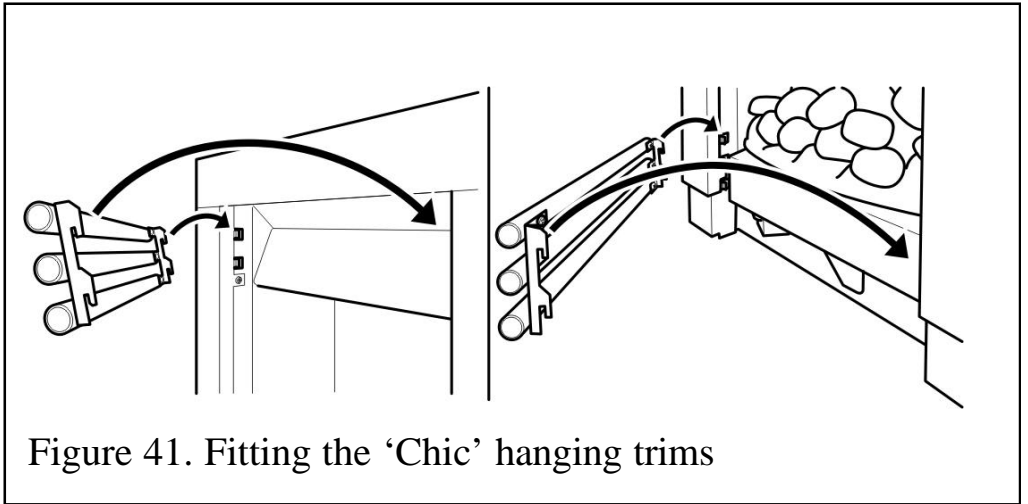

Figure 40. 'Chic' fascia securing screws.

INSTALLER GUIDE



12. CHECKS

12.1 Recheck control settings.

Now that all the ceramic fuel effect and fascia are in position, the control operation must be fully rechecked (See section 9.2).

12.2 Check for spillage.

A spillage check must be made before leaving the installed appliance with the customer. Make this check with the appliance fully installed with the ceramic fuel effects and fascia in position.

- Close all doors and windows in the room containing the appliance.
- Turn on the fan. Light the appliance and turn the control knob to "HIGH".
- Leave the appliance on for five minutes.
- Place the smoke match tube into the burner box below the hood (See figure 43).
- The installation is satisfactory if the smoke is drawn into the appliance. If the smoke

INSTALLER GUIDE

is not drawn into the appliance the fan powered extraction system is not operating correctly. ***Do not allow the appliance to be used until the fault is corrected.***

- If the above test is satisfactory, open all internal connecting doors, hatches, etc. in the room. Keep all doors and windows that open to the outside of the building closed. Recheck for spillage as above. If an extractor fan or other air circulating system is installed in the same room as the appliance or a connecting room, check that spillage does not occur with the fan operating and all doors and other openings between the fan and the appliance open.
- If the smoke is drawn into the appliance, continue with the installation. If the test is not satisfactory, ***Disconnect the appliance and seek expert advice.***
- If any other non-sealed gas appliances are installed in connecting rooms, check to ensure that there is no spillage from these appliances when the Powerflue is operating with its fan on. Check these other appliances by the procedure supplied by the manufacturer.

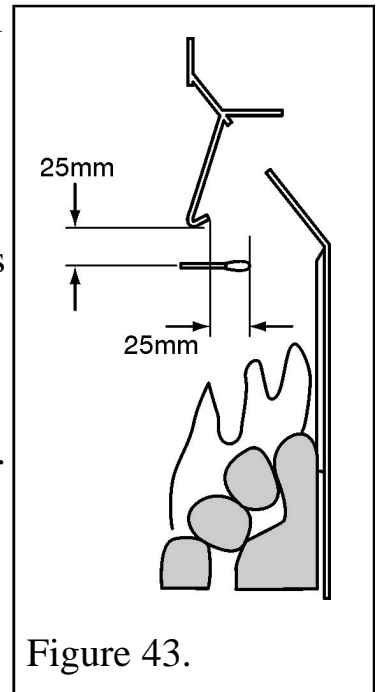

Figure 43.

12.3 Flame supervision and spillage monitoring system.

The pilot unit incorporates a system which will automatically shut off the gas supply if the pilot flame goes out or if there is insufficient oxygen due to spillage or lack of ventilation.

Check that the system operates properly as follows;

- Turn on the fan. Light the appliance and turn the control knob to “HIGH”. Leave for one minute.
- Turn back to “OFF” to extinguish the pilot. ***Note the time when the pilot goes out.*** Listen for a snap sound at the gas tap. ***Note the time when the sound is heard.*** This sound is caused by an electromagnetic valve shutting off the gas supply through the tap. The valve is located in the body of the tap. The valve should operate ***within 60 seconds of the pilot going out.*** If the valve does not operate within this time limit do not allow the appliance to be used until the fault has been corrected.

This monitoring system must not be adjusted, bypassed or put out of operation.

This monitoring system, or any of its parts, must only be exchanged using Baxi Fires Division authorised parts.

INSTALLER GUIDE

13. FINAL REVIEW

1. Visually inspect the appliance. Clean off any marks incurred during installation.

Metal Parts

- Clean the metal parts with a slightly damp lint free non-abrasive cloth and then dry.
- Do not use abrasive cleaners as these will scratch the fire surface.
- **Camden and Chic fascia** - Clean the metal parts with a slightly damp cloth and then dry. If this does not work apply a very small amount of 'baby oil' to a lint free non-abrasive cloth and wipe over the surface. Use a clean cloth to wipe off the oil.
- Carefully place the fire front castings / fire front into position.
- Attach the installer and owner guide for the ceramic fuel effect to this guide. Hand the literature pack, this guide and the smoke match tube to the customer.
- Advise the customer how to operate the appliance.
- Explain to the customer that the appliance has a flame failure & spillage monitoring system. Point out the explanation of this system shown in the owner guide under "Operating the Fire". Advise that if the fire goes out for any reason, wait at least three minutes before relighting.
- Stress that if the monitoring system repeatedly shuts off the fire, the appliance should be switched off and a specialist should be consulted.
- Advise the customer that the castings, fascia, firebox and ceramic pieces can be cleaned as described in the owner guide and that the ceramic fuel effect pieces must be replaced as described in the installer and owner guide supplied with the ceramic fuel effect, which you should leave with this guide.
- *Stress that no extra ceramic fuel effect pieces must be added over and above those supplied with the appliance and that any replacements must only be the authorised spares. Warn that ignoring this advice could cause incomplete clearance of the products of combustion with consequent health hazards.*
- Recommend that the appliance should be serviced by a competent person at least annually.

14. SERVICING PARTS AND REPLACEMENT

- **Always turn off the gas and isolate the electric supply before commencing any servicing and make sure that the appliance is completely cold. (The inlet 'T' connector for this appliance incorporates an isolating valve).**
- **This product uses fuel effect pieces and a burner compartment rear wall containing Refractory Ceramic Fibres (RCF), which are man-made vitreous silicate fibres. Excessive exposure to these materials may cause irritation to eyes, skin and respiratory tract. Consequently, it is important to take care when handling these articles to ensure that the release of dust is kept to a minimum. To**

INSTALLER GUIDE

ensure that the release of fibres from these RCF articles is kept to a minimum, during installation and servicing we recommend that you use a HEPA filtered vacuum to remove any dust and soot accumulated in and around the fire before and after working on the fire. When replacing these articles we recommend that the replaced items are not broken up, but are sealed within a heavy duty polythene bag, clearly labelled as RCF waste. This is not classified as “hazardous waste” and may be disposed of at a tipping site licensed for the disposal of industrial waste. Protective clothing is not required when handling these articles, but we recommend you follow the normal hygiene rules of not smoking, eating or drinking in the work area and always wash your hands before eating or drinking.

- Check that the appliance is clean and that soot or debris is not blocking the gaps between the ceramic fuel effect pieces causing an imperfect flame.
- Check that soot or debris is not impairing the electrode spark or pilot burner.
- Check that soot or debris is not blocking any of the slots / holes in the main burner.
- Remove any lint from the components.
- After servicing, make sure that the ceramic fuel effect pieces are replaced correctly as described in the installer and owner guide supplied with the ceramic fuel effect. The installer and owner guide supplied with the ceramic fuel effect should have been placed inside or attached to this guide by the installer.
- *Always test for gas soundness and spillage after servicing the appliance and check operation of all controls. (Do not use leak detection sprays on this appliance. Sprays may affect the operation of electrical components. Keep all liquid detection fluids clear of electrical components).*

14.1 Checking the aeration setting of the burner.

1. The aeration shutter is factory set. It is important to ensure that the aeration setting is correct for the ceramic fuel effect used. Check the aeration shutter setting (See figure 44).

2. To adjust the aeration setting to suit the fuel effect used, loosen the two aeration shutter screws, slide the aeration shutter to the desired position and tighten the fixing screws.

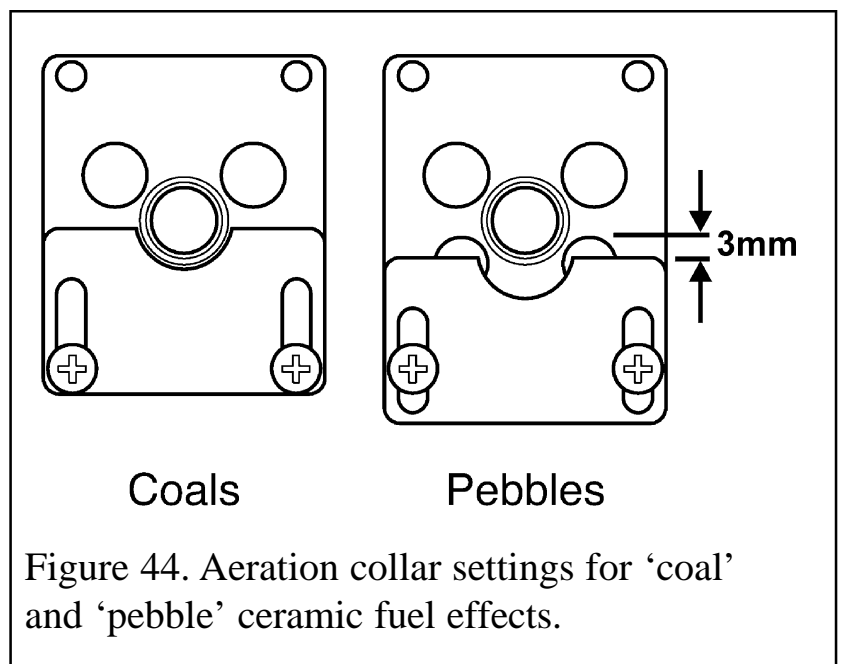

INSTALLER GUIDE

14.2 To remove the complete burner module.

1. Remove the fire front castings / fire front.
2. Remove the ceramic fuel effect and place carefully aside. The ceramic fuel effect pieces can discolour decorative surfaces. It is therefore advisable to protect decorative surfaces.
3. Support the inlet 'T' connector to avoid straining the pipework and disconnect the appliance.
4. Remove the two burner securing screws (See figure 45). It may be necessary to remove the fascia.
5. The solenoid valve leads are connected to the control box under the burner module. Carefully lift the burner unit out from the hotbox and place immediately in front of the hotbox. Do not attempt to lift the burner module away from the front of the firebox as this may damage the solenoid leads.
6. Disconnect the solenoid leads from the control box (See figure 46).

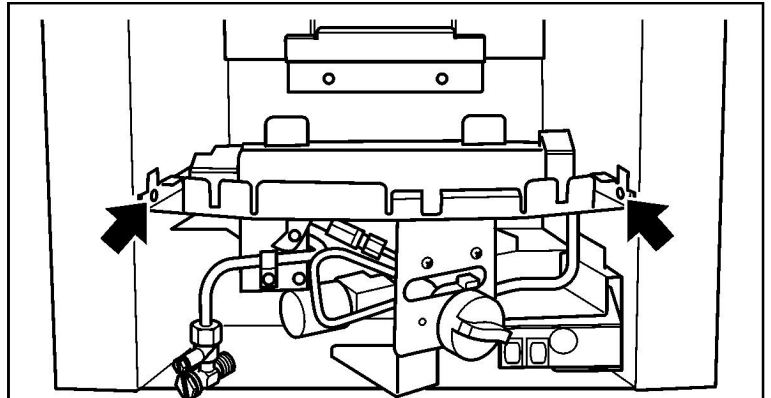

Figure 45. Burner securing screws

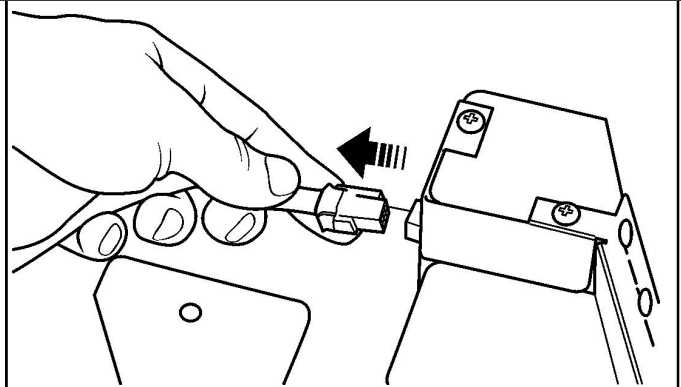

Figure 46. Removing the solenoid leads from the control box.

14.3 To remove the pilot unit.

1. Remove the complete burner module (See section 14.2).
2. Disconnect the electrode lead from underneath the electrode. To do this firmly hold the electrode lead and gentle pull the lead clear of the electrode.
3. Remove the thermocouple 'push on' connector to the gas valve. To do this, firmly hold the thermocouple connector and gently pull it clear of the gas valve (See figure 47). **Never hold the thermocouple wire when pulling.**
4. Detach the pilot pipe from the pilot unit.
5. Remove the two screws securing the pilot unit to the burner (See figure 48).
6. Remove the pilot unit and place it aside.
7. Refit in the reverse order. Make sure no leads are trapped.

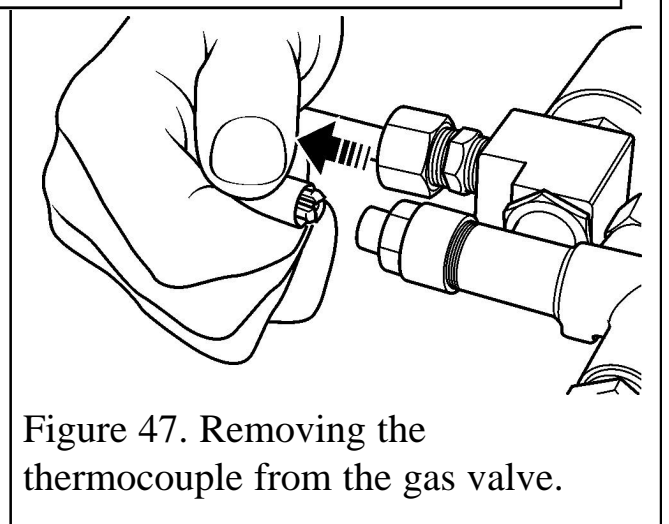

Figure 47. Removing the thermocouple from the gas valve.

Note 1. The pilot unit must be replaced as a whole assembly. Its individual components

INSTALLER GUIDE

are not separately replaceable.

14.4 To remove the burner from the burner module.

(See figure 49).

1. Remove the complete burner module (See section 14.2).
2. Support the elbow injector and unscrew the injector nut.
3. Remove the two screws from the burner clamping plate (See figure 49)
4. Lift the right hand side of the burner, slide it to the right and lift clear
5. Refit in reverse order.

14.5 To remove the main burner injector.

(See figure 50).

1. Remove the burner as in point 1-4 of section 14.3.
2. Remove the burner clamping screw (See figure 50)
3. Unscrew the injector from the burner.
4. Refit in the reverse order.

14.6 To remove the gas tap/F.S.D & solenoid assembly.

1. Remove the complete burner module as in section 14.2
2. Disconnect the electrode lead from underneath the electrode. To do this firmly hold the electrode lead and gently pull the lead clear of the electrode.
3. Remove the thermocouple 'push on' connector to the gas valve. To do this, firmly hold the thermocouple connector and gently pull it clear of the gas valve (See figure 47). **Never hold the thermocouple wire when pulling.**
4. Disconnect the inlet pipe at the solenoid junction.
5. Disconnect the main burner pipe at the gas valve.
6. Disconnect the pilot pipe at the gas valve.
7. Pull off the control knob.
8. Remove the gas tap fixing nut.

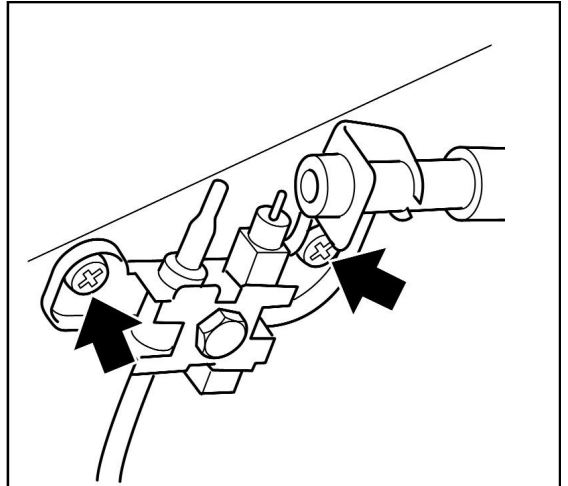

Figure 48. Pilot unit removal

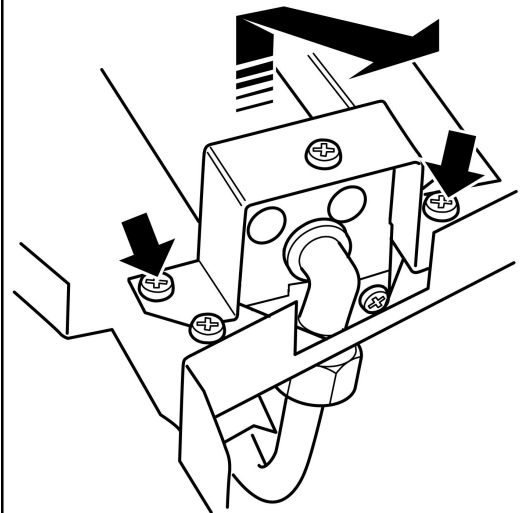

Figure 49. Removal of burner

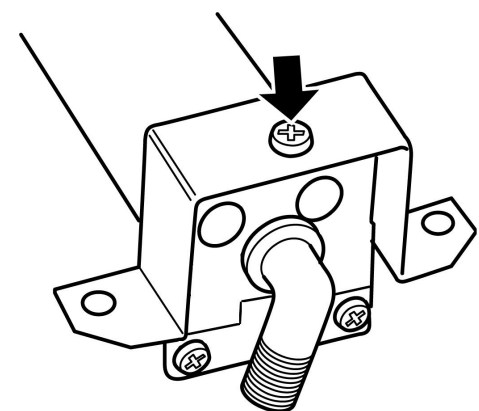

Figure 50. Main burner injector removal

INSTALLER GUIDE

9. Pull the gas valve and solenoid unit clear.

10. To separate the gas valve from the solenoid, detach the solenoid unit at the gas valve end.

11. Replace in the reverse order.

14.7 To remove the piezo generator.

1. Remove the gas valve and solenoid unit as described in section 14.6.

2. Make sure that the gas valve is in the 'OFF' position.

3. Remove the circlip holding the piezo unit to the tap.

4. Remove the piezo unit.

5. Replace in the reverse order.

14.8 To gain access to the electrical control components.

1. Remove the complete burner module as in section 14.2.

2. Detach the control unit from the hotbox by removing two screws (See figure 51). Carefully withdraw the unit.

3. Detach the fan wiring loom connection (See figure 52).

4. The control unit can be pulled forward as far as the slack in the mains lead will allow. **Do not stress the mains lead.**

5. Unscrew the two screws on top of the control box housing (See figure 53)

6. To remove the control box from its housing hold it firmly and slowly slide it clear. **Be careful not to stress the wiring**

7. When replacing the unit make sure that all the leads are correctly and firmly connected (See wiring diagram figure 28), and that no leads are trapped.

14.9 To remove the mains lead connector.

1. Remove the electrical control components as in points 1-6 section 14.8.

2. Make note of the wiring locations to the mains lead connector. Disconnect the earth (green), live (brown) and neutral (blue) leads from the mains lead connector. **Always**

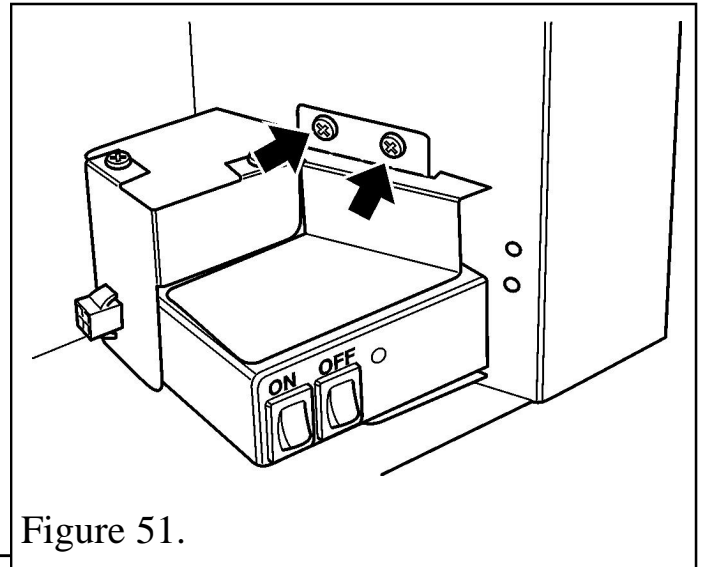

Figure 51.

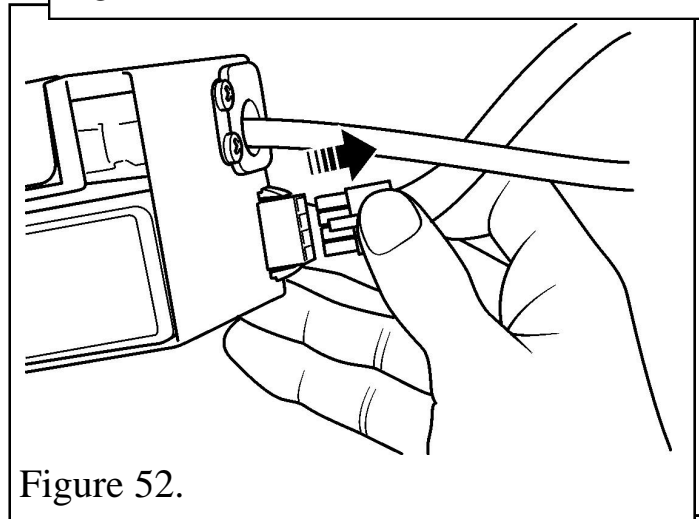

Figure 52.

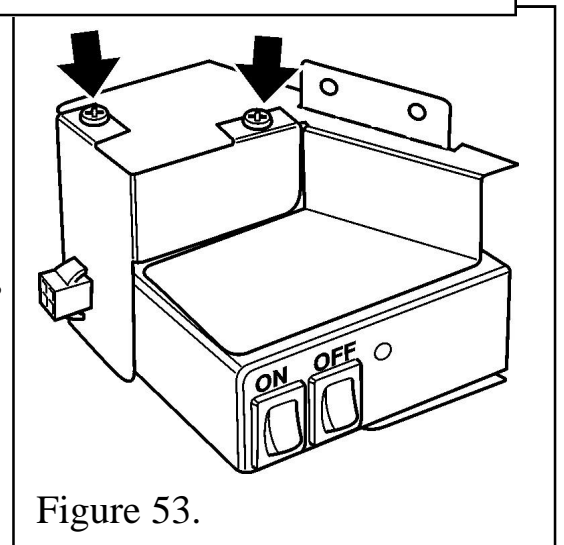

Figure 53.

INSTALLER GUIDE

hold the wire terminals, never pull on the wires.

3. Unscrew the two mains lead connector screws located on the outer housing (See figure 54).

4. The mains lead connector has two tags that hold it in place. There is a slot in the top of the control box housing for access to the top tag (See figure 54). Press the top and bottom tags and slide the mains lead connector clear of the control box housing.

5. Replace in reverse order. Make sure that all the leads are correctly and firmly connected (See wiring diagram figure 28) and that no leads are trapped.

14.10 To remove the fan.

1. Where fitted remove the terminal guard basket, and then the weather shield and front cover of the fan box (2 screws).

2. Disconnect the wiring loom connector at the fan motor casing.

3. Withdraw the fan unit from the fan box taking care not to snag or damage the wiring loom (See figure 55).

4. Replace in reverse order.

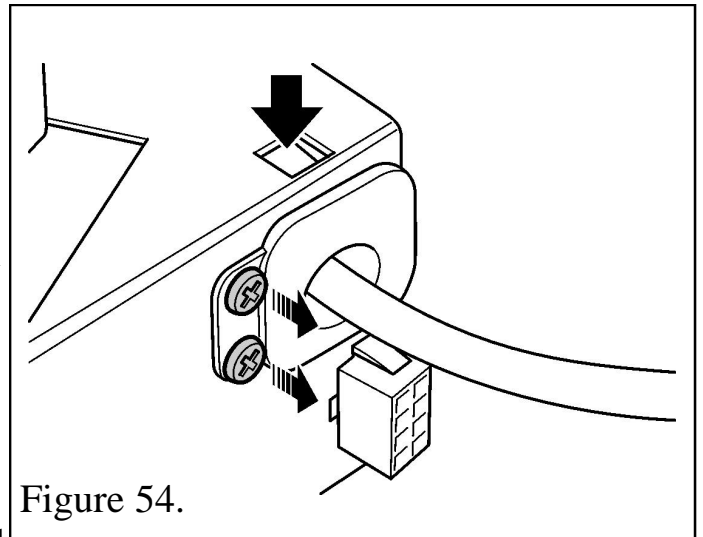

Figure 54.

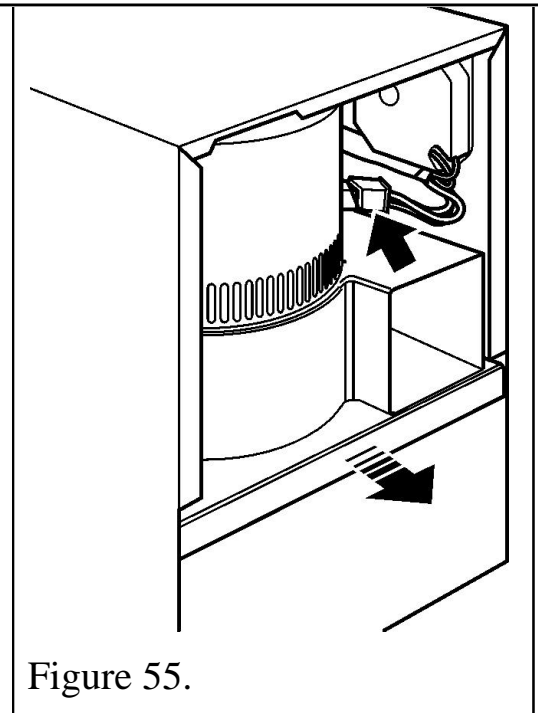

Figure 55.

INSTALLER GUIDE

14.11 To remove the pressure switch.

1. Remove the fan as in points 1-3 of section 14.10.
2. Disconnect the wiring loom to pressure switch connector.
3. Remove the two pressure switch fixing screws, and carefully prise free the two rubber sensing tubes whilst withdrawing the pressure switch from the fan box. *Note : Ensure that the tube ends secured to the metal sensing pipes at the back of the box are not disturbed.*
4. Replace in reverse order.

When replacing...

- Ensure that the vacuum tubes are connected to the correct sensing points. The positive sensing point (marked ⊕ on the switch) runs to the metal sensing pipe positioned nearest to the side of the fan box. *Note: When fitted correctly, both leads will run neatly, but if incorrectly fitted, they will twist across each other.*
- Ensure the electrical connector is correctly and firmly connected.

14.12 Pressure switch strip down.

1. Remove the cover from the pressure switch to gain access (See figure 56).
2. Disconnect the three leads, yellow, orange and white.
3. Replace in reverse order. Ensure that all three leads are firmly connected (See figure 57).

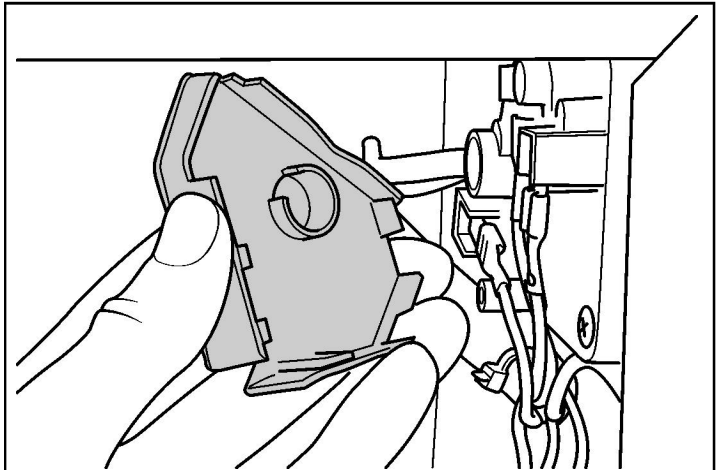

Figure 56.

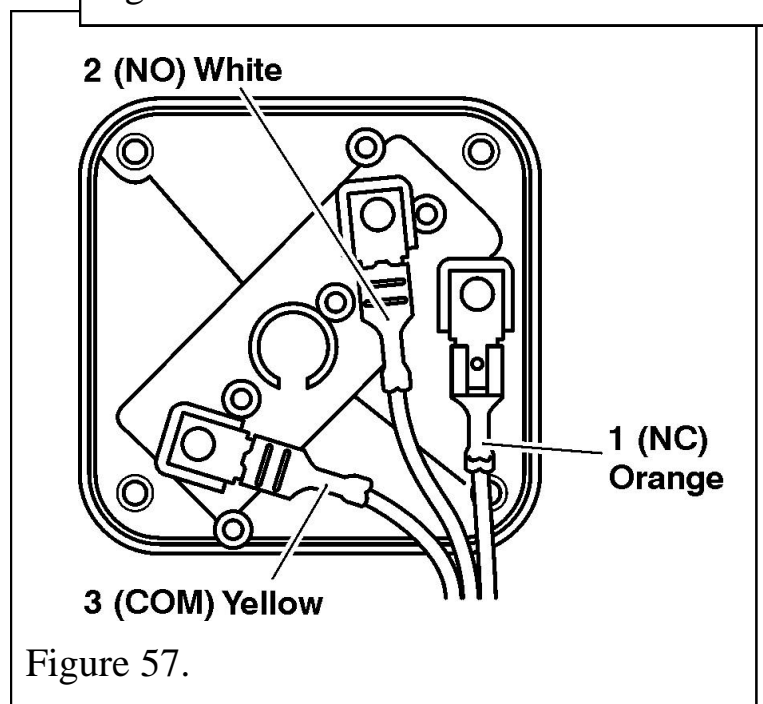

Figure 57.