

# BAXI FIRES DIVISION

## OWNER GUIDE

Model 661  
POWER FLUE INSET GAS FIRE

Fitted with  
Anthem,  
Blenheim,  
Camden,  
Chic,  
Dream or  
Sonnet fascia



(GC No. 32-810-15)

**THIS APPLIANCE IS FOR USE WITH NATURAL GAS (G20).  
WHEN CONVERTED USING CONVERSION KIT NO. 0595221 THIS  
APPLIANCE IS FOR USE WITH PROPANE GAS (G31).  
THIS APPLIANCE IS SUITABLE ONLY FOR INSTALLATION IN THE UNITED  
KINGDOM (GB) AND THE REPUBLIC OF IRELAND (IE).**

We trust that this guide gives sufficient details to enable this appliance to be operated and maintained satisfactorily. However, if further information is required, our **Baxi Fires Division Technical Helpline** will be pleased to help.  
Telephone **08706 061 065** (National call rates apply in the United Kingdom).  
In the Republic of Ireland telephone **0044 8706 061 065**.

This guide is intended to help you care for your gas fire. Please read thoroughly before using and keep for future reference.

# BAXI ● VALOR ● WONDERFIRE

**This guide to be left with the owner**

# OWNER GUIDE

## **Safety First.**

Baxi Fires Division fires are CE Approved and designed to meet the appropriate British Standards and Safety Marks.



## **Quality and Excellence.**

At the heart of every Baxi Fires Division fire.

All Baxi Fires Division fires are manufactured to the highest standards of quality and excellence and are manufactured under a BS EN ISO 9001 quality system accepted by the British Standards Institute.



## **The Highest Standards**

Baxi Fires Division is a member of the Society of British Gas Industries which works to ensure high standards of safety, quality and performance.



## **Careful Installation**

Baxi Fires Division is a CORGI registered company. All our gas fires must be installed by a competent CORGI Registered Installer in accordance with our Installer Guide and should not be fitted directly on to a carpet or floor of combustible material.

# B A X I F I R E S D I V I S I O N

Baxi Fires Division, Erdington, Birmingham B24 9QP

[www.firesandstoves.co.uk](http://www.firesandstoves.co.uk)

Because our policy is one of constant development and improvement, details may vary slightly from those given in this publication

# OWNER GUIDE

## LIST OF CONTENTS

<u>Section</u>	<u>Page</u>
<b>SAFETY</b>	<b>4</b>
<b>GAS CONSUMPTION</b>	<b>5</b>
<b>APPLIANCE DIMENSIONS</b>	<b>6</b>
<b>OPERATING YOUR FIRE</b>	<b>7</b>
How to light your fire.	7
Lighting with a taper.	7
How to turn your fire off.	8
The flame sensing and flue blockage safety system.	8
<b>CLEANING YOUR FIRE</b>	<b>9</b>
Metal parts.	9
Ceramic fuel effect and burner compartment rear wall.	9
Burner.	9
Flue terminal.	9
Ventilation.	10
<b>CERAMIC FUEL EFFECT REFITTING</b>	<b>10</b>
<b>MAINTENANCE</b>	<b>10</b>
Regular maintenance.	10
Mains cable.	10
Servicing.	11
<b>USEFUL TELEPHONE NUMBERS</b>	<b>11</b>

---

This gas fire is designed to meet the most stringent quality, performance and safety requirements to provide you with many years' trouble-free service.

This guide aims to improve your understanding and appreciation of your gas fire by providing simple and informative instructions to ensure that you benefit from the excellent performance and features it has to offer.

**IMPORTANT :**  
**THIS APPLIANCE MUST BE EARTHED**

# OWNER GUIDE

## SAFETY

### IF YOU SMELL GAS

**DON'T SMOKE.**

**EXTINGUISH ALL NAKED FLAMES.**

**DON'T TURN ELECTRICAL SWITCHES ON OR OFF.**

**TURN OFF THE GAS SUPPLY AT THE METER.**

**OPEN DOORS AND WINDOWS TO GET RID OF THE GAS.**

**IMMEDIATELY CALL THE GAS EMERGENCY SERVICE – SEE YOUR LOCAL TELEPHONE DIRECTORY.**

**Do** have the fire installed by a competent person. In the United Kingdom, installation must be in accordance with the latest edition of the Gas Safety (installation & use) Regulations. In the Republic of Ireland, installation must be in accordance with all national and local regulations in force.

**Do** have the fire installed in accordance with the installer guide.

**Do** provide a minimum clearance of 700mm from the firebox base to any shelf made of wood or other combustible material where the shelf is not more than 150mm deep. For a shelf deeper than 150mm, add 12.5mm to the clearance for every 25mm of additional shelf depth (See graph1).

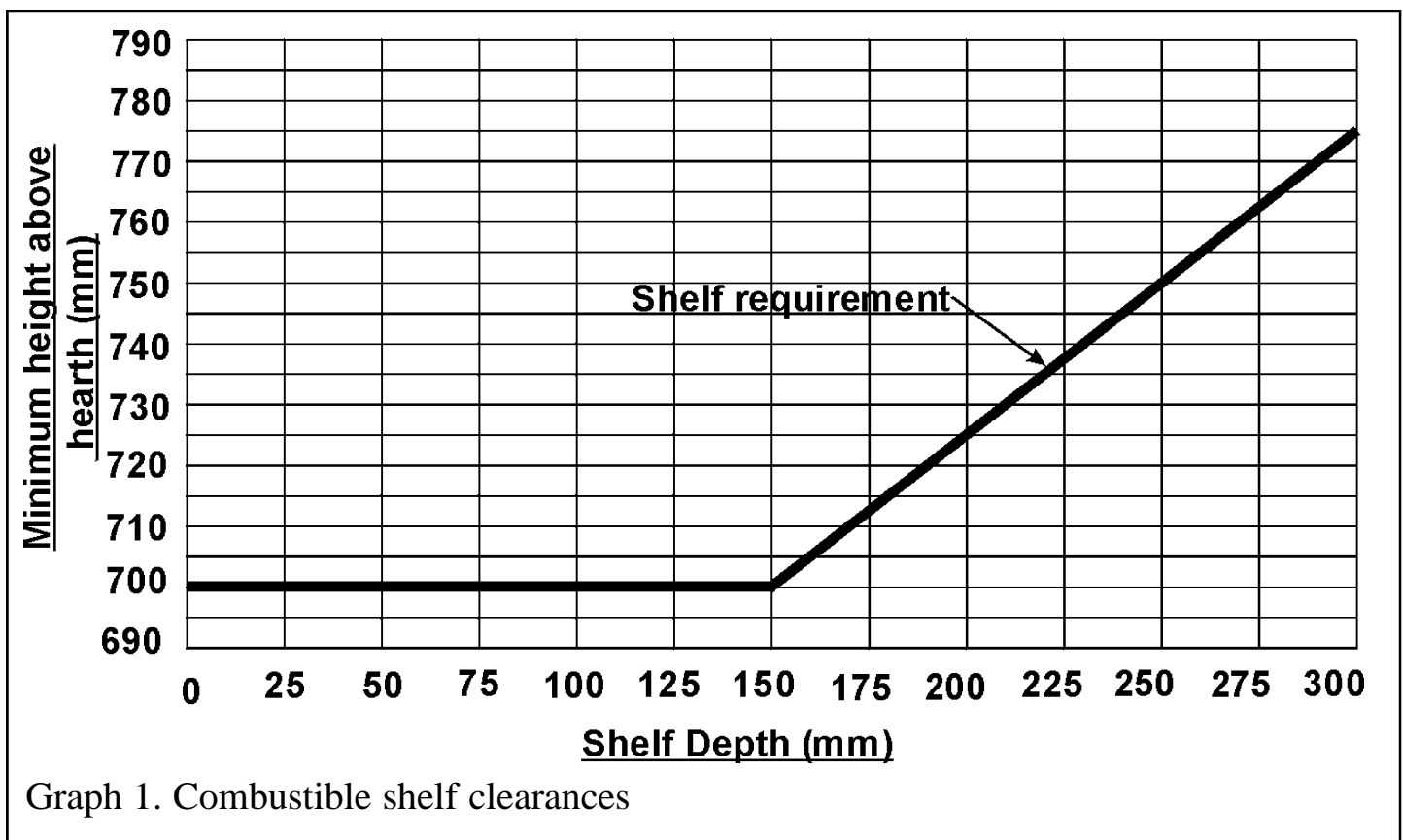

**Do** Make sure that any combustible wall finish or cladding is removed from the area within the fascia of the fire.

# OWNER GUIDE

**Do** Switch the fire and fan off and allow to cool before attempting to clean, service, etc. This appliance retains heat for some time after it has been switched off

**Do** always use a fireguard complying with BS 8423 for the protection of young children, the elderly or infirm.

**Do** wait three minutes before attempting to relight if the fire is switched off or the flames are extinguished for any reason. (Your fire is fitted with a safety device that will automatically shut off the gas supply to the fire, if for any reason, the flame goes out)

**Do** get advice about the suitability of any wall covering near your fire. Soft wall coverings (e.g. embossed vinyl, etc.) which have a raised pattern are easily affected by heat. They may, therefore, scorch or become discoloured when close to a heating appliance. Please bear this in mind whenever you are considering redecorating.

**Do** provide a minimum side clearance as detailed in figure 1. Please bear this in mind if ever you are altering the room.

**Don't** hang clothing, towels or any other fabrics over the fire.

**Don't** put more ceramic fuel effect pieces on the fire than the number stated in the installer and owner guide supplied with the ceramic fuel effect. This should have been attached to or placed inside this guide by the installer. Also, don't use any ceramic fuel effect pieces other than those authorised for this fire. Incorrect combustion and subsequent health hazard could result.

**Don't** put paper or other materials onto your fire.

**Don't** use the fire with damaged base ceramics.

**Don't** place any combustible material (rugs, carpet, plastic tiles, etc.) on the hearth

**Don't** attempt to clean or service the fire until it has been switched off and allowed to cool completely.

## GAS CONSUMPTION

### Model 661

Has a maximum natural gas input of 6.0kW (Gross)

Has a maximum natural gas output of 3.1kW

Has a minimum natural gas input of 2.3kW (Gross)

Has a minimum natural gas output of 1.1kW

### Model 661 when converted using kit number 0595221

Has a maximum propane gas input of 6.1kW (Gross)

Has a maximum propane gas output of 3.15kW

Has a minimum propane gas input of 3.8kW (Gross)

Has a minimum propane gas output of 1.8kW

# OWNER GUIDE

## APPLIANCE DIMENSIONS

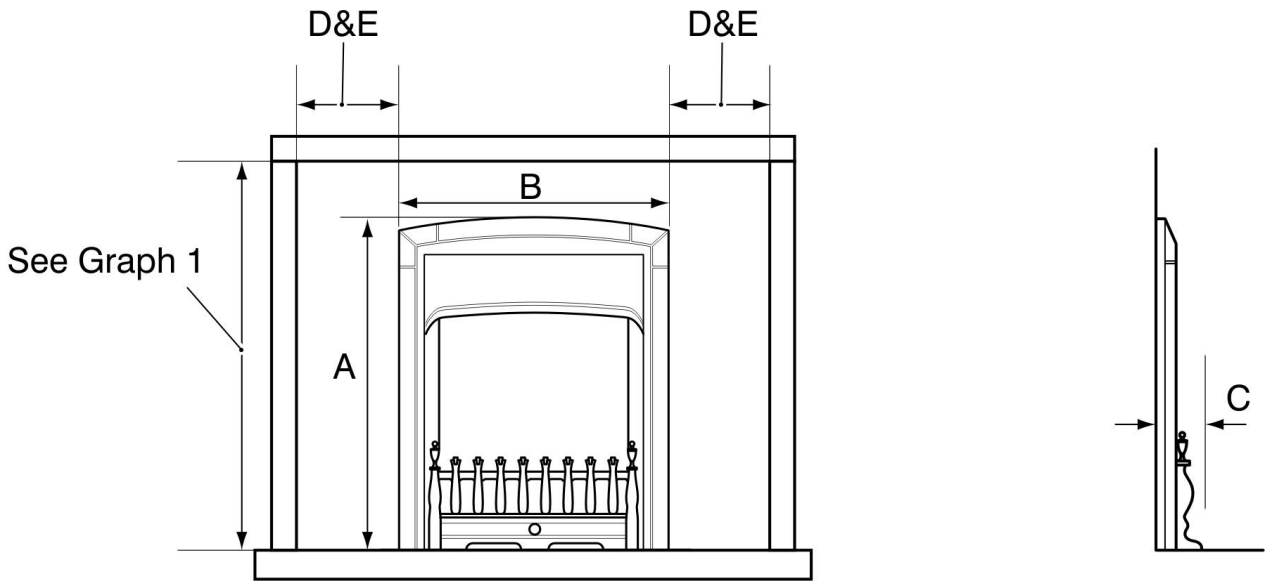

Key	Description	Model					
		Dream	Sonnet	Anthem	Camden	Blenheim	Chic
A	Appliance height (mm)	636	585	585	585	585	600
B	Appliance width (mm)	518	450	450	450	450	467
C	Appliance depth into room (mm)	94	65	71	75	65	57
D	Minimum <b>mandatory</b> clearance to <b>combustible</b> surfaces projecting beyond the front of appliance (mm).	100	100	100	100	100	100
E	<b>Recommended</b> clearance to <b>non-combustible</b> surfaces for access purposes (mm).	50	50	50	50	50	50

Figure 1. Appliance dimensions and clearances (Fascia may differ from that shown)

# OWNER GUIDE

## OPERATING YOUR FIRE

### *PLEASE NOTE*

When operating your fire for the first time, some vapours may be given off which may cause a slight odour and could possibly set off any smoke alarms in the immediate vicinity. These vapours are quite normal with new appliances. They are totally harmless and will disappear after a few hours use.

### **How to light your fire.**

- The controls are shown in figure 2.
- Check that the main isolating switch is on.
- Remove the fire front cover / fire front. The controls are behind this cover.
- Press the "ON" switch. Within a few seconds, the fan motor should start and a small light will appear on the control box next to the switches. After a few seconds the light will go out.
- Depress the control knob and turn partially to the "PILOT/IGN" position until you feel some resistance.
- Keep the knob depressed at this position for a few seconds to allow gas to flow to the pilot.
- While keeping the knob depressed, turn to the "PILOT/IGN" position. While turning, a spark should light the pilot. The pilot flame can be seen through the ceramic fuel effect at the front left side.
- Keep the knob depressed at the "PILOT/IGN" position for a further ten seconds then release it. The pilot flame should stay alight.
- Slightly depress the knob and turn it to "LOW". Release the knob. Within a few seconds the main burner should light at its low setting.
- Slightly depress the knob and gradually turn it towards "HIGH" until the burner is at your desired setting. The burner flames will gradually increase until the knob is at the "HIGH" position.

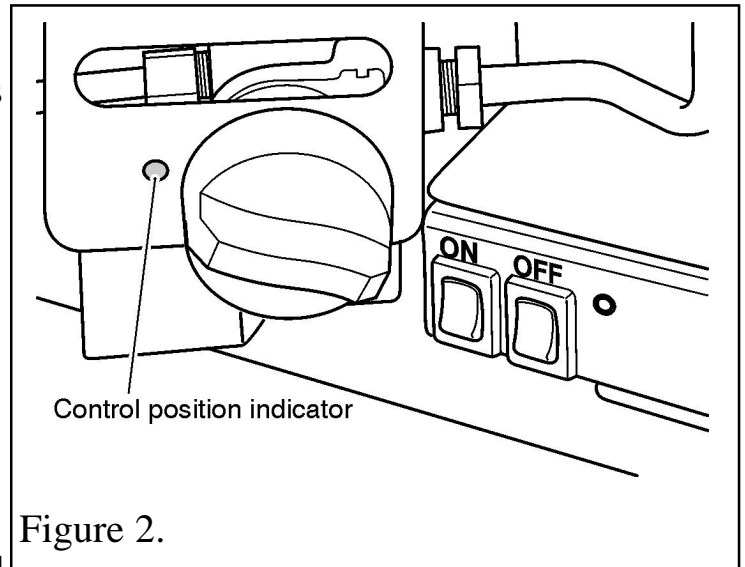

Figure 2.

### **Lighting with a taper.**

- If the spark ignition fails, the fire can be lit manually by inserting a lighted taper through the ceramic fuel effect at the front left side (as shown in figure 3) and depressing the control knob at the "PILOT/IGN" position. Ensure that the fan is on. Note: If the fire goes out while setting the control, repeat the full lighting procedure. If

# OWNER GUIDE

the fire repeatedly goes out, have the fire serviced.

## How to turn your fire off.

- **To turn off the main burner but leave the pilot alight** slightly depress the control knob and turn to "PILOT/IGN". Leave the fan switched on.

- **To turn the fire fully off** slightly depress the control knob and turn to "OFF". Press the "OFF" switch to turn the fan off. If the fire is not likely to be used again for a long time we suggest that the mains isolating switch for the fire is switched off.

- Wait at least three minutes after turning the fire off before relighting.
- While cooling, the ceramic fuel effect pieces may make some crackling noises. This is quite normal.

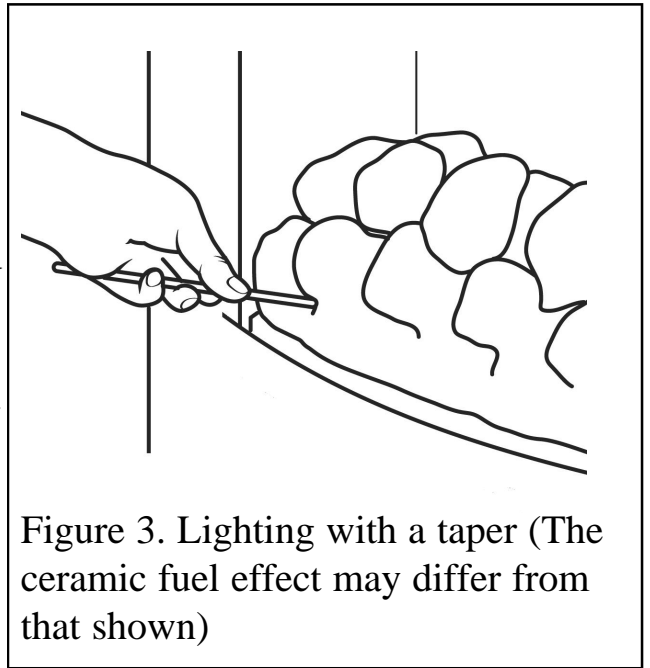

## The flame sensing and flue blockage safety system.

- For your safety, this appliance is fitted with a flue blockage safety device which will shut down the appliance in the event of abnormal flue conditions.
- This device will also shut down the appliance if the pilot flame goes out due to lack of oxygen or for any other reason.
- The system includes a probe that senses the heat from the pilot flame. If this probe is cool, the system will prevent any gas flow unless the control knob is kept depressed at the "PILOT/IGN" position.
- The system also includes an atmospheric pressure detector. This will shut off the gas supply if the fan is not working.
- If there is a blockage preventing the flow of exhaust fumes out of the flue, the fan will switch to a high boost speed to attempt to clear the blockage. If the boost speed does not clear the flue, the pressure detector will shut off the gas supply. The small light on the control box will light each time the 'boost' speed is used.
- If the flames go out, or if for any reason the fire is turned off, **always wait at least 3 minutes before attempting to relight.**
- If this device starts to shut off the gas frequently please get expert advice
- **This device is NOT a substitute for an independently mounted Carbon Monoxide detector.**



# OWNER GUIDE

## CLEANING YOUR FIRE

To maintain the high performance and quality finish of your fire, please follow these guidelines:

Before attempting to clean the fire, please remember to turn off the gas at the fire and the electricity at the isolating switch.

Wait for the appliance to cool. The fire will retain heat for some time before cleaning can begin.

### **Metal parts.**

- Clean the metal parts with a slightly damp cloth and then dry.
- Do not use abrasive cleaners, as these will scratch the fire surface.
- **Camden and Chic fascia** - Clean the metal parts with a slightly damp cloth and then dry. If this does not work apply a very small amount of 'baby oil' to a lint free non-abrasive cloth and wipe over the surface. Use a clean cloth to wipe off the oil.

### **Ceramic fuel effect and burner compartment rear wall.**

**This product uses fuel effect pieces and a burner compartment rear wall containing Refractory Ceramic Fibres (RCF), which are man-made vitreous silicate fibres. Excessive exposure to this material may cause irritation to eyes, skin and respiratory tract. Consequently, it is important to take care when handling these articles to ensure that the release of dust is kept to a minimum.**

**Light coatings of soot will usually be burnt off during the normal operation of the fire. Should any soot accumulation become excessive, the fuel effect pieces and walls should be removed from the fire for cleaning. Cleaning should be carried out in a well ventilated area or in the open air by gently brushing with the pieces held away from your face so that you avoid inhaling the dust. We do not recommend the use of a normal domestic vacuum cleaner which may blow dust back into the air. We suggest that you remove the ceramic fuel effect in the reverse order to that shown in the ceramic fuel effect installer and owner guide. This should have been left inside or attached to this guide by the installer.**

### **Burner.**

Remove any soot or other foreign matter from the burner with a dry soft brush.

Be careful not to brush any particles into the open slots.

Remove any particles from the slots with a vacuum cleaner fitted with a soft brush attachment. Do not poke wire, etc. into the slots in the burner.

### **Flue terminal.**

Keep the slots in the flue terminal on the outside wall clear of any obstructions (leaves, snow etc.)

# OWNER GUIDE

## **Ventilation.**

If any purpose made ventilation was provided for this appliance, make sure that it is always free from any obstruction.

## **CERAMIC FUEL EFFECT REFITTING**

The installer and owner guide for the ceramic fuel effect is separate from this guide. The installer may have attached it to this guide or placed it inside. It is important that the installer and owner guide for the ceramic fuel effect is followed correctly. If replacing the ceramic fuel effect, where a new guide is supplied, follow the installer and owner guide supplied with the replacement fuel effect.

Keep the replacement installer and owner guide with this owner guide for future reference.

## **MAINTENANCE**

### **Regular maintenance.**

In order to achieve and maintain high levels of personal safety and performance efficiency, it is essential that the opening at the back of the fire and the flue are kept clear of any form of obstruction. It is possible that deposits of mortar or soot could fall and accumulate causing the flue to be blocked or restricted and so preventing proper clearance of dangerous exhaust fumes.

In the United Kingdom it is the law that a landlord must have any gas appliance, flue and pipework which is situated in a tenant's premises checked for safety at least every twelve months by a competent person (In the U.K, a CORGI registered installer).

We recommend that all gas appliances and their flues, wherever situated, are checked annually.

### **Mains cable.**

If the mains cable becomes damaged it must be replaced with an authorised Baxi Fires Division replacement part. It must be replaced either by a Baxi Fires Division service engineer or a CORGI registered installer.

# OWNER GUIDE

## **Servicing.**

- In the United Kingdom servicing can be carried out either by a Baxi Fires Division service engineer or a CORGI registered installer.
- If you require your fire to be serviced, please contact **Baxi Fires Division Service** on **08706 090 081** and quote the following details;

## **IMPORTANT**

**To help us quickly help you, please try to have the following information available before you contact us:**

**Type of fire.**

**Model/Name.**

**Serial Number.**

**You will also be asked for the fault, problem or request plus your Post Code.**

- If you wish to replace any of the ceramic fuel effect pieces, spare parts are available nationwide via the ‘**interpart** stockist network’. For your local stockist consult Yellow pages under Central Heating.
- **When fitting replacement parts it is important that only approved parts are used for maximum safety.**

## USEFUL TELEPHONE NUMBERS

General advice about gas and your gas fire:

**BAXI FIRES DIVISION TECHNICAL HELPLINE      08706 061 065.**

To report faults or arrange for your fire to be serviced:

**BAXI FIRES DIVISION SERVICE      08706 090 081.**

For sales or product information:

**BAXI FIRES DIVISION SALES      08706 061 067.**

To order spares

**Spare parts are available nationwide via the ‘interpart stockist network’. For your local stockist consult Yellow pages under ‘Central Heating’.**

CALLERS IN THE REPUBLIC OF IRELAND

Call    **0044 8706 061 065**