

# BAXI FIRES DIVISION

## OWNER GUIDE

Model 750

INSET LIVE FUEL EFFECT GAS FIRE

INCORPORATING THE  
BAXI FIRES DIVISION **FireSlide** CONTROL

With

ALPHA, DECADENT,  
DREAM, ELEGANT,  
ETERNAL or  
OBSESSION fascia



(GC No. 32-032-58)

**THIS APPLIANCE IS FOR USE WITH NATURAL GAS (G20).  
WHEN CONVERTED USING CONVERSION KIT NO. 0595221 THIS  
APPLIANCE IS FOR USE WITH PROPANE GAS (G31).  
THIS APPLIANCE IS SUITABLE ONLY FOR INSTALLATION IN THE UNITED  
KINGDOM (GB) AND THE REPUBLIC OF IRELAND (IE).**

We trust that this guide gives sufficient details to enable this appliance to be operated and maintained satisfactorily. However, if further information is required, our **Baxi Fires Division Technical Helpline** will be pleased to help.  
Telephone **08706 061 065** (National call rates apply in the United Kingdom)  
In the Republic of Ireland telephone **0044 8706 061 065**.

This guide is intended to help you care for your gas fire. Please read thoroughly before using and keep for future reference.

# BAXI ● VALOR ● WONDERFIRE

**This guide to be left with the owner**

# OWNER GUIDE

## **Safety First.**

Baxi Fires Division fires are CE Approved and designed to meet the appropriate British Standards and Safety Marks.



## **Quality and Excellence.**

All Baxi Fires Division fires are manufactured to the highest standards of quality and excellence and are manufactured under a BS EN ISO 9001 quality system accepted by the British Standards Institute.



## **The Highest Standards**

Baxi Fires Division is a member of the Society of British Gas Industries which works to ensure high standards of safety, quality and performance.



## **Careful Installation**

Baxi Fires Division is a CORGI registered company. All our gas fires must be installed by a competent CORGI Registered Installer in accordance with our Installer Guide and should not be fitted directly on to a carpet or floor of combustible material.

# B A X I F I R E S D I V I S I O N

Baxi Fires Division, Erdington, Birmingham B24 9QP  
[www.firesandstoves.co.uk](http://www.firesandstoves.co.uk)

Because our policy is one of constant development and improvement, details may vary slightly from those given in this publication

# OWNER GUIDE

## LIST OF CONTENTS

<u>Section</u>	<u>Page</u>
<b>SAFETY</b>	<b>4</b>
<b>APPLIANCE DIMENSIONS</b>	<b>5</b>
<b>GAS CONSUMPTION</b>	<b>6</b>
<b>OPERATING YOUR FIRE</b>	<b>6</b>
The Oxysafe flame sensing and flue blockage safety system.	6
Lighting the pilot.	7
Lighting with a taper.	8
<b>CLEANING YOUR FIRE</b>	<b>8</b>
Metal Parts	8
Ceramic fuel effect and rear wall.	8
Burner.	9
<b>CERAMIC FUEL EFFECT REFITTING</b>	<b>9</b>
<b>MAINTENANCE</b>	<b>9</b>
Battery replacement.	9
Regular maintenance.	9
Servicing.	10
<b>USEFUL TELEPHONE NUMBERS</b>	<b>10</b>

---

This gas fire is designed to meet the most stringent quality, performance and safety requirements to provide you with many years' trouble-free service.

This guide aims to improve your understanding and appreciation of your gas fire by providing simple and informative instructions to ensure that you benefit from the excellent performance and features it has to offer.

# OWNER GUIDE

## SAFETY

### IF YOU SMELL GAS

**DON'T SMOKE**

**EXTINGUISH ALL NAKED FLAMES**

**DON'T TURN ELECTRICAL SWITCHES ON OR OFF**

**TURN OFF THE GAS SUPPLY AT THE METER**

**OPEN DOORS AND WINDOWS TO GET RID OF THE GAS**

**IMMEDIATELY CALL THE GAS EMERGENCY SERVICE – SEE YOUR LOCAL TELEPHONE DIRECTORY**

**Do** have the fire installed by a competent person. In the United Kingdom, installation must be in accordance with the latest edition of the Gas Safety (installation & use) Regulations. In the Republic of Ireland, installation must be in accordance with all national and local regulations in force.

**Do** have the chimney swept prior to installation if it was previously used for solid fuel.

**Do** have the fire installed in accordance with the installer guide.

**Do** provide a minimum clearance of 750mm from the top surface of the hearth to any shelf made of wood or other combustible material where the shelf is not more than 150mm deep. For a shelf deeper than 150mm, add 12.5mm to the clearance for every 25mm of additional shelf depth (See graph1).

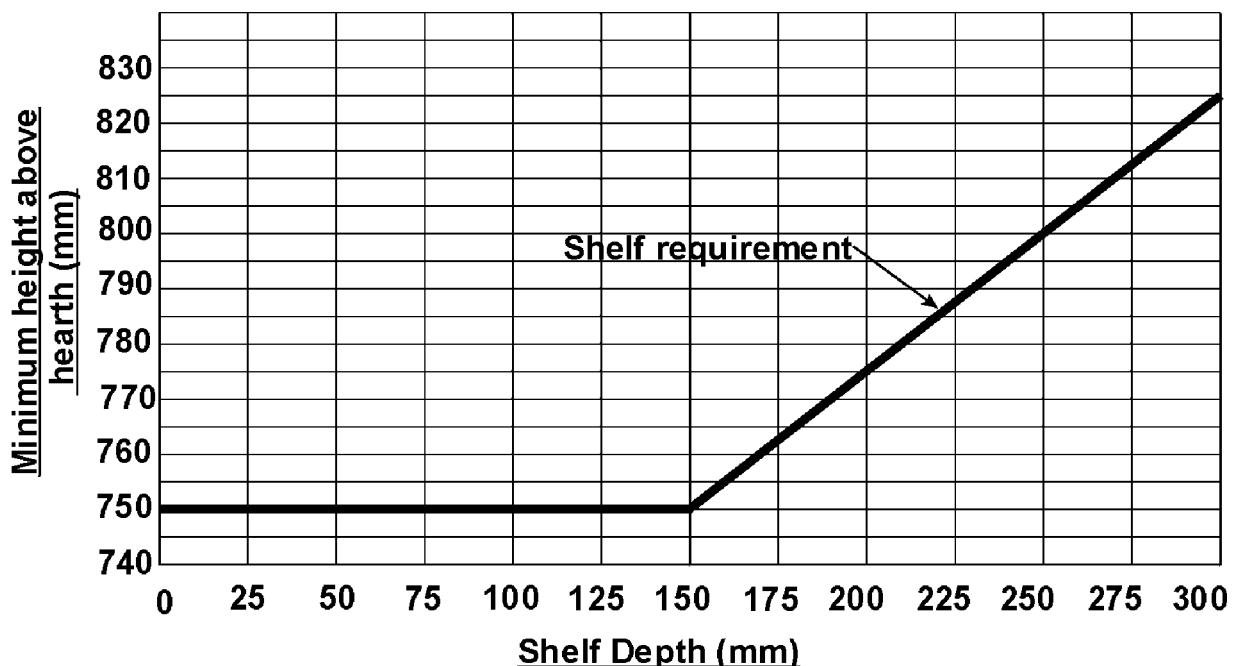

Graph 1. Combustible shelf clearances

**Do** always use a fireguard complying with BS 8423 for the protection of young children, the elderly or infirm.

**Do** wait three minutes before attempting to relight if the fire is switched off or the flames are extinguished for any reason. (Your fire is fitted with a safety device that will automatically shut off the gas supply to the fire, if for any reason, the flame goes out)

# OWNER GUIDE

**Do** get advice about the suitability of any wall covering near your fire. Soft wall coverings (e.g. embossed vinyl, etc.) which have a raised pattern are easily affected by heat. They may, therefore, scorch or become discoloured when close to a heating appliance. Please bear this in mind whenever you are considering redecorating.

**Do** provide a minimum side clearance as detailed in figure 1. Please bear this in mind if ever you are altering the room.

**Don't** hang clothing, towels or any other fabrics over the fire.

**Don't** put more ceramic fuel effect pieces on the fire than the number given in this guide or use any ceramic fuel effect pieces other than those authorised for this fire. This could cause incomplete combustion and subsequent safety hazard.

**Don't** put paper or other materials onto your fire.

**Don't** use the fire with damaged base ceramics.

**Don't** place any combustible material (rugs, carpet, plastic tiles, etc.) on the hearth

**Don't** attempt to clean or service the fire until it has been switched off and allowed to cool completely.

## APPLIANCE DIMENSIONS

100mm minimum mandatory clearance to combustible surfaces projecting beyond front of appliance. For access purposes a 10mm clearance is recommended to non-combustible surfaces

100mm minimum mandatory clearance to combustible surfaces projecting beyond front of appliance. For access purposes this is also the recommended to non-combustible surfaces

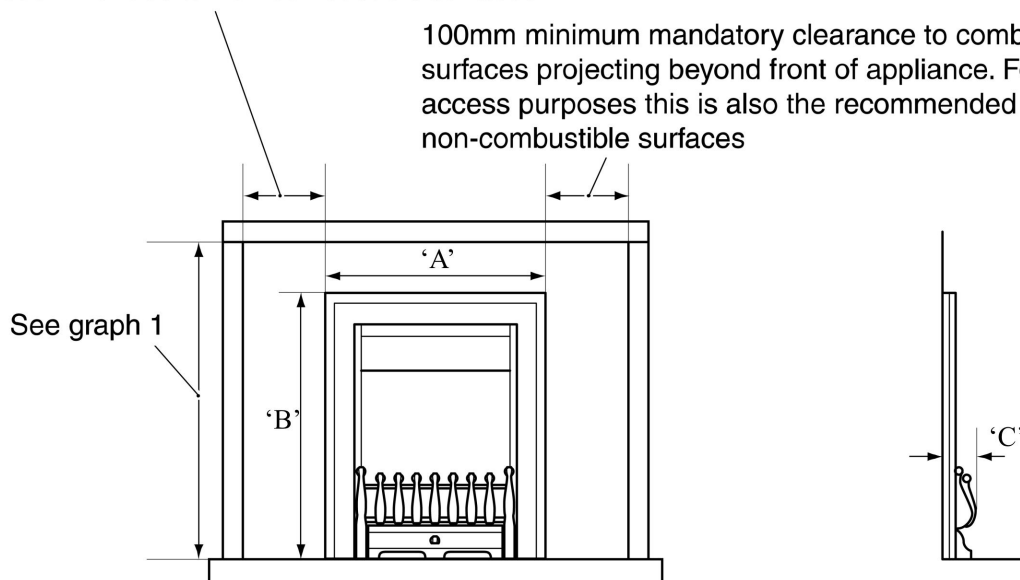

<u>Dimension</u>	<u>Alpha</u>	<u>Elegant</u>	<u>Dream</u>	<u>Eternal</u>	<u>Decadent</u>	<u>Obsession</u>
A	492mm	492mm	518mm	514mm	529mm	530mm
B	598mm	598mm	636mm	611mm	630mm	621mm
C	84mm	84mm	94mm	76mm	120mm	96mm

Figure 1. Appliance dimensions (Shown with Alpha / Elegant fascia)

# OWNER GUIDE

## GAS CONSUMPTION

### Model 750

Has a maximum natural gas input of 6.0kW (Gross)

Has a maximum natural gas output of 3.4kW

Has a minimum natural gas input of 2.7kW (Gross)

Has a minimum natural gas output of 1.4kW

### Model 750 when converted using kit number 0595221

Has a maximum propane gas input of 6.1kW (Gross)

Has a maximum propane gas output of 3.5kW

Has a minimum propane gas input of 4.3kW (Gross)

Has a minimum propane gas output of 2.4kW

## OPERATING YOUR FIRE

### *PLEASE NOTE*

When operating your fire for the first time, some vapours may be given off which may cause a slight odour and could possibly set off any smoke alarms in the immediate vicinity. These vapours are quite normal with new appliances. They are totally harmless and will disappear after a few hours use.

### **The Oxysafe flame sensing and flue blockage safety system.**

For your safety, this appliance is fitted with a flue blockage safety device which will shut down the appliance in the event of abnormal flue conditions. **This device is NOT a substitute for an independently mounted Carbon Monoxide detector.**

The device will also automatically shut off the gas supply to the fire if the pilot flame goes out due to lack of oxygen or for any other reason.

**If this device starts to repeatedly shut off the gas, get expert advice.**

This device incorporates a probe which senses that the heat from the pilot flame is correct. If this probe is cool, the device will prevent any gas flow unless the control knob is kept depressed at the ignition position.

If, for any reason, the flames go out when the fire is hot or if the fire is turned off when hot, **always wait at least three minutes before attempting to relight.**

# OWNER GUIDE

## Lighting the pilot.

The control markings are shown in figure 2.

- Slide the control button to the bottom (ignition)

position marked .

In this position, the electronic ignition system should cause a series of sparks that should light the pilot. Within four seconds of the pilot igniting, the main burner should light at its minimum setting.

If no sparks are produced to light the pilot, the battery may need replacing. Details of battery replacement are given further on in this manual. Until you can obtain a replacement battery the fire can be lit with a taper as described later in the instructions.

- Keep the button at the ignition position for a further ten seconds. This will prevent the flame sensing device from shutting off the gas while its probe warms up as explained above.
- If low heat is required, release the button. The button will automatically spring up to the low heat position shown in figure 2 (See note i).
- For a higher heat level slide the button upwards. The burner flames and heat output will gradually increase until the button reaches the high heat position shown in figure 2. When the button reaches the high heat position you will feel a check to its movement. Do not slide the button above the high heat position unless you want to turn the fire off (See note i).

### Note

- If the flames go out while setting the control, repeat the full lighting procedure. If the flames repeatedly go out have the fire serviced.
- When first turned on the flames will appear predominantly blue. The ceramic fuel effect pieces will take time to warm up. Although some glow will be seen after approximately ten minutes, the full visual effect will only be apparent after a somewhat longer time.
- The appliance will operate to its maximum potential if the flue is primed during the first 20 - 30 minutes of operation. To do this, simply slide the control to its highest setting. This will also burn off any carbon deposits that may have formed during previous operations.
- If operating the appliance for long periods it is beneficial to change between settings. This will also help to remove any carbon deposits that may form during operation.

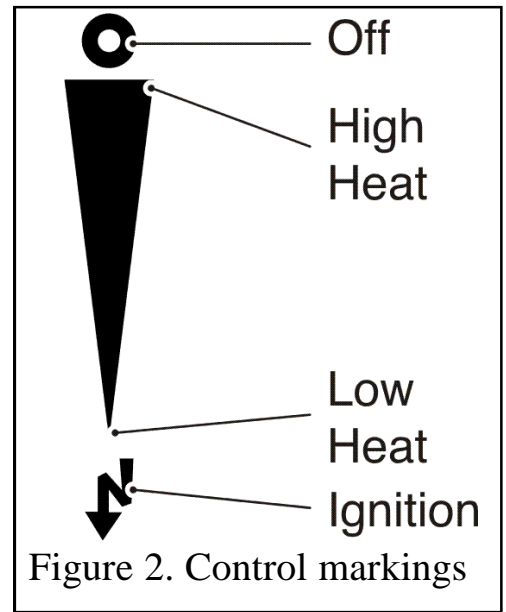

Figure 2. Control markings

# OWNER GUIDE

## Lighting with a taper.

(See figure 3).

In the unlikely event of failure of the ignition spark, the pilot can be lit by a taper or long spill. Insert the taper or spill through the lower left hand opening in the front of the ceramic fuel effect.

- Follow the section ‘ Lighting the pilot’ as described previously.

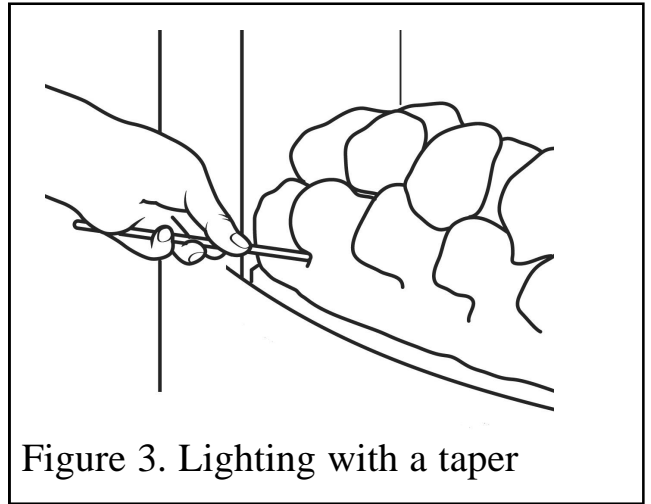

Figure 3. Lighting with a taper

## CLEANING YOUR FIRE

To maintain the high performance and quality finish of your Baxi Fires Division appliance, please follow these guidelines:

- Before attempting to clean the fire, please remember to turn off the fire and wait for the appliance to cool. The fire will retain heat for some time before cleaning can begin.
- If any pieces of debris are found in the firebox, have the chimney inspected before further use.

### Metal Parts.

- Clean the metal parts with a slightly damp, lint free non-abrasive cloth and then dry.
- Do **not** use abrasive cleaners, as these will scratch the fire surface.

### Ceramic fuel effect and rear wall.

- **This product uses fuel effect pieces and burner compartment rear wall containing Refractory Ceramic Fibres (RCF), which are man-made vitreous silicate fibres. Excessive exposure to this material may cause irritation to eyes, skin and respiratory tract. Consequently, it is important to take care when handling these articles to ensure that the release of dust is kept to a minimum.**
- Light coatings of soot will usually be burnt off during the normal operation of the fire.
- Should any soot accumulation become excessive, the fuel effect pieces and walls should be removed from the fire for cleaning.
- Cleaning should be carried out in a well ventilated area or in the open air by gently brushing with the pieces held away from your face so that you avoid inhaling the dust.
- We suggest that you remove the ceramic fuel effect pieces in the reverse order to that shown in the fuel bed refitting instructions.



# OWNER GUIDE

## **Burner.**

- The burner surface can be carefully cleaned to remove any loose particles after taking off the ceramic fuel effect pieces. Make sure that no particles are pushed into the burner holes.

## **CERAMIC FUEL EFFECT REFITTING**

The installer and owner guide for the ceramic fuel effect is separate from this guide. The installer may have attached it to this guide or placed it inside. It is important that the installer and owner guide for the ceramic fuel effect is followed correctly. If replacing the ceramic fuel effect, where a new guide is supplied, follow the installer and owner guide supplied with the replacement fuel effect.

Keep the replacement installer and owner guide with this owner guide for future reference.

## **MAINTENANCE**

### **Battery replacement.**

The igniter unit uses a 9V PP3 battery. To replace the battery remove the firefront casting / front cover casting.

1. Remove and discard the battery from the ignition block located below the burner tray at the left side.
2. Fit the replacement battery to the ignition block. (See figure 4). The positive terminal (+) is to the top as you insert.
3. Replace the firefront casting / front cover casting.

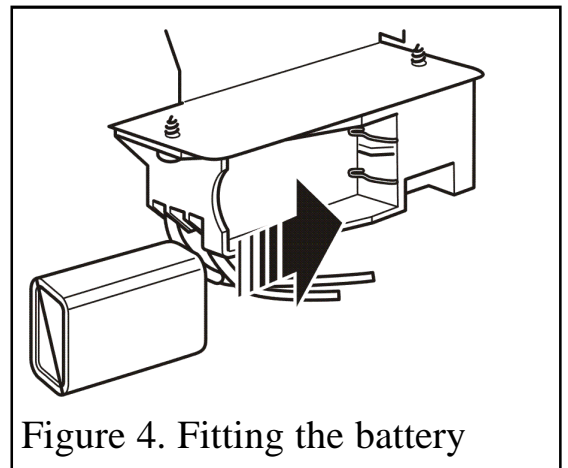

Figure 4. Fitting the battery

### **Regular maintenance.**

In order to achieve and maintain high levels of personal safety and performance efficiency, it is essential that the opening at the back of the fire and the flue are kept clear of any form of obstruction. It is possible that deposits of mortar or soot could fall and accumulate causing the flue to be blocked or restricted and so preventing proper clearance of dangerous exhaust fumes.

In the United Kingdom it is the law that a landlord must have any gas appliance, flue and pipework which is situated in a tenant's premises checked for safety at least every twelve months by a competent person (In the U.K, a CORGI registered installer).

We recommend that all gas appliances and their flues, wherever situated, are checked annually.

# OWNER GUIDE

## **Servicing.**

- In the United Kingdom servicing can be carried out either by a Baxi Fires Division service engineer or a CORGI registered installer.
- If you require your fire to be serviced, please contact **Baxi Fires Division Service** on **08706 090 081** and quote the following details;

## **IMPORTANT**

**To help us quickly help you, please try to have the following information available before you contact us:**

**Type of fire.**

**Model/Name.**

**Serial Number.**

**You will also be asked for the fault, problem or request plus your Post Code.**

- If you wish to replace any of the ceramic fuel effect pieces, spare parts are available nationwide via the ‘**interpart** stockist network’. For your local stockist consult Yellow pages under Central Heating.
- **When fitting replacement parts, follow the instructions contained in this guide. It is important that only Baxi Fires Division approved parts are used for maximum safety.**

## USEFUL TELEPHONE NUMBERS

General advice about gas and your gas fire:

**BAXI FIRES DIVISION TECHNICAL HELPLINE      08706 061 065.**

To report faults or arrange for your fire to be serviced:

**BAXI FIRES DIVISION SERVICE      08706 090 081.**

For sales or product information:

**BAXI FIRES DIVISION SALES      08706 061 067.**

To order spares

**Spare parts are available nationwide via the ‘interpart stockist network’. For your local stockist consult Yellow pages under ‘Central Heating’.**

CALLERS IN THE REPUBLIC OF IRELAND

Call    **0044 8706 061 065**