

BAXI FIRES DIVISION

INSTALLER GUIDE

Model 750

INSET LIVE FUEL EFFECT GAS FIRE

INCORPORATING THE
BAXI FIRES DIVISION **FireSlide** CONTROL

With

ALPHA,
ELEGANT,
DREAM or

ETERNAL fascia

(GC No. 32-032-58)



**THIS APPLIANCE IS FOR USE WITH NATURAL GAS (G20)
WHEN CONVERTED USING CONVERSION KIT NO. 0595221 THIS
APPLIANCE IS FOR USE WITH PROPANE GAS (G31)
THIS APPLIANCE IS SUITABLE ONLY FOR INSTALLATION IN THE UNITED
KINGDOM (GB) AND THE REPUBLIC OF IRELAND (IE).**

We trust that these instructions give sufficient details to enable this appliance to be installed and maintained satisfactorily. However, if further information is required, our

Baxi Fires Division Technical Helpline will be pleased to help.

Telephone **08706 061 065** (National call rates apply in the United Kingdom)

In the Republic of Ireland telephone **0044 8706 061 065**

BAXI ● VALOR ● WONDERFIRE

INSTALLER: Please leave this guide with owner

INSTALLER GUIDE

Safety First.

Baxi Fires Division fires are CE Approved and designed to meet the appropriate British Standards and Safety Marks.



Quality and Excellence.

At the heart of every Baxi Fires Division fire.

All Baxi Fires Division fires are manufactured to the highest standards of quality and excellence and are manufactured under a BS EN ISO 9001 quality system accepted by the British Standards Institute.



The Highest Standards

Baxi Fires Division is a member of the Society of British Gas Industries which works to ensure high standards of safety, quality and performance.



Careful Installation

Baxi Fires Division is a CORGI registered company. All our gas fires must be installed by a competent CORGI Registered Installer in accordance with our Installer Guide and should not be fitted directly on to a carpet or floor of combustible material.

B A X I F I R E S D I V I S I O N

Baxi Fires Division, Erdington, Birmingham B24 9QP
www.firesandstoves.co.uk

Because our policy is one of constant development and improvement, details may vary slightly from those given in this publication

INSTALLER GUIDE

CONTENTS

<u>Section</u>	<u>Heading</u>	<u>Page</u>
1.	SAFETY	4
2.	APPLIANCE DATA	4
3.	GENERAL INSTALLATION REQUIREMENTS	5
4.	PACK CONTENTS	12
5.	FIREPLACE CHECK	14
6.	IGNITION CHECK	15
7.	GAS SUPPLY CONNECTION	15
8.	PREPARING APPLIANCE FOR INSTALLATION	16
9.	CONVECTION BOX INSTALLATION	17
	9.1 Method 1- Front fixing to fireplace surround.	17
	9.2 Method 2 - Cable retention.	18
	9.3 Floor sealing.	19
10.	BURNER INSTALLATION	20
11.	FITTING THE FASCIA	21
12.	FITTING THE CERAMIC FUEL EFFECT	22
13.	FIREFRONT CASTING INSTALLATION	22
14.	FULL OPERATING CHECKS	23
15.	SPILLAGE AND FLAME SUPERVISION CHECKS	24
16.	FINAL REVIEW	25
17.	SERVICING & PARTS REPLACEMENT	26
	17.1 Checking the aeration setting of the burner.	27
	17.2 To remove the ignition microswitch.	27
	17.3 To remove the gas shut-off microswitch	28
	17.4 To remove the fascia.	28
	17.5 To replace the control slide button.	29
	17.6 To remove the burner unit.	29
	17.7 To remove the electronic ignition generator.	29
	17.8 To remove the thermocouple interrupter block.	30
	17.9 To remove the pilot unit.	30
	17.10 To remove the shut-off tap.	30
	17.11 To remove the gas flow rate controller.	31
	17.12 To replace the burner.	32
	17.13 To remove the main burner injector.	32
	17.14 To remove the appliance from the fireplace.	32

INSTALLER GUIDE

1. SAFETY

Installer

Before continuing any further with the installation of this appliance please read the following guide to manual handling.

- The lifting weight of this appliance is as below: -

<u>Model</u>	<u>Weight (Kg)</u>
Alpha	10
Dream	18
Elegant	10
Eternal	11.15

- One person should be sufficient to lift the fire. If for any reason this weight is considered too heavy then obtain assistance.
- When lifting always keep your back straight. Bend your legs and not your back.
- Avoid twisting at the waist. It is better to reposition your feet.
- Avoid upper body/top heavy bending. Do not lean forward or sideways whilst handling the fire.
- Always grip with the palm of the hand. Do not use the tips of fingers for support.
- Always keep the fire as close to the body as possible. This will minimise the cantilever action.
- Use gloves to provide additional grip.
- Always use assistance if required.

2. APPLIANCE DATA

This product uses fuel effect pieces and a burner compartment rear wall containing Refractory Ceramic Fibres (RCF), which are man-made vitreous silicate fibres. Excessive exposure to these materials may cause irritation to eyes, skin and respiratory tract. Consequently, it is important to take care when handling these articles to ensure that the release of dust is kept to a minimum. To ensure that the release of fibres from these RCF articles is kept to a minimum, during installation and servicing we recommend that you use a HEPA filtered vacuum to remove any dust and soot accumulated in and around the fire before and after working on the fire. When replacing these articles we recommend that the replaced items are not broken up, but are sealed within a heavy duty polythene bag, clearly labelled as RCF waste. This is not classified as “hazardous waste” and may be disposed of at a tipping site licensed for the disposal of industrial waste.

INSTALLER GUIDE

Protective clothing is not required when handling these articles, but we recommend you follow the normal hygiene rules of not smoking, eating or drinking in the work area and always wash your hands before eating or drinking.

This appliance does not contain any component manufactured from asbestos or asbestos related products.

Gas	Natural (G20)	Propane (G31) *
Inlet Pressure	20mbar	37mbar
Input - Max. (Gross)	6.0kW (20,500Btu/h)	6.1kW (20,800Btu/h)
Input - Min. (Gross)	2.7kW (9,212Btu/h)	4.3kW (14,670Btu/h)
Inlet Test Pressure (Cold)	20.0 ± 1.0mbar (8.0 ± 0.4in w.g.)	37.0 ± 1.0 mbar (14.85 ± 0.4in w.g.)
Gas Connection	8mm pipe	8mm pipe
Burner Injector	Stereomatic Cat 82 - 069	Stereomatic Size 128
Pilot & Atmosphere Sensing Device	Copreci Ref. O.D.S 21500/166	Copreci Ref. O.D.S 21500/166 Fitted with RBM 180 - 02 injector
Ignition	Electronic (Battery 9V PP3)	Electronic (Battery 9V PP3)
Aeration	See section 17.1	Non-adjustable

* When converted using Kit 0595221

The appliance data label is located on a plate at the base of the fire. This can be seen by removing the front cover casting.

3. GENERAL INSTALLATION REQUIREMENTS

3.1 The installation must be in accordance with this guide.

For the user's protection, in the United Kingdom it is the law that all gas appliances are installed by competent persons in accordance with the current edition of the Gas Safety (Installation and Use) Regulations. Failure to install the appliance correctly could lead to prosecution. The Council for the Registration of Gas Installers (CORGI) requires its members to work to recognised standards.

In the United Kingdom the installation must also be in accordance with:

All the relevant parts of local regulations.

All relevant codes of practice.

The relevant parts of the current editions of the following British Standards: -

BS 715 BS 1251 BS 1289 Part 1 BS EN 1806

BS 4543 Part 2 BS 5440 Part 1 BS 5440 Part 2 BS 5871 Part 1

BS 6461 Part 1 BS 6891

INSTALLER GUIDE

In England and Wales, the current edition of the Building Regulations issued by the Department of the Environment and the Welsh Office

In Scotland, the current edition of the Building Standards (Scotland) Regulations issued by the Scottish Executive.

In Northern Ireland, the current edition of the Building regulations (Northern Ireland) issued by the Department of the Environment for Northern Ireland.

In the republic of Ireland the installation must be carried out by a competent person and installed in accordance with:

- a) The current edition of IS 813 “Domestic gas installations”
- b) All relevant national and local rules in force.
- c) The current building regulations

Where no specific instructions are given, reference should be made to the relevant British Standard Code of Practice.

3.2 In the United Kingdom, as supplied, this appliance can be installed in the following situations: -

3.2.1 A masonry chimney with a minimum diameter of 175mm (7”) free from any obstruction, and with any damper or restrictor plate in the chimney removed or secured, and having a minimum effective flue height of 3m (10ft). A masonry chimney having a correctly installed flue liner to BS715 and with a minimum flue diameter of 125mm is also acceptable. Chair brick removal may not be required providing at least 50mm clearance is available from the flue outlet to any fireplace component.

3.2.1.1 ‘Hole-in-the-wall’ Installations

- It is recommended that a hearth should be installed as in figure 1.
- If a hearth is not fitted, the fire must be installed so that the distance from the base of the fireplace opening in the wall to the finished floor level is at least 72mm. The minimum shelf height will have to be taken from the base of the fireplace opening.

3.2.2 To a fireplace incorporating a metal flue box conforming to BS715

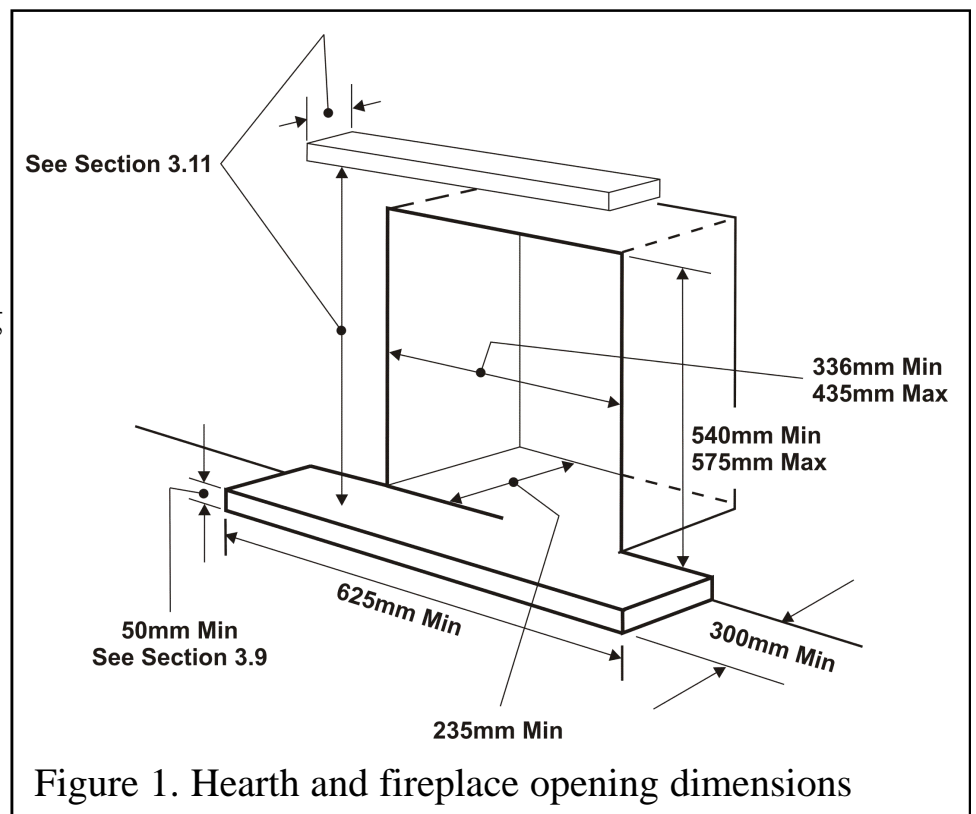

Figure 1. Hearth and fireplace opening dimensions

INSTALLER GUIDE

with a minimum internal depth of 165mm. Incombustible mineral wool insulation of not less than 50mm thickness must be applied to the top surface of the firebox (See figure 2) and it must stand on a non-combustible hearth (See figure 1).

3.2.3 (See figure 3)

To a fireplace that has a precast concrete or clay flue block system conforming to BS1289 or BS EN 1806. The appliance is suitable for installations conforming to older versions of BS1289 as well as the current edition. The flue blocks must have a minimum width not less than 63mm and a cross-sectional area not less than $13,000\text{mm}^2$. Older editions of BS1289 required a cross-sectional area of $13,000\text{mm}^2$. The current revision of the standard requires $16,500\text{mm}^2$. This appliance is suitable in both cases. The total depth of the opening measured from the finished front of the fireplace (Including plaster, surround etc.) must be as below:

- If the width at the rear of the precast flue starter blocks is 300mm or greater the depth of the opening is to be not less than 138mm. Under these conditions the eyebolts will need to be located as close to the sides of the starter blocks as possible.

- If the width at the rear of the precast flue starter blocks is less than 300mm then an additional 16mm of depth will be required to accommodate the eye bolts.

Therefore if the starter blocks are less than 300mm wide the minimum depth of

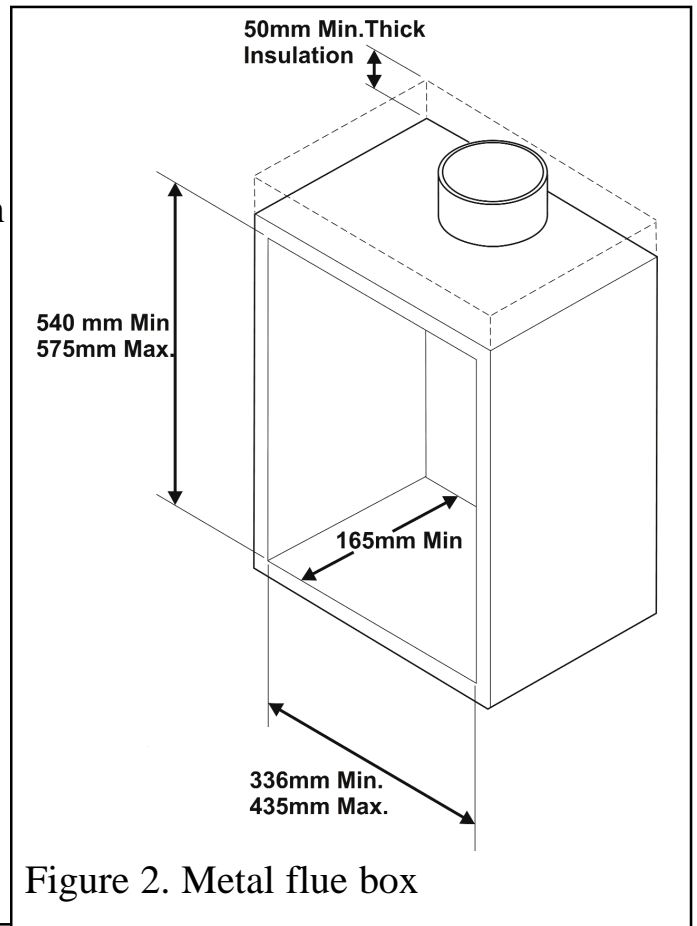

Figure 2. Metal flue box

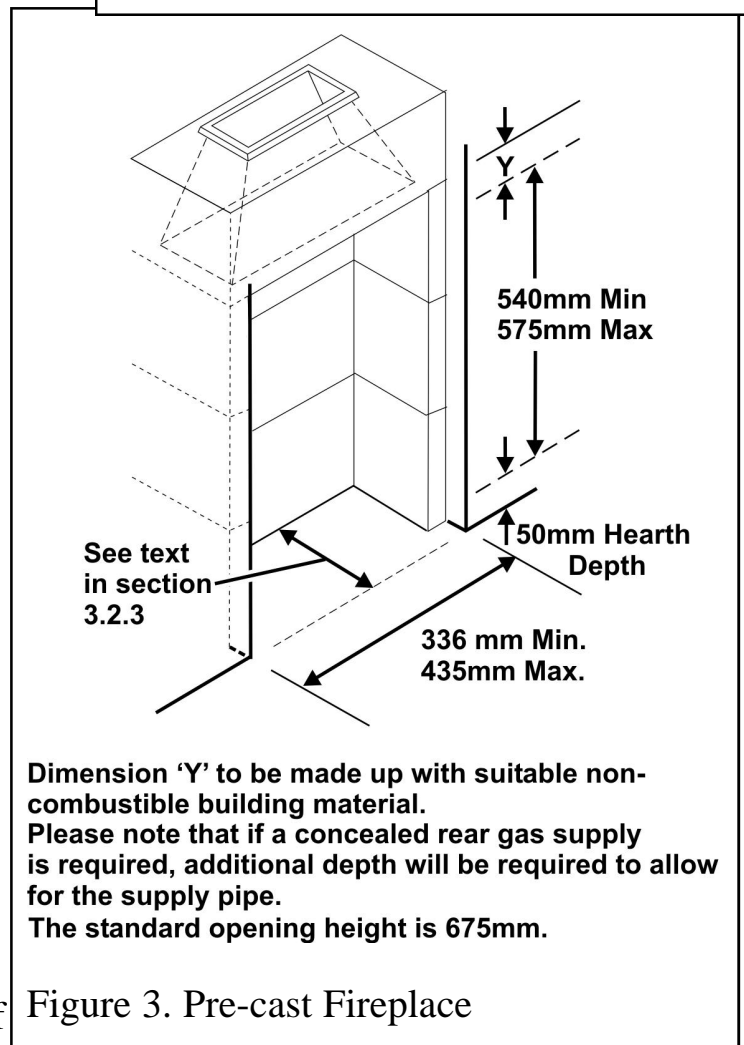

Figure 3. Pre-cast Fireplace

INSTALLER GUIDE

the opening will be not less than 154mm.

The current versions of BS1289 and BS EN 1806 recommend that there should be an air space or insulation between the flue blocks and the plaster because heat transfer may cause cracking on directly plastered flues. However, generally this appliance is suitable for installations under all circumstances unless there is a history of cracking problems. Remember that faults such as cracking may be caused by poorly built and restrictive flues, e.g. mortar extrusions, too many bends, flue heights below three metres, restrictive terminations, etc.

3.2.4 If the fireplace opening is greater than the acceptable dimensions given in this guide, do not use the back of a fire surround or marble to reduce the opening. This may cause cracking of the surround back or marble.

3.3 The following flues are suitable:

- 225mm x 225mm conventional brick flue.

If a flue liner is used, it must be a minimum of 125mm diameter. The liner must be sealed to the surrounding area above the fireplace opening and to the top of the chimney. An approved terminal must be fitted.

- 200mm diameter factory made insulated flue manufactured to BS 4543.
- A properly constructed precast flue conforming to B.S 1289 or BS EN 1806.
- A flue pipe with a minimum diameter of 175mm. See B.S 6461 Part 1 for suitable materials. Metal flue pipes must comply with B.S 715.
- Single wall, twin wall or flexible flue liner of minimum diameter 125mm. The materials used are stainless steel or aluminium as specified in B.S. 715.

3.3.1 The minimum effective height of the flue must be 3m.

3.3.2 The flue must be clear of any obstruction and its base must be clear of debris.

3.3.3 The flue must be completely sealed so that combustion products do not come into contact with combustible materials outside the chimney.

3.3.4 The flue must serve only one fireplace.

3.4 The flue must conform to BS 5440: Part 1 in design and installation.

The flue, measured from the bottom of the fireplace opening to the bottom of the terminal, shall be not less than 3m in actual vertical height. When calculated in accordance with BS 5440: Part 1 Annex A, the minimum **equivalent** height of the flue shall be 2.0m of 125mm dia. flue pipe.

3.5 The flue must not be used for any other appliance or application.

3.6 Any chimney dampers or restrictors should be removed. If removal is not possible they must be fixed in the open position.

INSTALLER GUIDE

3.7 If the appliance is intended to be installed to a chimney, which was previously used for solid fuel, the flue must be swept clean prior to installation. All flues should be inspected for soundness and freedom from blockages.

3.8 If the fireplace opening is an underfloor draught type, it must be sealed to stop any draughts.

3.9 The appliance must be mounted behind a non-combustible hearth (N.B. conglomerate marble hearths are considered as non-combustible). The appliance can be fitted to a purpose made proprietary class “O”-150°C surround. The hearth material must be at least 12mm thick. The periphery of the hearth (or fender) should be at least 50mm above floor level to discourage the placing of carpets or rugs over it. The appliance must not stand on combustible materials or carpets (See figure 1).

3.10 The front face of the fireplace should be reasonably flat over the area covered by the convector box top and side flange seals to ensure good sealing. These faces should be made good if necessary. The fireplace floor should be reasonably flat to ensure that a good seal with the convector box can be made.

3.11 The minimum height from the top surface of the hearth to the underside of any shelf made from wood or other combustible materials is detailed below.

- For a shelf up to 150mm deep: Minimum height = 750mm.
- For a shelf deeper than 150mm: 750mm + 12.5mm for every 25mm depth over 150mm. (See Graph 1)

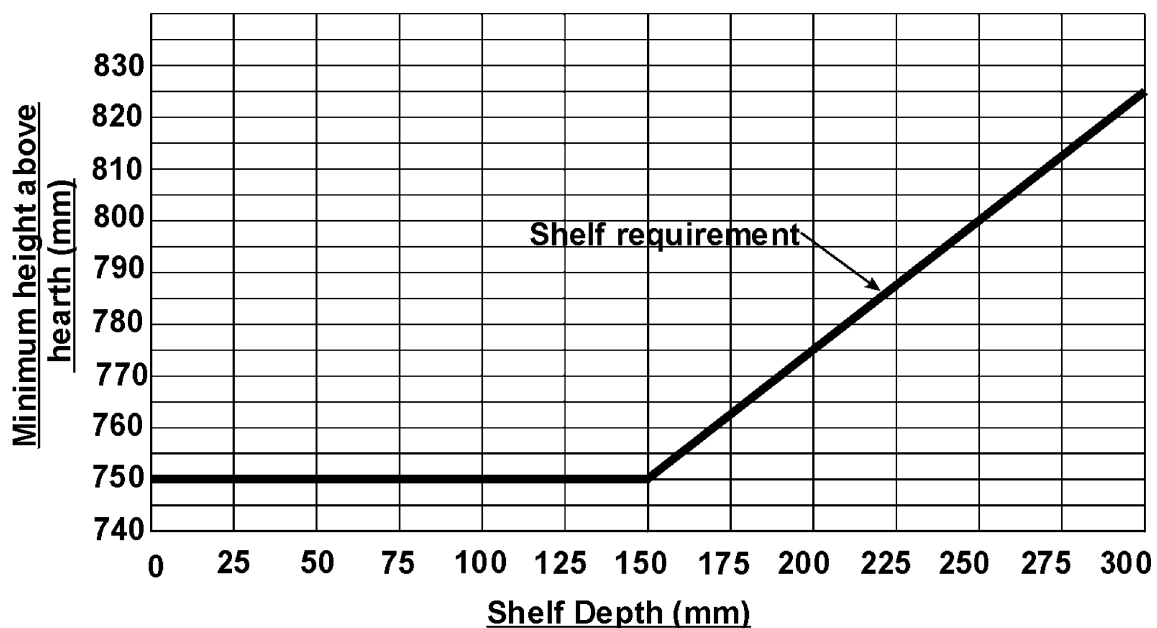

Graph 1. Combustible shelf clearances

INSTALLER GUIDE

3.12 Note that soft wall coverings (e.g. embossed vinyl, etc.) are easily affected by heat. They may scorch or become discoloured when close to a heating appliance. Please bear this in mind when installing.

3.13 The appliance must not be installed in any room, which contains a bath, or shower or where steam is regularly present.

3.14 An extractor fan may only be used in the same room as this appliance, or in any area from which ventilation for the appliance is taken, if it does not affect the safe performance of the appliance. Note the spillage test requirements detailed further on in this manual. If the fan is likely to affect the appliance, the appliance must not be installed unless the fan is permanently disconnected.

3.15 Normal adventitious ventilation is usually sufficient to satisfy the ventilation requirements of this appliance. In GB reference should be made to BS 5871 Part 2 and in IE reference should be made to the current edition of IS 813 “Domestic gas Installations” which makes clear the conditions that must be met to demonstrate that sufficient ventilation is available.

3.16 Propane gas appliances must not be installed in a room, which is built entirely below ground level (See BS 5871 Pt2).

3.17 Proprietary terminals must comply with BS 715 or BS 1289. Any terminal or termination must be positioned in accordance with BS 5440 Part 1 to ensure that the products of combustion can be safely dispersed into the outside atmosphere. Where the appliance is connected to an unlined brick chimney it is generally unnecessary for the chimney pot to be replaced or for a terminal to be fitted unless the flue has a diameter smaller than 170mm.

3.18 The appliance is fitted with an A.S.D (Atmosphere sensing device). If the appliance closes down after a period of operation for no apparent reason, the consumer should be informed to stop using the appliance until the installation and appliance have been thoroughly checked. The A.S.D will shut the appliance down if an unacceptable amount of harmful products of combustion accumulate. Under no circumstances should the A.S.D be altered or bypassed in any way. Only a genuine manufacturers replacement part should be fitted. The individual A.S.D components are not replaceable.

3.19 A fireguard complying with BS 8423 should be fitted for the protection of young children, the elderly, or the infirm.

INSTALLER GUIDE

100mm minimum mandatory clearance to combustible surfaces projecting beyond front of appliance. For access purposes a 10mm clearance is recommended to non-combustible surfaces

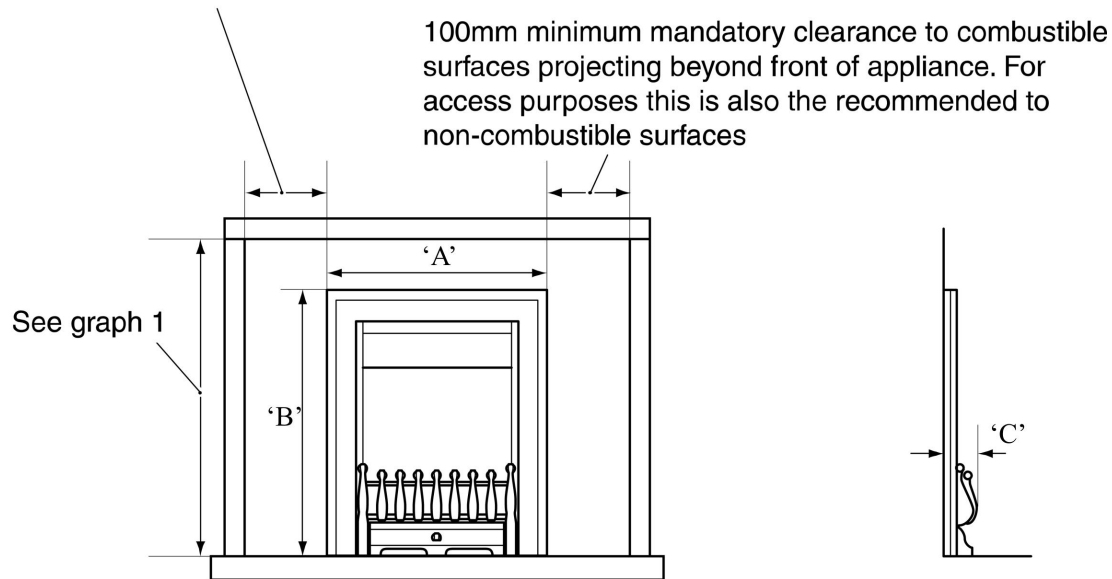

<u>Dimension</u>	<u>Alpha</u>	<u>Elegant</u>	<u>Dream</u>	<u>Eternal</u>
A	492mm	492mm	518mm	514mm
B	598mm	598mm	636mm	611mm
C	84mm	84mm	94mm	76mm

Figure 4. Appliance dimensions (Shown with Alpha / Elegant fascia).

3.20 The minimum allowable distance from the outside of the fascia to a corner wall having combustible material or any other combustible surface which projects beyond the front of the appliance is shown in figure 4.

For access purposes the recommended clearances to non combustible surfaces are shown in figure 4.

3.21 If the appliance is to be fitted against a wall with combustible cladding, the cladding must be removed from the area covered by the fascia. The cladding must also not touch the fascia (See figure 5). We suggest that the actual fascia is used as a template to mark the area for combustible cladding removal and that this area is increased by at least 2mm all round.

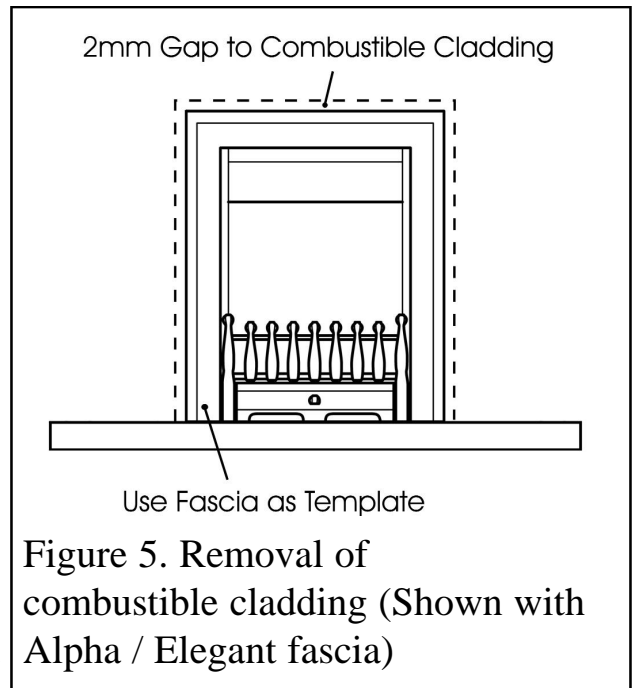

Figure 5. Removal of combustible cladding (Shown with Alpha / Elegant fascia)

INSTALLER GUIDE

4. PACK CONTENTS

The items required for this appliance are packed in sections.

Section 1 - Fire unit contains:

- 1 Convection box and burner assembly
- 1 Loose parts pack including: -
- 1 Grommet for rear of convection box
- 1 Nut and olive for 8mm inlet pipe
- 1 Strip of floor sealing tape
- 1 Flue restrictor with 2 securing screws
- 4 Fibre plugs
- 4 Woodscrews
- 2 Tension cables
- 2 Cable adjusters
- 2 Eyebolts
- 1 Length of self-adhesive foam seal
- 1 Inlet "T" connector including pressure test point
- 1 Burner tray trim (Not supplied on 'Eternal')
- 1 Control position label for Dream and Eternal.
- 1 Battery
- 1 Ceramic fuel effect pack (Not shown)

Section 2 - Fire front contains

- 1 Firefront casting
- 1 Front cover casting.
- 1 Firefront fascia

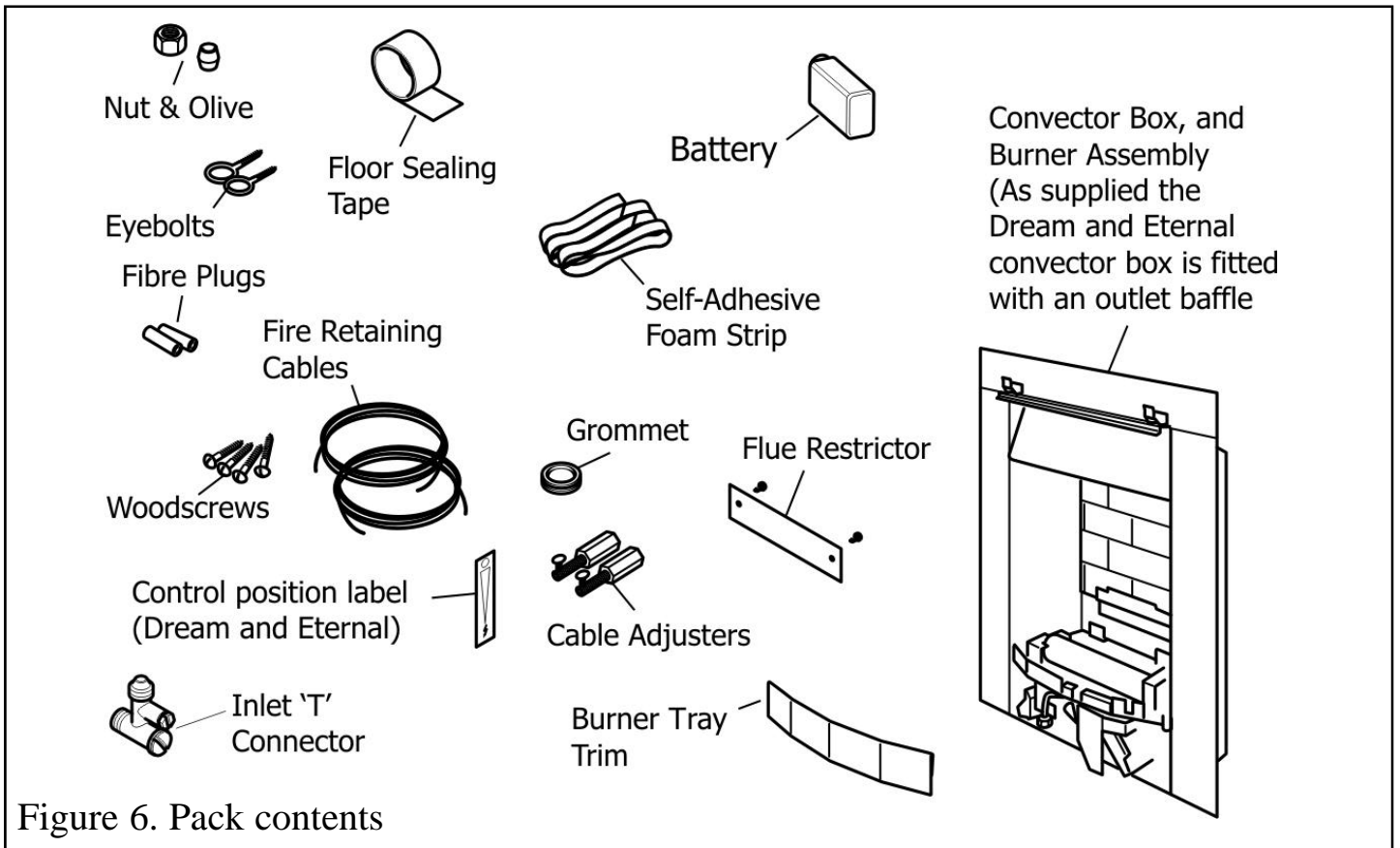
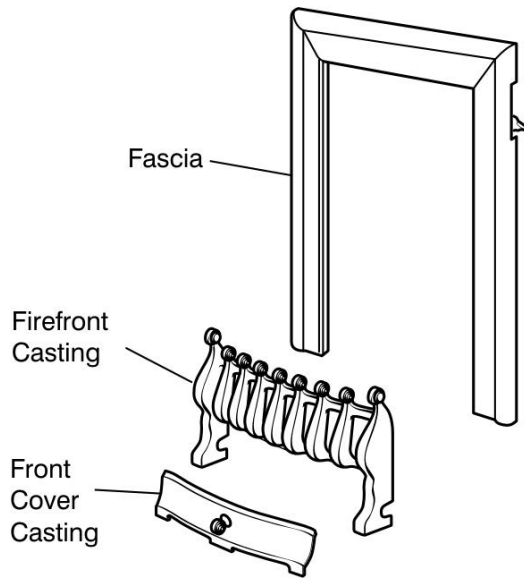

Figure 6. Pack contents

INSTALLER GUIDE

Alpha, Elegant



Eternal

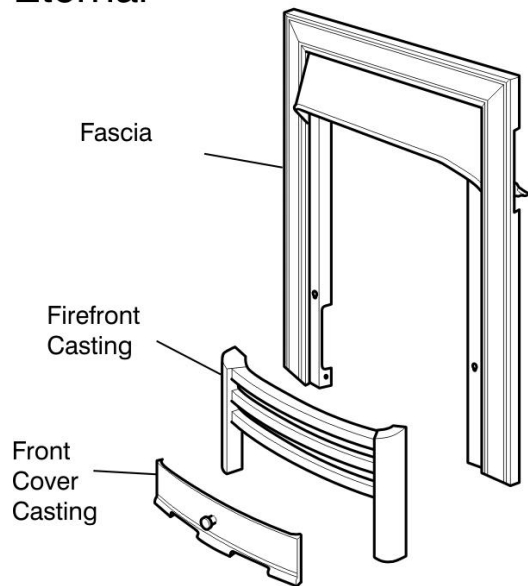

Dream

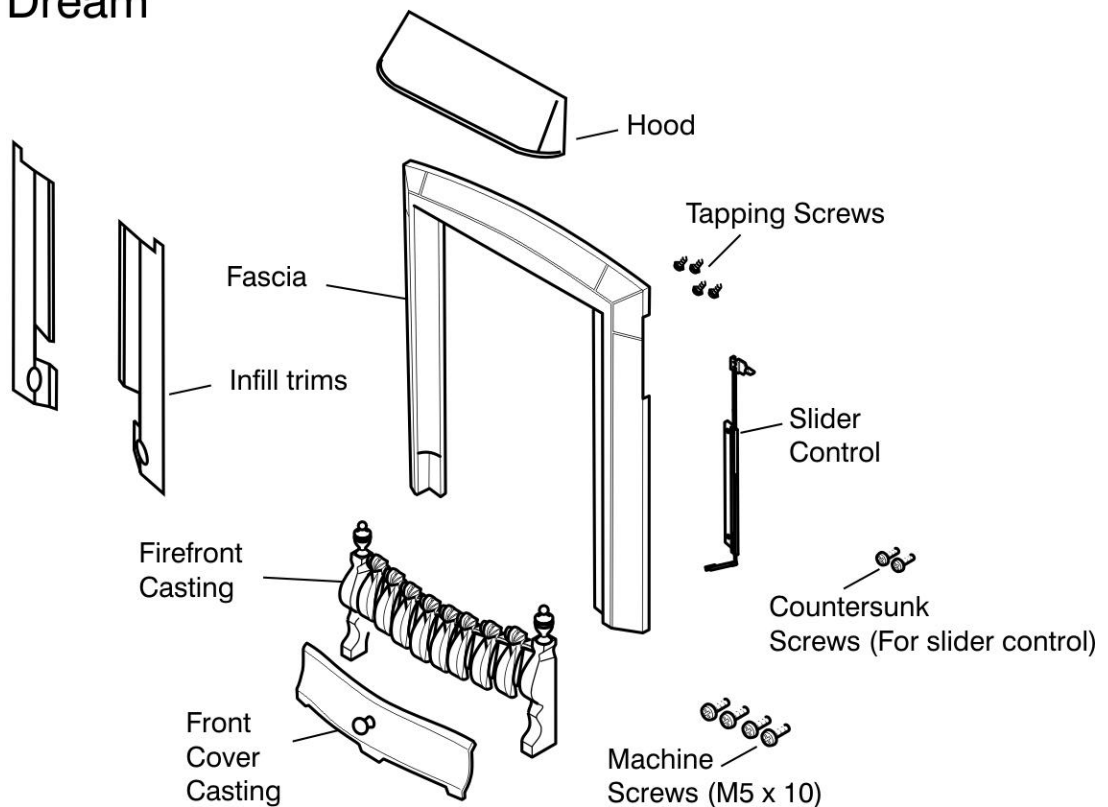

Figure 6. Pack contents continued

Remove all the items carefully to prevent damage. Take special care when handling the ceramic components. Some items may be contained in the packaging fitments - Examine the packaging carefully before discarding. Check that all the items are present and undamaged.

INSTALLER GUIDE

5. FIREPLACE CHECK

5.1 Fireplace check.

5.1.1 Fireplace size

The fireplace must comply with the requirements described in section 3.2. This may entail removing the fireback and infill material behind the fireback.

5.1.2 Fireplace general condition

The fireplace floor should be reasonably flat to ensure that the convector box can be installed without it rocking and so that a good seal can be made at the bottom front of the box. The front face of the fireplace should be reasonably flat over the area covered by the convector box top and side flange seals to ensure good sealing. These faces should be made good if necessary. If the appliance is to be fitted against a wall with combustible cladding, the cladding must be removed from the area covered by the fascia. The cladding must also not touch the fascia (See figure 5). We suggest that the fascia is used as a template to mark the area for combustible cladding removal and that this area is increased by at least 2mm all round.

5.1.3 Soundness for appliance attachment

Two primary methods of retaining the appliance are provided: -

- 1) By fixing to the fireplace front surround.
- 2) Using concealed tension cables fixed to the rear of the fireplace opening together with secondary fixing to the fireplace floor.

The methods are detailed in section 9 of this manual. Before selecting the retention method, consult with the customer. Method 2 is provided for instances where drilling holes in the front surface of the fireplace surround is unacceptable to the customer or otherwise impractical. *N.B. It is unwise to attempt to drill into marble without the proper tools and equipment.*

If method 1 is chosen, make sure that the front surround area is sound enough to take the fibre plugs and woodscrews. If necessary, make sound with a suitable cement.

If method 2 is chosen, make sure that the areas at the back is sound enough to take the eyebolts. If these areas have deteriorated due to prolonged use, they should be made sound with a suitable cement.

5.1.4 Installations using a metal flue box

The whole of the top surface of the metal flue box must be covered with a minimum 50mm layer of mineral wool or equivalent insulation (See figure 2).

5.2 Fireplace flue pull.

Close all doors and windows in the room in which the appliance is to be installed. After confirming with a match that smoke is drawn into the flue, light a 13 gram smoke pellet and check that there is a definite flow through the flue. Verify outside that the smoke exits from one terminal only and that the termination is suitable. Observe where

INSTALLER GUIDE

possible, upstairs rooms and loft spaces for signs of escaping smoke indicating a defective flue. If there is not a definite flow warm the flue for a few minutes and repeat the smoke pellet test. If there is still no definite flow the flue may need remedial work – **Do not fit the appliance until there is a definite flow through the flue.**

6. IGNITION CHECK

Before attempting to install, it is worth checking that the electronic ignition system performs satisfactorily.

Fit the battery to the ignition block located below the burner tray at the left side (See figure 7). The positive terminal (+) is to the top as you insert.

- Depress the slider as far as it will go. This should close the ignition circuit. Sparks should be seen tracking from the electrode pin to the pilot tip (See figure 8).
- If there are no sparks make the following checks.
- Check condition of battery and that it is correctly fitted.
- If the above is satisfactory, check the ignition circuit and components - see the servicing section in this manual.

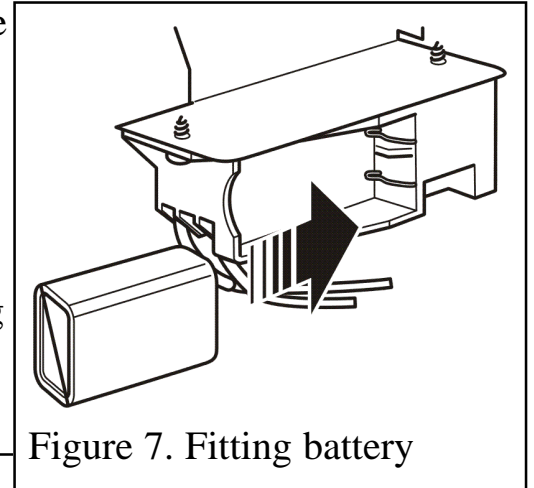

Figure 7. Fitting battery

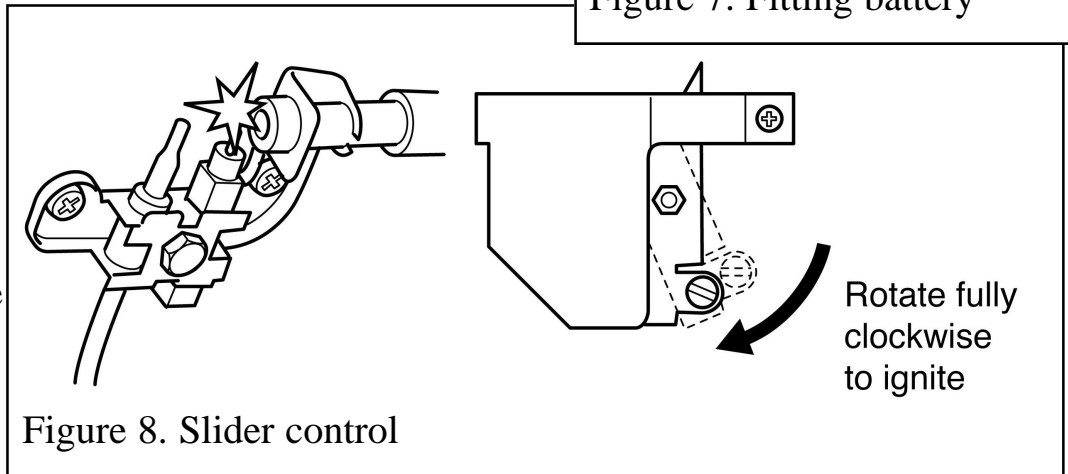

Figure 8. Slider control

7. GAS SUPPLY CONNECTION

A nut and olive are provided for an 8mm pipe inlet connection to the inlet 'T' connector at the bottom front of the appliance. The inlet 'T' connector can be rotated to allow a connection from any direction. The inlet 'T' connector includes a valve for isolating the gas supply and a pressure test point.

The supply pipe must be rigid material. Flexible pipe must not be used.

Concealed supply pipe connection.

If a concealed connection from inside the fireplace is required then, **before the appliance is fitted into the fireplace** it will be necessary to extend the supply line so that it will project through the hole in the back of the convector box and run to the inlet 'T' connector at the front. The pipe run from the supply line up to the rear opening in

INSTALLER GUIDE

the convector box must be kept away from the area which will be taken by the convector box when it is installed. Note that the centre of the appliance inlet 'T' connector is 25mm above the fireplace floor. The inlet 'T' connector should be fitted to the supply pipe at this stage.

8. PREPARING APPLIANCE FOR INSTALLATION

8.1 Appliance preparation

1. Remove any transit tape and packing and inspect for any evidence of mishandling which might affect the performance. Each unit is flame tested before it leaves the factory and as a result there may be slight discolouration around the burner ports.
2. Detach the burner unit from the convector box by removing two screws (See figure 9). Lift the burner unit clear.

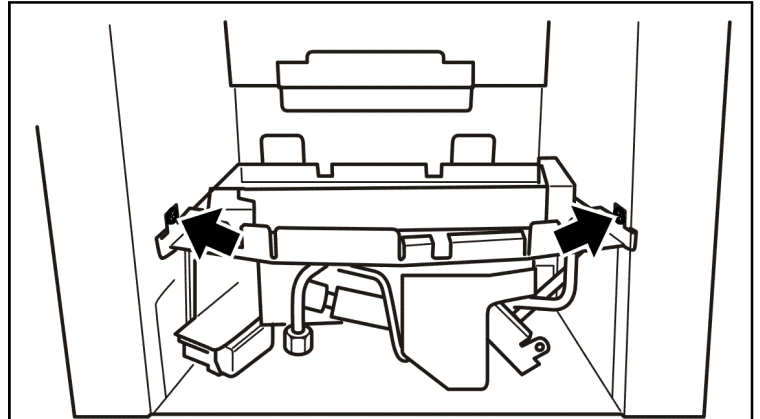

Figure 9. Burner attachment points

IMPORTANT

Before continuing with the installation of this gas fire the aeration setting on the burner must be checked. The aeration is factory set but will require adjustment (See section 17.1).

3. **It is important that the grommet supplied in the loose parts pack is fitted to the hole in the rear of the convector box.**

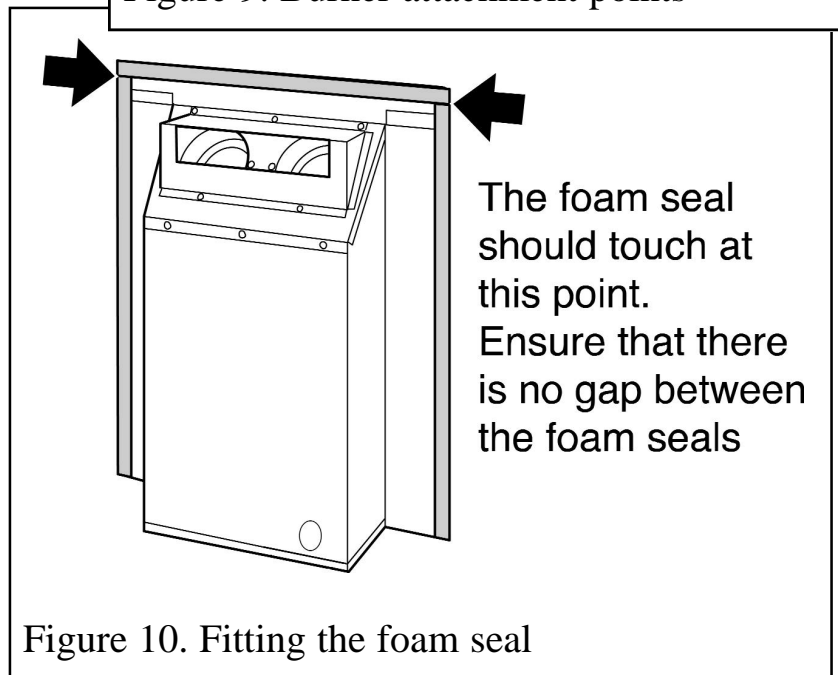

Figure 10. Fitting the foam seal

8.2 Fitting the foam seal.

There is a length of self adhesive foam seal supplied with the fire. This will need to be fitted to the outer rear edges of the side and top flanges of the convector box. Cut the foam seal to the required length. Be careful not to stretch the seal when measuring. Remove the protective backing from the foam seal and fit this to the rear of the convector box flange (See figure 10).

INSTALLER GUIDE

8.3 The flue restrictor.

This appliance is supplied with a flue restrictor for use where the flue draught is excessive. **The restrictor must not be fitted where a precast flue or a 125mm flue liner is used.** For flue liners greater than 125mm and all other installations the restrictor should be fitted. There may however, be certain exceptional circumstances where fitting the restrictor causes the fire to fail the spillage test. In such cases the restrictor will have to be removed. After removal conduct the spillage check again.

Fit the restrictor as shown in figure 11 using the two screws provided.

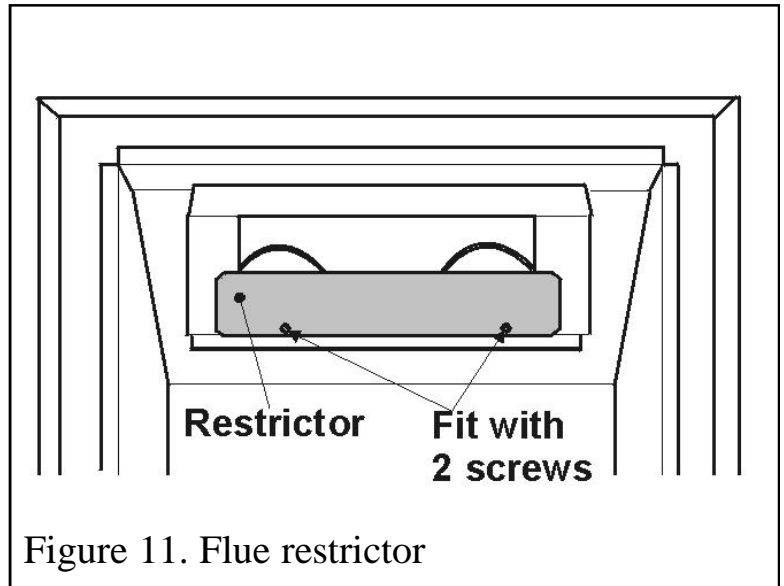

9. CONVECTION BOX INSTALLATION

9.1 Method 1- Front fixing to fireplace surround.

1. Make sure that the fireplace front surround area is sound enough to take the fibreplugs and woodscrews. If necessary, make sound with a suitable cement.
2. Place the convection box centrally in the fireplace in the position in which it is to be permanently installed. If a concealed connection is being used, insert the convection box into the fireplace feeding the supply pipe through the pierced hole in the grommet.
3. Mark the fireplace front surround through the four fixing holes in the side flanges of the hotbox (See figure 12).
4. Remove the hotbox. Drill four holes in the fireplace front surround at the marked positions using a no.12 masonry drill.
5. Insert a fibre plug into each hole.
6. Place the convection box back in position in the fireplace.
7. Fit a woodscrew through each hole in the convection box flanges and tighten to seal the box to the fireplace surround.

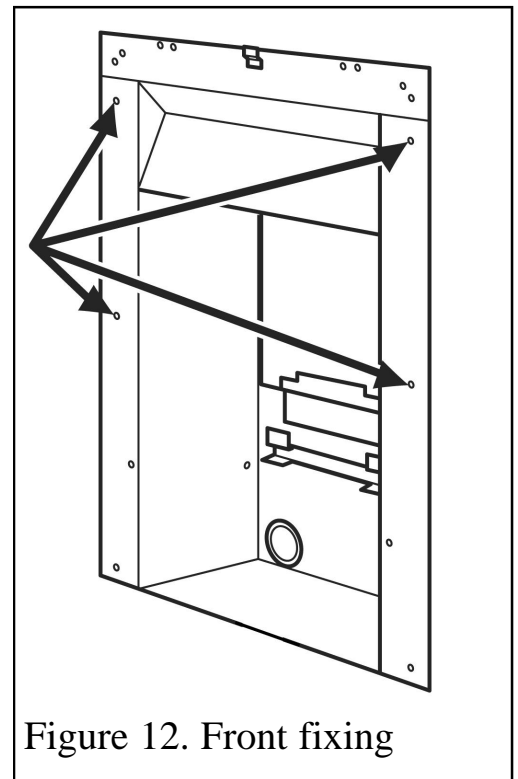

INSTALLER GUIDE

9.2 Method 2 - Cable retention.

1. Make sure that the relevant areas at the fireplace back are sound enough to take the eyebolts. If these areas have deteriorated due to prolonged use they should be made sound with a suitable cement.

2. Drill two holes in the rear wall of the fireplace for the eyebolt plugs. The holes should be drilled within the range of positions shown in figure 13 using a no.12 masonry drill. The holes should be equidistant each side of the centre line of the fireplace to ensure that the appliance finishes centrally in the opening when tension is applied to the cables.

3. Insert a fibre plug into each hole. Use the fibre plugs supplied with this appliance - **Never use plastic plugs instead of the fibre plugs supplied.** Screw the eyebolts into the plugs. Make sure that the bolts are secure.

4. Place the convector box unit close to the fireplace but allow sufficient access into the fireplace opening so that the cables can be threaded through the eyebolts and returned through the back of the convector box. If a concealed connection is being used, insert the convector box into the fireplace feeding the supply pipe through the pierced hole in the rear seal.

5. The rear of the convection box has a slot and hole each side of the outlet opening. Assemble one end of the cable to the top of the fire by passing it through the small round hole and locking by positioning the cable in the adjacent slot (See figure 14). Give the cables a pull so that they grip.

6. Thread the cables through the eyebolts in the rear wall. Return the cables through the holes near the bottom corners of the convection box back panel (See figure 15).

7. Place the convection box fully back into the fireplace opening so that it is sealed against the fireplace front surround.

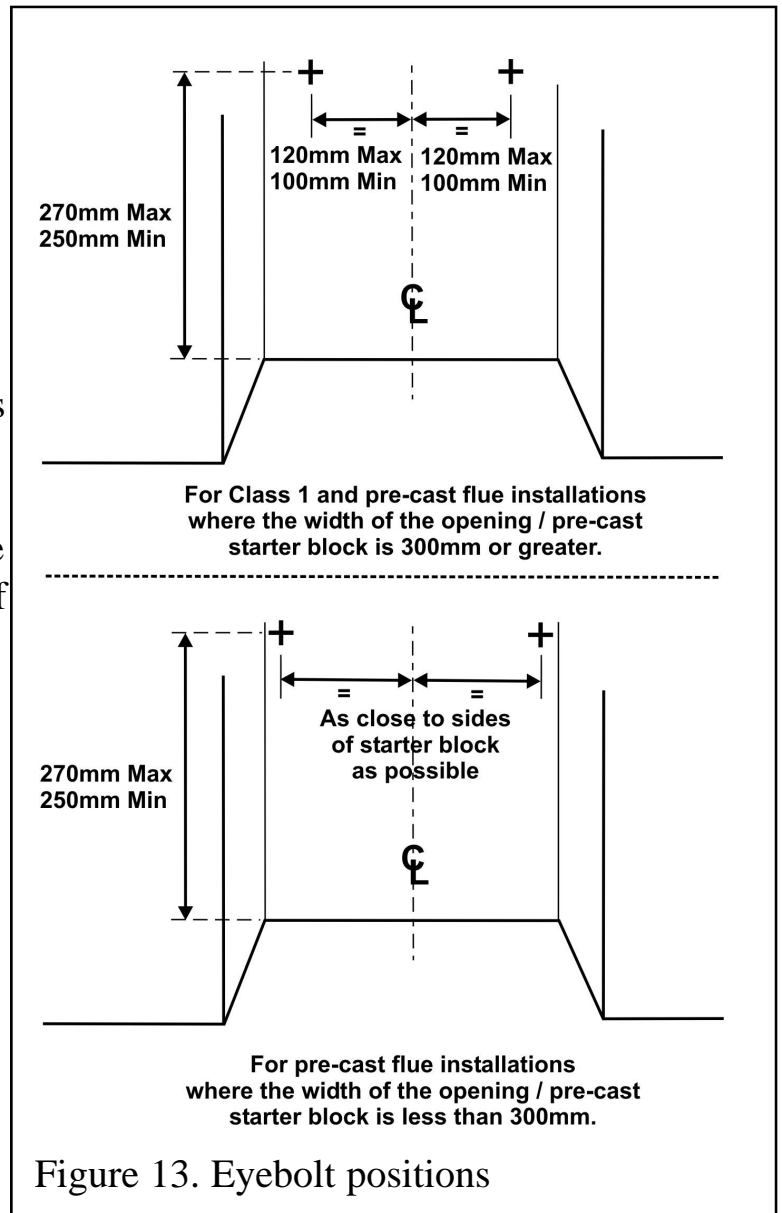
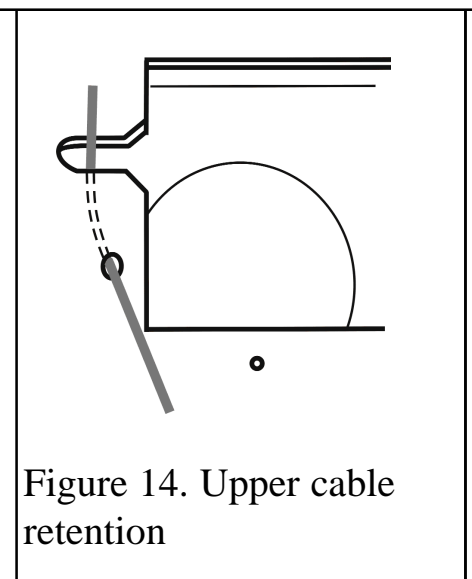

Figure 13. Eyebolt positions



INSTALLER GUIDE

8. Fit a cable retainer over the bottom end of each cable.

9. Pull each cable taut. Push the cable retainers hard up against the back panel. Tighten the screws in the retainers so that they clamp the cables in position.

Apply tension to the cables by turning the hexagonal adjusters by hand (See figure 16).

10. Inspect the installation of the convection box against the fireplace surround. If the convection box is aligned squarely and the sealing is satisfactory, fully tighten the cable retainers.

10. If the convection box is not correctly aligned,

release the tension on the cables by slackening the screws and turning the hexagonal adjusters fully anticlockwise. The convection box should then automatically realign itself. Pull each cable taut again and push the cable retainers back against the back panel. Again, tighten the screws in the retainers and apply tension to the cables by turning the hexagonal adjusters clockwise as far as possible.

11. Push the free length of the cables inside the convection box so that they are available to allow easy removal and refitting of the appliance during subsequent service calls.

9.3 Floor sealing.

Using the floor sealing tape supplied, seal the bottom of the convector box to the fireplace and hearth floor (See figure 17).

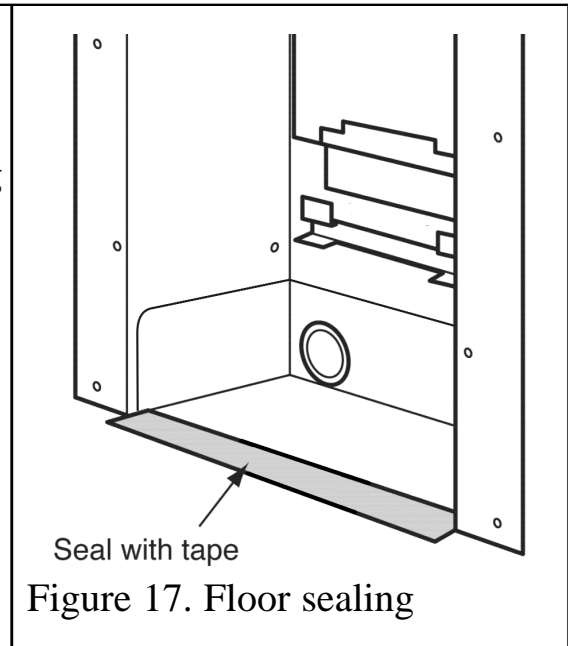
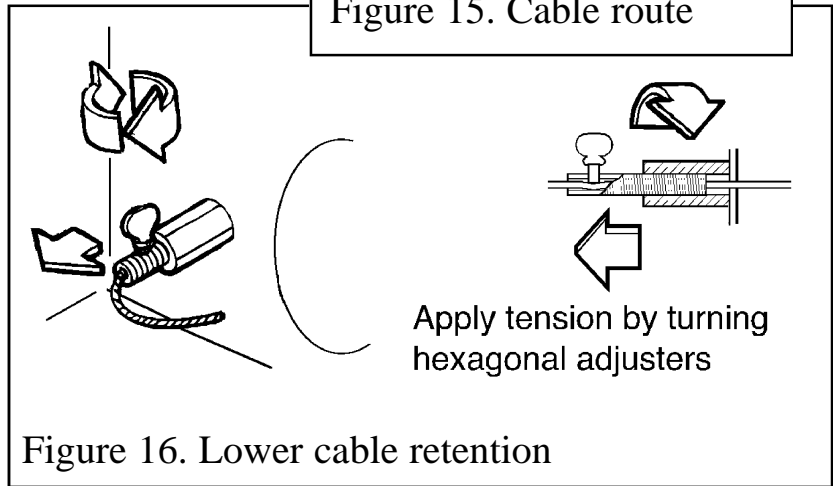
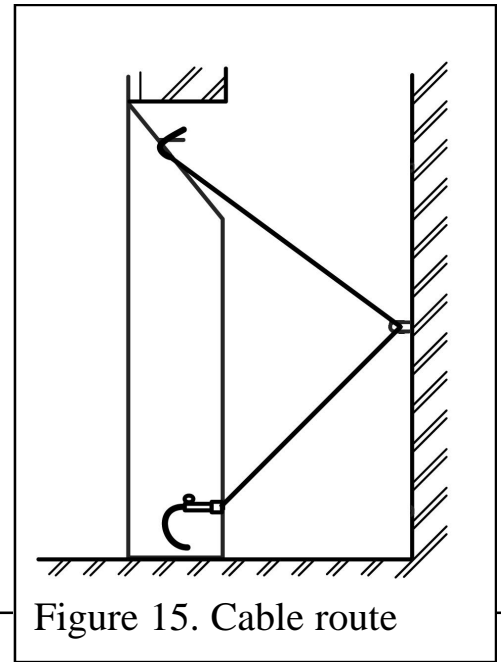

INSTALLER GUIDE

10. BURNER INSTALLATION

10.1 Burner and supply pipe installation.

1. Refit the burner unit to the convection box with two screws.
2. Connect the supply line to the appliance.
3. Pressure check the installation pipework for gas soundness. In the United Kingdom check in accordance with the current edition of BS6891. In the Republic of Ireland refer to the current edition of I.S. 813 “Domestic gas installations”

10.2 Preliminary burner checks.

Some burner operations can be checked at this stage. Checking now will mean that less disassembly will be required if any problems are found. A full check should still be made, however, after final installation

10.2.1 Lighting the burner.

1. If closed, open the isolating valve at the inlet ‘T’ connector.
2. Depress the control pivot plate as far as it will go and hold in this position (See section 6, figure 8). This should close the ignition circuit and (now that the gas is connected) simultaneously open the gas tap allowing the gas to flow to the pilot. Wait a few seconds while the air is purged. The electronically generated sparks should light the pilot. The pilot should then light the main burner at its low setting. There may be a delay of up to four seconds between the pilot lighting and ignition of the gas at the main burner. This is normal and is due to the time required to fill the main burner compartment with sufficient gas for ignition.

10.2.2 Operating the burner.

1. When the burner is operating properly, gradually rotate the control pivot plate in an anticlockwise direction. The burner flames should gradually increase until the control pivot plate is nearly at its highest position. You should feel some resistance when the control pivot plate reaches the maximum burner flame position. Rotating further until the control pivot plate comes to a stop should then turn the burner and pilot off. When the above checks have been completed close the isolating valve on the inlet ‘T’ connector. If the above checks are satisfactory, continue with the installation. If not, check the control and ignition circuitry and components as described in the servicing section of this manual.

10.3 Inlet pressure check.

The appliance is pre-set to give the correct heat input at the inlet pressure shown in section 2 of this manual. No adjustment is necessary.

1. Check the inlet pressure by fitting a pressure gauge at the test point. The test point is on the inlet ‘T’ connector (See figure 18). Check the pressure with the appliance alight and set at maximum output.

INSTALLER GUIDE

2. After checking, turn off the appliance. Remove the pressure gauge and replace the test point sealing screw.

3. Relight the appliance. Turn to the maximum output position and test around the sealing screw for gas soundness with a suitable leak detection fluid.

10.4 Fitting the burner tray trim.

(Not supplied on 'Eternal' model).

1. Fit the burner tray trim over the front rim of the burner tray. Push the trim fully down (See figure 19).

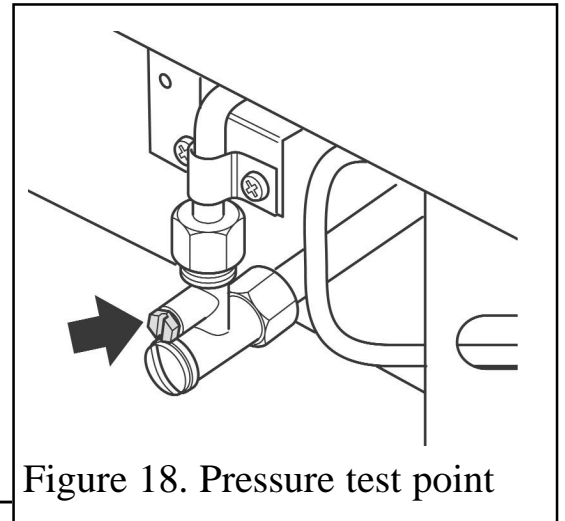

Figure 18. Pressure test point

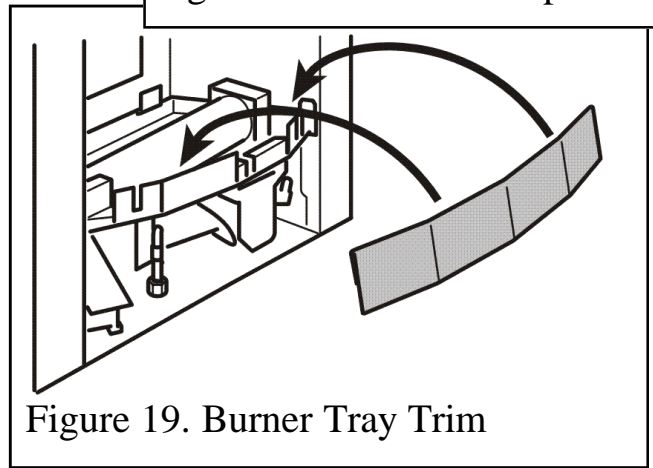

Figure 19. Burner Tray Trim

11. FITTING THE FASCIA

1. Slide the control button upwards as far as it will go. Make sure that the bottom of the linking bar is higher than the bottom of the fascia. Place the fascia against the fireplace front surface so that the two retaining plates at the back of the fascia are directly above the two upper retaining brackets at the top of the convection box. Lower the fascia making sure that the retaining plates locate fully over the brackets on the convection box (See figure 20).

2. Swing the bottom control linking bar towards the centre of the fire to clear the right side of the fascia. Slide the fascia sideways, if necessary, to align the bottom fixing holes with those in the convection box (This will not be possible on the Dream). Fix the bottom of the fascia unit to the convection box with two screws (See figure 21).

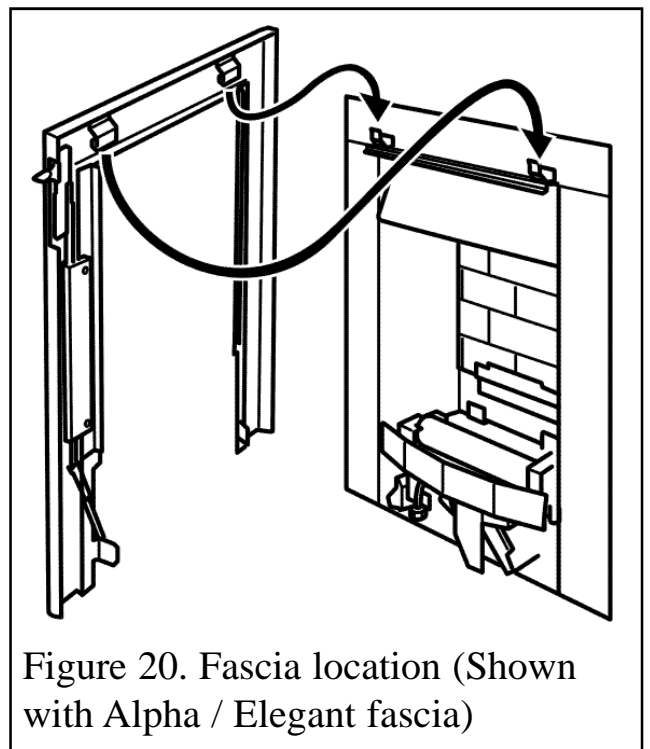

Figure 20. Fascia location (Shown with Alpha / Elegant fascia)

INSTALLER GUIDE

3. Connect the control linkage to the control pivot plate using the shouldered screw and using a screwdriver (Not finger tight only) (See figure 22).

Dream and Eternal models only.

1. Supplied with the fire is a self adhesive control position label. Peel the backing from the label and place as in figure 23.

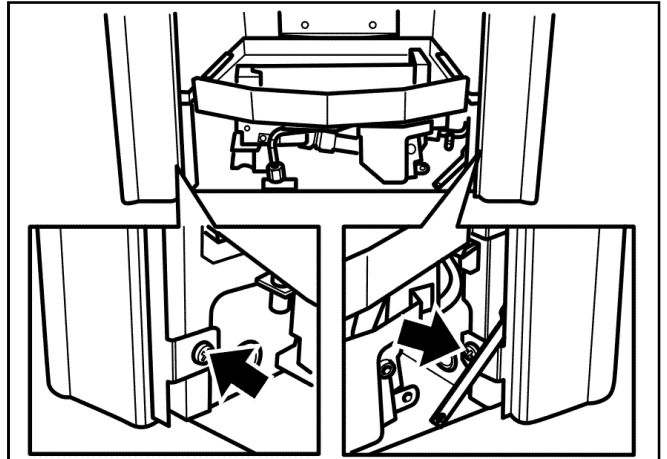

Figure 21. Fascia bottom location.

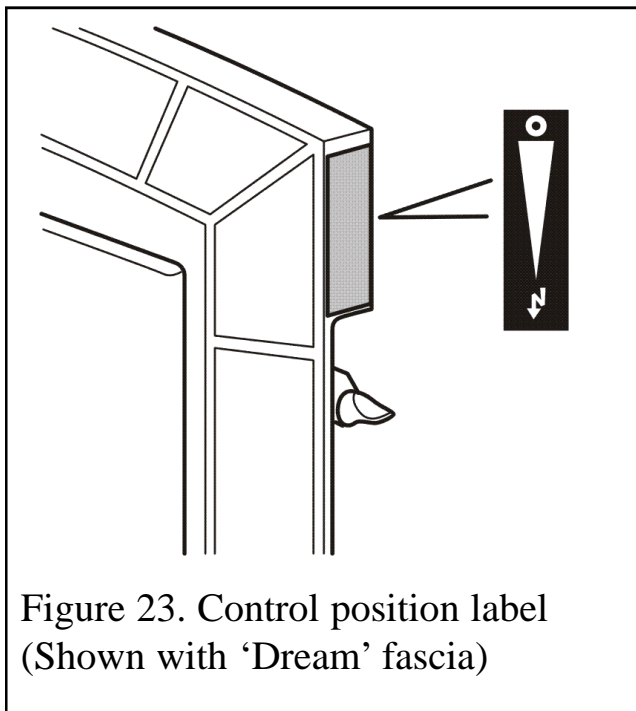

Figure 23. Control position label (Shown with 'Dream' fascia)

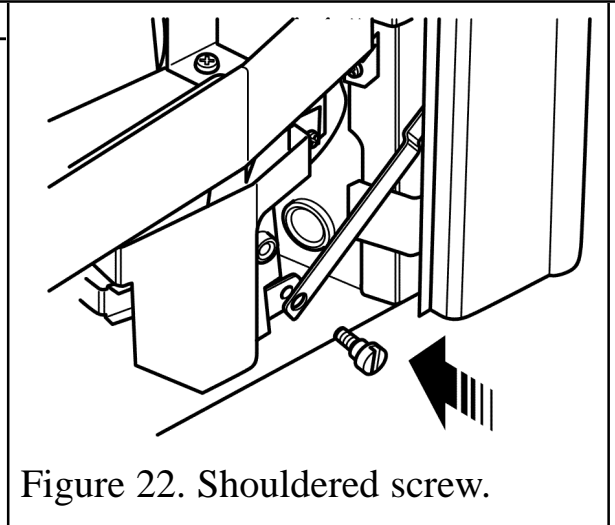

Figure 22. Shouldered screw.

12. FITTING THE CERAMIC FUEL EFFECT

The installer and owner guide for the ceramic fuel effect is supplied with the ceramic fuel effect. It is important that the fitting guide for the ceramic fuel effect be placed inside or attached to this guide and handed to the customer following completion of the 'Final review' section.

13. FIREFRONT CASTING INSTALLATION

13.1 Fitting the Alpha, Eternal and Elegant firefront casting.

1. Fit the fire front casting to the fascia. Locate the two screw heads at the rear top corners of the casting through the keyhole slots at the inner sides of the fascia. If the screw heads do not project enough or project too far, the screws can be adjusted. Lower

INSTALLER GUIDE

the casting so that it rests on the hearth (See figure 24).

2. Place the bottom front cover casting in position below the fire front casting.

13.2 Fitting the Dream firefront casting.

1. Place the firefront casting centrally on the hearth in front of the fascia.

2. Place the bottom front cover casting in position below the firefront casting.

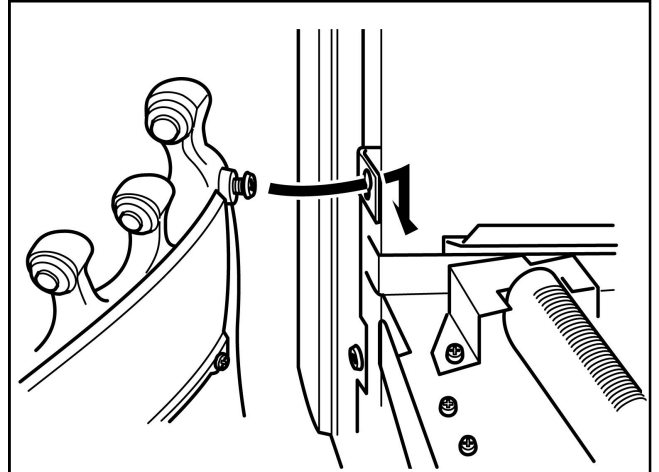

Figure 24. Firefront casting location (Shown with Alpha / Elegant casting)

14. FULL OPERATING CHECKS

14.1 Recheck the control settings.

The control position markings on the fascia are shown in figure 25.

Please note:

- When first turned on from cold, the flames will appear predominantly blue.
- When operating the fire for the first time, some vapours may be given off which could set off smoke alarms in the vicinity. These vapours are quite normal with new appliances. They are totally harmless and will disappear after a few hours use.

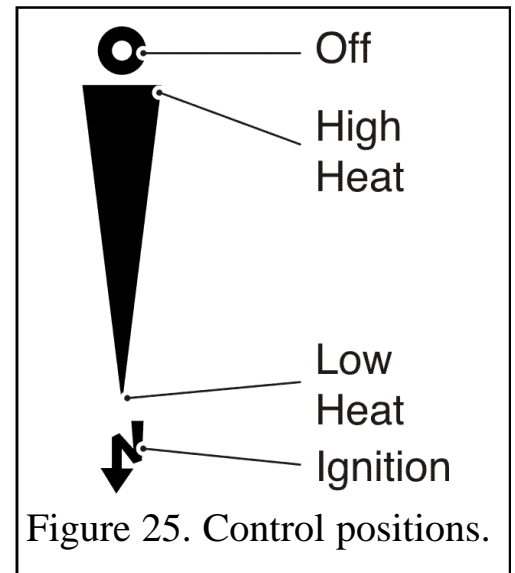



Figure 25. Control positions.

14.2 Lighting the burner.

1. Make sure the slider button is at the 'OFF' position (At topmost position marked "O" on the fascia).

2. Open the isolating valve on the inlet 'T' connector.

3. Slide the button to the bottom (ignition) position marked . Retain in this position to ignite the pilot. The burner should ignite at its lowest setting within 4 seconds of the pilot igniting. Keep at this position for a further 10 seconds to allow the pilot flame to stabilise.

4. Release the button. The button should automatically spring up to the low heat position. If the flames go out at this stage or when checking the rest of the setting positions, try the full lighting sequence again. If the flames fail after two attempts, investigate the pilot unit.

INSTALLER GUIDE

14.3 Operating the burner.

1. Gradually slide the button up to increase the burner setting. The burner should be at its maximum setting at the high heat position shown in figure 25. You should feel a check to the button movement at this position.
2. Slide the control button up past the high heat position to the off ("O") position at the top of the slide slot. Both pilot and main burner should go out.
While cooling the ceramic fuel effect pieces may make some crackling noises. This is quite normal.
3. Check that the control linkage bar does not interfere with the appliance cable retention nuts or wires.

15. SPILLAGE AND FLAME SUPERVISION CHECKS

15.1 Check for spillage.

A spillage check must be made before leaving the installed appliance with the customer. Make this with all the ceramic fuel effect pieces, fascia and firefront in position.

1. Close all doors and windows in the room containing the appliance.
2. Light the appliance and set the slide control to the maximum burning position.
3. Leave the appliance on for five minutes.
4. Place the smoke match into the appliance canopy (See figure 26).
5. The installation is satisfactory if the smoke is drawn into the appliance. If the smoke is not drawn into the appliance, leave the appliance alight at the maximum setting for a further ten minutes and then repeat the test. If smoke is still not drawn into the appliance, inspect the sealing to the fireplace surround. If the sealing is satisfactory but the appliance is installed with the flue restrictor (See section 8.3), remove the restrictor, reseal the appliance and retest. If smoke is still not drawn into the appliance, disconnect the appliance and seek expert advice.

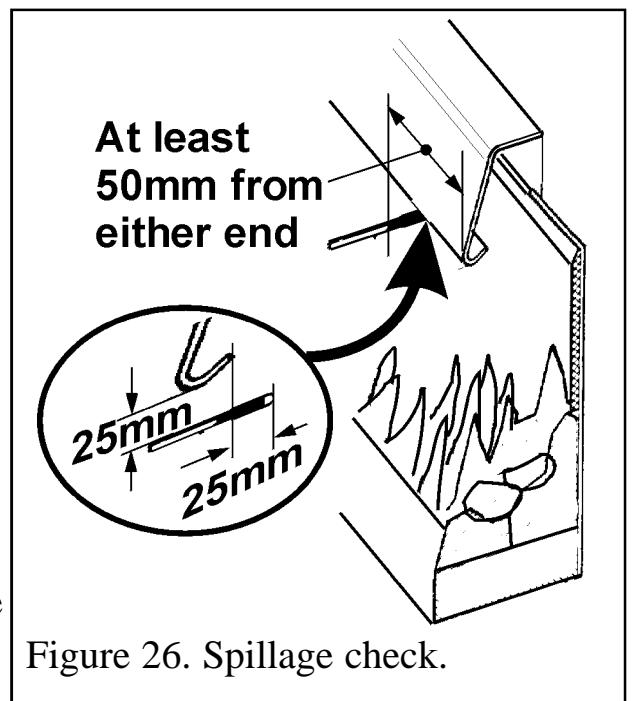

6. If the above test is satisfactory, open all internal connecting doors, hatches, etc., in the room. Keep all doors and windows that open to the outside of the building closed. Recheck for spillage as above. If an extractor fan is installed in the same room as the appliance or a connecting room, check that spillage does not occur with the fan operating and all doors and other openings between the fan and the appliance open. If

INSTALLER GUIDE

the smoke is drawn into the appliance, continue with the installation. **If the test is not satisfactory, disconnect the appliance and advise the customer of the cause of failure.**

15.2 Flame supervision and spillage monitoring system.

This pilot unit includes a system that will automatically shut off the gas supply if the pilot flame goes out or if there is insufficient oxygen due to spillage or poor ventilation. Check that the system operates properly as follows;

1. Light the appliance. Set the slide control to the maximum burning position and leave for one minute.

2. Set the control to the 'Low' burning position. Isolate the gas supply at the inlet 'T' connector. The pilot and main burner will go out. **Note the time when the pilot goes out.** Listen for a snap sound at the gas tap. **Note the time when the sound is heard.** This sound is caused by an electromagnetic valve shutting off the gas supply through the tap. The valve is located in the body of the tap. The valve should operate **within 60 seconds of the pilot going out.** If the valve does not operate within this time limit do not allow the appliance to be used until the fault has been corrected.

This monitoring system must not be adjusted, bypassed or put out of operation. This monitoring system, or any of its parts, must only be exchanged using authorised parts.

3. Open the isolating valve on the inlet 'T' connector. Screw on the end cap and test for leaks.

4. Set the slider to the "OFF" position.

16. FINAL REVIEW

1. Visually inspect the appliance. Clean off any marks incurred during installation.

2. Advise the customer how to operate the fire.

3. Explain to the customer that the appliance has a flame failure and spillage monitoring system. Point out the explanation of this system shown in the owner guide.

Advise that if the fire goes out for any reason, wait at least three minutes before relighting. Stress that if the monitoring system repeatedly shuts off the fire, the appliance should be switched off and a specialist should be consulted. Point out that the lighting instruction details are on a metal plate attached at the bottom of the appliance.

4. Advise that the fire may give off a slight odour while new. This is quite normal and it will disappear after a short period of use.

5. Advise that any cleaning must only be carried out when the fire is off and cold.

6. Advise the customer that they should read the owner guide before operating the fire and always follow the advice in the section headed "Cleaning your fire".

7. Advise the customer that the appliance will operate to its maximum potential if the flue is primed during the first 20 – 30 minutes of use. To do this, simply set the control

INSTALLER GUIDE

to its highest setting. This will also burn off any carbon deposits that may have formed during previous use.

If using the appliance for long periods it is beneficial to change between settings. This will also help to remove any carbon deposits that may form during use.

8. Recommend that the appliance should be serviced and the chimney inspected by a competent person (In the UK a CORGI registered person) at least annually.

If the appliance is in premises in the United Kingdom occupied by a tenant, point out that by law a landlord must have any gas appliance, flue and pipework which is situated in a tenant's premises checked for safety at least every 12 months.

9. Advise the customer that the castings, fascia, firebox and ceramic pieces can be cleaned as described in the owner guide and that the loose ceramic fuel effect pieces must be replaced as described in those instructions.

Stress that no extra ceramic fuel effect pieces must be added over and above those supplied with the appliance and that any replacements must only be the authorised spares. Warn that ignoring this advice could cause incomplete clearance of the products of combustion with consequent health hazards.

10. Inform the customer that the Serial number for the appliance is located on plate, located behind the lower front casting and underneath the burner.

11. Hand the literature pack with this guide to the customer.

17. SERVICING & PARTS REPLACEMENT

Always turn off the gas supply and allow to cool completely before commencing any servicing (The appliance inlet "T" connector incorporates an isolating valve). It is recommended that, at least once a year, the appliance is disconnected and the fireplace opening checked and cleared of any debris.

This product uses fuel effect pieces and a burner compartment rear wall containing Refractory Ceramic Fibres (RCF), which are man-made vitreous silicate fibres. Excessive exposure to these materials may cause irritation to eyes, skin and respiratory tract. Consequently, it is important to take care when handling these articles to ensure that the release of dust is kept to a minimum. To ensure that the release of fibres from these RCF articles is kept to a minimum, during installation and servicing we recommend that you use a HEPA filtered vacuum to remove any dust and soot accumulated in and around the fire before and after working on the fire. When replacing these articles we recommend that the replaced items are not broken up, but are sealed within a heavy duty polythene bag, clearly labelled as RCF waste. This is not classified as "hazardous waste" and may be disposed of at a tipping site licensed for the disposal of industrial waste. Protective clothing is not required when handling these articles, but we recommend you follow the normal hygiene rules of not smoking, eating or drinking in the work area and always wash your hands before eating or drinking.

INSTALLER GUIDE

- Check that the appliance is clean and that soot or debris is not blocking the gaps between the ceramic fuel effect pieces causing an imperfect flame.
- Check that soot or debris is not impairing the electrode spark or pilot burner.
- Check that soot or debris is not blocking any of the holes in the main burner.
- After servicing, make sure that the ceramic rear wall and ceramic fuel effect pieces are replaced correctly as described in the installer and owner guide supplied with the ceramic fuel effect. The installer and owner guide supplied with the ceramic fuel effect should be placed inside or attached to this guide.
- **Always test for gas soundness and spillage after servicing the appliance.**

17.1 Checking the aeration setting of the burner.

1. The aeration shutter is factory set and **will** require adjustment. **It is important to ensure that the aeration setting is correct (See figure 27).**

2. To adjust the aeration setting, loosen the two aeration shutter screws, slide the aeration shutter to the position shown in figure 27 and tighten the fixing screws.

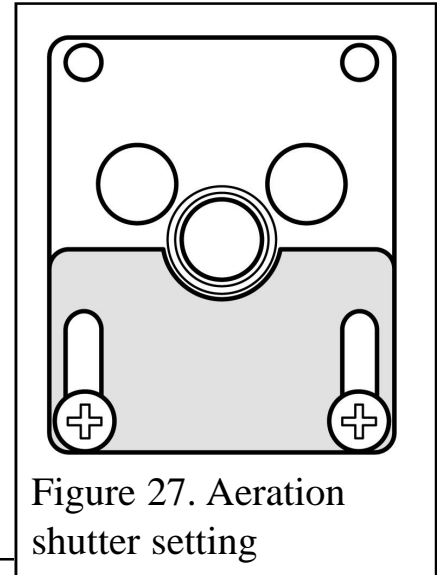

Figure 27. Aeration shutter setting

17.2 To remove the ignition microswitch.

(See figures 28 & 29).

The ignition microswitch is stamped V4NT9C4YC

1. Remove the firefront casting and the front cover casting.

2. Detach the microswitch cover by removing one screw and pulling clear of the location lug (See figure 27).

3. Disconnect the leads from the ignition microswitch (The lower of the two microswitches - See figure 28).

4. Detach the microswitch and insulation pad by removing two screws.

5. Replace in the reverse order.

6. Check that the microswitch operates correctly by fully closing it and observing that there are sparks at the pilot electrode.

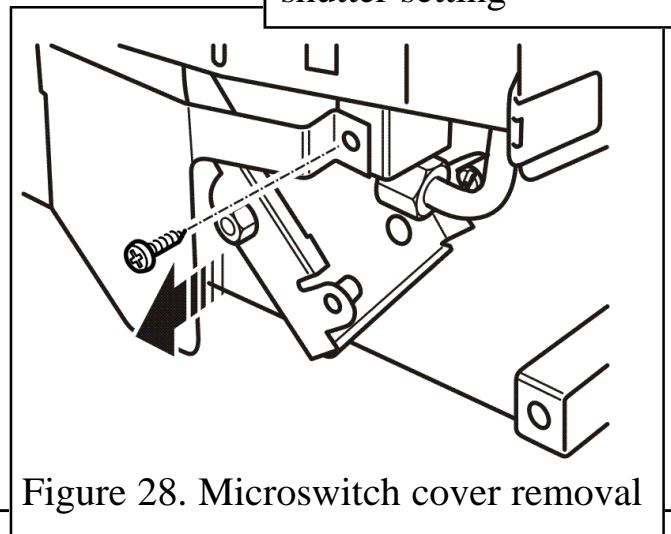

Figure 28. Microswitch cover removal

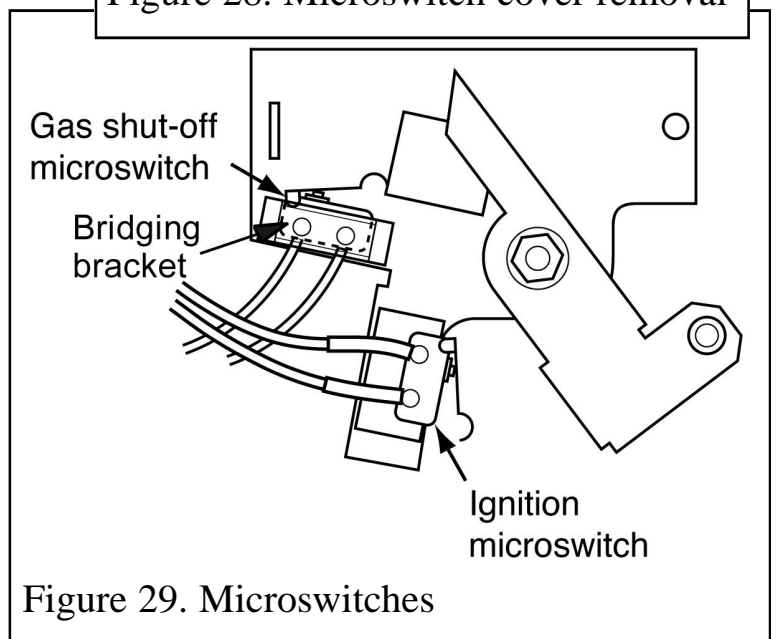

Figure 29. Microswitches

INSTALLER GUIDE

17.3 To remove the gas shut-off microswitch

(See figures 28, 29 & 30).

The gas shut-off microswitch is stamped V4NT9C2YCGPX or V4NT9C2YCAUX.

1. Remove the firefront casting and the front cover casting.
2. Detach the microswitch cover by removing one screw and pulling clear of the location lug (See figure 28).
3. Loosen the thermocouple nut to free the microswitch leads and pull the leads clear of the thermocouple interrupter block (See figure 30).
4. Detach the bridging bracket, microswitch assembly by removing two screws (See figure 29).
5. Replace in the reverse order. When refitting the leads to the interrupter block, make sure that they are secured firmly to give a good electrical contact.

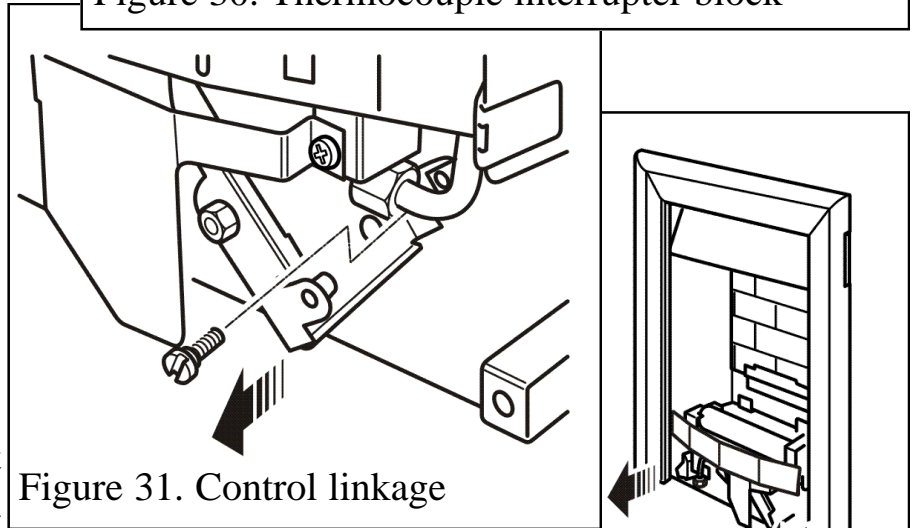
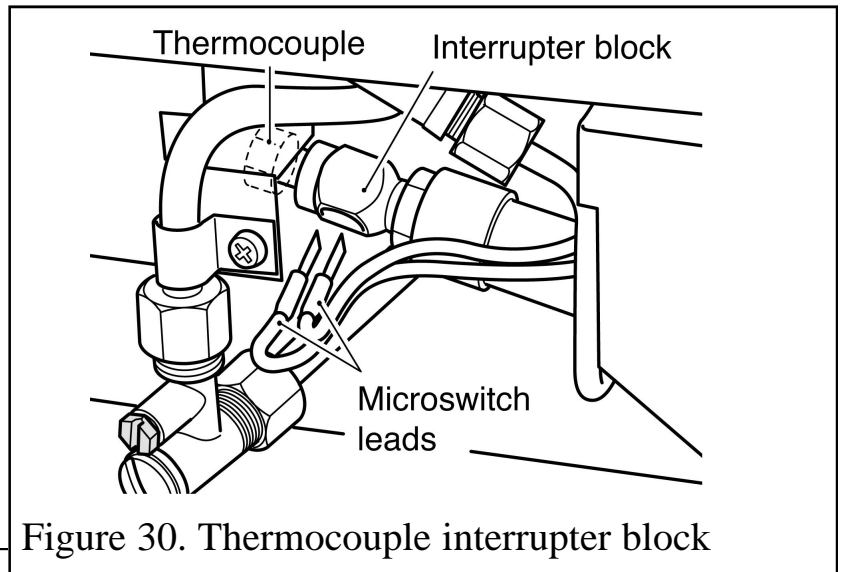

17.4 To remove the fascia.

1. Remove the firefront casting and the front cover casting.
2. Detach the control-linking bar from the control pivot bracket by removing the knurled screw, which joins the control linking bar to the control pivot unit (See figure 31).
3. Remove the two screws securing the bottom of the fascia to the sides of the convection box.
4. **Make sure that the control linking bar has been detached (See point 2).** Carefully lift the fascia upward to clear the upper retaining brackets on the convection box (See figure 32). Pull the fascia clear and place carefully aside.
5. Refit in the reverse order. Make sure that the fascia is properly located over the upper retaining brackets. See section 11 of this guide for detailed fitting instructions.

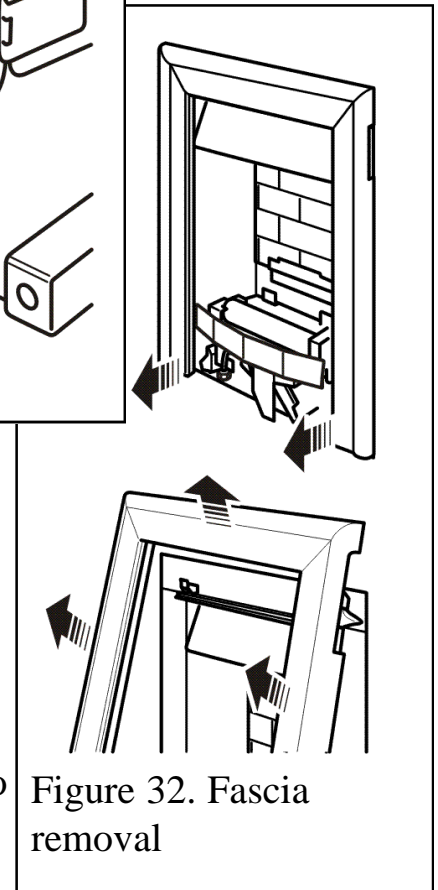

INSTALLER GUIDE

17.5 To replace the control slide button.

1. Remove the fascia (See section 17.4).
2. Detach the slider control from the fascia by removing two screws (See figure 33).
3. Detach the control slide button from the extension bracket by removing two screws (See figure 34).
4. Replace in the reverse order.

17.6 To remove the burner unit.

1. Remove the fascia (See section 17.4).
2. Remove the loose ceramic fuel effect
3. Support the inlet 'T' connector to avoid straining the pipework and disconnect the appliance from the inlet 'T' connector.
4. Detach the burner unit from the convection box by removing two screws (See figure 35).
5. Replace in the reverse order.

17.7 To remove the electronic ignition generator.

1. Remove the burner unit (See section 17.6)
2. Remove the battery.
3. Remove the spark lead and microswitch leads remembering to make note of their positions.
5. Unscrew the two fixing screws that attach the generator unit to the support bracket. The igniter generator can now be removed (See figure 36)
8. Replace the generator
9. Refit in the reverse order.

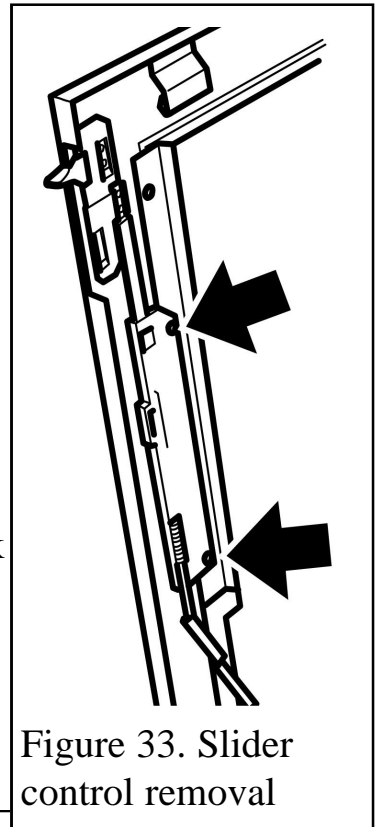

Figure 33. Slider control removal

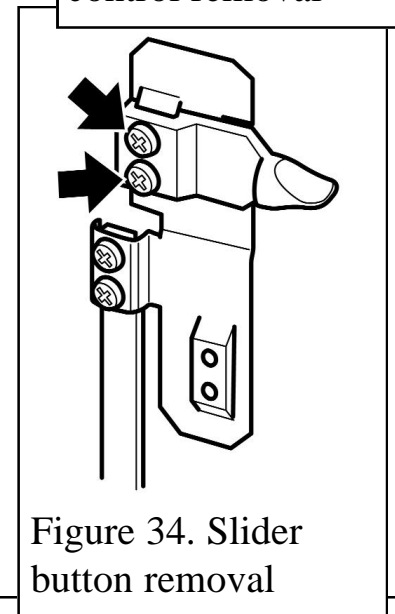

Figure 34. Slider button removal

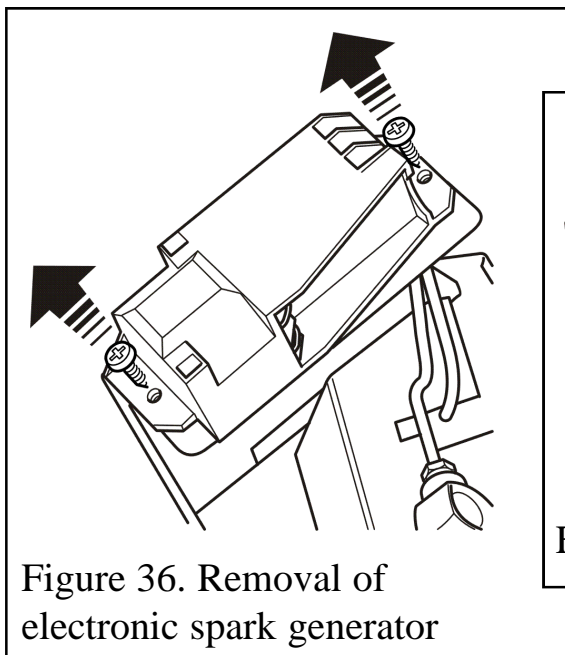

Figure 36. Removal of electronic spark generator

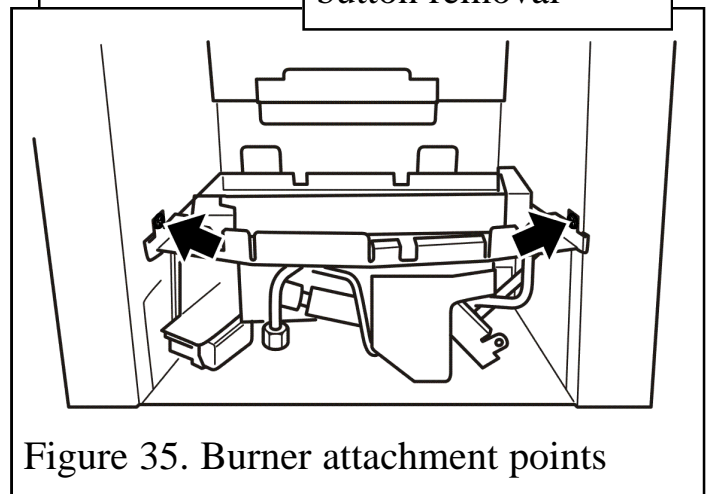

Figure 35. Burner attachment points

INSTALLER GUIDE

17.8 To remove the thermocouple interrupter block.

(See figure 37).

1. Remove the burner unit (See section 17.6).
2. Detach the thermocouple from the interrupter block by unscrewing the thermocouple nut.
3. Detach the two microswitch leads from the interrupter block.
4. Remove the interrupter block by unscrewing from the gas shut-off tap.
5. Refit in the reverse order. If the microswitch leads cannot be easily attached to the interrupter block when it is fully tightened to the gas shut-off tap, slacken it and rotate to allow the leads to be fitted. Retighten making sure that the leads remain in place in the interrupter block. Fit and tighten the thermocouple nut making sure that the leads are secured in the interrupter block to give a good electrical contact.

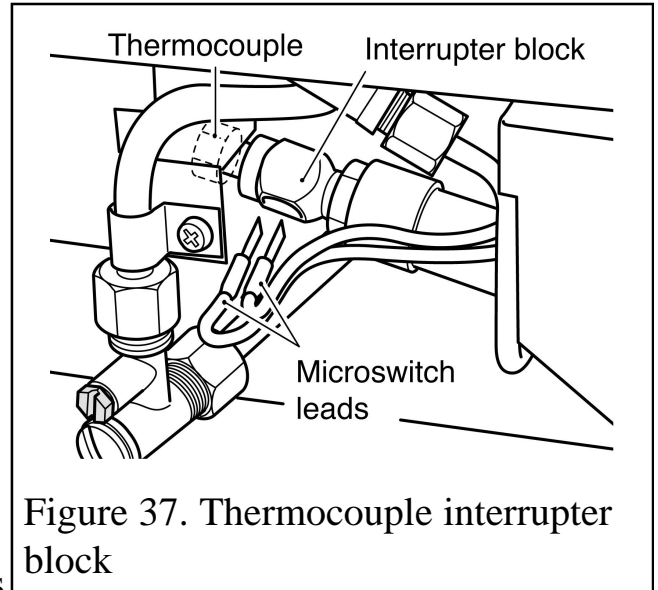

Figure 37. Thermocouple interrupter block

17.9 To remove the pilot unit.

1. Remove the burner unit (See section 17.6).
2. Detach the pilot pipe from the pilot unit.
3. Detach the thermocouple from the interrupter block by unscrewing the thermocouple nut.
4. Detach the electrode lead from the underside of the electrode tab.

6. Remove the two screws securing the pilot unit (See figure 38).
7. Refit in the reverse order.

Note:

1. The pilot unit is an atmosphere sensing device. It must be replaced as a whole assembly. Its individual components are not separately replaceable.
2. When the thermocouple is removed from the interrupter block, the microswitch lead terminals in the interrupter block will be loose. Make sure that they are properly secured to give a good electrical contact when retightening the thermocouple nut.

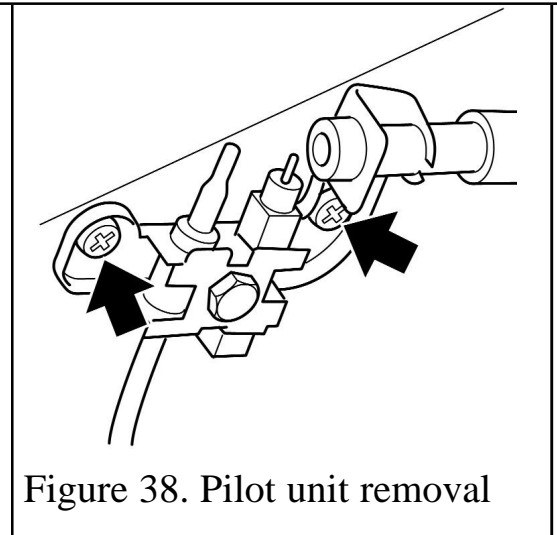

Figure 38. Pilot unit removal

17.10 To remove the shut-off tap.

(See figure 39).

1. Remove the burner unit (See section 17.6).
2. If lying the burner on its back, ensure that the work surface is suitably protected. This will avoid damage to the work surface. Turn the burner unit upside down. Detach the thermocouple and interrupter block from the tap (See section 17.8 paragraphs 2 - 4).

INSTALLER GUIDE

3. Detach the pilot pipe from the tap.
4. Detach the inlet pipe.
5. Remove the hexagonal nut securing the tap to the mounting bracket.
6. Detach the elbow by unfastening the hexagonal nut connecting it to the flow rate controller. Lift the tap (complete with elbow) clear.
7. Loosen the hexagonal locknut securing the elbow to the tap. Remove the elbow by rotating it.
8. If fitting a new tap, remove the hexagonal nut at the mounting bracket end of the old tap and fit to the replacement tap. Refit in the reverse order. When refitting, make sure that the tap spindle is in the correct relationship relative to the control pivot bracket. Rotate the pivot bracket fully clockwise. The tap spindle should “bottom out” (i.e. the tap should be fully open) after the pivot bracket has actuated the ignition microswitch but before it has pushed the microswitch leaf against the microswitch body.

When refitting the thermocouple and interrupter block, make sure that the microswitch wires are properly secured to give a good electrical contact.

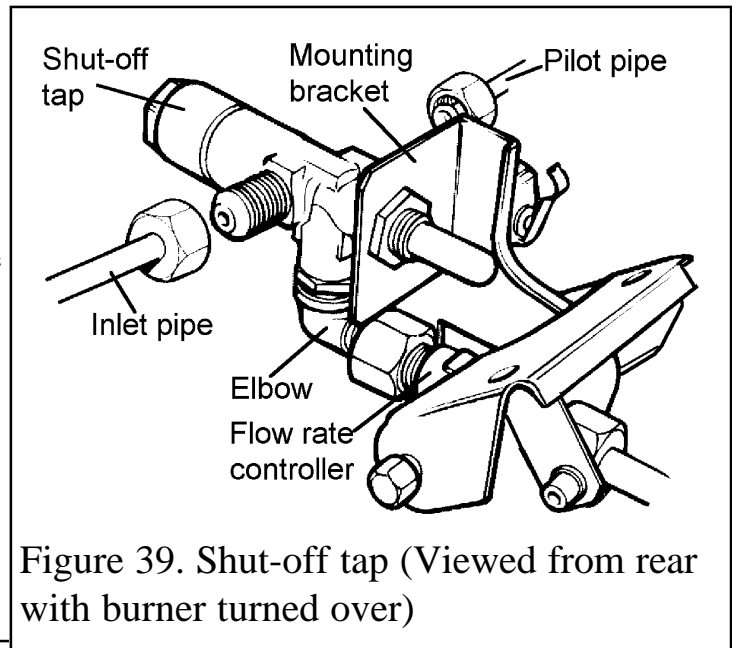

Figure 39. Shut-off tap (Viewed from rear with burner turned over)

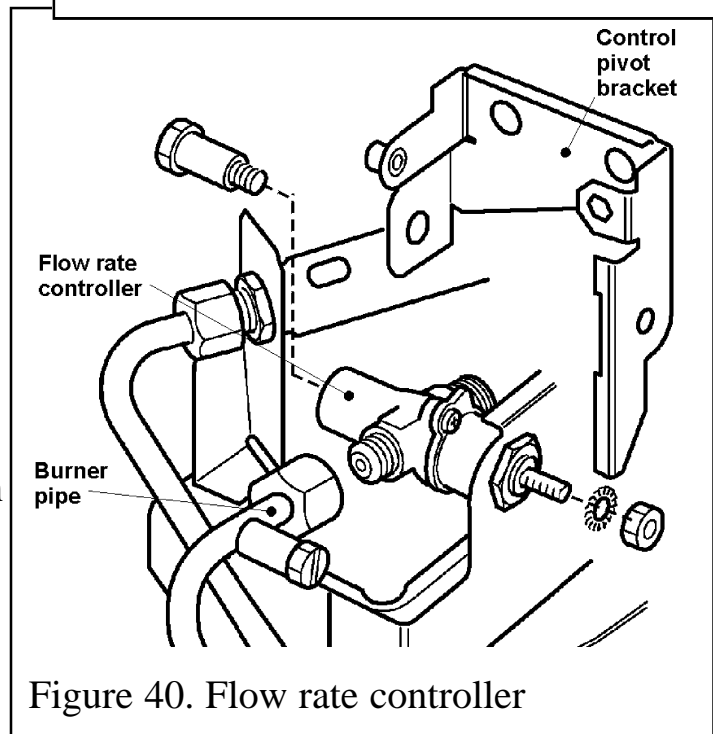

Figure 40. Flow rate controller

17.11 To remove the gas flow rate controller.

(See figure 40).

1. Remove the burner unit (See section 17.6).
2. If lying the burner on its back, ensure that the work surface is suitably protected. This will avoid damage to the work surface.
3. Detach the microswitch cover (See section 17.2 paragraph 2).
4. Detach the shut-off tap as detailed in section 17.10 paragraphs 2-6.
5. Detach the burner pipe from the controller. Support the controller while detaching to prevent excessive strain.
6. Remove the nut and washer securing the control pivot bracket to the controller at the front. Support the pivot bracket while removing the nut to prevent possible damage to

INSTALLER GUIDE

the microswitch.

7. Remove the hexagonal bolt securing the control pivot bracket to the controller at the rear.
8. Detach the control pivot bracket.
9. Remove the hexagonal nut securing the controller to the front mounting bracket and remove the flow rate controller.
10. Refit in the reverse order.

17.12 To replace the burner.

(See figure 41).

1. Remove the burner unit (See section 17.6).
2. Support the elbow injector and unscrew the injector nut.
3. Remove the two screws from the burner clamping plate (See figure 41)
4. Lift the right hand side of the burner, slide it to the right and lift clear.
5. Refit in reverse order.

17.13 To remove the main burner injector.

(See figure 42).

1. Remove the burner (See section 17.12).
2. Remove the burner clamping screw (See figure 42)
3. Unscrew the injector from the burner
4. Refit in the reverse order.

17.14 To remove the appliance from the fireplace.

1. Remove the burner unit (See section 17.6).
2. If the fire retention is as method 1 (See section 9.1 of installation instructions), remove the fascia (See section 17.4) and then remove the fixing screws. If the fire retention is as method 2 (See section 9.2 of installation instructions), slacken the hexagonal adjusters on the cable retainers and unscrew the thumbscrews to release the cables.

3. Refit as described in the relevant installation sections. Make sure gas soundness, sealing, spillage test and performance are satisfactory.

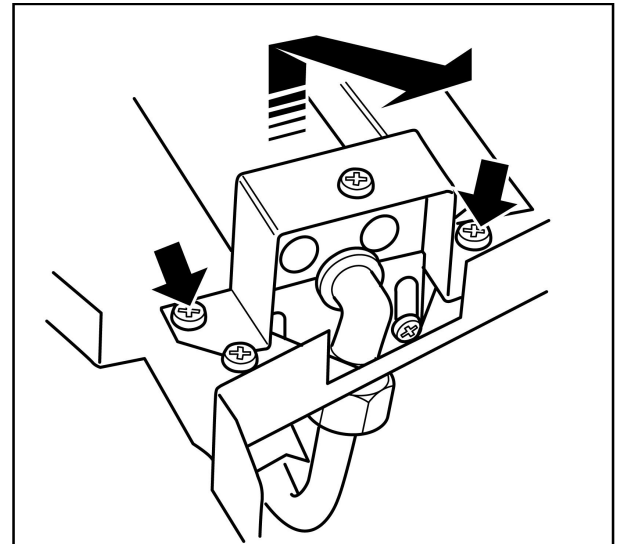

Figure 41. Removal of burner

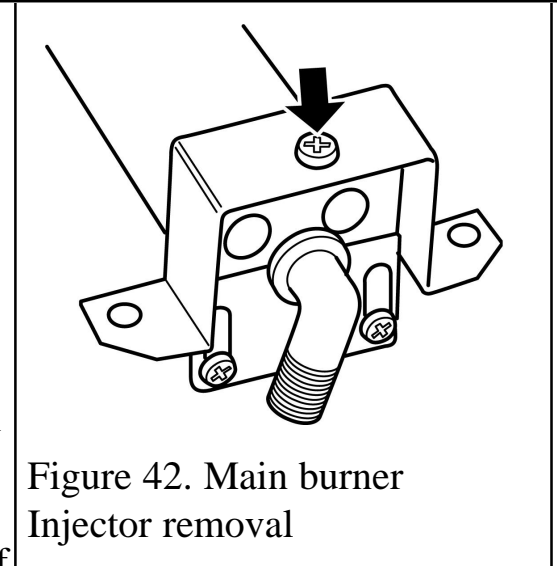

Figure 42. Main burner
Injector removal