

BAXI FIRES DIVISION

INSTALLER GUIDE

Model 759

OPEN DECORATIVE GAS FIRE

Fitted with



ARC fascia

(GC No. 32-032-68)

**THIS APPLIANCE IS FOR USE WITH NATURAL GAS (G20).
THIS APPLIANCE IS SUITABLE ONLY FOR INSTALLATION IN THE UNITED
KINGDOM (GB) AND THE REPUBLIC OF IRELAND (IE).**

We trust that this guide gives sufficient details to enable this appliance to be installed and maintained satisfactorily. However, if further information is required, our **Baxi Fires Division Technical Helpline** will be pleased to help.

Please telephone **08706 061 065** (National call rates apply in the United Kingdom)

In the Republic of Ireland telephone **0044 8706 061 065**

BAXI ● VALOR ● WONDERFIRE

INSTALLER: Please leave this guide with the owner

INSTALLER GUIDE

Safety First.

Baxi Fires Division fires are CE Approved and designed to meet the appropriate British Standards and Safety Marks.



Quality and Excellence.

At the heart of every Baxi Fires Division fire.

All Baxi Fires Division fires are manufactured to the highest standards of quality and excellence and are manufactured under a BS EN ISO 9001 quality system accepted by the British Standards Institute.



The Highest Standards

Baxi Fires Division is a member of the Society of British Gas Industries which works to ensure high standards of safety, quality and performance.



Careful Installation

Baxi Fires Division is a CORGI registered company. All our gas fires must be installed by a competent CORGI Registered Installer in accordance with our Installer Guide and should not be fitted directly on to a carpet or floor of combustible material.

B A X I F I R E S D I V I S I O N

Baxi Fires Division, Erdington, Birmingham B24 9QP

www.firesandstoves.co.uk

Because our policy is one of constant development and improvement, details may vary slightly from those given in this publication

INSTALLER GUIDE

CONTENTS

<u>Section</u>	<u>Page</u>
1. SAFETY	3
2. APPLIANCE DATA	4
3. GENERAL INSTALLATION REQUIREMENTS	5
4. PACK CONTENTS	10
5. INSTALLATION OF APPLIANCE	10
6. BURNER AND SUPPLY PIPE INSTALLATION	13
7. FITTING THE CERAMIC FUEL EFFECT	14
8. FULL OPERATING CHECKS	14
9. SERVICING & PARTS REPLACEMENT	16
9.1 To remove the complete burner unit.	16
9.2 To remove the pilot unit.	17
9.3 To remove the gas valve.	17
9.4 To remove the piezo generator.	18
9.5 To grease the control tap.	18
9.6 To replace the burner.	18
9.7 To remove the main burner injector.	19

1. SAFETY

Installer

Before continuing any further with the installation of this appliance please read the following guide to manual handling:

- The lifting weight of this appliance is as below:

Heat engine (kg)

2.42

Casting (kg)

5.45

- One person should be sufficient to lift the fire. If for any reason this weight is considered too heavy then obtain assistance.
- When lifting always keep your back straight. Bend your legs and not your back.
- Avoid twisting at the waist. It is better to reposition your feet.
- Avoid upper body/top heavy bending. Do not lean forward or sideways whilst handling the fire.
- Always grip with the palm of the hand. Do not use the tips of fingers for support.
- Always keep the fire as close to the body as possible. This will minimise the cantilever action.
- Use gloves to provide additional grip.
- Always use assistance if required.

INSTALLER GUIDE

2. APPLIANCE DATA

This product uses fuel effect pieces containing Refractory Ceramic Fibres (RCF), which are man-made vitreous silicate fibres. Excessive exposure to these materials may cause irritation to eyes, skin and respiratory tract. Consequently, it is important to take care when handling these articles to ensure that the release of dust is kept to a minimum. To ensure that the release of fibres from these RCF articles is kept to a minimum, during installation and servicing we recommend that you use a HEPA filtered vacuum to remove any dust and soot accumulated in and around the fire before and after working on the fire. When replacing these articles we recommend that the replaced items are not broken up, but are sealed within a heavy duty polythene bag, clearly labelled as RCF waste. This is not classified as “hazardous waste” and may be disposed of at a tipping site licensed for the disposal of industrial waste. Protective clothing is not required when handling these articles, but we recommend you follow the normal hygiene rules of not smoking, eating or drinking in the work area and always wash your hands before eating or drinking. This appliance does not contain any component manufactured from asbestos or asbestos related products.

Gas	Natural (G20)
Inlet Pressure	20mbar
Input Max. (Gross)	5.1kW (17,400 Btu/h)
Input Min. (Gross)	3.0kW (10,236 Btu/h)
Inlet Test Pressure (Cold)	20.0 ± 1.0mbar (8.0 ± 0.4in w.g.)
Gas Connection	8mm pipe
Burner Injector	Stereomatic Cat. 82 Size 065
Pilot & Atmosphere Sensing Device	Copreci Ref. O.D.S 21500/166
Ignition	Integral piezo (Mounted on gas valve)
Aeration	Non-adjustable

This appliance does not contain any components manufactured from asbestos or asbestos related products.

INSTALLER GUIDE

3. GENERAL INSTALLATION REQUIREMENTS

3.1 The installation must be in accordance with these instructions.

For the user's protection, in the United Kingdom it is the law that all gas appliances are installed by competent persons in accordance with the current edition of the Gas Safety (Installation and Use) Regulations. Failure to install the appliance correctly could lead to prosecution. The Council for the Registration of Gas Installers (CORGI) requires its members to work to recognised standards.

In the United Kingdom the installation must also be in accordance with:

All the relevant parts of local regulations.

All relevant codes of practice.

The relevant parts of the current editions of the following British Standards:-

BS 1251

BS 4543 Part 2

BS 5440 Part 1

BS 5440 Part 2

BS 5871 Part 3

BS 6461 Part 1

BS 6891

BS 8303

In England and Wales, the current edition of the Building Regulations issued by the Department of the Environment and the Welsh Office. In Scotland the current edition of the Building Standards (Scotland) Regulations issued by the Scottish Executive. In Northern Ireland, the current edition of the Building Regulations (Northern Ireland) issued by the Department of the Environment for Northern Ireland. In the Republic of Ireland the installation must also conform with the relevant parts of:

The current editions of:-

IS 813 "Domestic Gas Installations"

ICP3

IS327

All relevant national and local rules in force.

Where no specific instructions are given, reference should be made to the relevant British Standard Code of Practice.

3.2 In the United Kingdom, as supplied the appliance can be installed in the following situations: -

- To a fireplace complete with surround and hearth as shown in figure 1 and complying with BS1251. The required fireplace, hearth, and clearance dimensions are shown in figure 1.

INSTALLER GUIDE

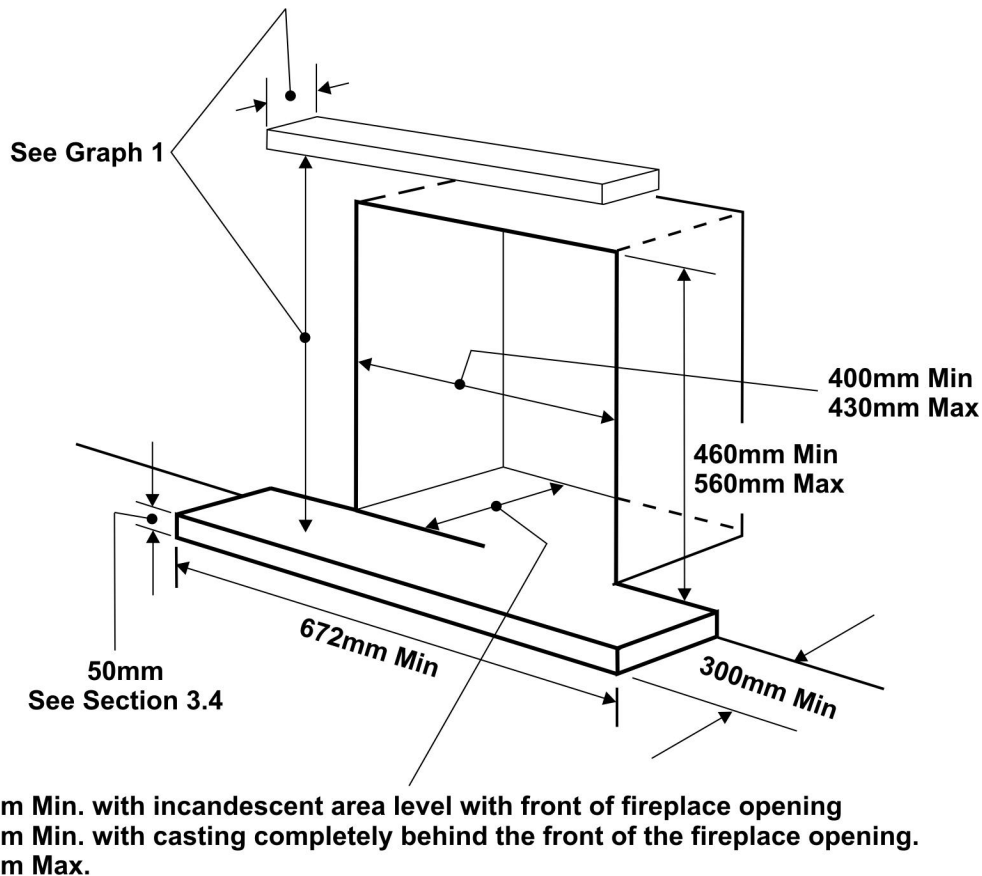

Figure 1. Hearth and fireplace opening.

Suitable flues and minimum flue sizes are as follows: -

225mm x 225mm conventional brick flue.

175mm diameter lined brick or stone flue.

200mm diameter factory made insulated flue manufactured to BS4543.

175mm diameter flue pipe. See BS6461 Part 1 for suitable materials.

The minimum effective height of the flue must be 3m.

The flue must not be used for any other appliance or application.

Any chimney damper or restrictor should be removed. If removal is not possible, they must be secured in the open position.

If the appliance is intended to be installed to a chimney that was previously used for solid fuel, the flue must be swept clean prior to installation.

All flues should be inspected for soundness and freedom from blockages.

3.3 If the fireplace opening is an underfloor draught type, it must be sealed to stop any draughts.

INSTALLER GUIDE

3.4 The appliance must be mounted behind a non-combustible hearth (N.B. conglomerate marble hearths are considered as non-combustible). The appliance can be fitted to a minimum class “O” – 100°C surround. The hearth material must be at least 12mm thick. The periphery of the hearth (or fender) should be at least 50mm above floor level to discourage the placing of carpets or rugs over it (See figure 1). The surface of the hearth must be sufficiently flat to enable the bottom of the front surround and the bottom front cover to be aligned horizontally. Any excessive unevenness (uneven tiles, Cotswold stone, etc.) should be rectified.

3.4.1. 'Hole-in-the-wall' installations.

It is recommended that a hearth should be installed as in figure 1.

If a reduced depth hearth is fitted, the fire must be installed so that the distance from the base of the fireplace opening in the wall to the finished floor level is 77mm minimum. Also, ensure that the reduced depth hearth is deep enough to support the lower firefront. The minimum shelf height will have to be taken from the base of the fireplace opening.

3.5 If the Fireplace opening is greater than the acceptable dimensions given in this guide, do not use the back of a fire surround or marble to reduce the opening. This may cause cracking of the surround back or marble

3.6 The appliance must not stand on combustible materials or carpets.

3.7 The minimum height from the top of the hearth / base of the fireplace opening to the underside of any shelf made from wood or other combustible materials is as follows:

- *For a shelf up to 150mm deep*
Minimum height = 775mm.
- *For a shelf deeper than 150mm*
775mm + 12.5mm for every 25mm depth over 150mm (See Graph 1).

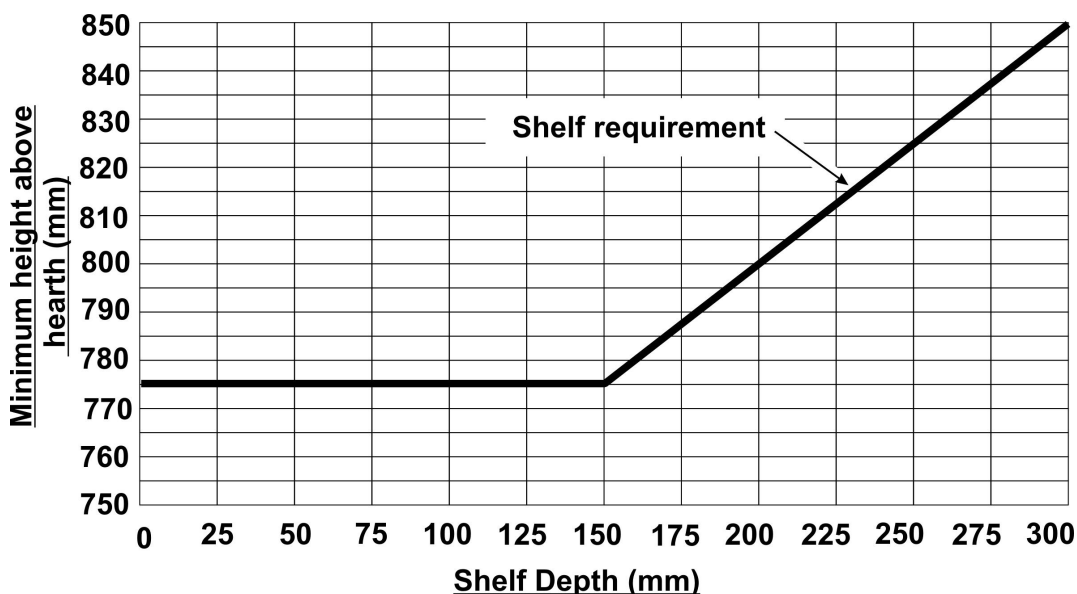

Graph 1. Combustible shelf clearances

INSTALLER GUIDE

3.8 Note that soft wall coverings (e.g. embossed vinyl, etc.) are easily affected by heat. They may scorch or become discoloured when close to a heating appliance. Please bear this in mind when installing.

3.9 This appliance must not be installed in any room that contains a bath or shower or where steam is regularly present.

3.10 An extractor fan may only be used in the same room as this appliance, or in any area from which ventilation for the appliance is taken, if it does not affect the safe performance of the appliance. Note the spillage test requirements detailed further on in this manual. If the fan is likely to affect the appliance, the appliance must not be installed unless the fan is permanently disconnected.

3.11 Normal adventitious ventilation is usually sufficient to satisfy the ventilation requirements of this appliance. In GB reference should be made to BS 5871 Part 2 and in IE reference should be made to the current edition of IS 813 “Domestic Gas Installations” which makes clear the conditions that must be met to demonstrate that sufficient ventilation is available.

3.12 Propane gas appliances must not be installed in a room that is built entirely below ground level (see BS 5871 Part 3).

3.13 If the appliance is to be fitted against a wall with combustible cladding, the cladding must be removed from the area shown in figure 3

3.14 Combustible side projections up to 75mm forward of the fixing plane of the fire are to be a minimum of 125mm from the fireplace opening (See figure 4)

3.14.1 Combustible side projections greater than 75mm forward of the fixing plane of the fire are to be a minimum of 178mm from the fireplace opening (See figure 4).

3.14.2 Non-combustible side projections to be 75mm from the fireplace opening (See figure 4)

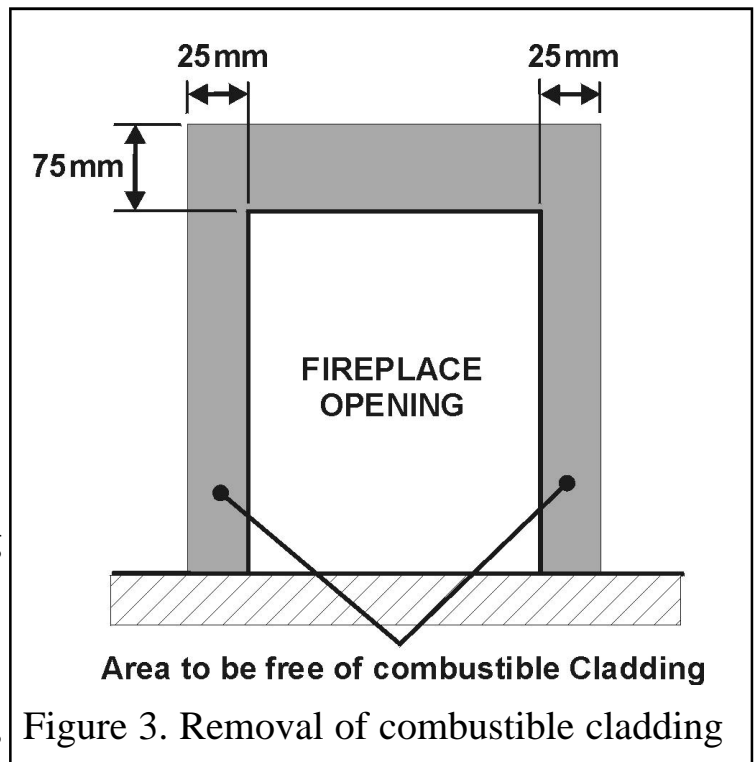

Figure 3. Removal of combustible cladding

Combustible projections up to 75mm forward of the fixing plane of the fire are to be a minimum of 125mm from the fireplace opening. Projections above 75mm forward of the fixing plane of the fire are to be a minimum of 178mm from the fireplace opening. Non-combustible projections are to be 75mm from the fireplace opening.

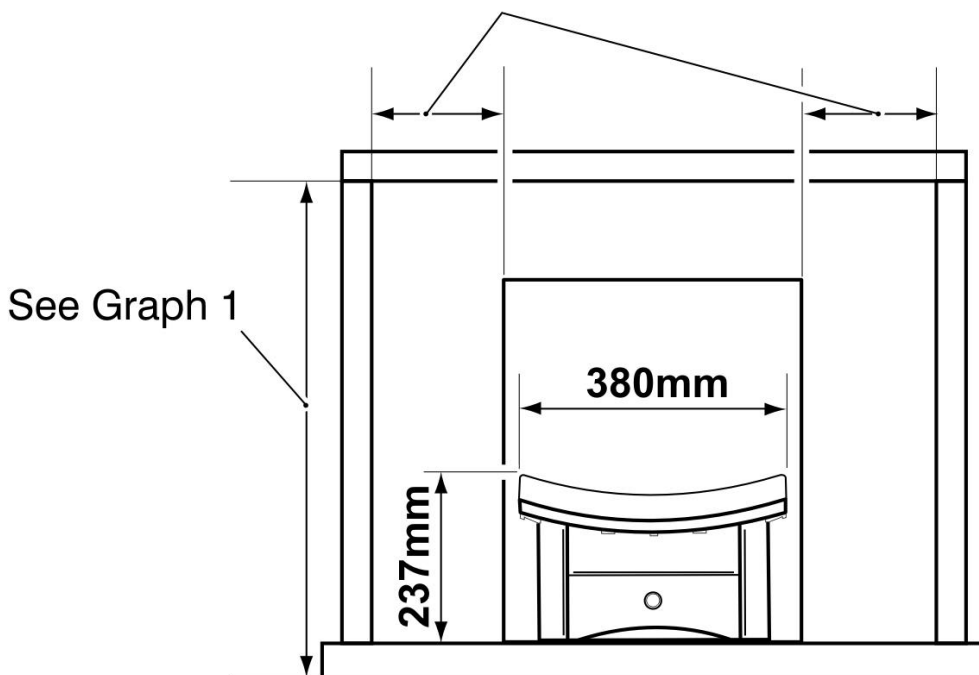

Figure 4. Appliance dimensions

3.15 The appliance is fitted with an A.S.D (Atmosphere sensing device). If the appliance closes down after a period of operation for no apparent reason, the consumer should be informed to stop using the appliance until the installation and appliance have been thoroughly checked. The A.S.D will shut the appliance down if an unacceptable amount of harmful products of combustion accumulate. Under no circumstances should the A.S.D be altered or bypassed in any way. Only a genuine manufacturers replacement part should be fitted. The individual A.S.D components are not replaceable.

3.16 A fireguard complying with BS 8423 should be fitted for the protection of young children, the elderly, or the infirm.

INSTALLER GUIDE

4. PACK CONTENTS

Contents:

- 1 Burner assembly with firefront cover
- 1 Casting
- 1 Casting bracket
- 2 M5 Taptite screws (For securing the casting bracket to the casting)
- 2 Self tapping screws (For securing the casting to the top of the burner tray)
- 1 M5 Taptite screw (For securing the casting to the rear of the body)
- 1 Inlet 'T' connector
- 1 Nut & olive for 8mm inlet pipe
- 1 Floor plate
- 1 M4 Machine screw (For securing the burner unit to the floor plate)
- 3 Plastic screw plugs (For securing the floor plate)
- 3 Woodscrews (For securing the floor plate).
- 1 Ceramic fuel effect pack.

Carefully remove the contents. Take special care in handling the ceramic fuel effect pieces. Check that all the listed parts are present and in good condition.

5. INSTALLATION OF APPLIANCE

INSTALLATION

5.1 Fireplace size.

The fireplace must comply with the requirements described in section 3.

5.2 Fireplace flue pull.

Visually inspect the flue for any obstruction, and that a smooth transition from the fireplace opening into the flue is available. Close all doors and windows in the room in which the appliance is to be installed. After confirming with a match that smoke is drawn into the flue, light a 13 gram smoke pellet and check that there is a definite flow through the flue. Verify outside that the smoke exits from one terminal only and that the termination is suitable. Observe, where possible, upstairs rooms and loft spaces for signs of escaping smoke indicating a defective flue. If there is not a definite flow warm the flue for a few minutes and repeat the smoke pellet test. If there is still no definite flow the flue may need remedial work – **Do not fit the appliance until there is a definite flow through the flue.**

INSTALLER GUIDE

5.3 Installation of the burner unit

5.3.1 Fitting the top casting.

Supplied with the fire are a top casting and casting bracket.

- Secure the bracket to the underside of the casting. To do this place the casting face down on a flat surface. Locate the bracket as in figure 5 and secure with the two screws supplied.
- Place the casting onto the top of the burner unit. The bracket should be in front of the burner (See figure 6).
- Secure the bracket in place with the two screws supplied (See figure 6).
- At the top rear of the burner unit there is a hole. Secure the rear of the casting using the screw supplied (See figure 7). It may be necessary to apply pressure to the top of the casting to line up the holes.

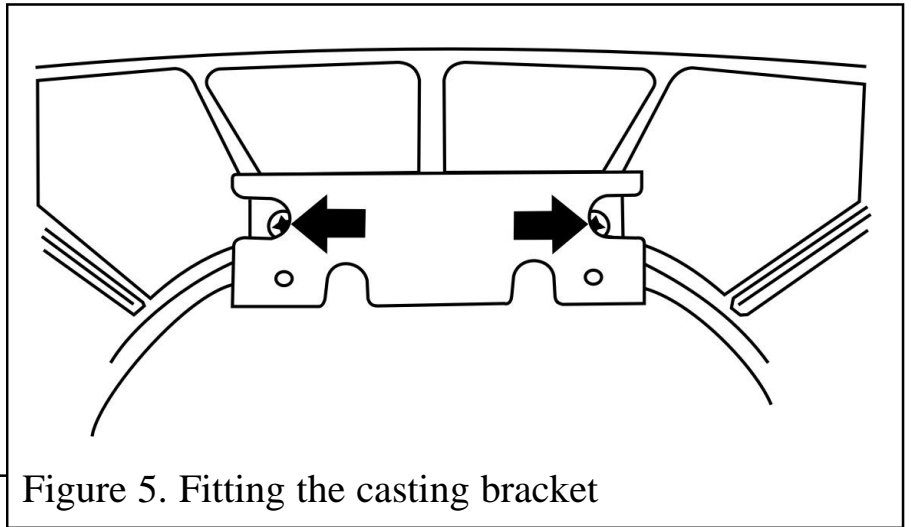

Figure 5. Fitting the casting bracket

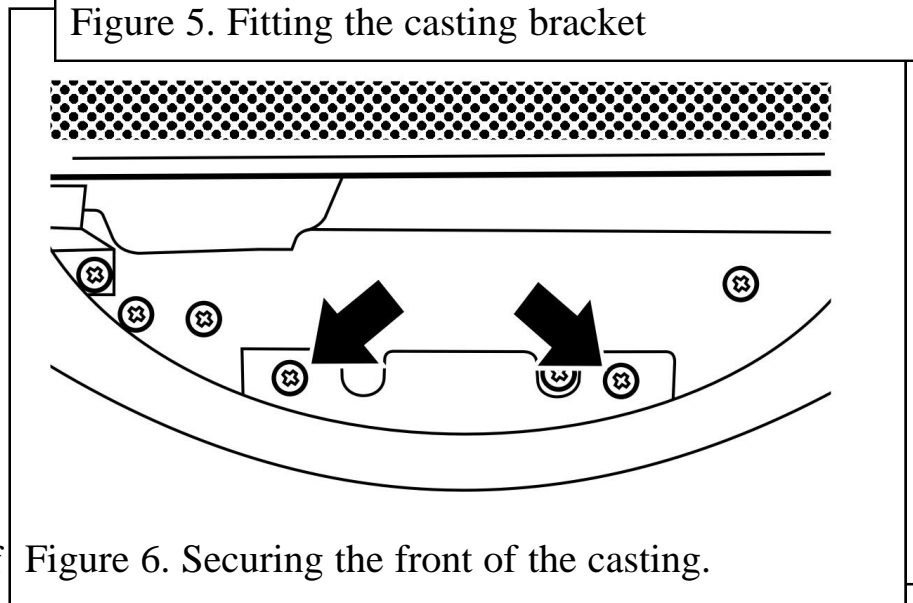

Figure 6. Securing the front of the casting.

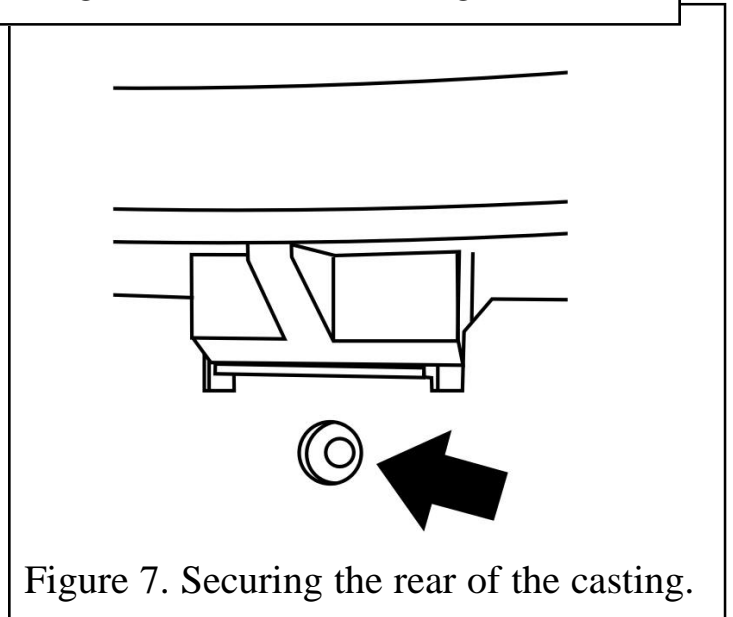
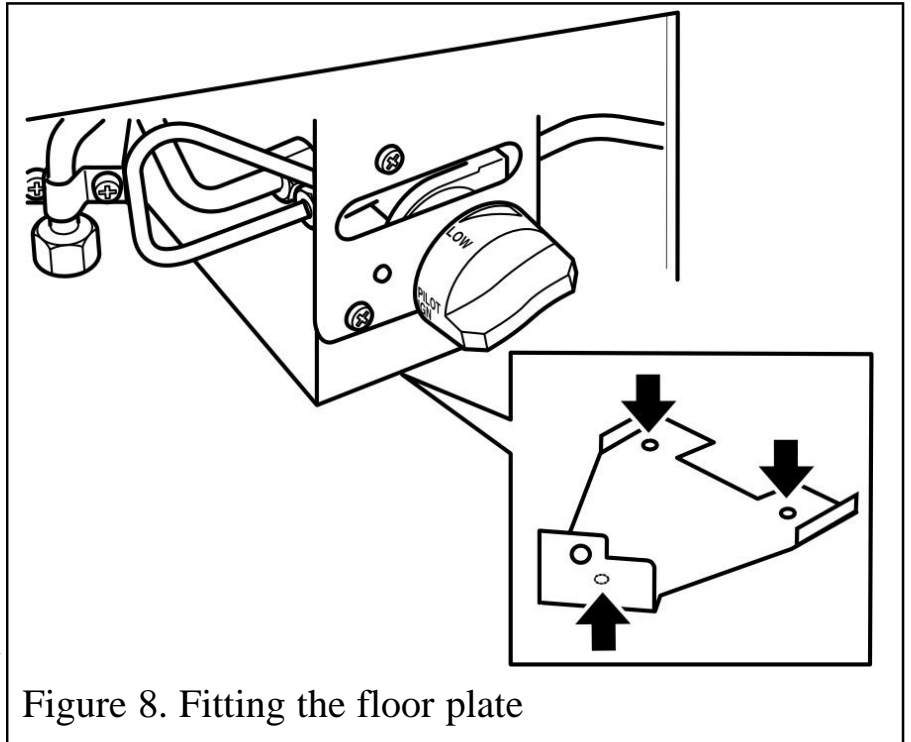

Figure 7. Securing the rear of the casting.

INSTALLER GUIDE

5.3.2 Locating the burner.

- Remove the firefront cover from the bottom of the burner unit.
- Fit the floor securing plate to the bottom of the burner unit as in figure 8 using the machine screw supplied.
- Ensure that the burner assembly is positioned as in section 5.3.3.
- Mark on the fireplace floor the position of the floor plate.
- Remove the burner unit from the fireplace.
- Remove the floor plate from the burner unit.
- Place the floor plate in the marked position in the fireplace. There are three holes in this bracket to prevent burner movement in use (See figure 8).
- Mark the hole positions and remove the bracket.
- Using a 6mm masonry drill, drill into the hearth at the marked position.
- Insert the supplied screw plugs.
- Place the bracket in position on the fireplace floor and fix in position using the woodscrews provided.



5.3.3 Burner positioning.

Place the burner unit centrally within the fireplace opening. Position the burner to the rear of the opening, this may be moved forward providing the front of the burner tray does not protrude beyond the front plane of the fireplace opening by more than 50mm (See figure 9).

5.3.4 Fitting the burner.

- Place the burner assembly back in position and attach to the bracket by refitting the screw in the front support leg.

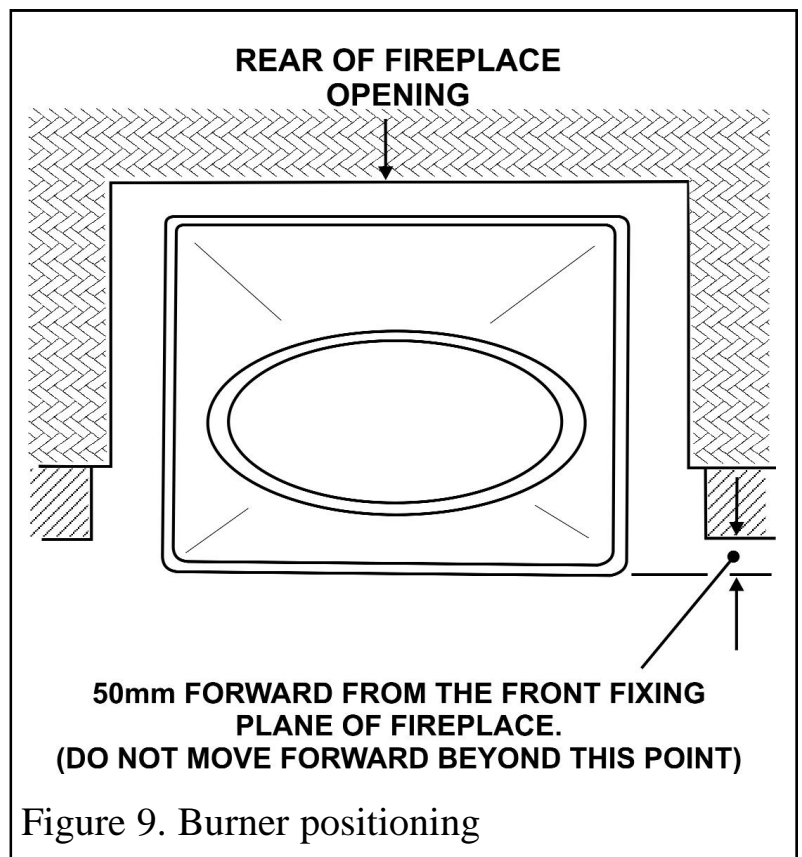

INSTALLER GUIDE

6. BURNER AND SUPPLY PIPE INSTALLATION

A nut and olive is provided for an 8mm-pipe inlet connection directly to the gas control. The inlet 'T' connector can be rotated to allow a rear-concealed connection. The inlet 'T' connector includes a valve for isolating the gas supply. Note that the centre of the appliance inlet 'T' connector is 25mm above the fireplace floor. The inlet 'T' connector should be fitted to the supply pipe at this stage.

The supply pipe must be rigid material. Flexible pipe must not be used. Connect the supply line to the appliance.

Turn on the gas supply and pressure check the installation pipework for gas soundness. In the United Kingdom (GB) check in accordance with the current edition of BS 6891. In the Republic of Ireland check in accordance with the current edition of IS 813 "Domestic Gas Installations".

6.1 Preliminary burner checks.

Some burner operations can be checked at this stage. Checking now will mean that less disassembly will be required if any problems are found. *A full check should still be made, however, after final installation.*

6.1.1 Lighting the fire

If closed, open the isolating inlet 'T' connector. Depress the control knob and rotate it anticlockwise to the 'pilot ignition' position. A 'click' will be heard as the integral piezo operates. A spark should be seen between the electrode and pilot tip. Turn the control knob clockwise to the 'Off' position. Repeat this operation until a flame appears at the pilot. There may be a delay before the pilot lights due to air being purged from the system. When a flame appears at the pilot keep the control knob depressed and hold the pilot ignition position for five seconds. When the control knob is released the pilot flame should remain lit.

6.1.2 Operating the burner.

When the pilot burner is operating properly, gradually turn the control knob anti-clockwise to 'HIGH' (Depress the knob slightly to get past the pilot ignition position). The main burner should now light. Depress the control knob slightly to release from the 'HIGH' position and turn back (clockwise) to 'LOW'. While turning, the burner flames should gradually become lower but remain alight. Depress the control knob slightly to release from the 'LOW' position and turn back (clockwise) to the 'Pilot ignition' position. The main burner should extinguish but the pilot should remain alight. Depress the control knob slightly and turn back (clockwise) to turn OFF.

This will extinguish the pilot.

INSTALLER GUIDE

6.1.3 Checking the inlet pressure.

The appliance is pre-set to give the correct heat input at the inlet pressure shown in section 2 of this manual. No adjustment is necessary.

1. Check the inlet pressure by fitting a pressure gauge at the test point. The test point is on the inlet 'T' connector (See figure 10). Check the pressure with the appliance alight and set at maximum output.
2. After checking, turn off the appliance. Remove the pressure gauge and replace the test point sealing screw.
3. Relight the appliance. Turn to the maximum output position and test around the sealing screw for gas soundness with a suitable leak detection fluid.

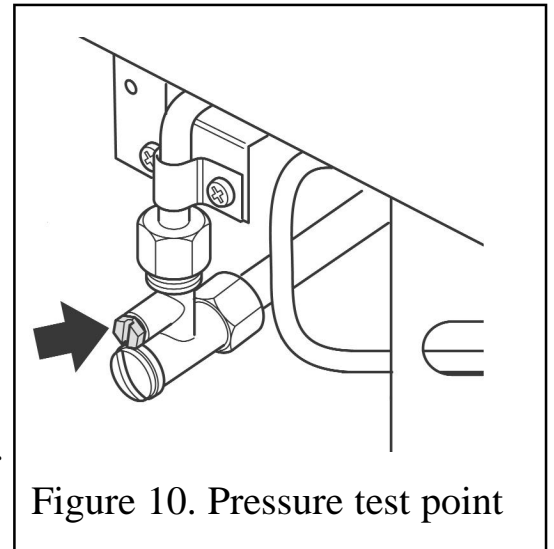

Figure 10. Pressure test point

7. FITTING THE CERAMIC FUEL EFFECT

The installer and owner guide for the ceramic fuel effect is supplied with the ceramic fuel effect. It is important that the fitting guide for the ceramic fuel effect be placed inside or attached to this guide and handed to the customer following completion of the 'Final review' section.

8. FULL OPERATING CHECKS

Spillage check.

- A spillage check must be made before leaving the installed appliance with the customer. Make this with all the ceramic fuel effect pieces and firefront cover in position (See figure 11)
- Close all doors and windows in the room containing the appliance. Light the appliance and set the control to the 'HIGH' position. Leave the appliance on for five minutes (See lighting instructions within section 6 of this guide).
- The end of the smoke match should be level with the front face of the fireplace opening.
- The installation is satisfactory if the smoke is drawn into the fireplace opening. If

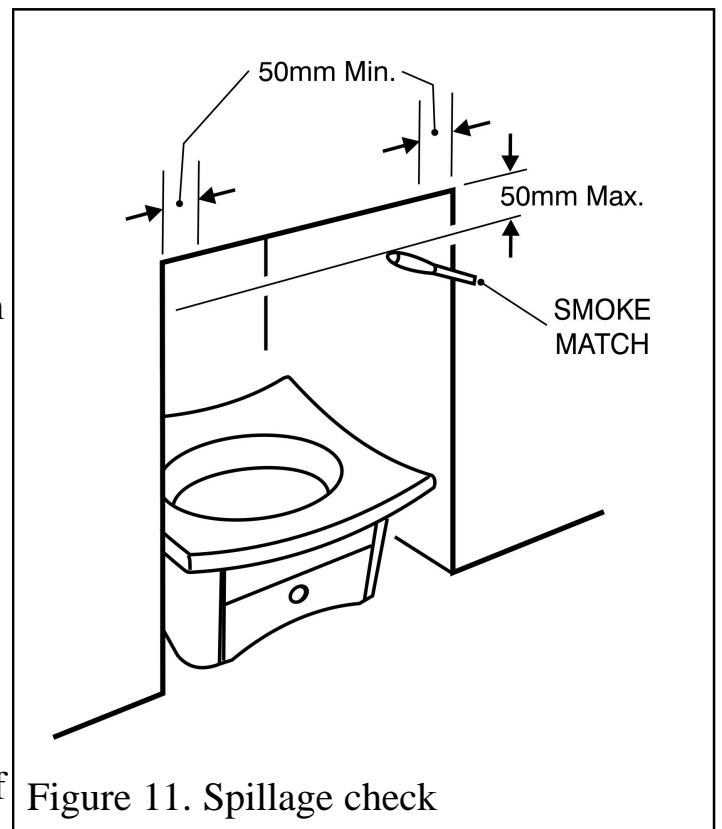

Figure 11. Spillage check

INSTALLER GUIDE

the smoke is not drawn into the fireplace opening, leave the appliance alight at the maximum setting for a further ten minutes and then repeat the test. If smoke is still not drawn into the appliance ***disconnect the appliance and seek expert advice.***

- If the above test is satisfactory, open all internal connecting doors, hatches, etc. in the room. Keep all doors and windows that open to the outside of the building closed. Switch on any extractor fan installed in the same room as the appliance or a connecting room. Open all doors and other openings between the fan and the appliance. Recheck for spillage as above. If the smoke is drawn into the appliance, continue with the installation. If the test is not satisfactory, ***disconnect the appliance and advise the customer of the cause of failure.***

Flame supervision and spillage monitoring system.

The pilot unit incorporates a system that will automatically shut off the gas supply if the pilot flame goes out or if there is insufficient oxygen due to spillage or lack of ventilation.

Check that the system operates properly as follows:

- Light the appliance. Set at the “HIGH” position and leave for one minute.
- Turn back to “OFF” to extinguish the pilot. **Note the time when the pilot goes out.** Listen for a snap sound at the gas tap. **Note the time when the sound is heard.** An electromagnetic valve shutting off the gas supply through the tap causes this sound. The valve is located in the body of the tap. The valve should operate **within 60 seconds of the pilot going out.** If the valve does not operate within this time limit do not allow the appliance to be used until the fault has been corrected.

This monitoring system must not be adjusted, bypassed or put out of operation. This monitoring system, or any of its parts, must only be exchanged using Baxi Fires Division authorised parts.

Final commissioning.

- Fit the firefront cover in place.
- Visually inspect the appliance. Clean off any marks incurred during installation.
- Hand this guide to the customer.
- ***Stress that no extra ceramic fuel effect pieces must be added over and above those supplied with the appliance and that any replacements must only be authorised spares. Warn that ignoring this advice could cause incomplete clearance of the products of combustion with consequent health hazards.***
- Advise the customer how to operate the appliance. Point out that lighting instruction details are contained within the owner guide.
- Explain that this appliance is fitted with an atmosphere-sensing device, ODS pilot unit that will automatically shut off the supply of gas to the fire if, for any reason, the flames go out. It will also shut off the gas supply if the flue is blocked or if there is not enough ventilation. If this device does operate or if the fire is turned off accidentally or

INSTALLER GUIDE

intentionally, always wait three minutes before attempting to relight.

- Advise the customer that the fire front and ceramic fuel effect pieces can be cleaned as described in the owner guide and that the ceramic fuel effect pieces must be replaced as described in the installer and owner guide for the ceramic fuel effect. Place or attach the installer and owner guide for the ceramic fuel effect in this guide.
- Recommend that the appliance should be serviced and the chimney inspected by a competent person at least annually.

9. SERVICING & PARTS REPLACEMENT

Always turn off the gas supply before commencing any servicing (The appliance inlet 'T' connector incorporates an isolating valve).

It is recommended that, at least once a year, the appliance is disconnected and the fireplace opening checked and cleared of any debris.

This product uses fuel effect pieces containing Refractory Ceramic Fibres (RCF), which are man-made vitreous silicate fibres. Excessive exposure to these materials may cause irritation to eyes, skin and respiratory tract. Consequently, it is important to take care when handling these articles to ensure that the release of dust is kept to a minimum. To ensure that the release of fibres from these RCF articles is kept to a minimum, during installation and servicing we recommend that you use a HEPA filtered vacuum to remove any dust and soot accumulated in and around the fire before and after working on the fire. When replacing these articles we recommend that the replaced items are not broken up, but are sealed within a heavy duty polythene bag, clearly labelled as RCF waste. This is not classified as "hazardous waste" and may be disposed of at a tipping site licensed for the disposal of industrial waste. Protective clothing is not required when handling these articles, but we recommend you follow the normal hygiene rules of not smoking, eating or drinking in the work area and always wash your hands before eating or drinking.

- Check that the appliance is clean and that soot or debris is not blocking the gaps between the ceramic fuel effect pieces causing an imperfect flame.
- Check that soot or debris is not impairing the electrode spark or pilot burner.
- Check that soot or debris is not blocking any of the slots in the main burner.
- After servicing, make sure that the ceramic fuel effect pieces are replaced correctly as described in the installation instructions.
- **Always test for gas soundness and spillage after servicing the appliance.**

9.1 To remove the complete burner unit.

1. Remove the firefront cover and place in a safe position.
2. Remove the ceramic fuel effect.

INSTALLER GUIDE

3. Close the valve in the inlet 'T' connector .
4. Disconnect the appliance from the inlet 'T' Connector.
5. Remove the front leg fastening screw. This is located to the left of the control knob.
6. Lift the burner out of the fireplace opening.
7. Replace in the reverse order.
8. Make sure gas soundness, sealing, spillage test and performance are satisfactory.

9.2 To remove the pilot unit.

1. Remove the burner unit (See section 9.1).
2. If lying the burner on its back, ensure that the work surface is suitably protected This will avoid damage to the work surface. Detach the pilot pipe from the pilot unit.
3. Detach the thermocouple from the gas valve
4. Detach the electrode lead from the underside of the electrode tab.
6. Remove the two screws securing the pilot unit (See figure 12).
7. Refit in the reverse order.

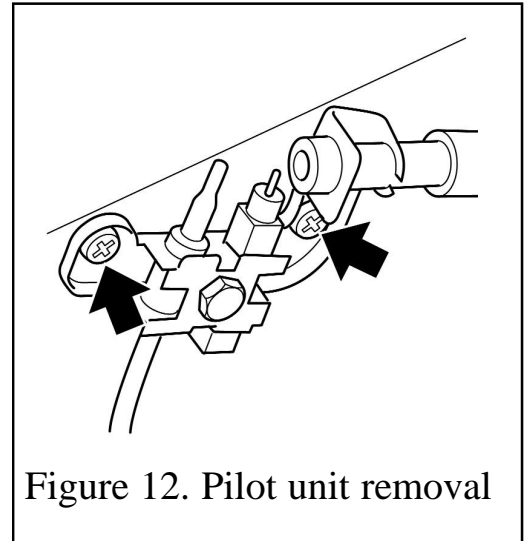

Figure 12. Pilot unit removal

Note: 1. The pilot unit is an atmosphere sensing device. It must be replaced as a whole assembly. Its individual components are not separately replaceable.

9.3 To remove the gas valve.

(See figure 13).

1. Remove the complete burner unit (See section 9.1).
2. If lying the burner on its back, ensure that the work surface is suitably protected. This will avoid damage to the work surface. Turn the burner unit upside down. Detach the thermocouple from the tap
3. Detach the pilot pipe from the tap.
4. Detach the inlet pipe.
5. Detach the injector pipe
6. Detach the electrode lead from the base of the electrode
7. Remove the control knob by pulling forward.

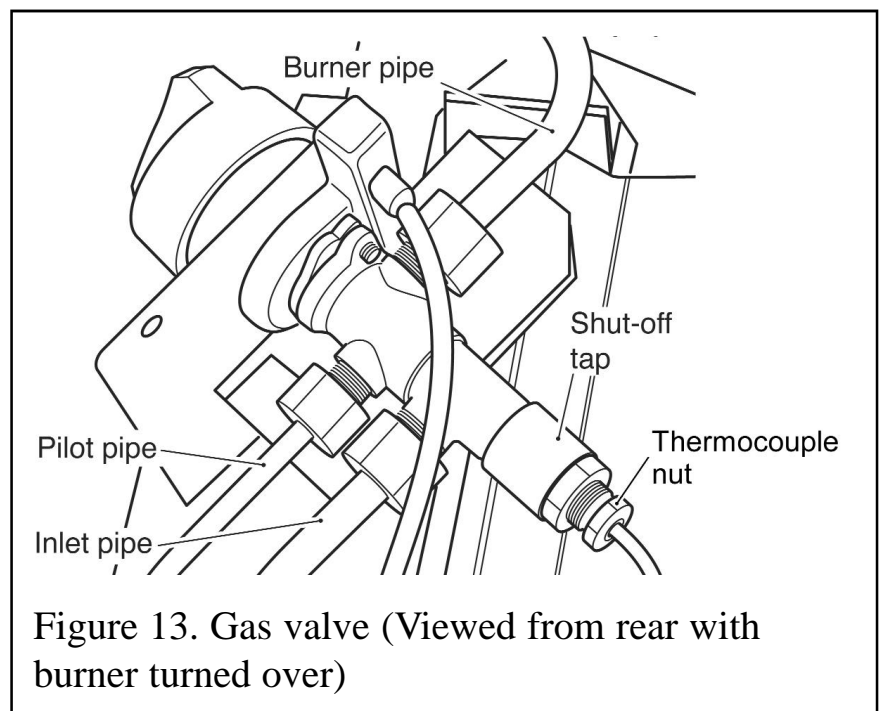

Figure 13. Gas valve (Viewed from rear with burner turned over)

INSTALLER GUIDE

8. Remove the thermocouple by unscrewing the thermocouple nut at the gas valve.
9. Remove the hexagonal nut securing the gas valve to the mounting bracket.
10. Remove the gas valve
11. Refit in the reverse order.

9.4 To remove the piezo generator.

1. Remove the gas valve as section 9.3.
2. Make sure that the tap is in the off position.
3. Remove the circlip holding the piezo unit to the tap. Remove the piezo unit.
4. Replace in the reverse order.

9.5 To grease the control tap.

1. Detach the tap and remove the piezo generator as section 9.4 making sure that the tap is in the 'off' position.
2. Remove the two screws from the head of the tap. Remove the niting head and spindle complete with collar and spring.
3. Note the position of the slot in the plug - mark its position on the tap body.
4. Remove the plug rotating slightly while pulling.
5. Clean and grease the plug lightly with suitable grease. Do not apply excessive grease. Particularly, make sure that the gas ports in the tap are not restricted by grease.
6. Push the plug into the tap body and position the slot in line with the mark previously made on the tap body.
7. Reassemble the niting head and spindle complete with collar and spring making sure that the components are correctly engaged. Check the operation of the tap.
8. Refit the piezo generator.

9.6 To replace the burner.

(See figure 14).

1. Remove the complete burner unit (See section 9.1).
2. Support the elbow injector and unscrew the injector nut.
3. Remove the two screws from the burner clamping plate (See figure 14)
4. Lift the right hand side of the burner, slide it to the right and lift clear
5. Refit in reverse order.

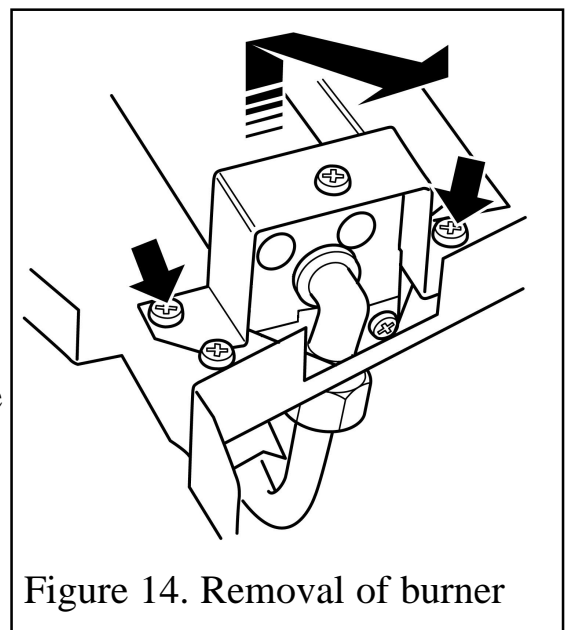

Figure 14. Removal of burner

INSTALLER GUIDE

9.7 To remove the main burner injector.

(See figure 15).

1. Remove the burner (See section 9.6).
2. Remove the burner clamping screw (See figure 15)
3. Unscrew the injector from the burner.
4. Refit in the reverse order.

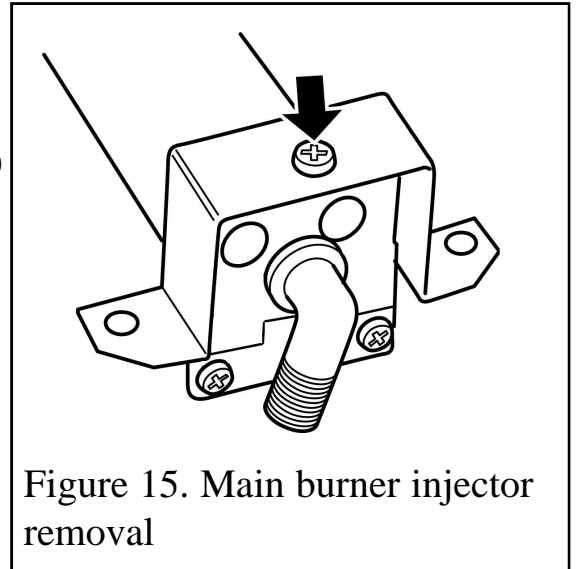

Figure 15. Main burner injector removal