

# BAXI FIRES DIVISION

## OWNER GUIDE

### Model 759

OPEN DECORATIVE GAS FIRE

Fitted with



**ARC** fascia

(GC No. 32-032-68)

**THIS APPLIANCE IS FOR USE WITH NATURAL GAS (G20).  
THIS APPLIANCE IS SUITABLE ONLY FOR INSTALLATION IN THE UNITED  
KINGDOM (GB) AND THE REPUBLIC OF IRELAND (IE).**

We trust that this guide gives sufficient details to enable this appliance to be installed and maintained satisfactorily. However, if further information is required, our **Baxi Fires Division Technical Helpline** will be pleased to help.  
**Please telephone 08706 061 065** (National call rates apply).  
In the Republic of Ireland telephone **0044 8706 061 065**

This guide is intended to help you care for your gas fire. Please read thoroughly before using and keep for future reference.

**BAXI • VALOR • WONDERFIRE**

**INSTALLER: Please leave this guide with the owner**

# OWNER GUIDE

## **Safety First.**

Baxi Fires Division fires are CE Approved and designed to meet the appropriate British Standards and Safety Marks.



## **Quality and Excellence.**

At the heart of every Baxi Fires Division fire.

All Baxi Fires Division fires are manufactured to the highest standards of quality and excellence and are manufactured under a BS EN ISO 9001 quality system accepted by the British Standards Institute.



## **The Highest Standards**

Baxi Fires Division is a member of the Society of British Gas Industries which works to ensure high standards of safety, quality and performance.



## **Careful Installation**

Baxi Fires Division is a CORGI registered company. All our gas fires must be installed by a competent CORGI Registered Installer in accordance with our Installer Guide and should not be fitted directly on to a carpet or floor of combustible material.

# B A X I F I R E S D I V I S I O N

Baxi Fires Division, Erdington, Birmingham B24 9QP

[www.firesandstoves.co.uk](http://www.firesandstoves.co.uk)

Because our policy is one of constant development and improvement, details may vary slightly from those given in this publication

# OWNER GUIDE

## LIST OF CONTENTS

<u>Section</u>	<u>Page</u>
<b>SAFETY</b>	<b>4</b>
<b>GAS CONSUMPTION</b>	<b>5</b>
<b>APPLIANCE DIMENSIONS</b>	<b>6</b>
<b>OPERATING THE FIRE</b>	<b>6</b>
The Oxysafe flame sensing & flue blockage safety system.	6
To light the fire.	7
Lighting with a taper.	8
<b>CLEANING YOUR FIRE</b>	<b>8</b>
Metal parts and enamelled top.	8
Ceramic fuel effect .	8
Burner.	9
<b>CERAMIC FUEL EFFECT REFITTING</b>	<b>9</b>
<b>MAINTENANCE</b>	<b>9</b>
<b>USEFUL TELEPHONE NUMBERS</b>	<b>10</b>

---

This gas fire is designed to meet the most stringent quality, performance and safety requirements to provide you with many years' trouble-free service.

This guide aims to improve your understanding and appreciation of your gas fire by providing simple and informative instructions to ensure that you benefit from the excellent performance and features it has to offer.

# OWNER GUIDE

## SAFETY

### IF YOU SMELL GAS

**DON'T SMOKE**

**EXTINGUISH ALL NAKED FLAMES**

**DON'T TURN ELECTRICAL SWITCHES ON OR OFF**

**TURN OFF THE GAS SUPPLY AT THE METER**

**OPEN DOORS AND WINDOWS TO GET RID OF THE GAS**

**IMMEDIATELY CALL THE GAS EMERGENCY SERVICE - SEE YOUR LOCAL TELEPHONE DIRECTORY**

**Do** have the fire installed by a competent person. In the United Kingdom, installation must be in accordance with the latest edition of the Gas Safety (installation & use) Regulations. In the Republic of Ireland, installation must be in accordance with all national and local regulations in force.

**Do** have the chimney swept prior to installation if it was previously used for solid fuel.

**Do** have the fire installed in accordance with the installation instructions.

**Do** provide a minimum clearance of 775mm from the base of the hotbox to any shelf made of wood or other combustible material where the shelf is not more than 150mm deep. For a shelf deeper than 150mm, add 12.5mm to the clearance for every 25mm of additional shelf depth (See graph1).

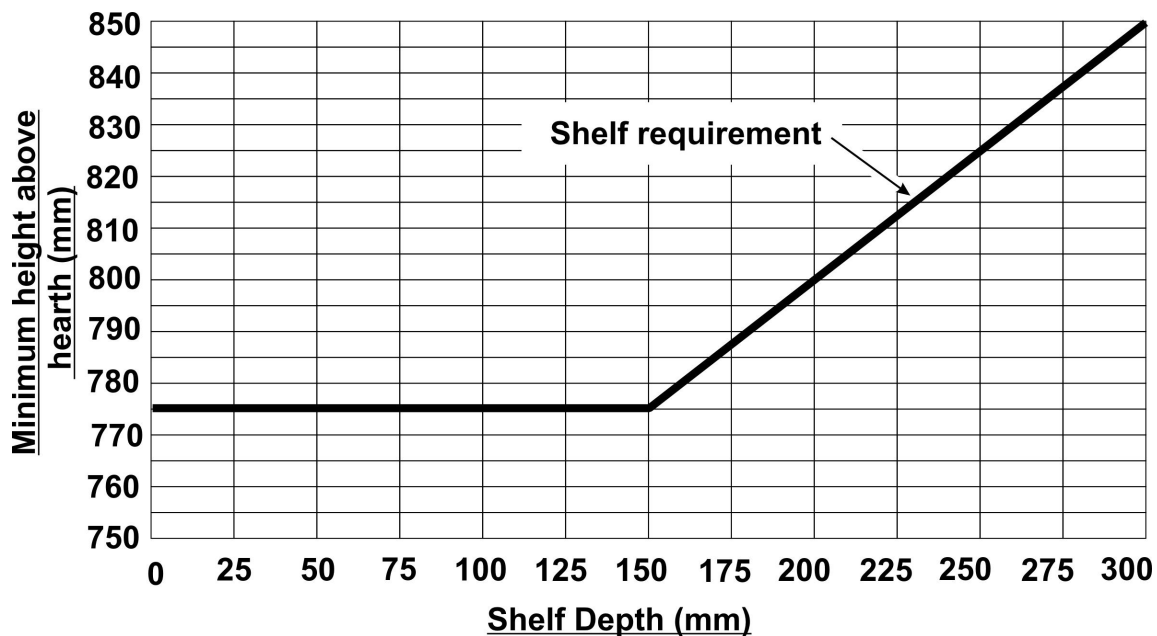

Graph 1. Combustible shelf clearances

**Do** provide a suitable guard that complies with BS 8423 for the protection of young children, the elderly and the infirm. Such a guard is also recommended for the protection of pet animals. (Although this fire conforms to all the applicable

## OWNER GUIDE

standards, it is a heating appliance and certain parts of its surface will become hot.).

**Do** wait three minutes before attempting to relight if the fire is switched off or the flames are extinguished for any reason. (Your fire is fitted with a safety device that will automatically shut off the gas supply to the fire if, for any reason, the flames go out.).

**Do** get advice about the suitability of any wall covering near your fire. Soft wall coverings (e.g. embossed vinyl, etc.) which have a raised pattern are easily affected by heat. They may, therefore, scorch or become discoloured when close to a heating appliance. Please bear this in mind whenever you are considering redecorating.

**Do** provide a minimum side clearance as detailed in figure 1. Please bear this in mind if ever you are considering altering the room.

**Don't** hang clothing, towels or any other fabrics over the front of the fire.

**Don't** add any extra ceramic fuel effect pieces above the number stated in the installer and owner guide supplied with the ceramic fuel effect. This should have been placed inside or attached to this guide by the installer. This could cause incomplete combustion and consequent safety hazard.

**Don't** put paper or any other material on the fire.

**Don't** place any combustible material (rugs, carpet, plastic tiles, etc.) on the hearth.

**Don't** attempt to clean or service the fire until it has been switched off and allowed to cool completely.

## GAS CONSUMPTION

### Model 759

Has a maximum natural gas input of 5.1kW (Gross)

Has a minimum natural gas input of 3.0kW

# OWNER GUIDE

## APPLIANCE DIMENSIONS

Combustible projections up to 75mm forward of the fixing plane of the fire are to be a minimum of 125mm from the fireplace opening. Projections above 75mm forward of the fixing plane of the fire are to be a minimum of 178mm from the fireplace opening. Non-combustible projections are to be 75mm from the fireplace opening.

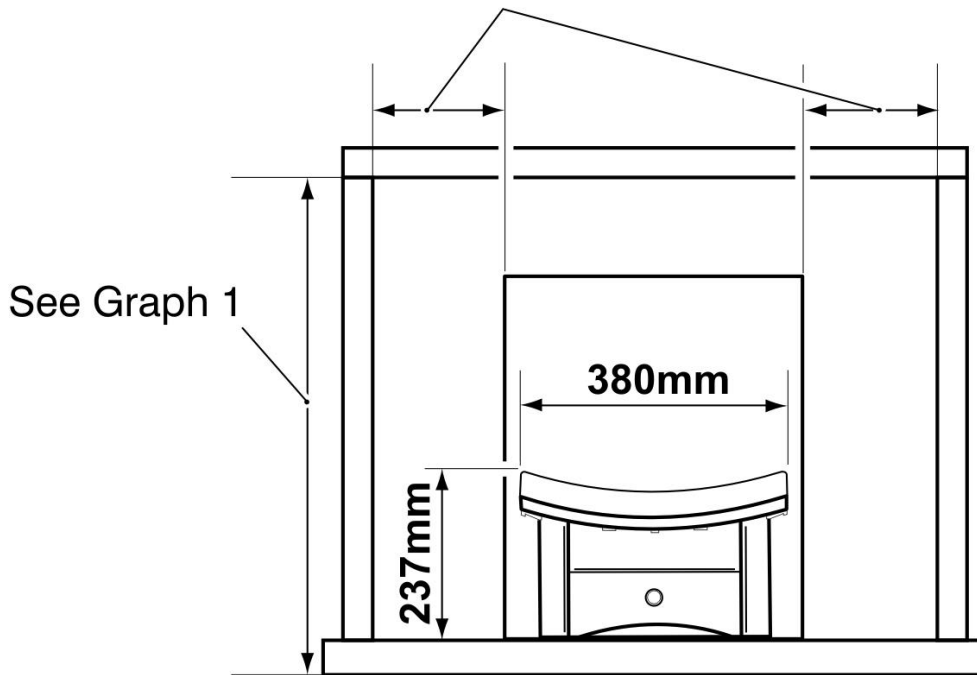

Figure 1. Appliance dimensions

## OPERATING THE FIRE

### *PLEASE NOTE*

When operating your fire for the first time, some vapours may be given off which may cause a slight odour and could possibly set off any smoke alarms in the immediate vicinity. These vapours are quite normal with new appliances. They are totally harmless and will disappear after a few hours use.

### **The Oxysafe flame sensing & flue blockage safety system.**

For your safety, this appliance is fitted with a flue blockage safety device that will shut down the appliance in the event of abnormal flue conditions. ***This device is NOT a substitute for an independently mounted Carbon Monoxide detector.***

The device will also automatically shut off the gas supply to the fire if the pilot flame goes out due to lack of oxygen or for any other reason.

***If this device starts to repeatedly shut off the gas, get expert advice.***

This device incorporates a probe that senses that the heat from the pilot flame is correct.

# OWNER GUIDE

If this probe is cool, the device will prevent any gas flow unless the control knob is held in at the ignition position.

If, for any reason, the flames go out when the fire is hot or if the fire is turned off when hot, always *wait at least three minutes before attempting to relight.*

## To light the fire.

Remove the firefront cover. Depress the control knob and rotate it anticlockwise to the pilot ignition position. A 'click' will be heard as the integral piezo operates. A flame should appear at the pilot. Keep the control knob depressed and hold the pilot ignition position for five seconds. When the control knob is released the pilot flame should remain lit. If a flame does not appear at the pilot then turn the control knob clockwise to the 'OFF' position and repeat the above.

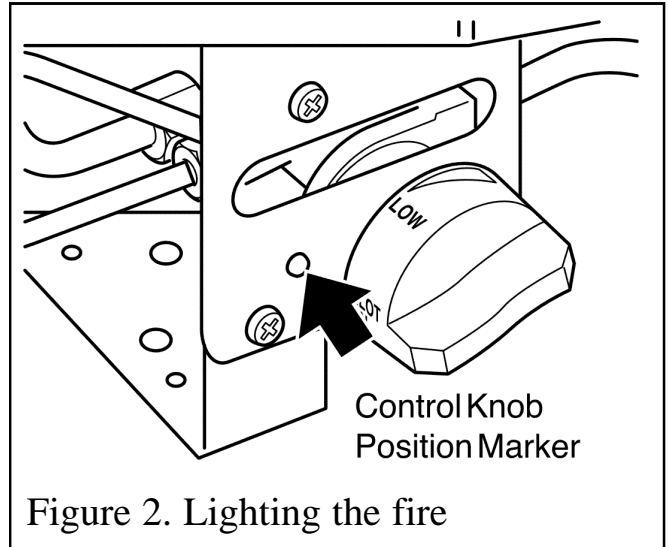

Figure 2. Lighting the fire

When the pilot burner is operating properly, gradually turn the control knob anti-clockwise to 'HIGH' position. (Depress the knob slightly to get past the pilot ignition position). The main burner should now light. Depress the control knob slightly to release from the 'HIGH' position and turn back (clockwise) to 'LOW'. While turning, the burner flames should gradually become lower but remain alight. Depress the control knob slightly to release from the 'LOW' position and turn back (clockwise) to the Pilot ignition position. The main burner should extinguish but the pilot should remain alight. Depress the control knob slightly and turn back (clockwise) to turn OFF. This will extinguish the pilot.

While cooling, the ceramic fuel effect may make some crackling noises. This is quite normal.

- If the flames go out while setting the control, repeat the full lighting procedure.
- If the flames repeatedly go out have the fire serviced.
- Please note. When first turned on the flames will appear predominantly blue. The ceramic fuel effect will take time to warm up. Although some glow will be seen after approximately ten minutes, the full visual effect will only be apparent after a somewhat longer time.
- The appliance will operate to its maximum potential if the flue is primed during the first 20 – 30 minutes of operation. To do this, simply turn the control knob to its 'HIGH' setting. This will also burn off any carbon deposits that may have formed during previous operations.
- If operating the appliance for long periods it is beneficial occasionally to change

## OWNER GUIDE

the settings. This will also help to remove any carbon deposits that may form during operation.

### Lighting with a taper.

See figure 3.

In the unlikely event of failure of the ignition spark, the pilot can be lit by a taper or long spill. Insert the taper or spill between the second and third left hand ceramic fuel effect pieces on the first row. Operate the control knob as described in the section headed 'To light the fire'.

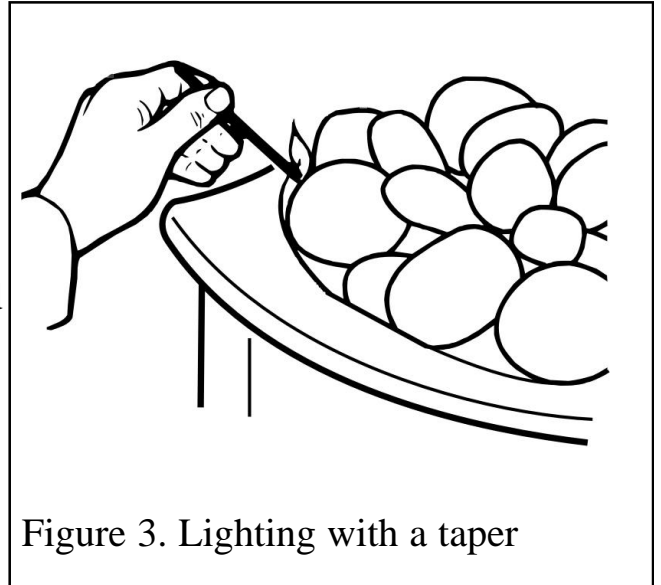

Figure 3. Lighting with a taper

## CLEANING YOUR FIRE

Turn the fire off and allow it to cool completely before attempting any cleaning. **Note that the fire will retain heat for some time after it has been turned off.**

*If large pieces of debris are found anywhere in the fireplace, have the chimney inspected before further use.*

### Metal parts and enamelled top.

Clean the metal or enamelled parts with a slightly damp cloth and then dry. ***Do not use abrasive cleaners, they could scratch the surface.***

### Ceramic fuel effect .

**This product uses fuel effect pieces containing Refractory Ceramic Fibres (RCF), which are man-made vitreous silicate fibres. Excessive exposure to this material may cause irritation to eyes, skin and respiratory tract.**

**Consequently, it is important to take care when handling these articles to ensure that the release of dust is kept to a minimum.**

- Light coatings of soot will usually be burnt off during the normal operation of the fire.
- Should any soot accumulation become excessive, the ceramic fuel effect pieces should be removed from the fire for cleaning.
- Cleaning should be carried out in a well-ventilated area or in the open air by gently brushing with the pieces held away from your face so that you avoid inhaling the dust.



# OWNER GUIDE

- We do not recommend the use of a normal domestic vacuum cleaner that may blow dust back into the air.
- We suggest that you remove the ceramic fuel effect pieces in the reverse order to that shown in the installer and owner guide supplied with the ceramic fuel effect. This should have been placed inside or attached to this guide by the installer.

## **Burner.**

Remove any deposits of soot or other foreign matter from the the burner with a dry soft brush. Be careful not to brush any particles into the open holes. Remove any particles from the holes with a vacuum cleaner fitted with a soft brush attachment. **Do not poke wire, etc. into the holes in the burner.**

## CERAMIC FUEL EFFECT REFITTING

The installer and owner guide for the ceramic fuel effect is separate from this guide. The installer may have attached it to this guide or placed it inside. It is important that the installer and owner guide for the ceramic fuel effect is followed correctly. If replacing the ceramic fuel effect, where a new guide is supplied, follow the installer and owner guide supplied with the replacement fuel effect.

Keep the replacement installer and owner guide with this owner guide for future reference.

## MAINTENANCE

### **Regular maintenance.**

In order to achieve and maintain high levels of personal safety and performance efficiency, it is essential that the opening at the back of the fire and the flue are kept clear of any form of obstruction. It is possible that deposits of mortar or soot could fall and accumulate causing the flue to be blocked or restricted and so preventing proper clearance of dangerous exhaust fumes.

In the United Kingdom it is the law that a landlord must have any gas appliance, flue and pipework which is situated in a tenant's premises checked for safety at least every twelve months by a competent person (In the U.K, a CORGI registered installer).

We recommend that all gas appliances and their flues, wherever situated, are checked annually.

# OWNER GUIDE

## Servicing.

- In the United Kingdom servicing can be carried out either by a Baxi Fires Division service engineer or a CORGI registered installer.
- If you require your fire to be serviced, please contact **Baxi Fires Division Service** on **08706 090 081** and quote the following details;

## IMPORTANT

**To help us quickly help you, please try to have the following information available before you contact us:**

**Type of fire.**

**Model/Name.**

**Serial Number.**

**You will also be asked for the fault, problem or request plus your Post Code.**

- If you wish to replace any of the ceramic fuel effect pieces, spare parts are available nationwide via the ‘**interpart** stockist network’. For your local stockist consult Yellow pages under Central Heating.
- **When fitting replacement parts it is important that only approved parts are used for maximum safety.**

## USEFUL TELEPHONE NUMBERS

General advice about gas and your gas fire:

**BAXI FIRES DIVISION TECHNICAL HELPLINE      08706 061 065.**

To report faults or arrange for your fire to be serviced:

**BAXI FIRES DIVISION SERVICE      08706 090 081.**

For sales or product information:

**BAXI FIRES DIVISION SALES      08706 061 067.**

To order spares

**Spare parts are available nationwide via the ‘interpart stockist network’. For your local stockist consult Yellow pages under ‘Central Heating’.**

CALLERS IN THE REPUBLIC OF IRELAND

Call    **0044 8706 061 065**