

BAXI FIRES DIVISION

INSTALLER GUIDE

Model 941

INSET LIVE FUEL EFFECT GAS FIRE

Fitted with

Anthem, Blenheim, Bolero,

Camden, Minima, Sonnet,

Victorian or

Westminster fascia

(GC No. 32-811-21)

**THIS APPLIANCE IS FOR USE WITH NATURAL GAS (G20).
WHEN CONVERTED USING CONVERSION KIT NO. 0595211 THIS
APPLIANCE IS FOR USE WITH PROPANE GAS (G31).
THIS APPLIANCE IS SUITABLE ONLY FOR INSTALLATION IN THE UNITED
KINGDOM (GB) AND THE REPUBLIC OF IRELAND (IE).**

We trust that this guide gives sufficient details to enable this appliance to be installed and maintained satisfactorily. However, if further information is required, our

Baxi Fires Division Technical Helpline will be pleased to help.

Telephone **08706 061 065** (National call rates apply in the United Kingdom)

In the Republic of Ireland telephone **0044 8706 061 065**.

INSTALLER: Please leave this guide with the owner

BAXI ● VALOR ● WONDERFIRE

INSTALLER GUIDE

Safety First.

Baxi Fires Division fires are CE Approved and designed to meet the appropriate British Standards and Safety Marks.



Quality and Excellence.

All Baxi Fires Division fires are manufactured to the highest standards of quality and excellence and are manufactured under a BS EN ISO 9001 quality system accepted by the British Standards Institute.



The Highest Standards

Baxi Fires Division is a member of the Society of British Gas Industries which works to ensure high standards of safety, quality and performance.



Careful Installation

Baxi Fires Division is a CORGI registered company. All our gas fires must be installed by a competent CORGI Registered Installer in accordance with our Installer Guide and should not be fitted directly on to a carpet or floor of combustible material.

B A X I F I R E S D I V I S I O N

Baxi Fires Division, Erdington, Birmingham B24 9QP
www.firesandstoves.co.uk

Because our policy is one of constant development and improvement, details may vary slightly from those given in this publication

INSTALLER GUIDE

CONTENTS

<u>Section</u>	<u>Heading</u>	<u>Page</u>
1.	SAFETY	4
2.	APPLIANCE DATA	5
3.	GENERAL INSTALLATION REQUIREMENTS	6
4.	PACK CONTENTS	13
5.	FIREPLACE CHECK	17
6.	IGNITION CHECK	19
7.	GAS SUPPLY CONNECTION	19
8.	PREPARING APPLIANCE FOR INSTALLATION	20
9.	HOTBOX INSTALLATION	22
	9.1 Method 1 - Front fixing to fireplace surround.	22
	9.2 Method 2 - Cable retention and floor fixing.	22
	9.3 Sealing floor front - All installations.	24
10.	BURNER & SUPPLY PIPE INSTALLATION	25
	10.1 Burner and supply pipe installation.	25
	10.2 Preliminary burner checks.	25
	10.3 Inlet pressure check.	26
11.	CERAMIC WALLS INSTALLATION	26
12.	FITTING THE FASCIA	27
13.	FITTING THE CERAMIC COAL FUEL EFFECT	29
14.	FITTING THE CERAMIC PEBBLE FUEL EFFECT	34
15.	FITTING THE FIREFRONT	38
16.	FULL OPERATING CHECKS	40
	16.1 Check the control settings.	40
	16.2 Check for spillage.	41
	16.3 Flame supervision and spillage monitoring system.	41
17.	FINAL REVIEW	42
18.	SERVICING & PARTS REPLACEMENT	43
	18.1 Checking the aeration setting of the burner.	44
	18.2 To remove the Westminster and Bolero fascia.	44
	18.3 To remove the Victorian fascia.	44
	18.4 To remove the Anthem, Camden and Minima fascia.	45
	18.5 To remove the complete burner unit.	45
	18.6 To remove the pilot unit.	45
	18.7 To remove the gas valve.	46
	18.8 To remove the piezo generator.	46
	18.9 To grease the control tap.	46
	18.10 To replace the burner.	47
	18.11 To remove the main burner injector.	47
	18.12 To remove the appliance from the fireplace.	47

INSTALLER GUIDE

1. SAFETY

Installer

Before continuing any further with the installation of this appliance please read the following guide to manual handling:

- The lifting weight of this appliance is as below:

<u>Model</u>	<u>Heat Engine (kg)</u>	<u>Fascia / Firefront (kg)</u>	<u>Combined Weight (kg)</u>
Anthem	4.9	2.01	6.91
Blenheim	4.9	3.86	8.76
Bolero	4.9	13.35	18.25
Camden	4.9	0.71	5.61
Minima	4.9	1.16	6.06
Sonnet	4.9	3.86	8.76
Victorian	4.9	5.23	10.13
Westminster	4.9	9.56	14.46

- One person should be sufficient to lift the fire. If for any reason this weight is considered too heavy then obtain assistance.
- When lifting always keep your back straight. Bend your legs and not your back.
- Avoid twisting at the waist. It is better to reposition your feet.
- Avoid upper body/top heavy bending. Do not lean forward or sideways whilst handling the fire.
- Always grip with the palm of the hand. Do not use the tips of fingers for support.
- Always keep the fire as close to the body as possible. This will minimise the cantilever action.
- Use gloves to provide additional grip.
- Always use assistance if required.

INSTALLER GUIDE

2. APPLIANCE DATA

This product uses fuel effect pieces and burner compartment walls containing Refractory Ceramic Fibres (RCF), which are man-made vitreous silicate fibres. Excessive exposure to these materials may cause irritation to eyes, skin and respiratory tract. Consequently, it is important to take care when handling these articles to ensure that the release of dust is kept to a minimum. To ensure that the release of fibres from these RCF articles is kept to a minimum, during installation and servicing we recommend that you use a HEPA filtered vacuum to remove any dust and soot accumulated in and around the fire before and after working on the fire. When replacing these articles we recommend that the replaced items are not broken up, but are sealed within a heavy duty polythene bag, clearly labelled as RCF waste. This is not classified as “hazardous waste” and may be disposed of at a tipping site licensed for the disposal of industrial waste. Protective clothing is not required when handling these articles, but we recommend you follow the normal hygiene rules of not smoking, eating or drinking in the work area and always wash your hands before eating or drinking. This appliance does not contain any component manufactured from asbestos or asbestos related products.

Gas	Natural (G20)	Propane (G31) *
Inlet Pressure	20mbar	37mbar
Input - Max. (Gross)	6.8kW (23,400 Btu/h)	6.7kW (22,860 Btu/h)
Input - Min. (Gross)	2.3kW (7,850 Btu/h)	4.0kW (13,650 Btu/h)
Inlet Test Pressure (Cold)	20.0 ± 1.0mbar (8.0 ± 0.4in w.g.)	37.0 ± 1.0 mbar (14.85 ± 0.4in w.g.)
Gas Connection	8mm pipe	8mm pipe
Burner Injector	Stereomatic Cat 82 - 074	Stereomatic Size 132
Pilot & Atmosphere Sensing Device	Copreci Ref. O.D.S 21500/166	Copreci Ref. O.D.S 21500/166 Fitted with RBM 180 -02 injector
Ignition	Integral piezo (Mounted on gas valve)	Integral piezo (Mounted on gas valve)
Aeration	See section 18.1	Non-adjustable

*When converted using kit 0595211.

The appliance data label is located on a plate at the base of the fire. This can be seen by removing the firefront casting / firefront.

INSTALLER GUIDE

3. GENERAL INSTALLATION REQUIREMENTS

3.1 The installation must be in accordance with these instructions.

For the user's protection, in the United Kingdom it is the law that all gas appliances are installed by competent persons in accordance with the current edition of the Gas Safety (Installation and Use) Regulations. Failure to install the appliance correctly could lead to prosecution. The Council for the Registration of Gas Installers (CORGI) requires its members to work to recognised standards.

In the United Kingdom the installation must also be in accordance with:

All the relevant parts of local regulations.

All relevant codes of practice.

The relevant parts of the current editions of the following British Standards:-

BS EN 1856 Part 1 which replaces BS 715

BS EN 1858 which replaces BS 1289 Part 1

BS EN 1806 which replaces BS 1289 Part 2

BS EN 1856 Part 1 which replaces BS 4543 Part 2

BS 5440 Part 1

BS 5440 Part 2

BS 6461 Part 1

BS 1251

BS EN 1806

BS 5871 Part 2

BS 6891

BS 8303

In England and Wales, the current edition of the Building Regulations issued by the Department of the Environment and the Welsh Office

In Scotland, the current edition of the Building Standards (Scotland) Regulations issued by the Scottish Executive.

In Northern Ireland, the current edition of the Building regulations (Northern Ireland) issued by the Department of the Environment for Northern Ireland.

In the republic of Ireland the installation must be carried out by a competent person and also conform to the relevant parts of:

- a) The current edition of IS 813 "Domestic Gas Installations"
- b) All relevant national and local rules in force.

Where no specific instructions are given, reference should be made to the relevant British Standard Code of Practice.

3.2 In the United Kingdom, as supplied, the appliance can be installed in the following situations: -

3.2.1 To a fireplace complete with surround and hearth as shown in figure 1 and

INSTALLER GUIDE

complying with BS1251 after removal of the fireback and sufficient material behind the fireback for a debris catchment space. The required fireplace, hearth, debris catchment area and clearance dimensions are shown in figure 1.

3.2.1.1 'Hole-in-the-wall' Installations

- It is recommended that a hearth should be installed as in section 3.9 (See figure 1).

- If a reduced depth hearth is fitted, the fire

must be installed so that the distance from the base of the fireplace opening in the wall to the finished floor level is at least 100mm. Where there is no floor covering or carpet and the floor is of a type that is likely to be covered in such a way in the future then the distance from the base of the fireplace opening in the wall to the floor level should be increased to at least 175mm.

- To protect from the risk of burns and ignition of clothing a tactile separator shall be used. The hearth detailed in section 3.9 meets the requirements for a tactile separator. If this is not used then a 672mm long fender, kerb, horizontal bar, or other barrier, being fixed not less than 50mm above floor level and positioned 300mm in front of the fixing plane of the fire will meet the requirement.

- If the lower part of the fascia (the firefront) is free standing, the recommended reduced hearth depth is 100mm. This is necessary to support the firefront (See figure 5 for appliance dimensions).

3.2.2 To a fireplace incorporating a metal flue box complying with the constructional requirements of the current edition of BS EN 1856 Part 1 or BS715. The dimensions of the flue box must conform to those shown in figure 2.

3.2.3 To a precast concrete or clay flue block system conforming to BS1289 or BS EN 1806 with dimensions as in figure 3. The current versions of BS1289 and BS EN 1806 recommend that there should be an air space or insulation between the flue blocks and the plaster because heat transfer may cause cracking on directly plastered flues.

However, generally this appliance is suitable for installations under all circumstances unless there is a history of cracking problems.

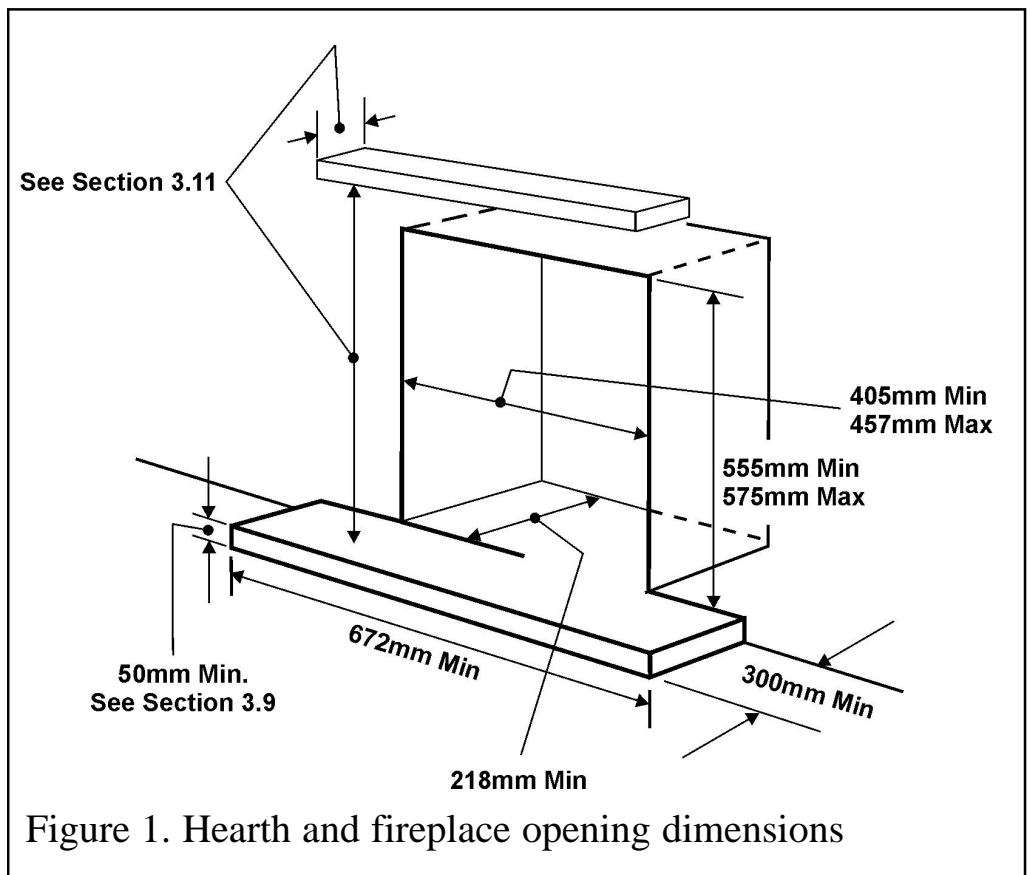

INSTALLER GUIDE

Remember that faults such as cracking may be caused by poorly built and restrictive flues, e.g. mortar extrusions, too many bends, flue heights below three metres, restrictive terminations etc.

3.2.4 If the fireplace opening is greater than the acceptable dimensions given in this guide, do not use the back of a fire surround or marble to reduce the opening. This may cause cracking of the surround back or marble.

3.3 Suitable flues and minimum flue sizes are as follows: -

It should be noted that, as with many appliances, sharp bends

or horizontal runs in metal flues at the top of the system can be a cause of problems in these types of installation.

- 225mm x 225mm conventional brick flue.
- 175mm diameter lined brick or stone flue.
- 200mm diameter factory made insulated flue manufactured to BS4543.
- 175mm diameter flue pipe. See BS6461 Part 1 for suitable materials.
- Single wall, twin wall or flexible flue liner with a minimum diameter of 125mm. The materials to be used are stainless steel or aluminium as specified in BS EN 1856 Part 1 or BS715. The liner must be sealed to the surrounding area above the fireplace opening and to the top of the chimney. An approved terminal must be fitted.
- A properly constructed precast concrete or clay flue system conforming to BS1289 or BS EN 1806. This system is only suitable if the conditions stated in section 3.2.3 are met.

3.4 The flue must conform to BS 5440: Part 1 in design and installation.

The flue, measured from the bottom of the fireplace opening to the bottom of the terminal, shall be not less than 3m in actual vertical height. When calculated in accordance with BS 5440: Part 1 Annex A, the minimum **equivalent** height of the flue shall be 2.0m of 125mm dia. flue pipe.

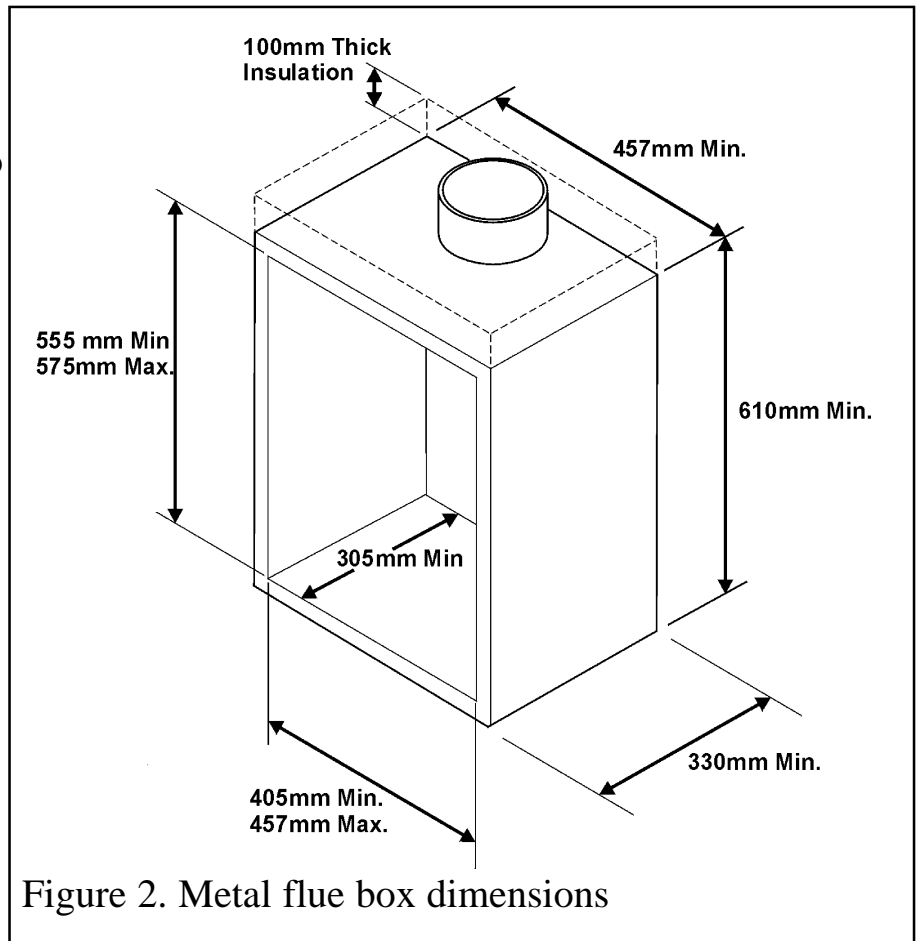

Figure 2. Metal flue box dimensions

INSTALLER GUIDE

3.5 The flue must not be used for any other appliance or application.

3.6 Any chimney damper or restrictor should be removed. If removal is not possible, they must be secured in the open position.

3.7 If the appliance is intended to be installed to a chimney that was previously used for solid fuel, the flue must be swept clean prior to installation. All flues should be inspected for soundness and freedom from blockages.

3.8 If the fireplace opening is an underfloor draught type, it must be sealed to stop any draughts.

3.9 The appliance must be mounted behind a non-combustible hearth (N.B. conglomerate marble hearths are considered as non-combustible) unless the conditions of section 3.2.1.1 are met. The appliance can be fitted

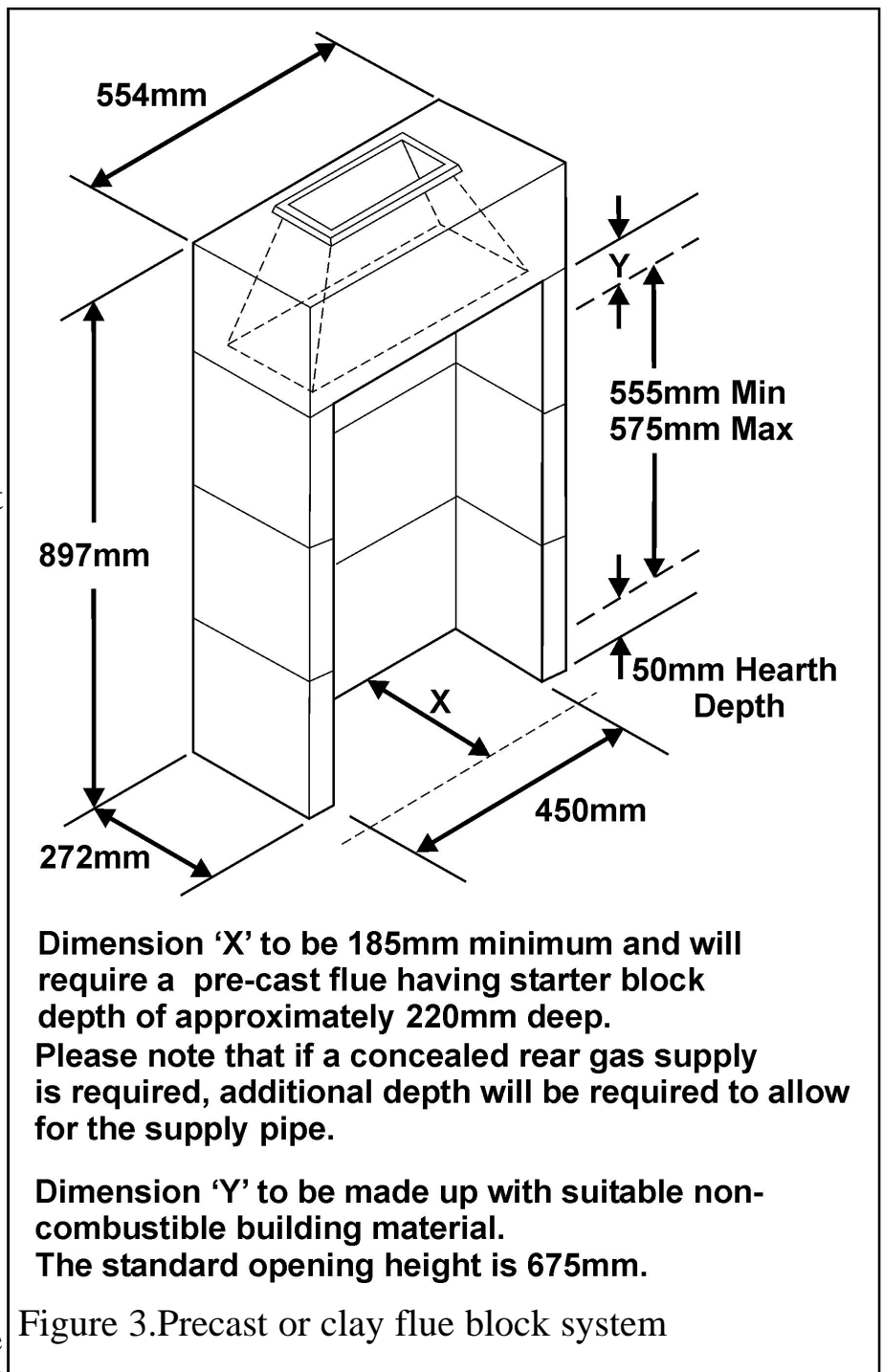

to a purpose made proprietary class "O"-150°C surround. The hearth material must be at least 12mm thick. The periphery of the hearth (or fender) should be at least 50mm above floor level to discourage the placing of carpets or rugs over it.

The surface of the hearth must be sufficiently flat to enable the bottom of the front surround and the bottom front cover to be aligned horizontally. Any excessive unevenness (uneven tiles, Cotswold stone, etc.) should be rectified. The appliance must not stand on combustible materials or carpets.

INSTALLER GUIDE

3.10 The front face of the fireplace should be reasonably flat over the area covered by the hotbox top and side flange seals to ensure good sealing. These faces should be made good if necessary. The fireplace floor should be reasonably flat to ensure that a good seal with the hotbox can be made.

3.11 The minimum height from the base of the fireplace opening to the underside of any shelf made from wood or other combustible materials is detailed below.

- For a shelf up to 150mm deep: Minimum height = 760mm.
- For a shelf deeper than 150mm: 760mm + 12.5mm for every 25mm depth over 150mm (See Graph 1).

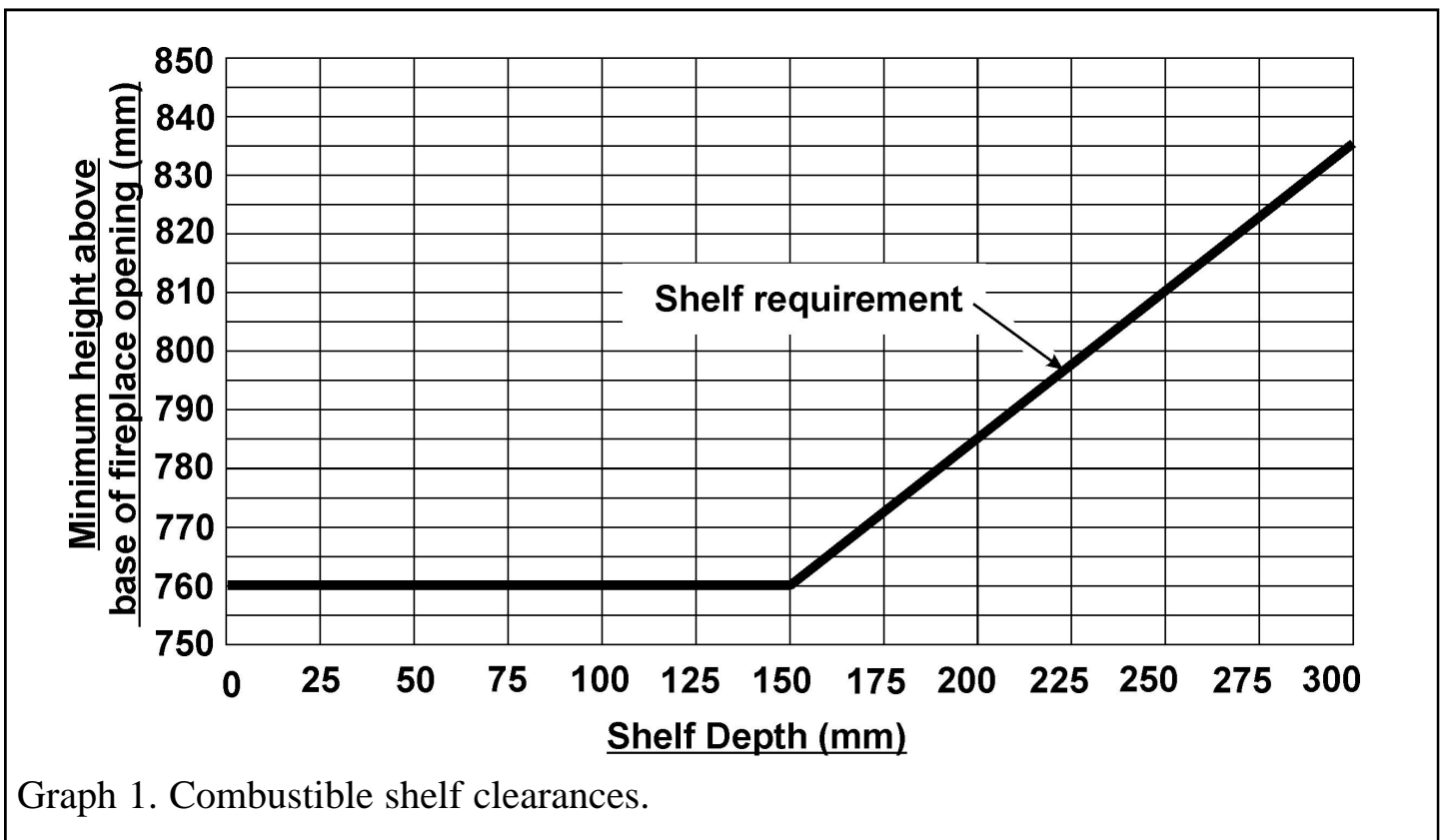

3.12 Note that soft wall coverings (e.g. embossed vinyl, etc.) are easily affected by heat. They may scorch or become discoloured when close to a heating appliance. Please bear this in mind when installing.

3.13 This appliance must not be installed in any room that contains a bath or shower or where steam is regularly present.

3.14 An extractor fan may only be used in the same room as this appliance, or in any area from which ventilation for the appliance is taken, if it does not affect the safe performance of the appliance. Note the spillage test requirements detailed further on in this manual. If the fan is likely to affect the appliance, the appliance must not be installed unless the fan is permanently disconnected.

INSTALLER GUIDE

3.15 Normal adventitious ventilation is usually sufficient to satisfy the ventilation requirements of this appliance. In GB reference should be made to BS 5871 Part 2 and in IE reference should be made to the current edition of IS 813 “Domestic Gas Installations” which makes clear the conditions that must be met to demonstrate that sufficient ventilation is available.

3.16 Propane gas appliances must not be installed in a room that is built entirely below ground level (See BS 5871 Part 2).

3.17 If the appliance is to be fitted against a wall with combustible cladding, the cladding must be removed from the area covered by the fascia. The cladding must also not touch the fascia (See figure 4). We suggest that the fascia is used as a template to mark the area for combustible cladding removal and that this area is increased by at least 2mm all round.

3.18 The minimum allowable distance from the outside of the appliance fascia to a corner wall having combustible material or any other combustible surface which projects beyond the front of the appliance is shown in figure 5.

3.19 Proprietary terminals must comply with BS 715 or BS 1289. Any terminal or

termination must be positioned in accordance with BS 5440 Part 1 to ensure that the products of combustion can be safely dispersed into the outside atmosphere. Where the appliance is connected to an unlined brick chimney it is generally unnecessary for the chimney pot to be replaced or for a terminal to be fitted unless the flue has a diameter smaller than 170mm.

3.20 The appliance is fitted with an A.S.D (Atmosphere sensing device). If the appliance closes down after a period of operation for no apparent reason, the consumer should be informed to stop using the appliance until the installation and appliance have been thoroughly checked. The A.S.D will shut the appliance down if an unacceptable amount of harmful products of combustion accumulate. Under no circumstances should the A.S.D be altered or bypassed in any way. Only a genuine manufacturers replacement part should be fitted. The individual A.S.D components are not replaceable.

3.21 A fireguard complying with BS 8423 should be fitted for the protection of young children, the elderly, or the infirm.

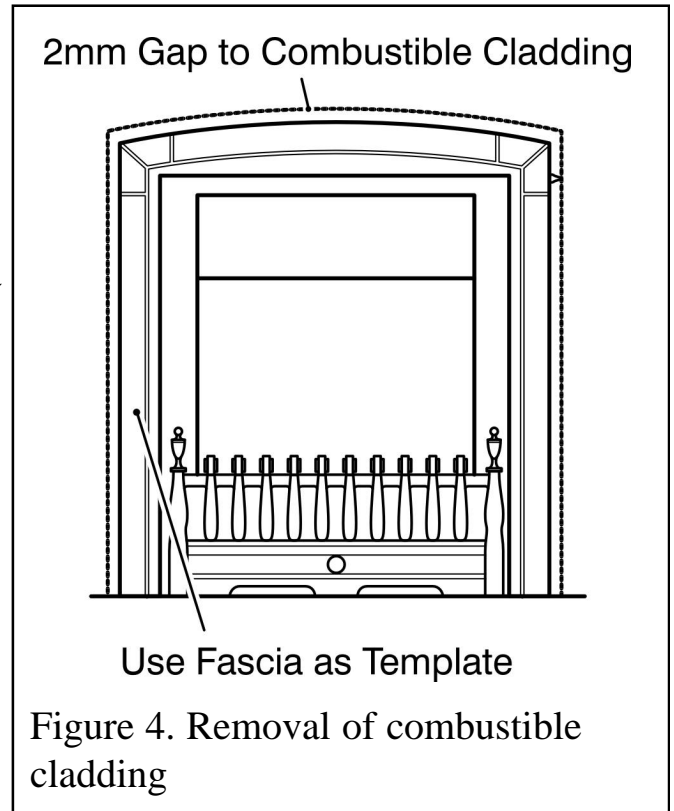

INSTALLER GUIDE

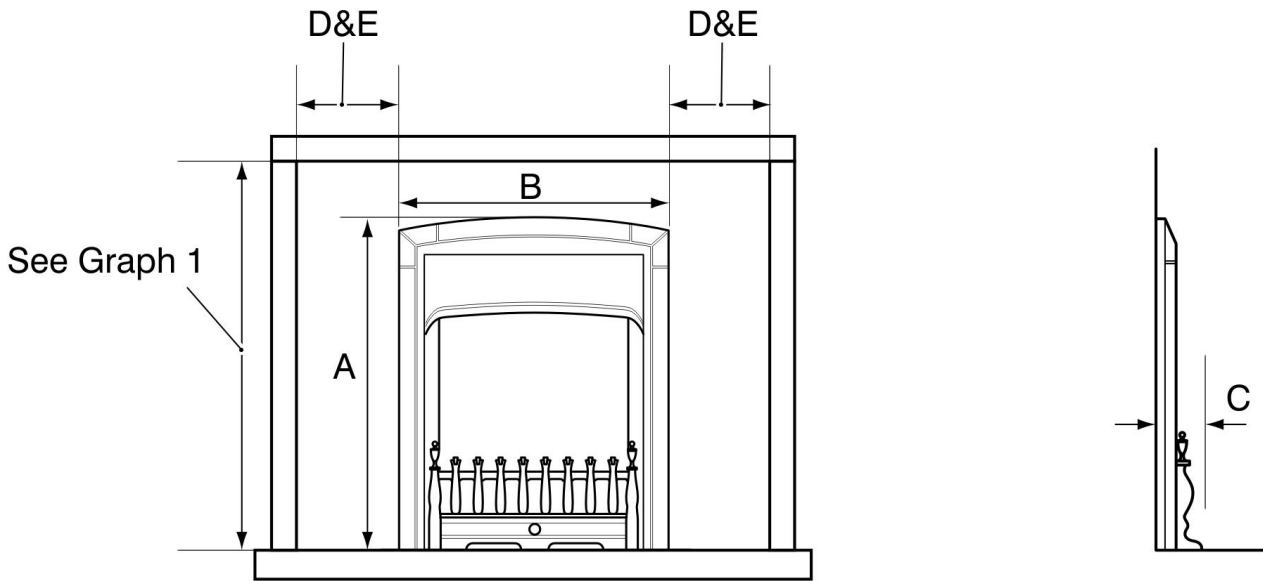

Key	Description	Model					
		Bolero	West-minster	Victorian	Anthem & Camden	Sonnet & Blenheim	Minima
A	Appliance height (mm)	636	605	612	599	599	599
B	Appliance width (mm)	518	500	515	492	492	492
C	Appliance depth into room (mm)	94	50	70	71	65	75
D	Minimum mandatory clearance to combustible surfaces projecting beyond the front of appliance (mm).	108	100	100	125	125	125
E	Recommended clearance to non-combustible surfaces for access purposes (mm).	10	10	10	10	10	10

Figure 5. Appliance dimensions and clearances (Dimensions are subject to manufacturing deviation. Fascia may differ from that shown).

INSTALLER GUIDE

4. PACK CONTENTS

The items required for this appliance are packed in two sections.

Remove all the items carefully to prevent damage. Take special care when handling the ceramic components. Some items may be contained in the packaging fittings - Examine the packaging carefully before discarding. Check that all the items are present and undamaged.

Items below with a letter reference are supplied on a film wrapped card.

Section 1 - Fire Unit contains:

(See figure 6).

- 1 Burner and hotbox unit.
- 2 'A' Small "U" seals for hotbox side flanges.
- 9 'B' screws (No. 8 x 10).
- 2 'C' screws (M4 x 10).
- 2 'D' washers (For fascia hanging Bolero).
- 2 'E' screws (M4 x 25) (For fascia hanging on Bolero and Westminster only).
- 6 'F' Wall fixing plugs.
- 1 'G' Inlet elbow including pressure test point, nut and olive.
- 4 'H' Woodscrews
- 1 'K' Grommet.
- 2 'L' Cable adjusters.
- 4 'M' Eyescrews.
- 1 Burner front baffle (Supplied with all models but only required on Blenheim, Bolero, Camden, Sonnet and Victorian models only).
- 1 Flue restrictor plate.
- 1 Ceramic back wall.
- 1 Pair of ceramic side walls.
- 1 Ceramic fuel effect pack.
- 1 Strip of floor sealing tape.
- 2 Fire retaining cables.
- 1 Smoke match tube.
- 1 Rear ceramic wall support bracket.
- 1 Length of self adhesive foam seal.
- 1 Battery
- 1 Literature pack.

INSTALLER GUIDE

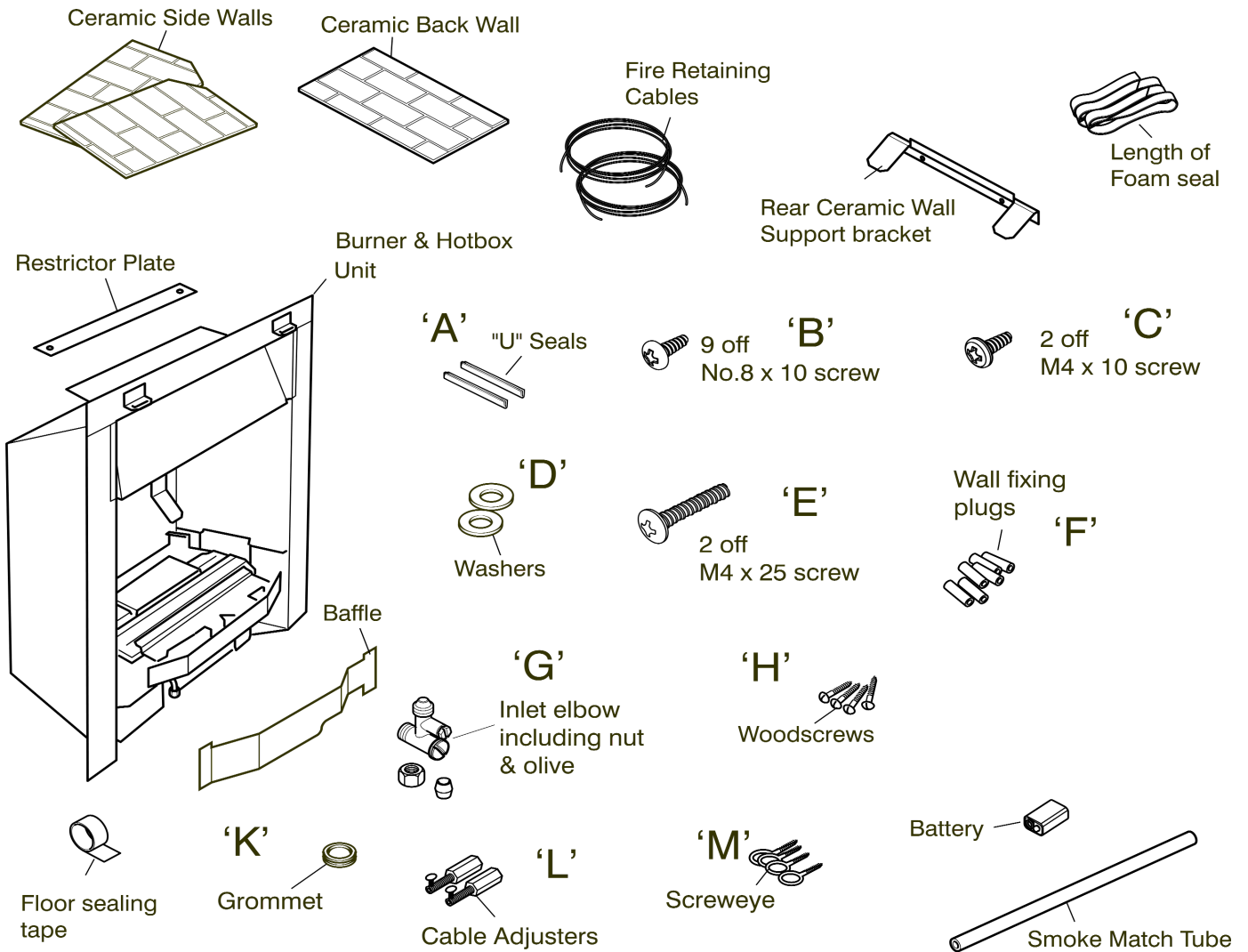

'Moulded' coal fuel effect
for use with:
Victorian,
Westminster,
Blenheim,
Sonnet &
Bolero)

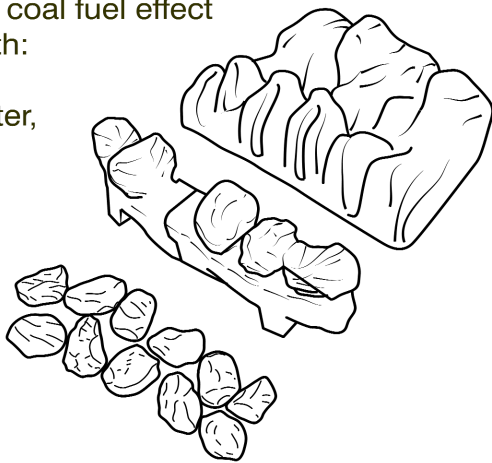

Pebble fuel effect
for use with:
Anthem, Camden &
Minima

12 pebbles

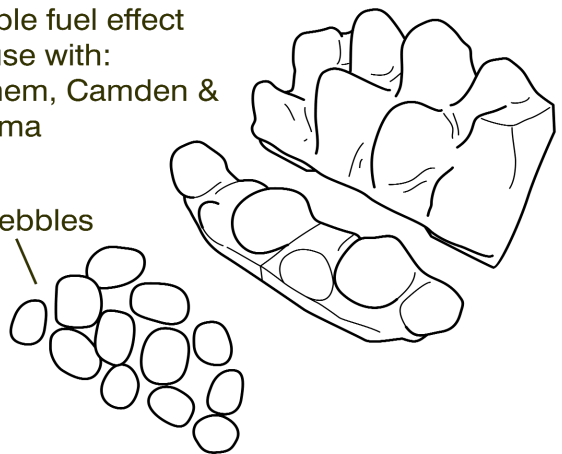

Figure 6. Pack contents

INSTALLER GUIDE

Section 2 - Bolero:

- 1 Fascia
- 1 Firefront casting
- 1 Bottom front cover casting.

Section 2 - Sonnet and Blenheim:

- 1 Fascia trim pack (Contains three separate pieces and six magnets)
- 1 Firefront casting
- 1 Bottom front cover casting.

Section 2 - Anthem:

- 1 Fascia trim pack (Contains three separate pieces and six magnets)
- 1 Firefront casting
- 1 Bottom front cover casting.

Section 2 - Victorian:

- 1 Fascia
- 1 Firefront casting
- 2 Finials
- 1 Bottom front cover casting
- 1 Spillage plate cover and four magnets

Section 2 - Westminster:

- 1 Fascia
- 1 Firefront casting
- 1 Bottom front cover casting

Section 2 - Camden & Minima:

- 1 Fascia trim pack (Contains three separate pieces and six magnets)
- 1 Firefront

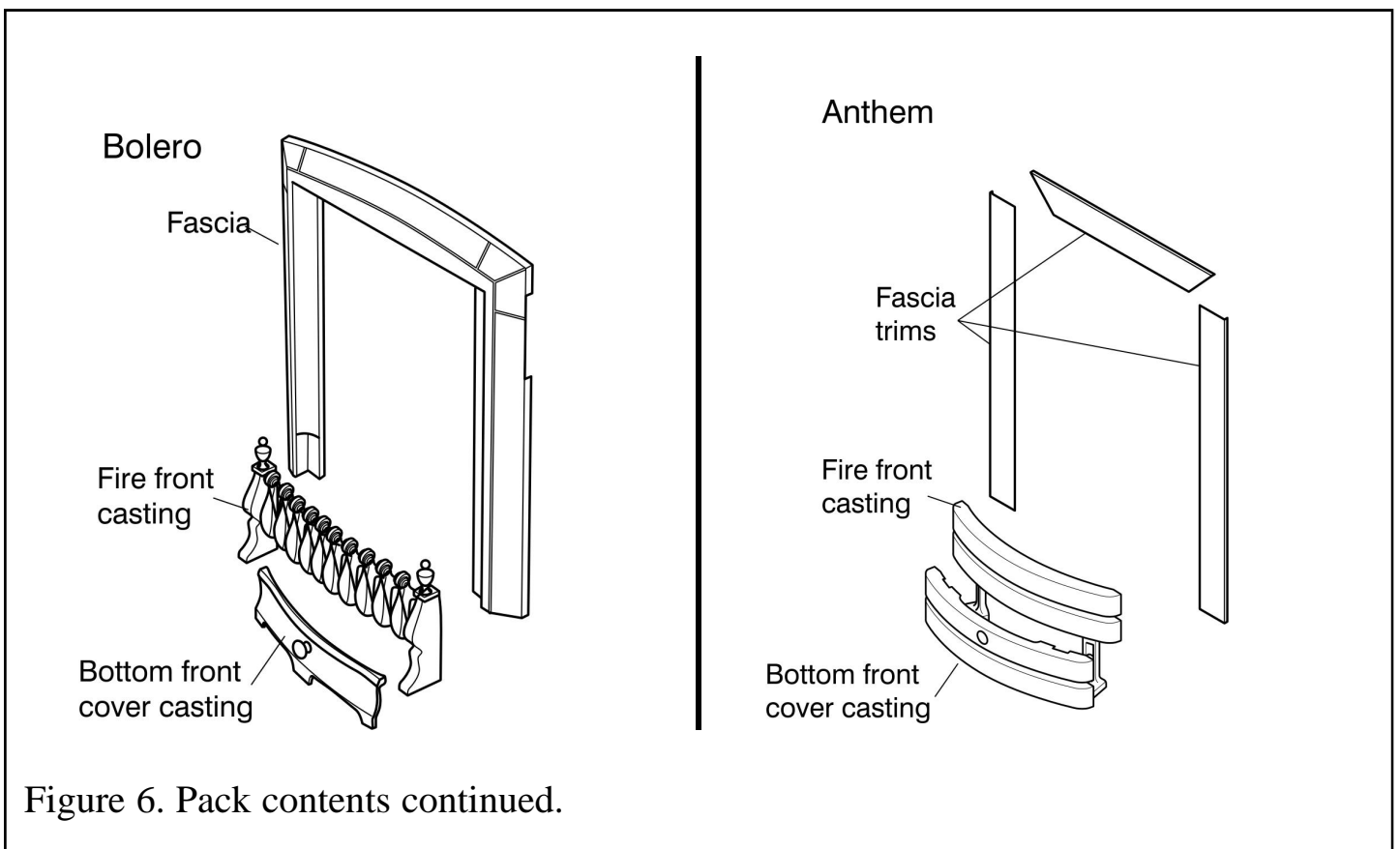
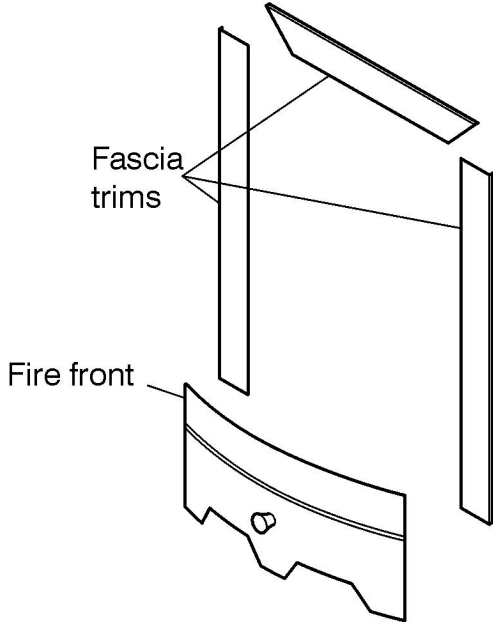

Figure 6. Pack contents continued.

INSTALLER GUIDE

Camden



Victorian

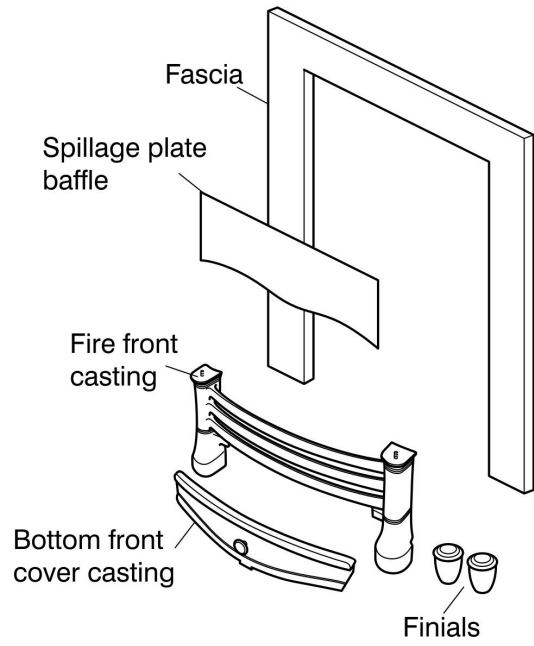

Westminster

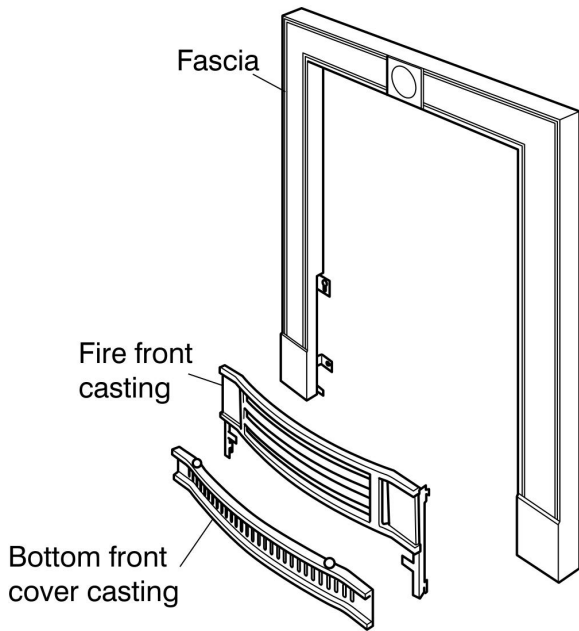

Minima

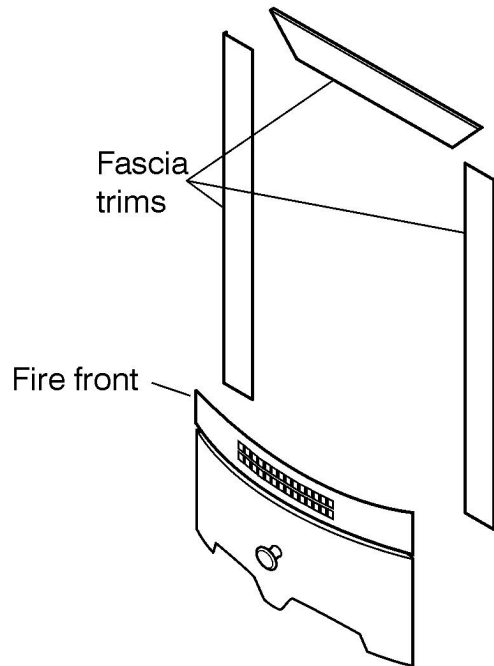
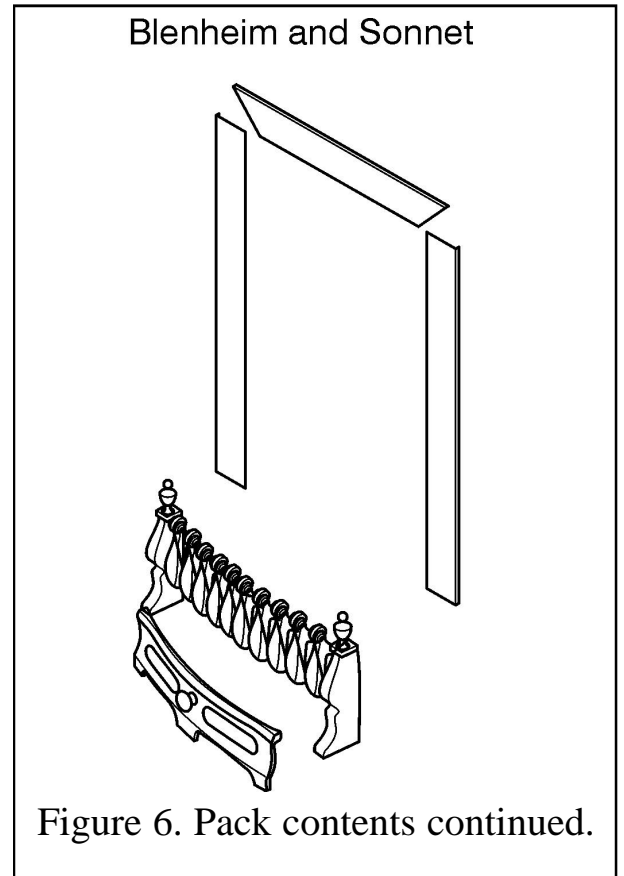

Figure 6. Pack contents continued.

INSTALLER GUIDE



5. FIREPLACE CHECK

5.1 Fireplace check.

5.1.1 Fireplace size

The fireplace must comply with the requirements described in section 3.2. This will probably entail removing the fireback and infill material behind the fireback. The debris catchment area shown in figure 7 must be kept clear of obstructions.

5.1.2 Fireplace general condition

The fireplace floor should be reasonably flat to ensure that the hotbox can be installed without it rocking and so that a good seal can be made at the bottom front of the box. The front face of the fireplace should be reasonably flat over the area covered by the hotbox top and side flange seals to

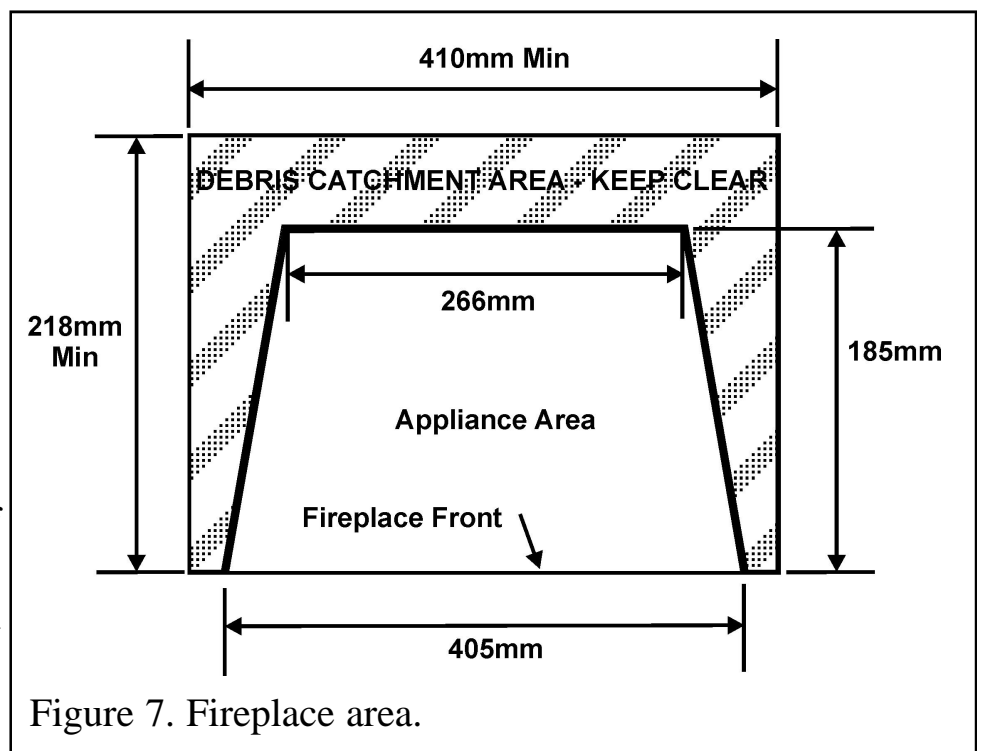

INSTALLER GUIDE

ensure good sealing. These faces should be made good if necessary. If the appliance is to be fitted against a wall with combustible cladding, the cladding must be removed from the area covered by the fascia. The cladding must also not touch the fascia (See figure 4). We suggest that the fascia is used as a template to mark the area for combustible cladding removal and that this area is increased by at least 2mm all round.

5.1.3 Soundness for appliance attachment

Two primary methods of retaining the appliance are provided: -

- 1) By fixing to the fireplace front surround.
- 2) Using concealed tension cables fixed to the rear of the fireplace opening together with secondary fixing to the fireplace floor.

The methods are detailed in section 9 of this guide. Before selecting the retention method, consult with the customer. Method 2 is provided for instances where drilling holes in the front surface of the fireplace surround is unacceptable to the customer or otherwise impractical. *N.B. It is unwise to attempt to drill into marble without the proper tools and equipment.*

If method 1 is chosen, make sure that the front surround area is sound enough to take the wall plugs and wood screws . If necessary, make sound with a suitable cement.

If method 2 is chosen, make sure that the areas at the back and towards the centre of the fireplace floor are sound enough to take the eyescrews and wood screws . If these areas have deteriorated due to prolonged use, they should be made sound with a suitable cement.

5.1.4 Installations using a metal flue box

The whole of the top surface of the metal flue box must be covered with a minimum 100mm layer of mineral wool or equivalent insulation (See figure 2).

5.2 Fireplace flue pull.

Close all doors and windows in the room in which the appliance is to be installed. After confirming with a match that smoke is drawn into the flue, light a 13 gram smoke pellet and check that there is a definite flow through the flue. Verify outside that the smoke exits from one terminal only and that the termination is suitable. Observe, where possible, upstairs rooms and loft spaces for signs of escaping smoke indicating a defective flue. If there is not a definite flow warm the flue for a few minutes and repeat the smoke pellet test. If there is still no definite flow the flue may need remedial work – **Do not fit the appliance until there is a definite flow through the flue.**

INSTALLER GUIDE

6. IGNITION CHECK

Before attempting to install, it is worth checking that the ignition system performs satisfactorily.

Set the control knob to the off position.

Depress the control knob and rotate it anticlockwise to the pilot ignition position. A

'click' will be heard as the integral piezo operates. A spark should be seen between the electrode and pilot tip. If there is no spark check the following: -

- Ensure that the electrode lead is connected to the terminal at the base of the electrode.
- If the above is correct, check for damage to the electrode lead.

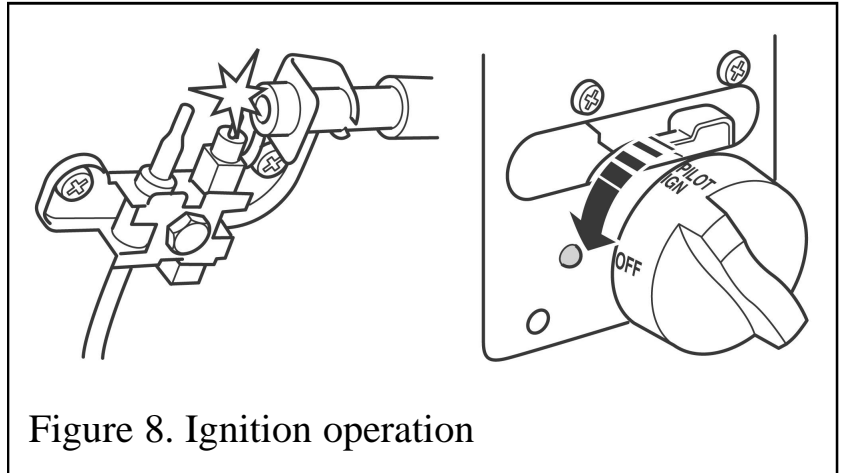

Figure 8. Ignition operation

7. GAS SUPPLY CONNECTION

A nut and olive are provided for an 8mm pipe inlet connection to the inlet elbow at the bottom front of the appliance. The elbow can be rotated to allow a connection from any direction. The elbow includes a valve for isolating the gas supply and a pressure test point.

The supply pipe must be rigid material. Flexible pipe must not be used.

Concealed supply pipe connection

If a concealed connection from inside the fireplace is required then, **before the appliance is fitted into the fireplace** it will be necessary to extend the supply line so that it will project through the hole in the back of the hotbox and run to the inlet elbow at the front. The pipe run from the supply line up to the rear opening in the hotbox must be kept away from the area which will be taken by the hotbox when it is installed (See figure 7).

Note that the centre of the appliance inlet elbow is 25mm above the fireplace floor. The inlet elbow 'G' should be fitted to the supply pipe at this stage.

INSTALLER GUIDE

8. PREPARING APPLIANCE FOR INSTALLATION

IMPORTANT

Before continuing with the installation of this gas fire the aeration setting on the burner must be checked. The aeration is factory set, but will require adjustment. See section 18.1 (Servicing and parts replacement).

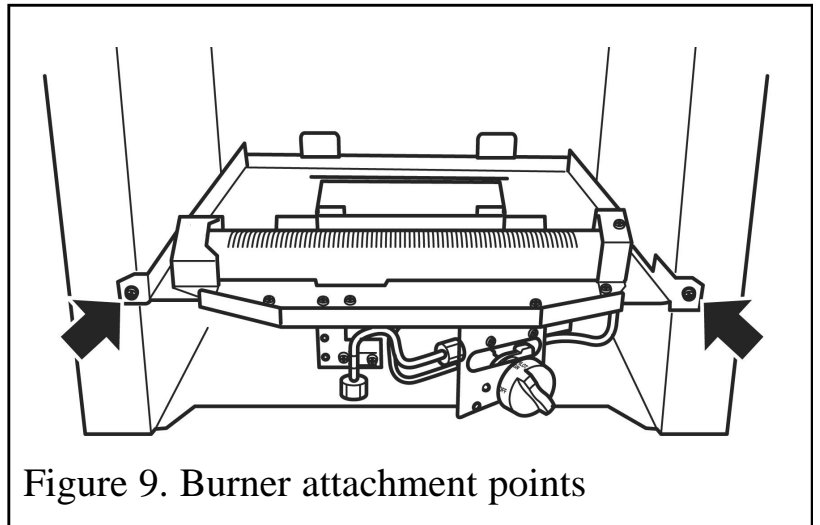

Figure 9. Burner attachment points

1. Detach the burner unit from the hotbox by removing two screws (See figure 9). Lift the burner unit clear.
2. Fit the two U- seals 'A' to the bottom edges of the hotbox side flanges (See figure 10).
3. It is important that the grommet 'K' supplied in the loose parts pack is fitted to the hole in the rear of the hotbox.

For concealed connection only:

4. Pierce the grommet to allow the pipe to pass through it. The grommet should envelop the pipe. If the hole is larger than the pipe, seal it with tape. **Do not pierce the grommet unless the supply pipe is to pass through it.**

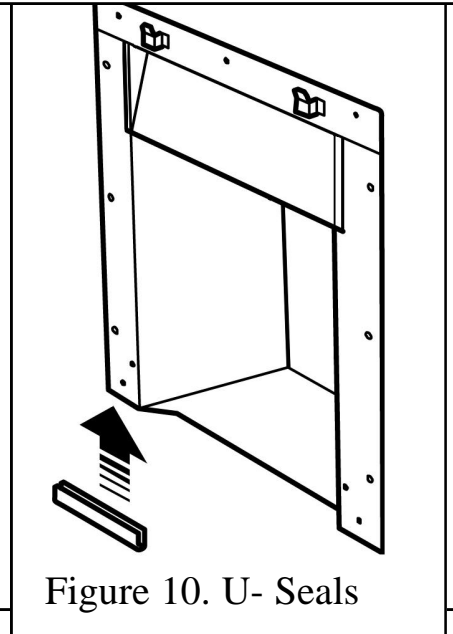

Figure 10. U- Seals

5. This appliance is supplied with a flue restrictor for use where the flue draught is excessive. The restrictor must NOT be fitted where a precast flue or a flue liner is used. For all other installations the restrictor should be fitted. There may however, be certain exceptional circumstances where fitting the restrictor causes the fire to fail the spillage test. In such cases the restrictor will have to be removed. After removal conduct the spillage check again.

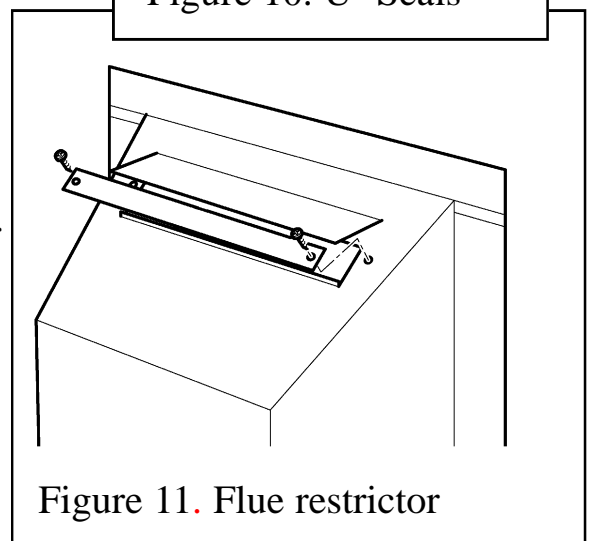

Figure 11. Flue restrictor

The restrictor is packed loose with the appliance and is fixed with two 'B' screws (See figure 11).

6. There is a length of self adhesive foam seal supplied with the fire. This will need to be fitted to the outer rear edges of the side and top flanges of the hotbox. Cut a 485mm

INSTALLER GUIDE

length of foam seal. Be careful not to stretch the seal when measuring. Remove the protective backing from the foam seal and fit this to the rear of the top flange (See figure 12). Cut two 580mm lengths. Fit these to the rear outer edges of the side flanges. Ensure that there is no gap between the foam seals where they meet at the top flange (See figure 12)

7. This appliance is supplied with a rear ceramic support bracket. Fit this using two 'B' screws supplied (See figure 13).

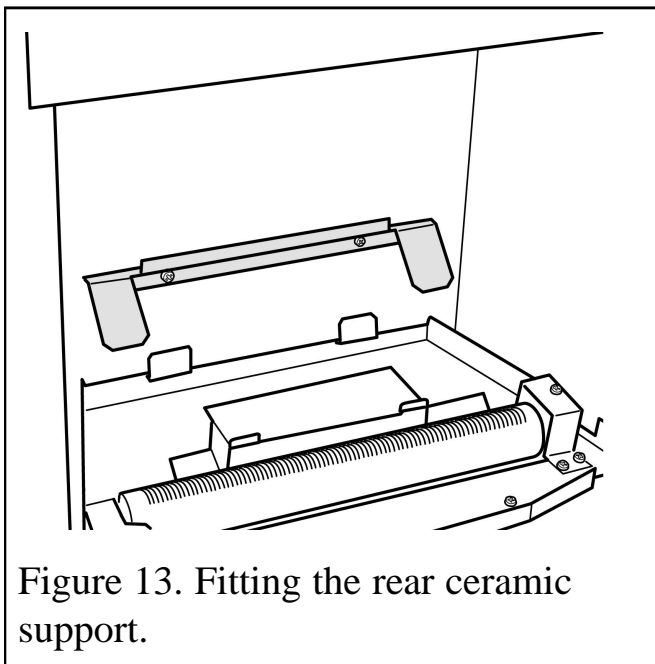

Figure 13. Fitting the rear ceramic support.

The Foam Seal should touch at this point. Ensure that there is no gap between the seals

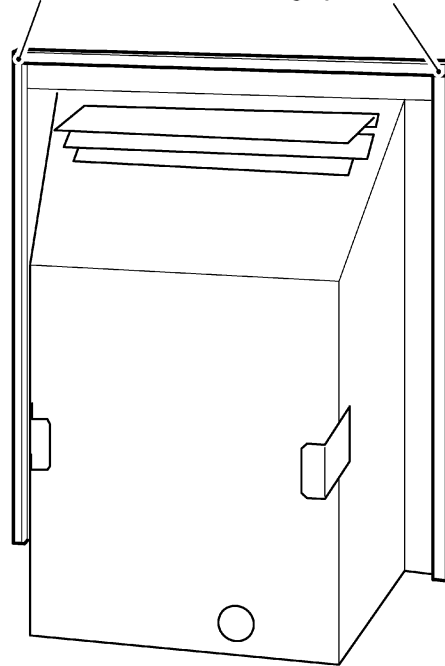

Figure 12. Fitting the foam seal

INSTALLER GUIDE

9. HOTBOX INSTALLATION

9.1 Method 1 - Front fixing to fireplace surround.

1. Make sure that the fireplace front surround area is sound enough to take the fibre wall plugs 'F' and wood screws 'H'. If necessary, make sound with a suitable cement.
2. Place the hotbox centrally in the fireplace in the position in which it is to be permanently installed. If a concealed connection is being used, insert the hotbox into the fireplace feeding the supply pipe through the pierced hole in the rear grommet.
3. Mark the fireplace front surround through the four fixing holes in the side flanges of the hotbox (See figure 14).

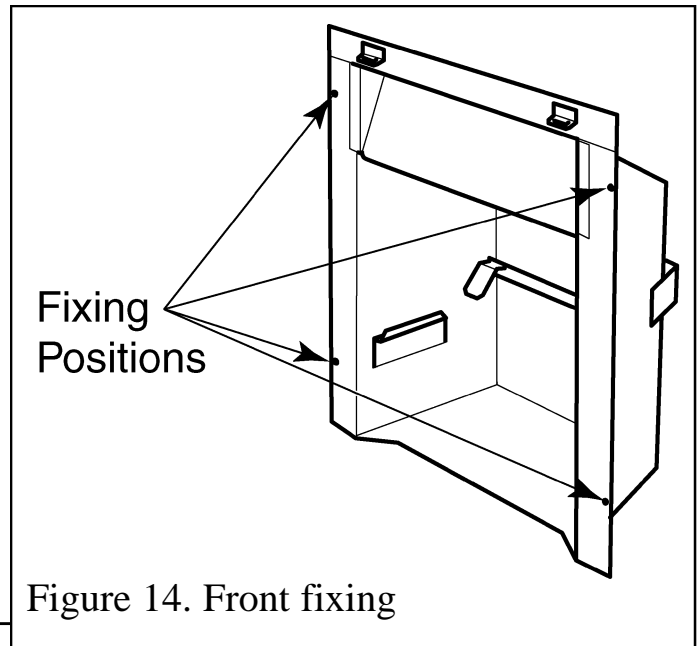

4. Remove the hotbox. Drill four holes in the fireplace front surround at the marked positions using a no.12 masonry drill.
5. Insert a fibre wall plug 'F' into each hole.
6. Place the hotbox back in position in the fireplace.
7. Fit a wood screw 'H' through each hole in the hotbox flanges and tighten to seal the box to the fireplace surround.

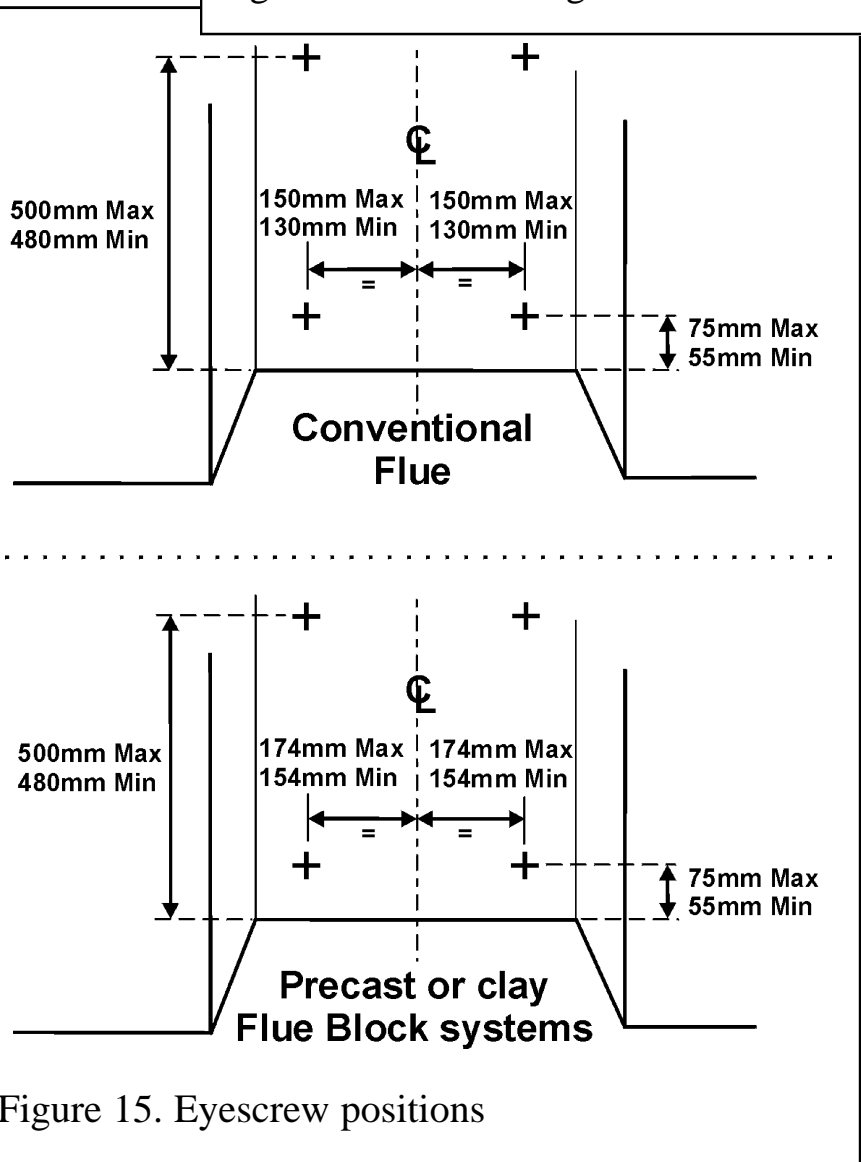

9.2 Method 2 - Cable retention and floor fixing.

1. Make sure that the relevant areas at the fireplace back or floor are sound enough to take the eyescrews 'M' and wood screws 'H'. If these areas have deteriorated due to prolonged use they should be made sound with a suitable cement.

INSTALLER GUIDE

2. Drill four holes in the rear wall of the fireplace for the fibre wall plugs 'F'. The holes should be drilled within the range of positions shown in figure 15 using a no.12 masonry drill. The holes should be equidistant each side of the centre line of the fireplace to ensure that the appliance finishes centrally in the opening when tension is applied to the cables.

3. Insert a fibre wall plug into each hole. Use the fibre plugs supplied with this appliance - **Never use plastic plugs instead of the fibre plugs supplied.** Screw the eyescrews 'M' into the plugs. Make sure that the eyescrews are secure.

4. Place the hotbox unit close to the fireplace but allow sufficient access into the fireplace opening so that the cables can be threaded through the eyescrews and returned through the back of the hotbox. If a concealed connection is being used, insert the hotbox into the fireplace feeding the supply pipe through the pierced hole in the rear grommet.

5. The hotbox has two holes at each side of the spillage plate. Insert one end of each cable (one cable each side) from the back through the lower of the two holes and return the end through the upper of the holes (See figure 16). Give the cables a pull so that they grip against the hotbox flanges.

6. Thread the cables through the eyescrews. Return the cables through the holes near the bottom of the hotbox back panel (See figure 17) (**For precast or clay block flue systems return the cables through the slotted holes in the side of the hotbox**).

7. Place the hotbox fully back into the fireplace opening so that it is sealed against the fireplace front surround.

8. Drill a hole into the fireplace floor through each of the two holes in the base of the hotbox using a no.12 masonry drill (See figure 18).

9. Insert a fibre wall plug into each hole. Fit a wood screw 'H' in each plug and tighten.

Always screw the base into position before applying tension to the cables. This will ensure a tight seal between the top of the hotbox and wall

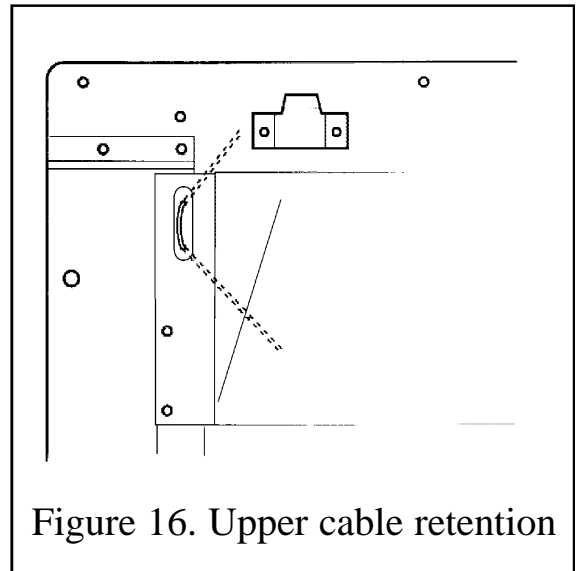

Figure 16. Upper cable retention

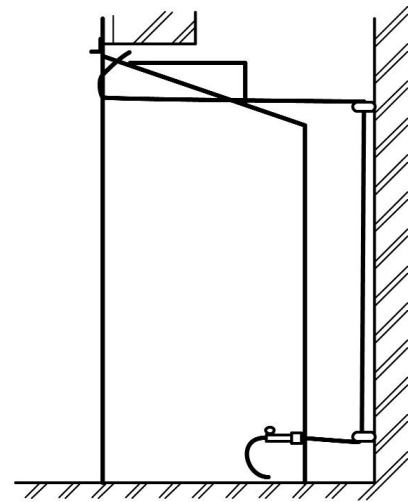

Figure 17. Cable route

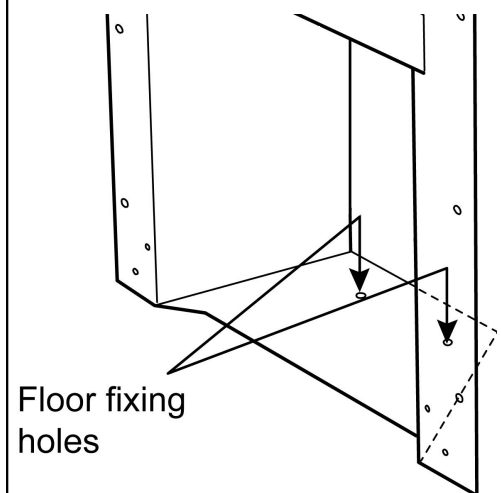

Figure 18. Floor fixing

INSTALLER GUIDE

10. Fit a cable adjuster 'L' over the bottom end of each cable.

11. Pull each cable taut. Push the cable adjusters hard up against the back panel. The end of the cable adjuster will pass into the hole. Tighten the screws in the adjusters so that they clamp the cables in position. Apply tension to the cables by turning the hexagonal adjusters by hand (See figure 19).

12. Inspect the installation of the hotbox against the fireplace surround. If the hotbox is aligned squarely and the sealing is satisfactory, fully tighten the cable adjusters.

13. If the hotbox is not correctly aligned, release the tension on the cables by slackening the screws and turning the hexagonal adjusters fully anticlockwise. The hotbox should then automatically realign itself. Pull each cable taut again and push the cable adjusters back against the back panel. Again, tighten the screws in the adjusters and apply tension to the cables by turning the hexagonal adjusters clockwise as far as possible.

14. Feed the free length of the cables into the gap between the inner and outer back panels so that they are available to allow easy removal and refitting of the appliance during subsequent service calls. **Do not cut off the free lengths of cable.** On precast flue installations feed the cables into the small holes at the base of the side panels (See figure 19)

9.3 Sealing floor front - All installations.

Using the floor sealing tape supplied, seal the bottom of the hotbox to the fireplace and hearth floor (See figure 20).

Make sure that the whole length of the front edge of the hotbox is fully sealed.

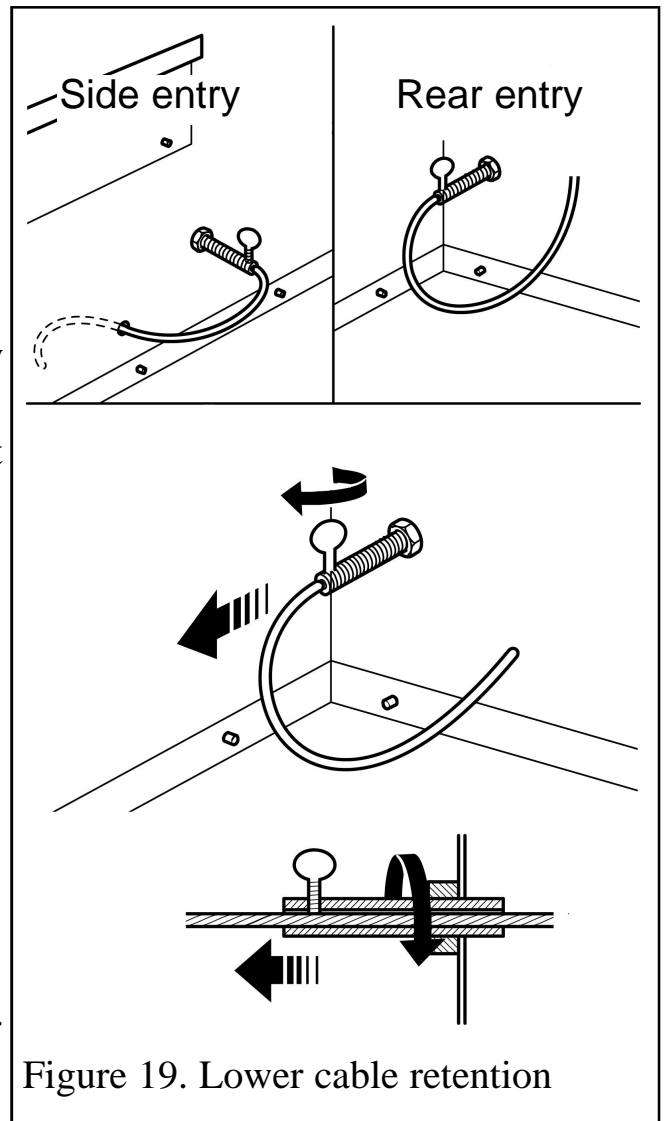

Figure 19. Lower cable retention

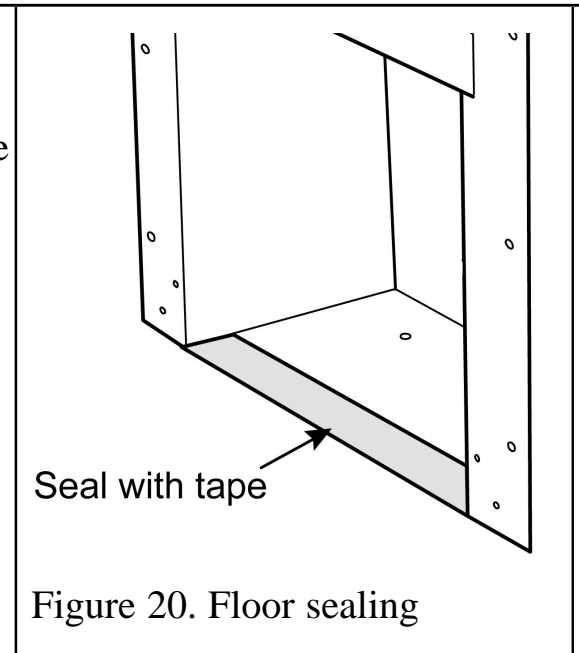

Figure 20. Floor sealing

10. BURNER & SUPPLY PIPE INSTALLATION

10.1 Burner and supply pipe installation.

1. Refit the burner unit to the hotbox with two screws.
2. Connect the supply line to the appliance.
3. Turn on the gas supply and pressure check the installation pipework for gas soundness. In the United Kingdom (GB) check in accordance with the current edition of BS 6891. In the Republic of Ireland check in accordance with the current edition of IS 813 “Domestic Gas Installations”.

10.2 Preliminary burner checks.

Some burner operations can be checked at this stage. Checking now will mean that less disassembly will be required if any problems are found. *A full check should still be made, however, after final installation.*

10.2.1 Lighting the burner.

1. If closed, open the isolating valve at the inlet elbow.
2. Depress the control knob and rotate it anticlockwise to the pilot ignition position. A 'click' will be heard as the integral piezo operates. A spark should be seen between the electrode and pilot tip.
3. Turn the control knob clockwise to the 'Off' position. Repeat this operation until a flame appears at the pilot. There may be a delay before the pilot lights due to air being purged from the system. When a flame appears at the pilot keep the control knob depressed and hold the pilot ignition position for five seconds. When the control knob is released the pilot flame should remain lit.

10.2.2 Operating the burner.

1. When the pilot burner is operating properly, gradually turn the control knob anti-clockwise to 'HIGH' (Depress the knob slightly to get past the pilot ignition position). The main burner should now light. Depress the control knob slightly to release from the 'HIGH' position and turn back (clockwise) to 'LOW'. While turning, the burner flames should gradually become lower but remain alight. Depress the control knob slightly to release from the 'LOW' position and turn back (clockwise) to the 'Pilot ignition' position. The main burner should extinguish but the pilot should remain alight. Depress the control knob slightly and turn back (clockwise) to turn OFF. This will extinguish the pilot.

If the above checks are satisfactory, continue with the installation. If not, check the control and ignition circuitry and components as described in the servicing section of this guide.

INSTALLER GUIDE

10.3 Inlet pressure check.

The appliance is pre-set to give the correct heat input at the inlet pressure shown in section 2 of this manual. No adjustment is necessary.

1. Check the inlet pressure by fitting a pressure gauge at the test point. The test point is on the inlet elbow (See figure 21). Check the pressure with the appliance alight and set at maximum output.
2. After checking, turn off the appliance. Remove the pressure gauge and replace the test point sealing screw.
3. Relight the appliance. Turn to the maximum output position and test around the sealing screw for gas soundness with a suitable leak detection fluid.

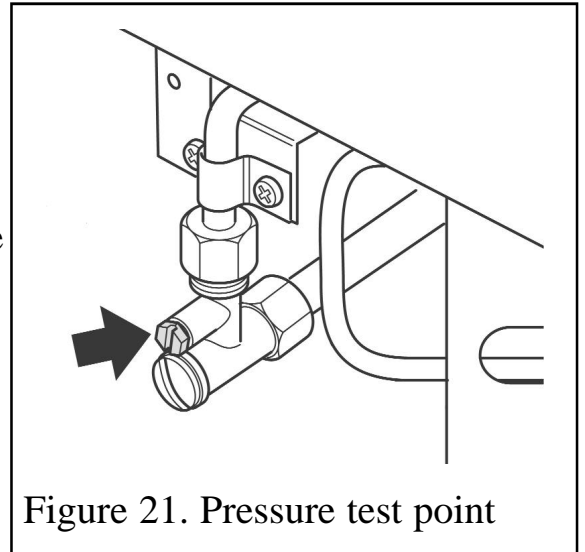

Figure 21. Pressure test point

When the above checks from section 10.2 and 10.3 have been completed close the isolating valve on the inlet elbow.

11. CERAMIC WALLS INSTALLATION

1. Fit the ceramic rear wall inside the “L” bracket on the back face of the burner compartment. Push the ceramic wall flat against the back face of the burner compartment (See figure 22).
2. Fit the ceramic side walls against the side faces of the burner compartment. The bottom edges of the walls should rest in the ledges at the sides of the firebox. Slide them in from the front and ensure that they touch the rear wall. Be careful not to damage the edges of the side walls (See figure 23).

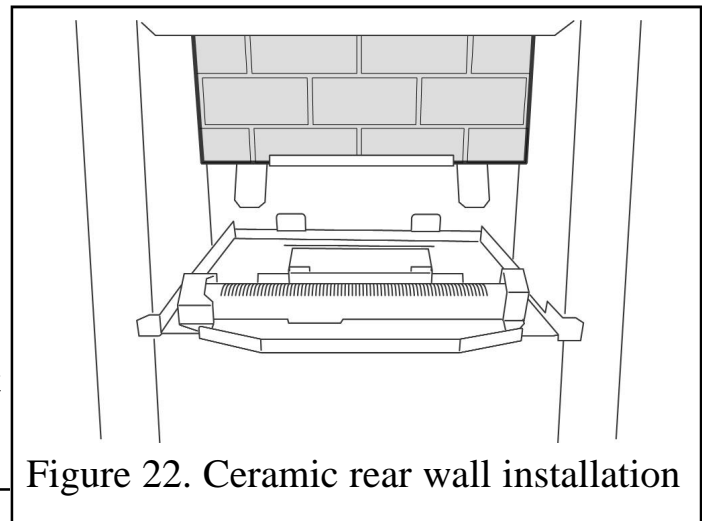

Figure 22. Ceramic rear wall installation

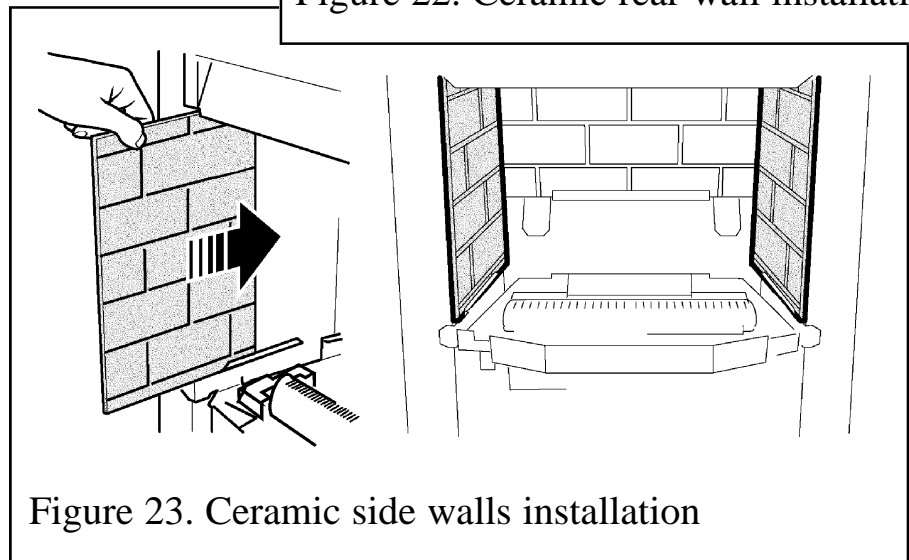

Figure 23. Ceramic side walls installation

12. FITTING THE FASCIA

12.1 Fitting the Bolero fascia.

1. As supplied the fascia has two additional brackets which are not required. These are located at the top of the side sections. Unscrew and remove the brackets.

2. Carefully lift the fascia. Place the fascia against the fireplace front surface so that the two retaining plates at the back of the fascia are directly above the two upper retaining brackets at the top of the hotbox. Lower the fascia unit making sure that the retaining plates locate fully into the brackets on the hotbox (See figure 24). If the inlet pipe runs along the front of the fireplace, the bottom of the fascia will have to be swung forward to clear the pipe while lowering the fascia.

3. Secure the fascia using the two 'E' screws and 'D' washers supplied (See figure 25).

4. Fit the burner baffle to the front flanges of the burner. To do this, place the baffle against the front flanges of the burner and lower into position. The return edges on the rear of the baffle should slot over the front flanges of the burner (See figure 26).

12.2 Fitting the Westminster fascia.

1. Carefully lift the fascia. Place the fascia against the fireplace front surface so that the two retaining plates at the back of the fascia are directly above the two upper retaining brackets at the top of the hotbox. Lower the fascia unit making sure that the retaining plates locate fully into the brackets on the hotbox (See figure 24). If the inlet pipe runs along the front of the fireplace, the bottom of the fascia will have to be swung forward to clear the pipe while lowering the fascia.

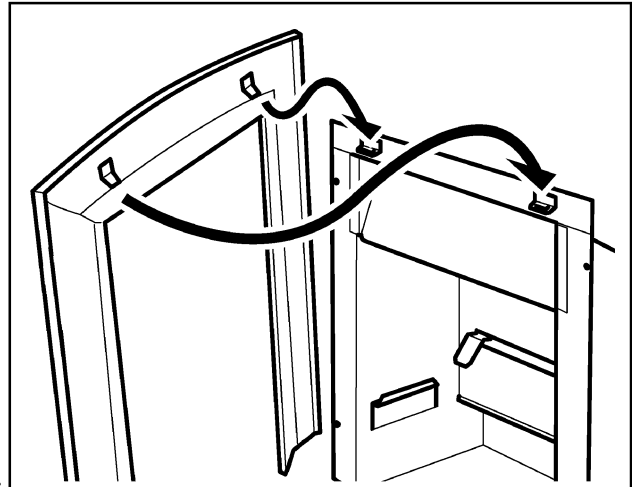

Figure 24. Fascia location (Fascia may differ from that shown)

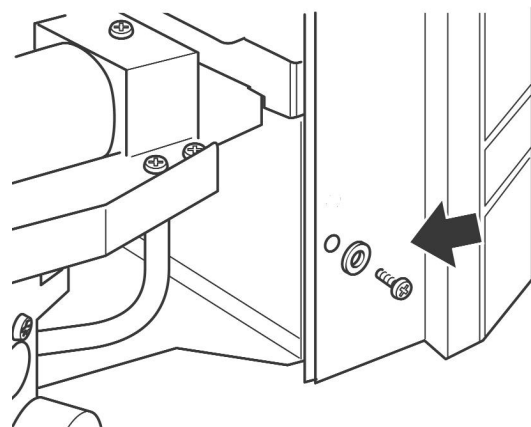

Figure 25. Fascia securing (Fascia may differ from that shown - washers only used on Bolero model)

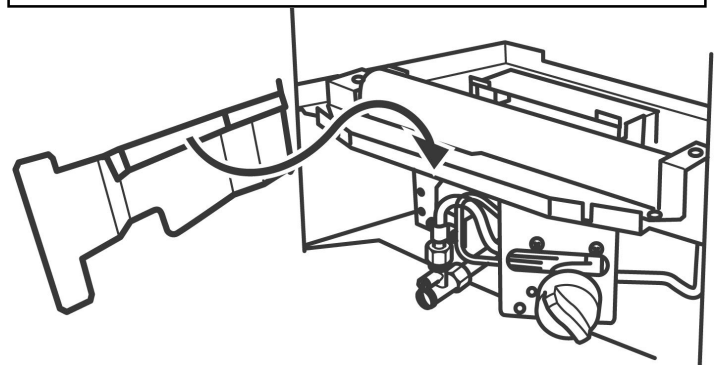

Figure 26. Fitting the burner baffle

INSTALLER GUIDE

2. Secure the fascia using the two 'C' screws supplied (See figure 25).

12.3 Fitting the Victorian fascia.

1. Carefully lift the fascia. Place the fascia against the fireplace front surface so that the four retaining plates at the back of the fascia are directly above the four retaining brackets on the hotbox. Lower the fascia unit making sure that the retaining plates locate fully into the brackets on the hotbox (See figure 27). If the inlet pipe runs along the front of the fireplace, the bottom of the fascia will have to be swung forward to clear the pipe while lowering the fascia.

2. Fit the burner baffle to the front flanges of the burner. To do this, place the baffle against the front flanges of the burner and lower into position. The return edges on the rear of the baffle should slot over the front flanges of the burner (See figure 26).

3. The Victorian fascia pack has a spillage plate cover and four magnets. Locate the four magnets approximately 20mm from the rear corners of the cover (See figure 28). Locate the cover onto the spillage plate (See figure 28). Ensure that the top locates against the upper face of the spillage plate.

12.4 Fitting the Anthem, Blenheim, Camden, Minima and Sonnet fascia.

1. The fascia is supplied in three pieces. Carefully remove the three fascia pieces from the packaging. Remove any protective film.

2. The magnets used to locate each fascia trim should already be positioned on the rear of each trim. Each fascia trim should have two magnets. If the magnets are not fitted then locate one magnet centrally at each end of the trims.

3. Locate the side fascia trims as in figure 29.

4. Locate the top fascia trim as in figure 29.

5. *Blenheim, Camden and Sonnet only* - Fit the burner baffle to the front flanges of the burner. To do this, place the baffle against the front flanges of the burner and lower into

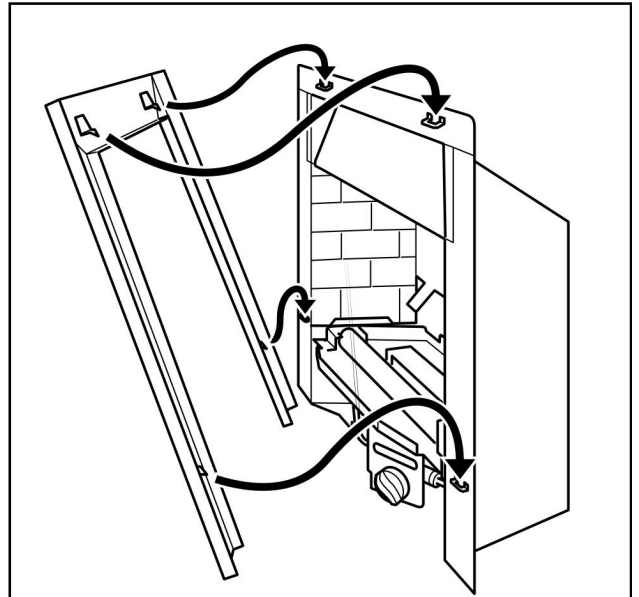

Figure 27. Fascia location (Fascia may differ from that shown)

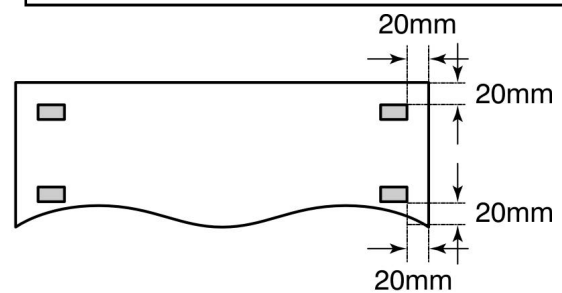
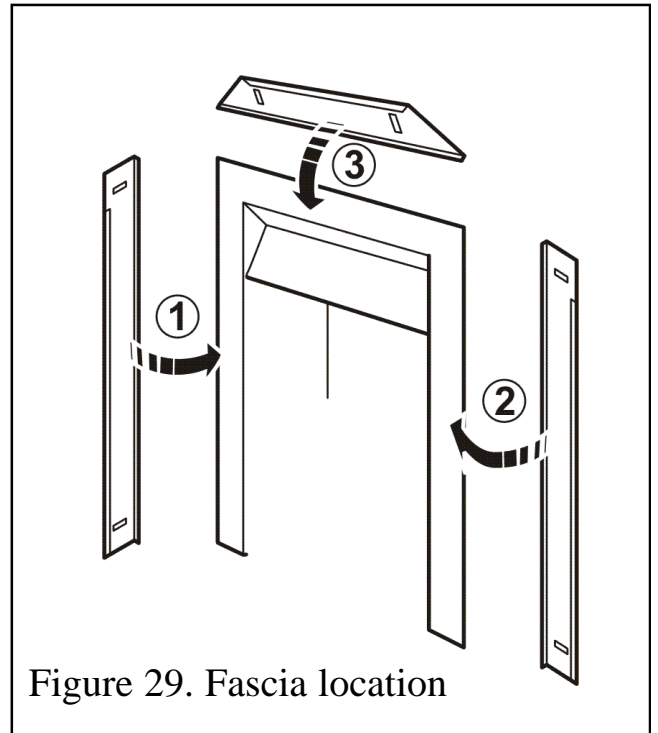

Figure 28. Spillage plate cover location

INSTALLER GUIDE

position. The return edges on the rear of the baffle should slot over the front flanges of the burner (See figure 26).



13. FITTING THE CERAMIC COAL FUEL EFFECT

This section is for models supplied with a ‘Coal’ fuel effect only.

For ‘Pebble fuel effect’ see section 14

13.1 Ceramic coal fuel effect installation for Bolero, Westminster, Victorian, Blenheim & Sonnet models.

The ceramic fuel effect may cause staining / discolouration to decorative surfaces. It is therefore advisable to protect decorative surfaces.

Note: Depending upon model the detail around the ceramic fuel effect may be different to that shown.

1. Place the ceramic base coal in the burner compartment. The bottom rear face of the coal should rest on the angled ledges at the back of the burner compartment. The bottom front recess edges on the coal base should locate against the tags at the front of the ceramic support (See figure 30).

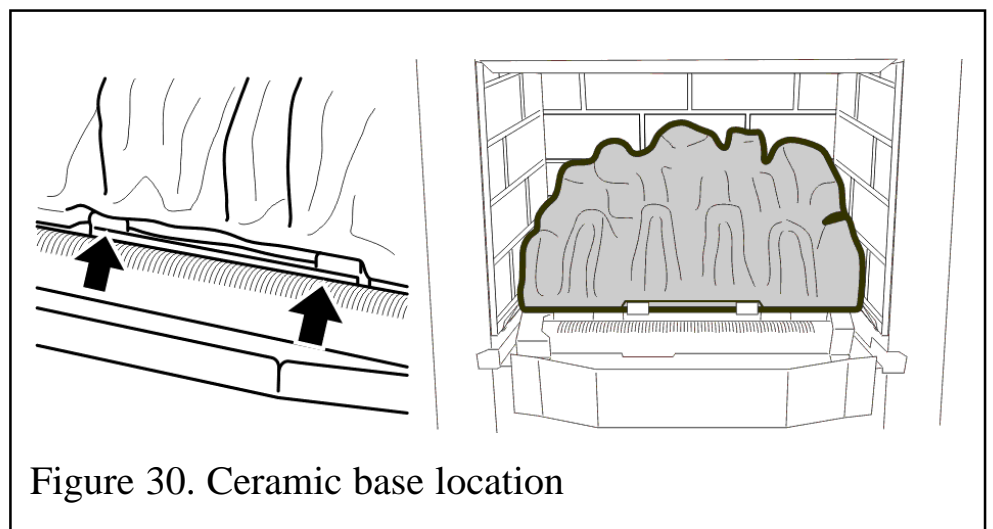

INSTALLER GUIDE

2. Place the left-hand ceramic front coal in position in front of the base coal. The front of the ceramic coal should touch the front of the burner module (See figure 31).

3. Place the right hand ceramic front coal in position in front of the base coal. This should overlap the left-hand coal. Push the two sides together to minimise the gap. The front of the ceramic coal should touch the front of the burner module (See figure 31).

4. It is important that the front ceramics are positioned correctly and do not cover the burner ports in any way (See figure 31).

Install the 12 loose coals as follows. The underside of each coal is marked with a letter 'A' to 'L' and an arrow.

The coals should be positioned so that the arrows always point towards the back of the firebox. When located into position the stem of each arrow should be at 90° to the rear of the firebox.

5. Hold coal 'A' upright with the arrow pointing to the top. Locate coal 'A' as shown in figure 32.

Locate coals 'B' to 'E' so that they are firmly seated in the valleys in the coal base and front coal.

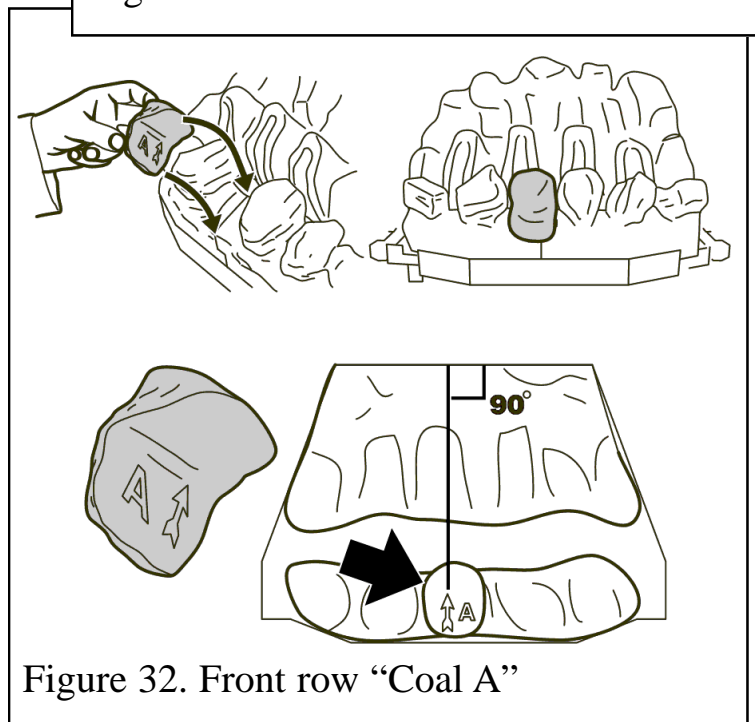

INSTALLER GUIDE

6. Hold coal 'B' upright with the arrow pointing to the top. Locate coal 'B' as shown in figure 33.

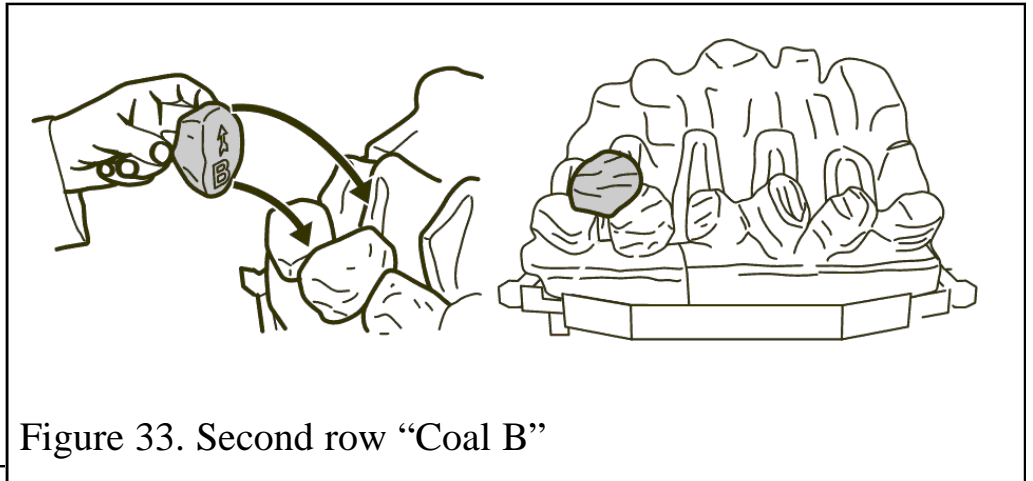

Figure 33. Second row "Coal B"

7. Hold coal 'C' upright with the arrow pointing to the top. Locate coal 'C' as shown in figure 34.

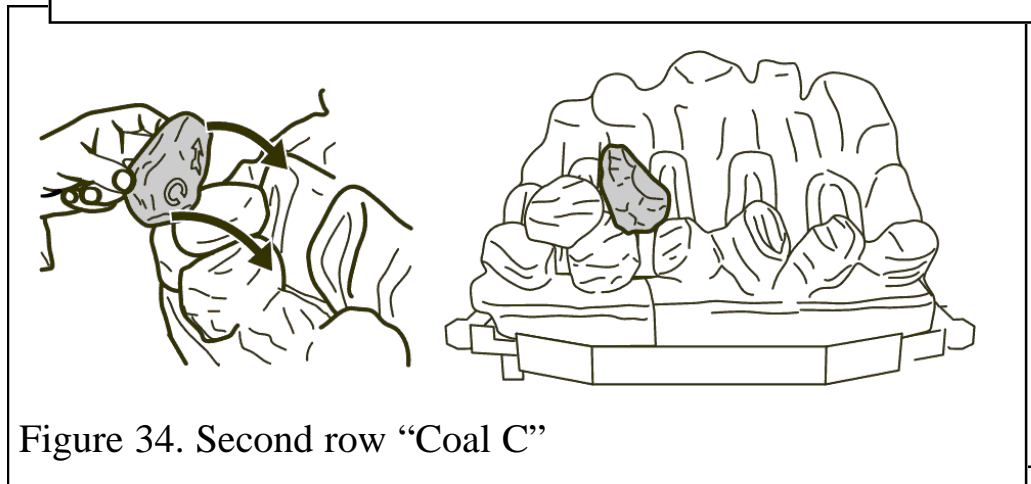

Figure 34. Second row "Coal C"

8. Hold coal 'D' upright with the arrow pointing to the top. Locate coal 'D' as shown in figure 35.

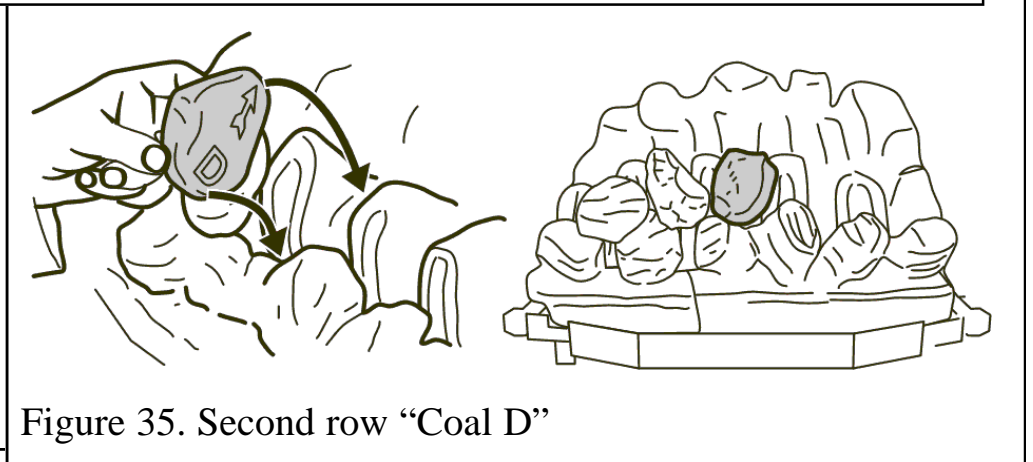

Figure 35. Second row "Coal D"

9. Hold coal 'E' upright with the arrow pointing to the top. Locate coal 'E' as shown in figure 36.

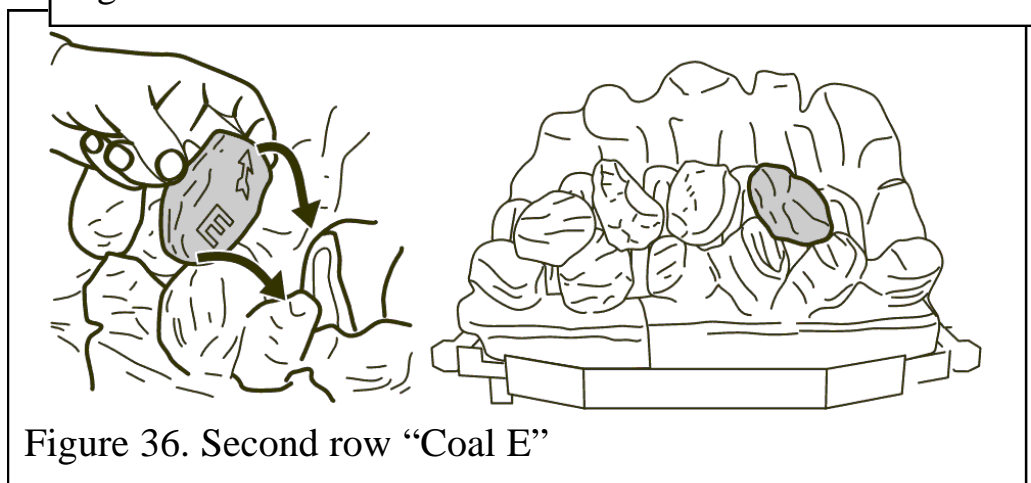

Figure 36. Second row "Coal E"

INSTALLER GUIDE

10. Hold coal 'F' upright with the arrow pointing to the top. Locate coal 'F' as shown in figure 37.

This will complete the second row of loose coals.

Locate coals 'G' to 'K' so that they are firmly seated in the valleys in the coal base.

11. Hold coal 'G' upright with the arrow pointing to the top. Locate coal 'G' as shown in figure 38.

12. Hold coal 'H' upright with the arrow pointing to the top. Locate coal 'H' as shown in figure 39.

13. Hold coal 'I' upright with the arrow pointing to the top. Locate coal 'I' as shown in figure 40.

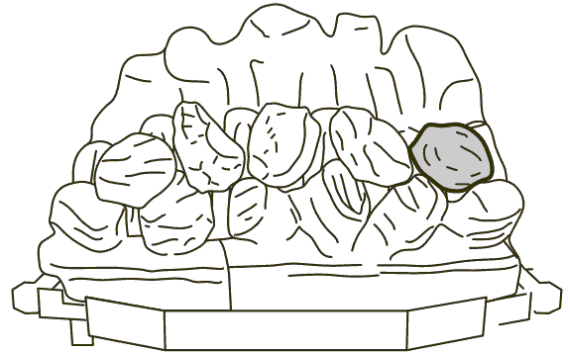
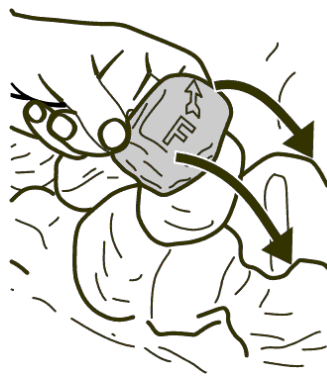

Figure 37. Second row "Coal F"

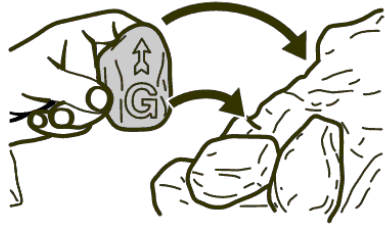

Figure 38. Third row "Coal G"

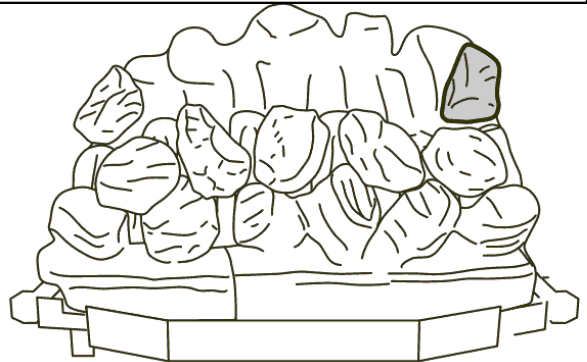
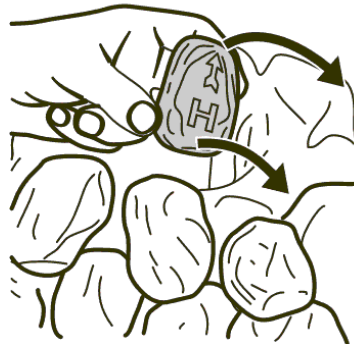

Figure 39. Third row "Coal H"

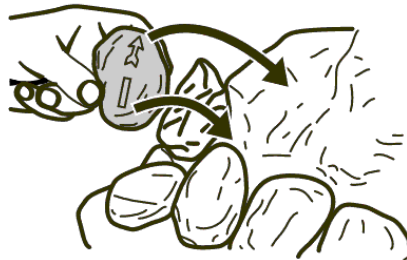

Figure 40. Third row "Coal I"

INSTALLER GUIDE

14. Hold coal 'J' upright with the arrow pointing to the top. Locate coal 'J' as shown in figure 41

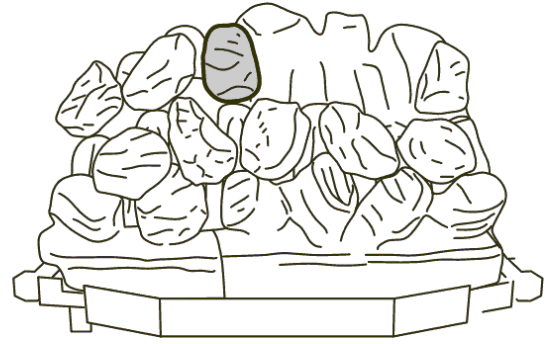

Figure 41. Third row "Coal J"

15. Hold coal 'K' upright with the arrow pointing to the top. Locate coal 'K' as shown in figure 42.

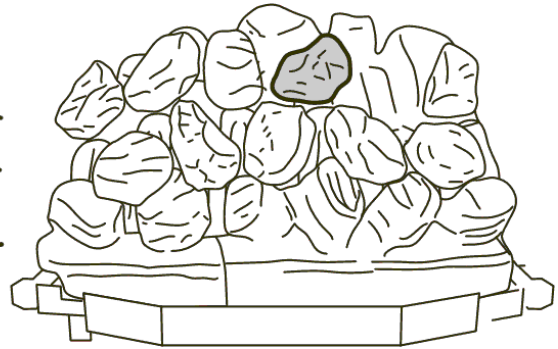
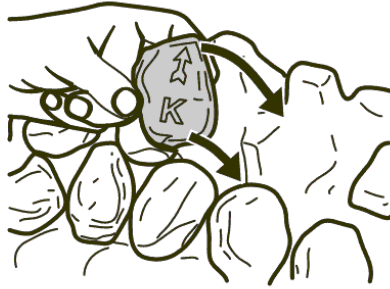

Figure 42. Third row "Coal K"

16. Hold coal 'L' upright with the arrow pointing to the top. Locate coal 'L' as shown in figure 43.

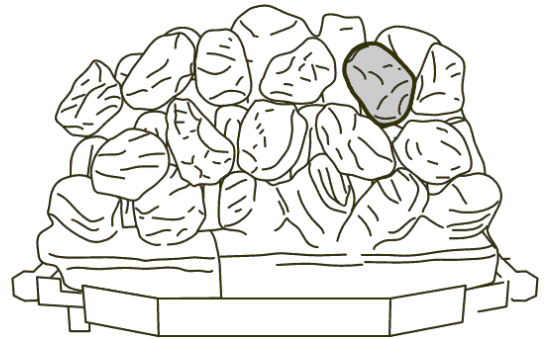

Figure 43. Third row "Coal L"

INSTALLER GUIDE

14. FITTING THE CERAMIC PEBBLE FUEL EFFECT

This section is for models supplied with a ‘Pebble’ fuel effect only.

For ‘Coal fuel effect’ see section 13.

14.1 Ceramic pebble fuel effect installation for Minima, Camden and Anthem models.

The ceramic fuel effect may cause staining / discolouration to decorative surfaces. It is therefore advisable to protect decorative surfaces.

Note: Depending upon model the detail around the ceramic fuel effect may be different to that shown.

Place the ceramic pebble base behind the main burner. The bottom rear face of the pebble base should rest on the metal supports at the rear of the hot box. The bottom front recess edge on the pebble base should locate against the tags at the front of the ceramic support (See figure 44).

2. Place the right-hand ceramic front pebbles in position in front of the base pebble. The front of the ceramic pebbles should touch the front of the burner module (See figure 45).

3. Place the left hand ceramic front pebbles in position in front of the base pebbles. This should join with the right-hand pebbles. Push the two sides together to minimise the gap. The front of the ceramic pebbles

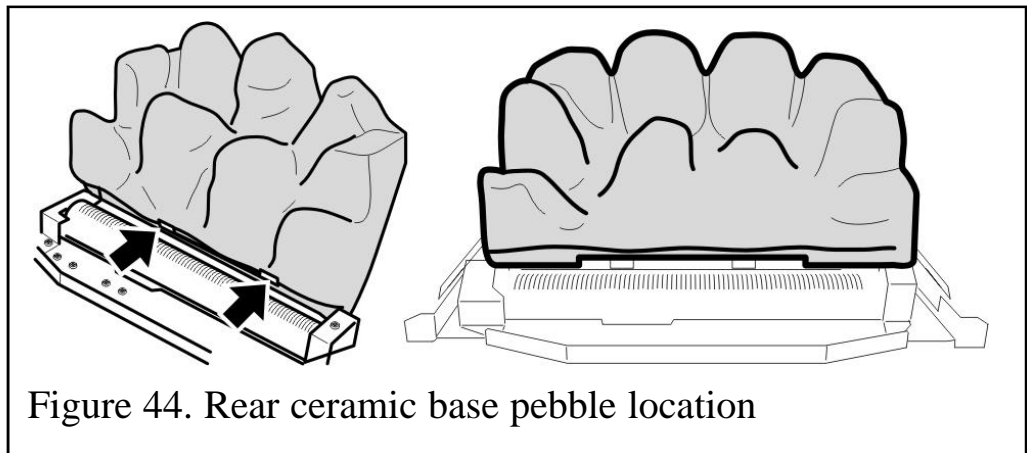

Figure 44. Rear ceramic base pebble location

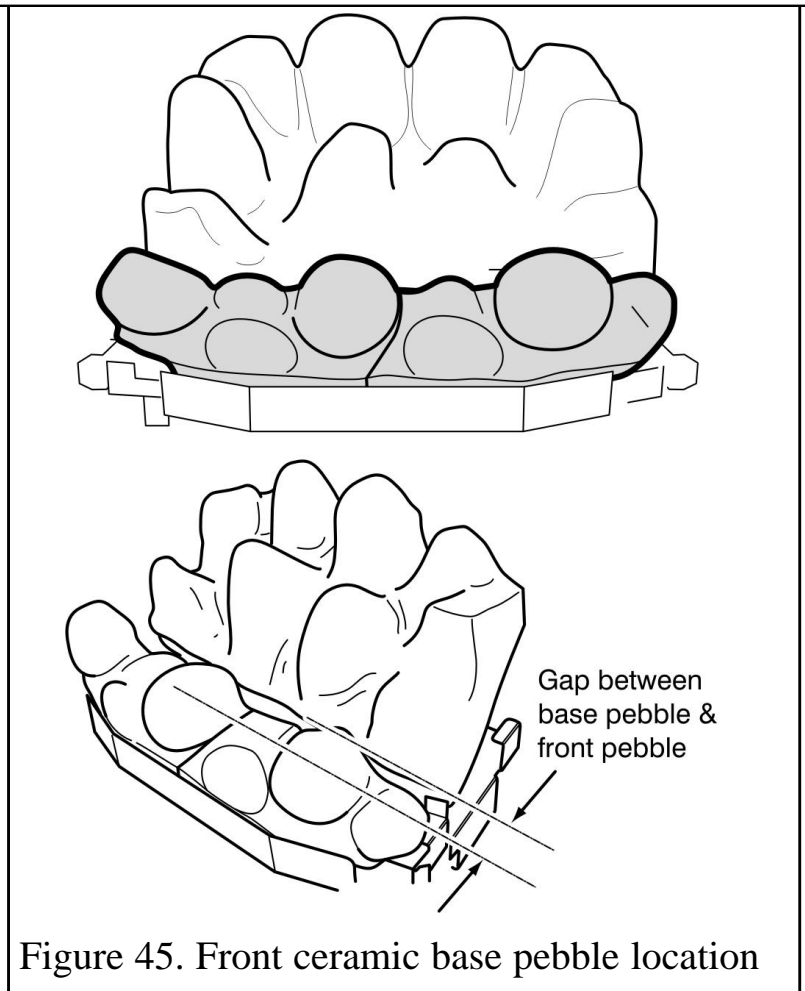

Figure 45. Front ceramic base pebble location

INSTALLER GUIDE

should touch the front of the burner module (See figure 45).

4. There will be a gap between the rear of the front pebbles and the front of the base pebbles (See figure 45).

Install the 12 loose pebbles as follows. The underside of each pebble is marked with a number '1' to '12' and an arrow.

The pebbles should be positioned so that the arrows always point towards the back of the fireplace opening. When located into position the stem of each arrow should be at 90° to the rear of the fireplace opening (See figure 46).

5. Hold pebble '1' upright with the arrow pointing to the top. Locate pebble '1' as shown in figure 46. It should lie on top of the left hand front pebbles allowing a gap to its right. This is to ensure that the pilot flame is visible to the customer.

6. Hold Pebble '2' upright with the arrow pointing to the top. Locate Pebble '2' as shown in figure 47. It should lie on top of the right hand front pebbles. This will complete the front row of pebbles.

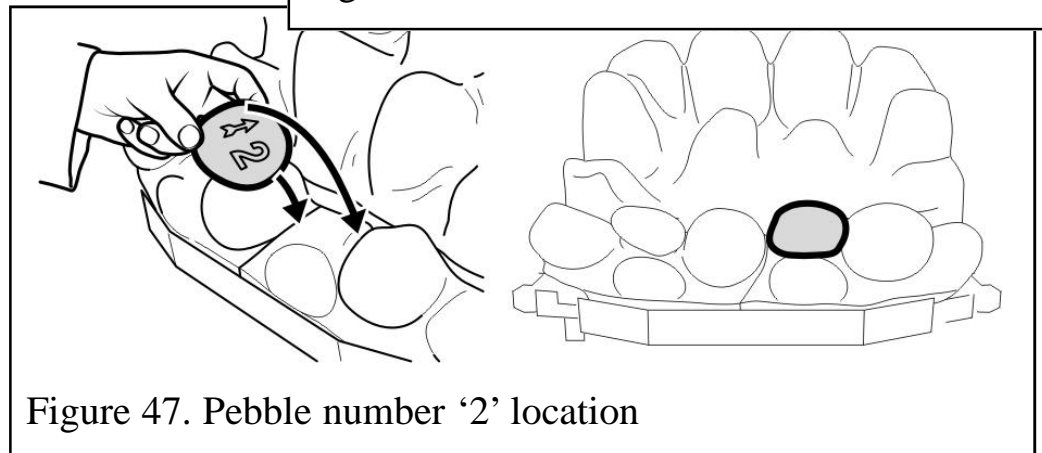
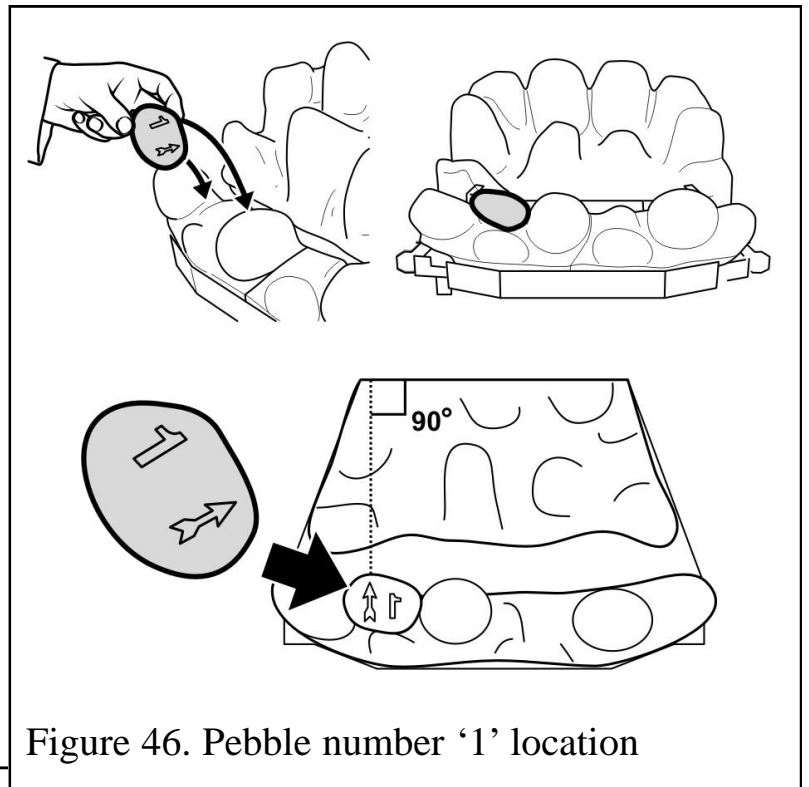

INSTALLER GUIDE

Locate pebbles '3' to '7' so that they are firmly seated in the valleys in the pebble base and front pebbles.

7. Hold pebble '3' upright with the arrow pointing to the top. Locate pebble '3' as shown in figure 48.

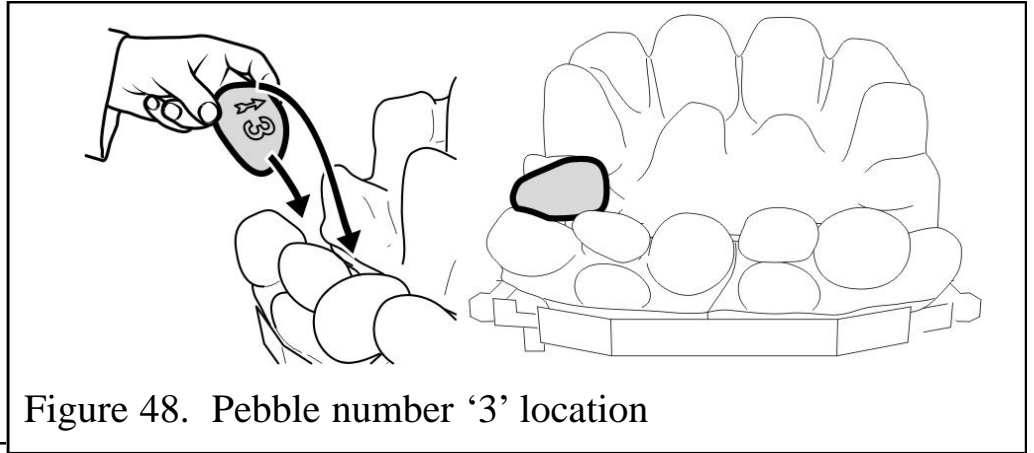

8. Hold pebble '4' upright with the arrow pointing to the top. Locate pebble '4' as shown in figure 49.

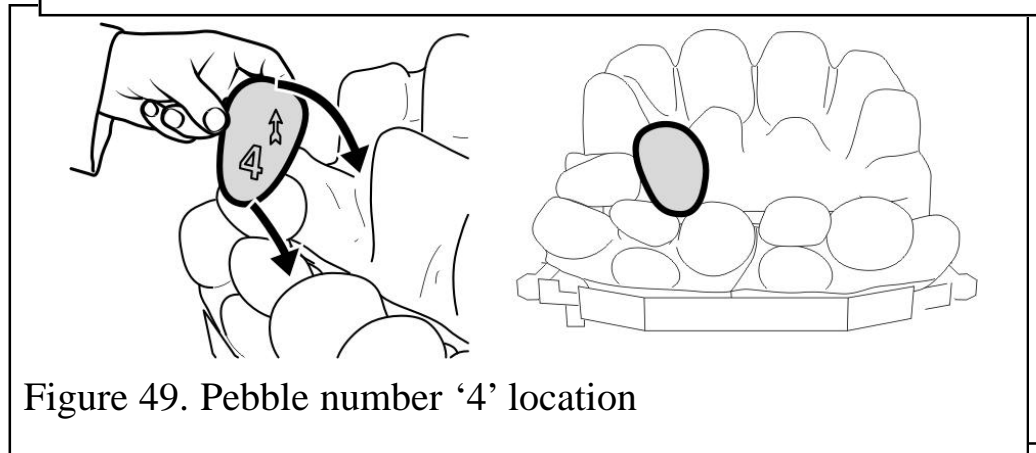

9. Hold pebble '5' upright with the arrow pointing to the top. Locate pebble '5' as shown in figure 50.

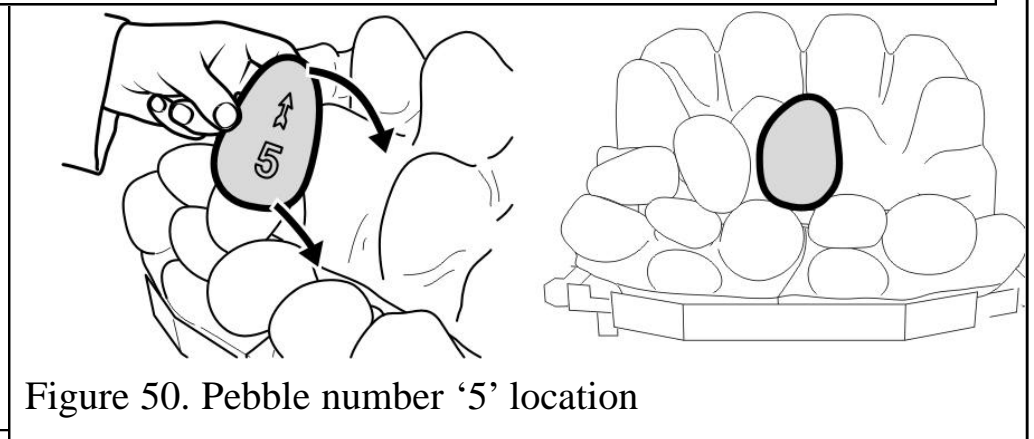

10. Hold pebble '6' upright with the arrow pointing to the top. Locate pebble '6' as shown in figure 51.

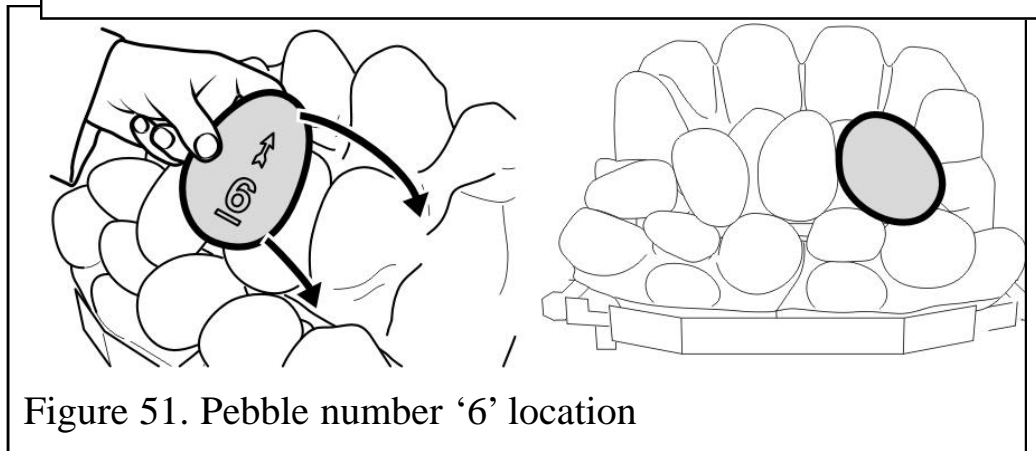

INSTALLER GUIDE

11. Hold pebble '7' upright with the arrow pointing to the top. Locate pebble '7' as shown in figure 52.

This will complete the second row of loose pebbles.

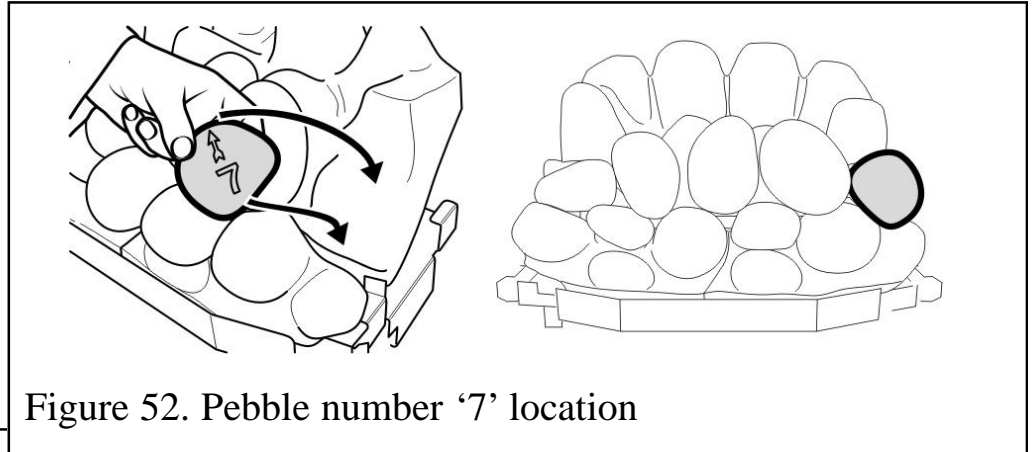

Locate pebbles '8' to '12' so that they are firmly seated in the valleys in the pebble base.

12. Hold pebble '8' upright with the arrow pointing to the top. Locate pebble '8' as shown in figure 53. The right hand end of pebble '8' should touch the upright pebble on the rear base pebble.

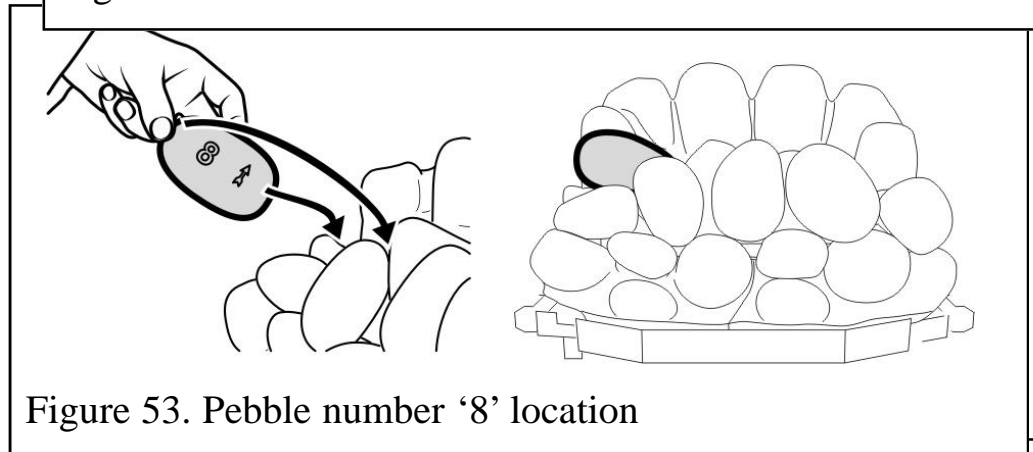

Hold pebble '9' upright with the arrow pointing to the top. Locate pebble '9' as shown in figure 54.

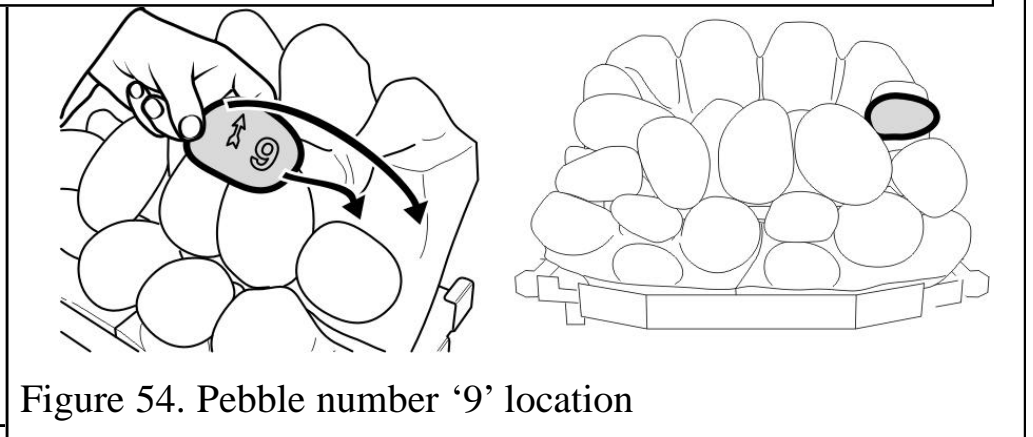

13. Hold pebble '10' upright with the arrow pointing to the top. Locate the pebble '10' as shown in figure 55.

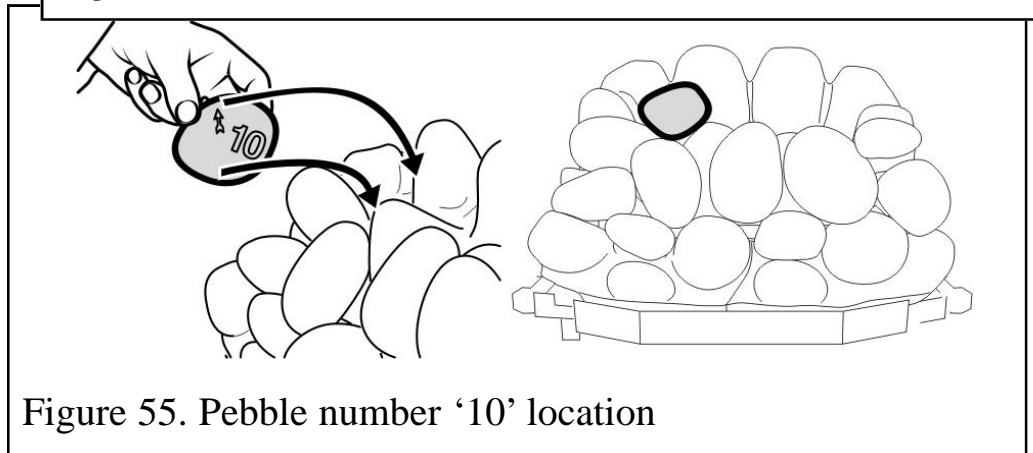

INSTALLER GUIDE

14. Hold pebble '11' upright with the pebble pointing to the top. Locate the pebble '11' as shown in figure 56.

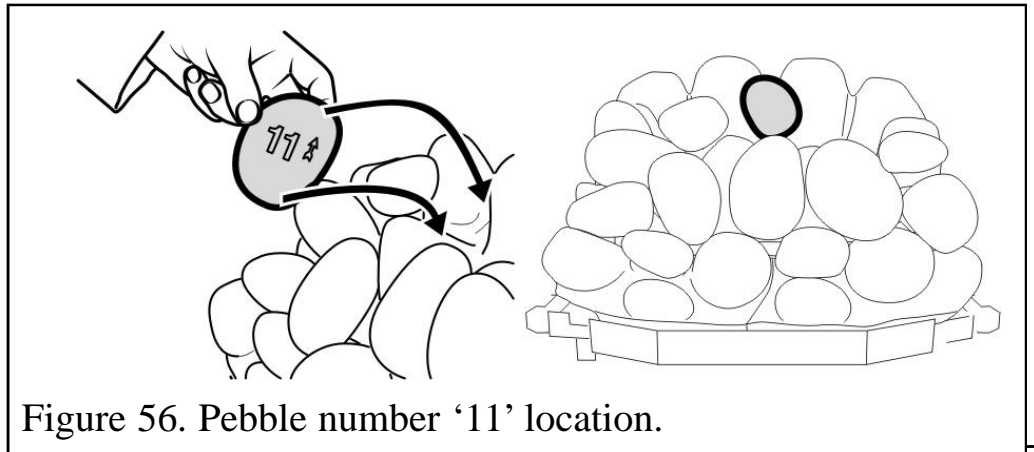

15. Hold pebble '12' upright with the pebble pointing to the top. Locate the pebble '12' as shown in figure 57.

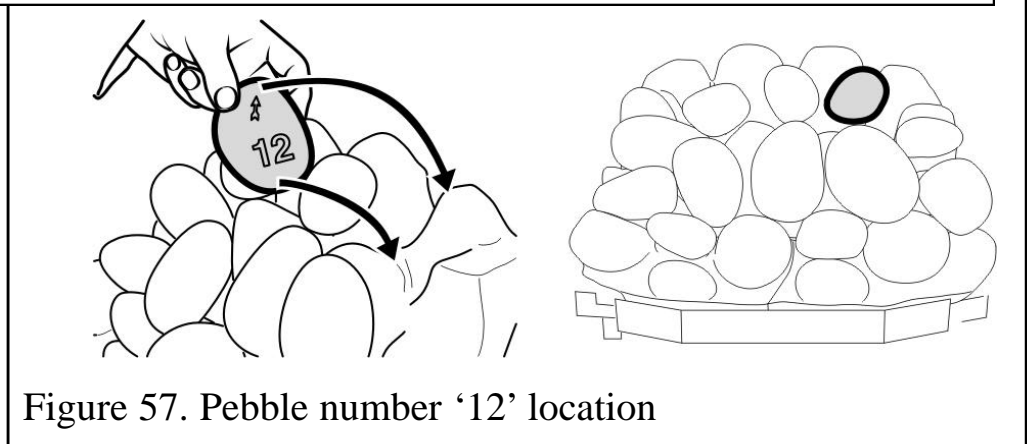

15. FITTING THE FIREFRONT

15.1 Fitting the Blenheim, Bolero and Sonnet firefront.

1. Place the firefront casting centrally on the hearth in front of the fascia.
2. Place the bottom front cover casting in position below the fire front casting.

15.2 Fitting the Westminster firefront.

1. The Westminster firefront hooks onto the fascia at four points. Locate the firefront casting onto the fascia by locating the upper hooks and lower hooks as in figure 58.
2. Locate the lower firefront to the firefront casting as in figure 58.

15.3 Fitting the Victorian firefront.

1. Fit the finials to the top of the firefront casting by screwing them into place.
2. Place the firefront casting centrally on the hearth in front of the fascia.
3. Place the bottom front cover casting in position

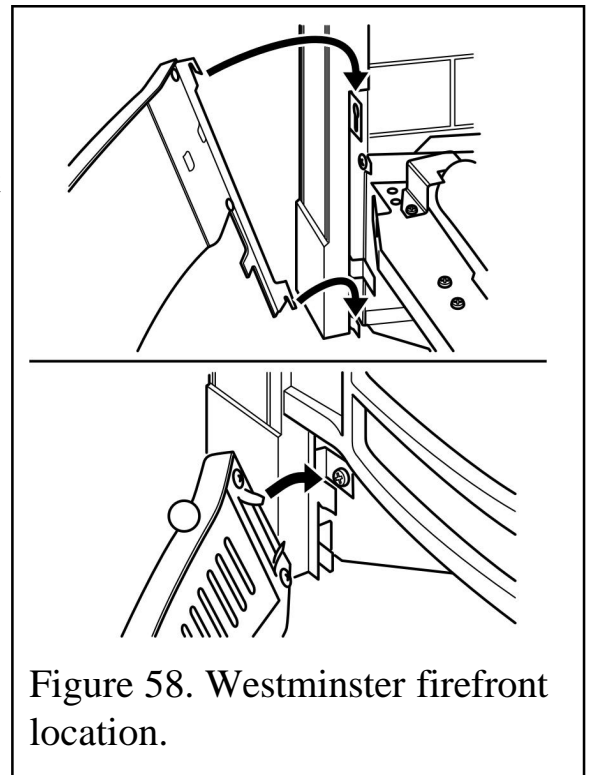

INSTALLER GUIDE

below the fire front casting.

15.4 Fitting the Anthem firefront.

1. The Anthem firefront is fitted with a set of fixing brackets. Each bracket has two threaded holes. As supplied the top threaded hole should be fitted with a 25mm long machine screw. Remove the machine screw and locate to the threaded hole below.
2. The screw should be set at a distance of 7mm (Measured from the surface of the bracket to the underside of the screw head). Adjust the screw to this distance (See figure 59).
3. Locate the firefront as in figure 60. The screw heads should locate into the slots in the burner tray.
4. The lower 'ash pan' casting should be located as in figure 61.

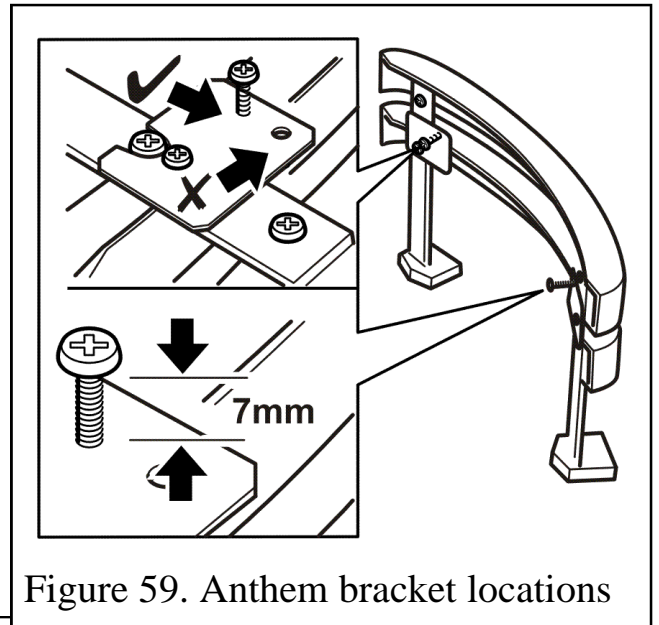

Figure 59. Anthem bracket locations

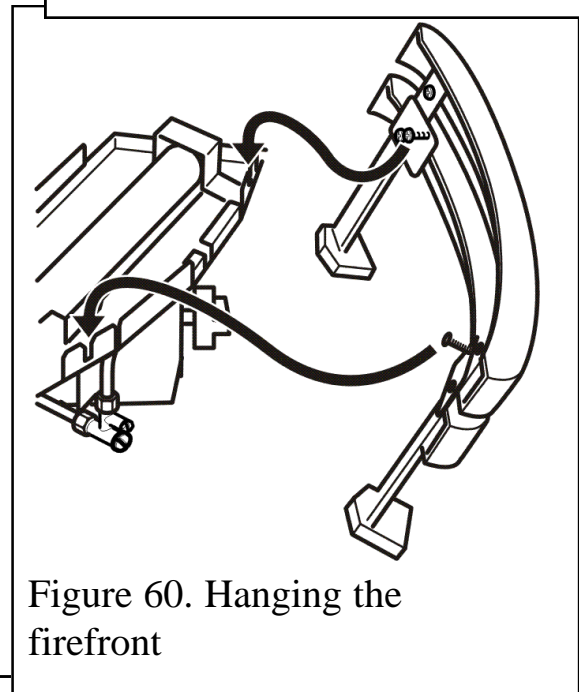

Figure 60. Hanging the firefront

15.5 Fitting the Camden and Minima firefront.

1. Place the firefront centrally on the hearth in front of the fascia.

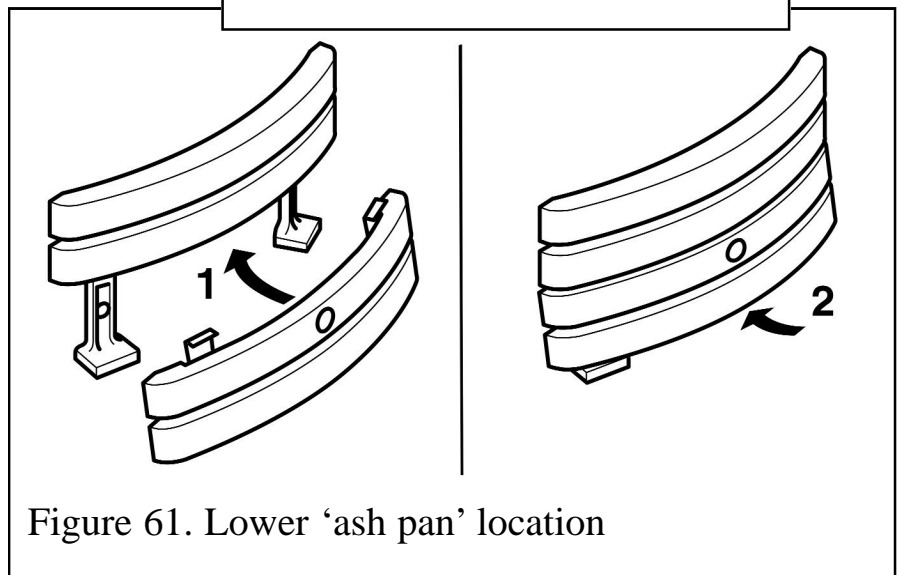

Figure 61. Lower 'ash pan' location

16. FULL OPERATING CHECKS

16.1 Check the control settings.

With the ceramic fuel effect in position the control operation must now be fully rechecked. Make sure that the isolating valve at the elbow is open.

- *When first turned on from cold, the flames will appear predominantly blue.*
- *When operating the fire for the first time, some vapours may be given off which could set off smoke alarms in the vicinity. These vapours are quite normal with new appliances. They are totally harmless and will disappear after a few hours use.*

16.1.1 Lighting the burner.

1. If closed, open the isolating valve at the inlet elbow.
2. Depress the control knob and rotate it anticlockwise to the pilot ignition position. A 'click' will be heard as the integral piezo operates. A spark should be seen between the electrode and pilot tip.
3. Turn the control knob clockwise to the 'Off' position. Repeat this operation until a flame appears at the pilot. There may be a delay before the pilot lights due to air being purged from the system. When a flame appears at the pilot keep the control knob depressed and hold the pilot ignition position for five seconds. When the control knob is released the pilot flame should remain lit.

16.1.2 Operating the burner.

1. When the pilot burner is operating properly, gradually turn the control knob anti-clockwise to 'HIGH' (Depress the knob slightly to get past the pilot ignition position). The main burner should now light. Depress the control knob slightly to release from the 'HIGH' position and turn back (clockwise) to 'LOW'. While turning, the burner flames should gradually become lower but remain alight. Depress the control knob slightly to release from the 'LOW' position and turn back (clockwise) to the Pilot ignition position. The main burner should extinguish but the pilot should remain alight. Depress the control knob slightly and turn back (clockwise) to turn OFF. This will extinguish the pilot.

If the above checks are satisfactory, continue with the installation. If not, check the control and ignition circuitry and components as described in the servicing section of this guide.

While cooling the ceramic fuel effect may make some crackling noises. This is quite normal.

INSTALLER GUIDE

16.2 Check for spillage.

A spillage check must be made before leaving the installed appliance with the customer. Make this with all the ceramic fuel effect pieces and the firefront in position

1. Close all doors and windows in the room containing the appliance.
2. Light the appliance and turn the control knob to the 'HIGH' position.
3. Leave the appliance on for five minutes.
4. The smoke match should be placed horizontally into the hotbox at the right hand side (See figure 62).

The installation is satisfactory if the smoke is drawn into the appliance.

If the smoke is not drawn into the appliance leave the appliance alight at the maximum setting for a further ten minutes and then repeat the test. If the smoke is still not drawn into the appliance inspect the sealing to the fireplace surround. If the sealing is satisfactory but the appliance is installed with the flue restrictor (See section 8 point 6) remove the restrictor, reseal the appliance and retest. If

smoke is still not drawn into the appliance **disconnect the appliance and seek expert advice.**

5. If the above test is satisfactory open all internal connecting doors, hatches, etc. in the room. Keep all doors and windows that open to the outside of the building closed. Recheck for spillage as above. If an extractor fan is installed in the same room as the appliance or a connecting room, check that spillage does not occur with the fan operating and all doors and other openings between the fan and the appliance open. If the smoke is drawn into the appliance, continue with the installation. If the test is not satisfactory **disconnect the appliance and advise the customer of the cause of failure.**

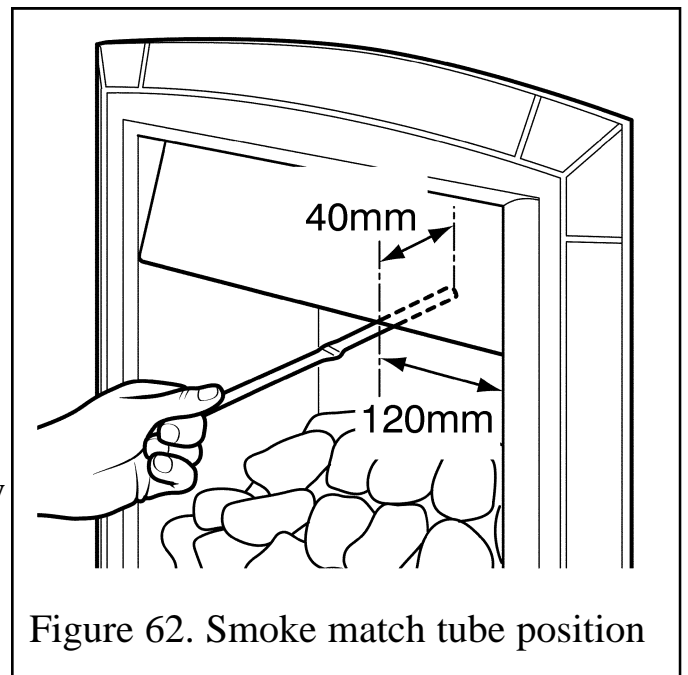

Figure 62. Smoke match tube position

16.3 Flame supervision and spillage monitoring system.

The pilot unit incorporates a system that will automatically shut off the gas supply if the pilot flame goes out or if there is insufficient oxygen due to spillage or lack of ventilation.

Check that the system operates properly as follows;

- Light the appliance. Set at the "HIGH" position and leave for one minute.
- Turn back to "OFF" to extinguish the pilot. **Note the time when the pilot goes out.**

INSTALLER GUIDE

Listen for a snap sound at the gas tap. **Note the time when the sound is heard.** This sound is caused by an electromagnetic valve shutting off the gas supply through the tap. The valve is located in the body of the tap. The valve should operate **within 60 seconds of the pilot going out.** If the valve does not operate within this time limit do not allow the appliance to be used until the fault has been corrected.

This monitoring system must not be adjusted, bypassed or put out of operation. This monitoring system, or any of its parts, must only be exchanged using Baxi Fires Division authorised parts.

17. FINAL REVIEW

1. If a gap is visible between the inner sides of the fascia and the ceramic side walls, gently slide the walls forward.
2. Visually inspect the appliance. Clean off any marks incurred during installation.
3. Advise the customer how to operate the appliance. Point out that lighting instruction details are on the metal plate attached to the burner at the bottom of the appliance. Explain to the customer that the appliance has a flame failure & spillage monitoring system. Point out the explanation of this system shown in the owner guide under “Operating the fire”. Advise that if the fire goes out for any reason, wait at least three minutes before relighting. Stress that if the monitoring system repeatedly shuts off the fire, the appliance should be switched off and a specialist should be consulted.
4. Advise the customer that they should read their owner guide before operating the fire and always follow the advice in the section headed “Cleaning your fire”.
Stress that no extra ceramic fuel effect pieces must be added over and above those supplied with the appliance and that any replacements must only be the authorised spares. Warn that ignoring this advice could cause incomplete clearance of the products of combustion with consequent health hazards.
6. Advise the customer that the appliance will operate to its maximum potential if the flue is primed during the first 20 – 30 minutes of use. To do this, simply turn the control knob to its highest setting. This will also burn off any carbon deposits that may have formed during previous use.
If using the appliance for long periods it is beneficial to change between settings. This will also help to remove any carbon deposits that may form during use.
7. Recommend that the appliance should be serviced by a competent person at least annually.
8. If the appliance is in premises in the United Kingdom occupied by a tenant, point out that by law a landlord must have any gas appliance, flue and pipework which is situated in a tenant’s premises checked for safety at least every 12 months.
9. Advise that the fire may give off a slight odour while new. This is quite normal and it will disappear after a short period of use.
10. **Inform the customer that the Serial number for the appliance is located on the**

INSTALLER GUIDE

metal plate attached to the burner at the bottom of the appliance underneath the burner module. Removal of the firefront / firefront casting will be required.

11. Hand the literature pack with this guide to the customer.

18. SERVICING & PARTS REPLACEMENT

Always turn off the gas supply before commencing any servicing (The appliance inlet elbow incorporates an isolating valve).

It is recommended that, at least once a year, the appliance is disconnected and the fireplace opening checked and cleared of any debris.

This product uses fuel effect pieces and burner compartment walls containing Refractory Ceramic Fibres (RCF), which are man-made vitreous silicate fibres. Excessive exposure to these materials may cause irritation to eyes, skin and respiratory tract. Consequently, it is important to take care when handling these articles to ensure that the release of dust is kept to a minimum. To ensure that the release of fibres from these RCF articles is kept to a minimum, during installation and servicing we recommend that you use a HEPA filtered vacuum to remove any dust and soot accumulated in and around the fire before and after working on the fire. When replacing these articles we recommend that the replaced items are not broken up, but are sealed within a heavy duty polythene bag, clearly labelled as RCF waste. This is not classified as “hazardous waste” and may be disposed of at a tipping site licensed for the disposal of industrial waste. Protective clothing is not required when handling these articles, but we recommend you follow the normal hygiene rules of not smoking, eating or drinking in the work area and always wash your hands before eating or drinking.

- Check that the appliance is clean and that soot or debris is not blocking the gaps between the ceramic fuel effect pieces causing an imperfect flame.
- Check that soot or debris is not impairing the electrode spark or pilot burner.
- Check that soot or debris is not blocking any of the slots in the main burner.
- After servicing, make sure that the ceramic walls are replaced correctly as described in this guide and the ceramic fuel effect pieces are replaced correctly as described in the installer and owner guide supplied with the ceramic fuel effect. The ceramic fuel effect guide may have been placed inside or attached to this guide.

Always test for gas soundness and spillage after servicing the appliance.

INSTALLER GUIDE

18.1 Checking the aeration setting of the burner.

1. The aeration shutter is factory set. It is important to ensure that the aeration setting is correct for the ceramic fuel effect used (See figure 63).

2. To adjust the aeration setting to suit the fuel effect used, loosen the two aeration shutter screws, slide the aeration shutter to the desired position and tighten the fixing screws.

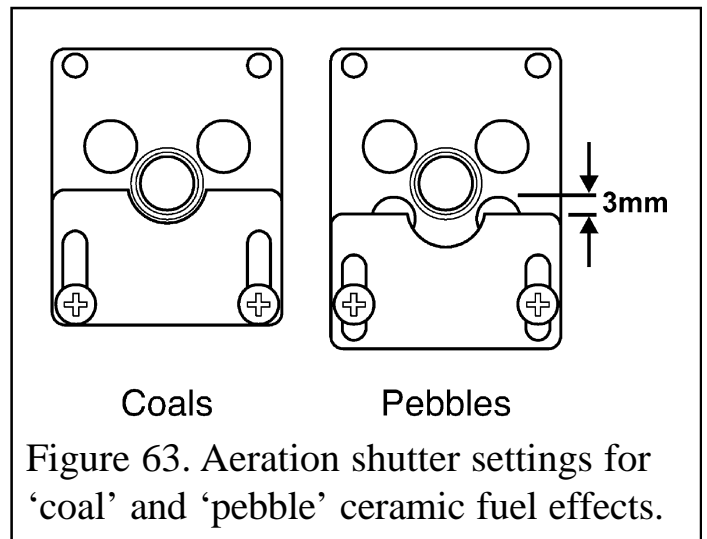

18.2 To remove the Westminster and Bolero fascia.

1. Remove the bottom front cover and the fire front casting.
2. Remove the two screws securing the bottom of the fascia to the sides of the hotbox (See figure 64). On the Bolero there is also two washers.
3. Carefully lift the fascia upward to clear the upper retaining brackets on the hotbox - (See figure 64). Pull the fascia clear and place carefully aside.
4. Refit in the reverse order. Make sure that the fascia is properly located over the upper retaining brackets. See section 12 of this manual for detailed fitting instructions.

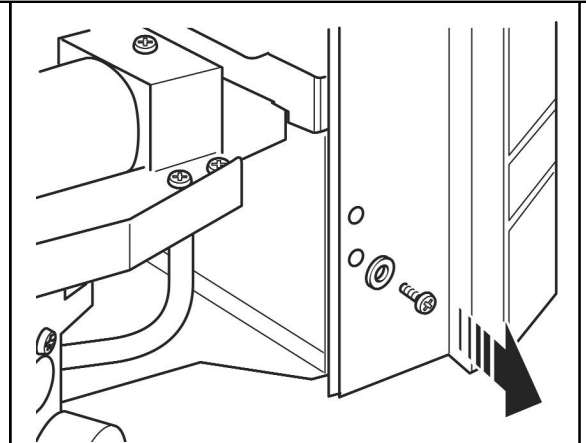

Figure 64. Removing the fascia fixing screws (Shown with Bolero fascia)

18.3 To remove the Victorian fascia.

1. Remove the bottom front cover and the fire front casting.
2. Hold the sides of the fascia and lift clear of the support brackets
4. Refit in the reverse order. Make sure that the fascia is properly located over the upper and lower retaining brackets. See section 12 of this manual for detailed fitting instructions.

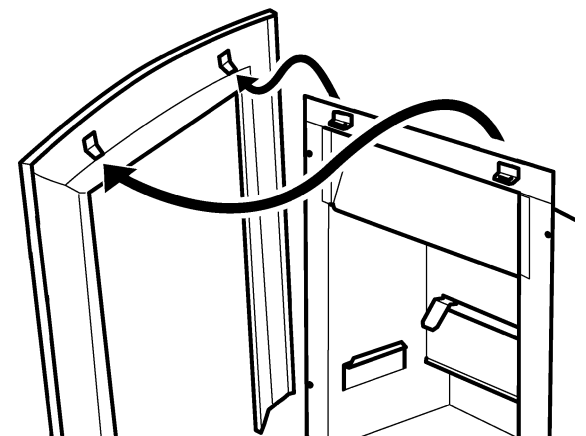

Figure 65. Front casting removal

INSTALLER GUIDE

18.4 To remove the Anthem, Blenheim, Camden, Minima and Sonnet fascia.

1. The fascia is held in place with magnets. Remove the top section first.
2. Replace in the reverse order (See section 12.4).

18.5 To remove the complete burner unit.

1. Remove the lower firefront / firefront casting and the fascia (See section 18.2 - 18.4).
2. Remove the ceramic fuel effect.
3. Support the inlet elbow to avoid straining the pipework and disconnect the appliance from the elbow.
4. Detach the burner unit from the hotbox by removing two screws (See figure 66).
5. Replace in the reverse order. The ceramic fuel effect pieces must be replaced as in section 13 (Coal) or section 14 (Pebble) of this guide.

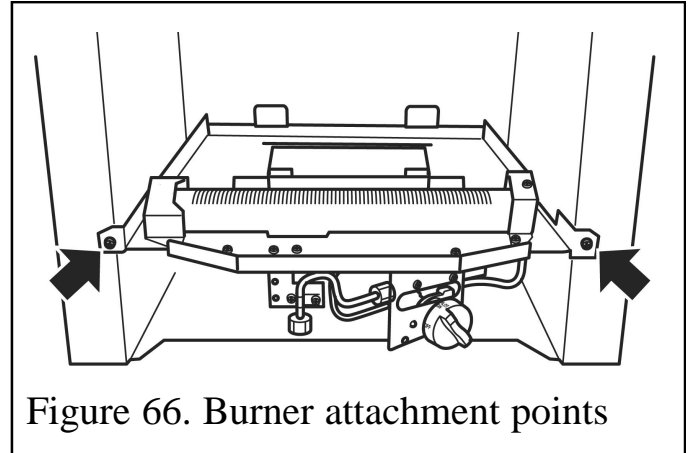

Figure 66. Burner attachment points

18.6 To remove the pilot unit.

1. Remove the burner unit (See section 18.5).
2. Detach the pilot pipe from the pilot unit.
3. Detach the thermocouple from the gas valve.
4. Detach the electrode lead from the underside of the electrode tab.
5. Remove the two screws securing the pilot unit (See figure 67).
6. Refit in the reverse order.

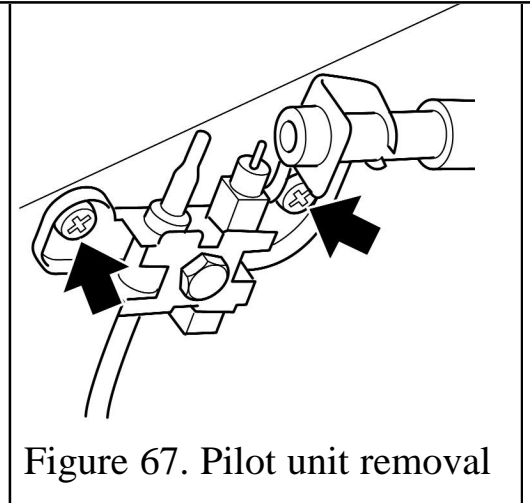

Figure 67. Pilot unit removal

Note:

1. *The pilot unit is an atmosphere sensing device. It must be replaced as a whole assembly. Its individual components are not separately replaceable.*

INSTALLER GUIDE

18.7 To remove the gas valve.

(See figure 68).

1. Remove the burner unit (See section 18.5).
2. If lying the burner on its back, ensure that the work surface is suitably protected. This will avoid damage to the work surface. Turn the burner unit upside down. Detach the thermocouple from the tap.
3. Detach the pilot pipe from the tap.
4. Detach the inlet pipe.
5. Detach the injector pipe.
6. Detach the electrode lead from the base of the electrode.
7. Remove the control knob by pulling forward.
8. Remove the thermocouple by unscrewing the thermocouple nut at the gas valve.
9. Remove the hexagonal nut securing the gas valve to the mounting bracket.
10. Remove the gas valve.
11. Refit in the reverse order.

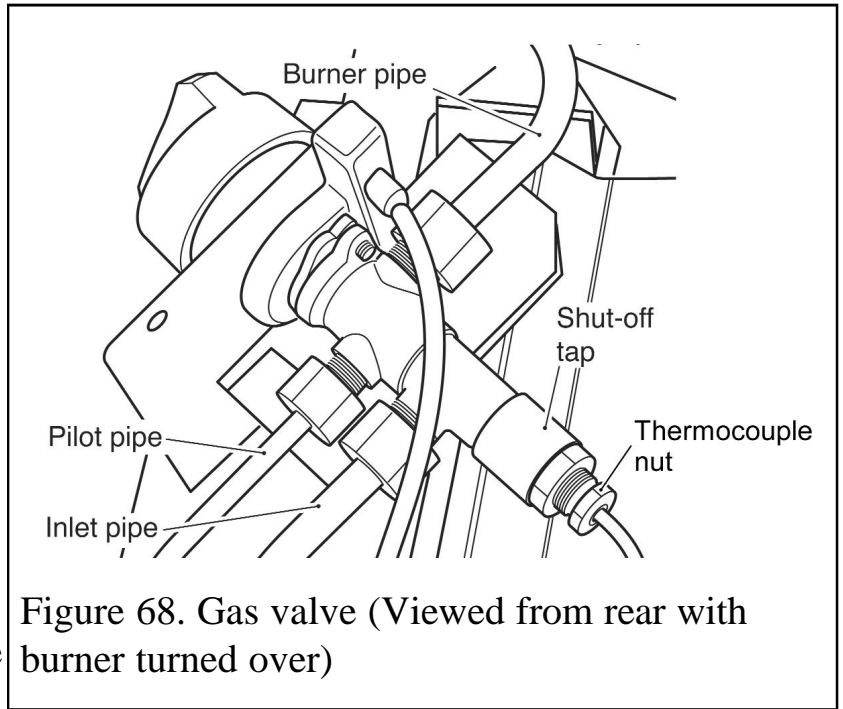

18.8 To remove the piezo generator.

1. Remove the gas tap as section 18.7.
2. Make sure that the tap is in the off position.
3. Remove the circlip holding the piezo unit to the tap. Remove the piezo unit.
4. Replace in the reverse order.

18.9 To grease the control tap.

1. Detach the tap and remove the piezo generator as section 18.8 making sure that the tap is in the off position.
2. Remove the two screws from the head of the tap. Remove the niting head and spindle complete with collar and spring.
3. Note the position of the slot in the plug-mark its position on the tap body.
4. Remove the plug rotating slightly while pulling.
5. Clean and grease the plug lightly with suitable grease. Do not apply excessive grease. Particularly, make sure that the gas ports in the tap are not restricted by grease.
6. Push the plug into the tap body and position the slot in line with the mark previously made on the tap body.
7. Reassemble the niting head and spindle complete with collar and spring making sure that the components are correctly engaged. Check the operation of the tap.
8. Refit the piezo generator.

INSTALLER GUIDE

18.10 To replace the burner.

(See figure 69).

1. Remove the burner unit (See section 18.5).
2. Support the elbow injector and unscrew the injector nut.
3. Remove the two screws from the burner clamping plate (See figure 69)
4. Lift the right hand side of the burner, slide it to the right and lift clear
5. Refit in reverse order.

18.11 To remove the main burner injector.

(See figure 70).

1. Remove the burner (See section 18.8).
2. Remove the burner clamping screw (See figure 70)
3. Unscrew the injector from the burner
4. Refit in the reverse order.

18.12 To remove the appliance from the fireplace.

1. Remove the burner unit - See section 18.5.
2. If the fire retention is as method 1 (See section 9.1 of installation instructions), remove the screws.
If the fire retention is as method 2 (See section 9.2 of this guide), slacken the hexagonal adjusters on the cable adjusters and unscrew the thumb screw to release the cables.
3. Refit as described in the relevant installation sections. Make sure gas soundness, sealing, spillage test and performance are satisfactory.

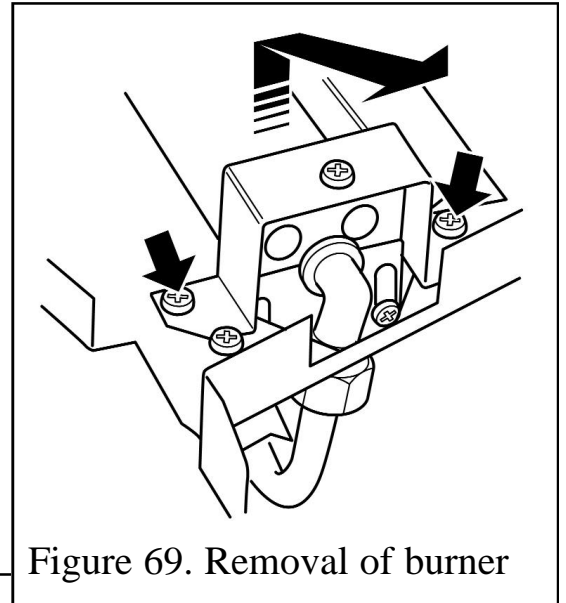

Figure 69. Removal of burner

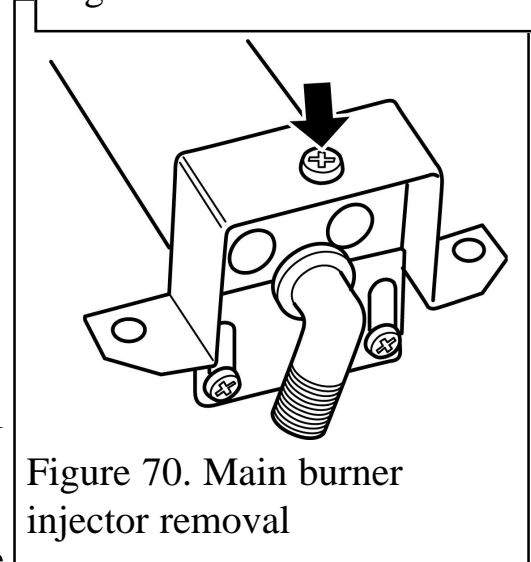

Figure 70. Main burner injector removal