

CONTENTS

1	DESCRIPTION OF MODULAR UNIT	pag.	42
2	ASSEMBLING THE BOILER SUPPORT FRAME	pag.	53
3	CONNECTING UP CONNECTIONS AND CONDENSATION DRAIN	pag.	54
4	EXHAUST GAS FLUE AND SEQUENCE/CASCADE UNIT	pag.	58
5	ELECTRICAL CONNECTION OF BOILERS AND SAFETY KITS	pag.	59

1 DESCRIPTION OF MODULAR UNIT

1.1 INTRODUCTION

The kits described in this manual are constructed for designing and planning a modular unit composed of multiple premixed condensation boilers in the "PLANET DEWY 60 BFR" (Supplied as Class B device) series linked in sequence/cascade independently of one another.

The boilers are started up by a sequencing unit which controls automatic inclusion or exclusion of individual heating units contained in a single structure.

Total thermal power depends on the number of boilers installed (two boilers give a total

thermal power of 113.9 kW, three boilers 170.9 kW, four boilers 227.8 kW, five boilers 284.8 kW and six boilers 341.7 kW).

The kits used for hydraulic connection and release of exhaust gases are:

- code 8102460 for "DEWY EQUIPE 120"
- code 8102465 for "DEWY EQUIPE 180"
- code 8102470 for "DEWY EQUIPE 240"
- code 8102475 for "DEWY EQUIPE 300"
- code 8102480 for "DEWY EQUIPE 360"

A safety kit is available separately, to be requested as appropriate to the positioning of the connections:

- code 8101501 for connections on the right side
- code 8101500 for connections on the left side.

In addition, for "DEWY EQUIPE 300-360" models, you will need to request an additional safety valve kit, code 8103825.

As it is a thermal unit, the boiler room must comply with the dimensions and requirements of current legislation.

Ventilation openings must be made in the external walls of the room to permit air to flow into the room. Their size must be calculated on the basis of the applicable legislation, and must never be smaller than 3,000 cm² or, in the case of gas with a density of more than 0.8, 5,000 cm².

1.2 DIMENSIONS AND CONNECTIONS OF "DEWY EQUIPE 120-240"

1.2.1 "DEWY EQUIPE 120-180-240"

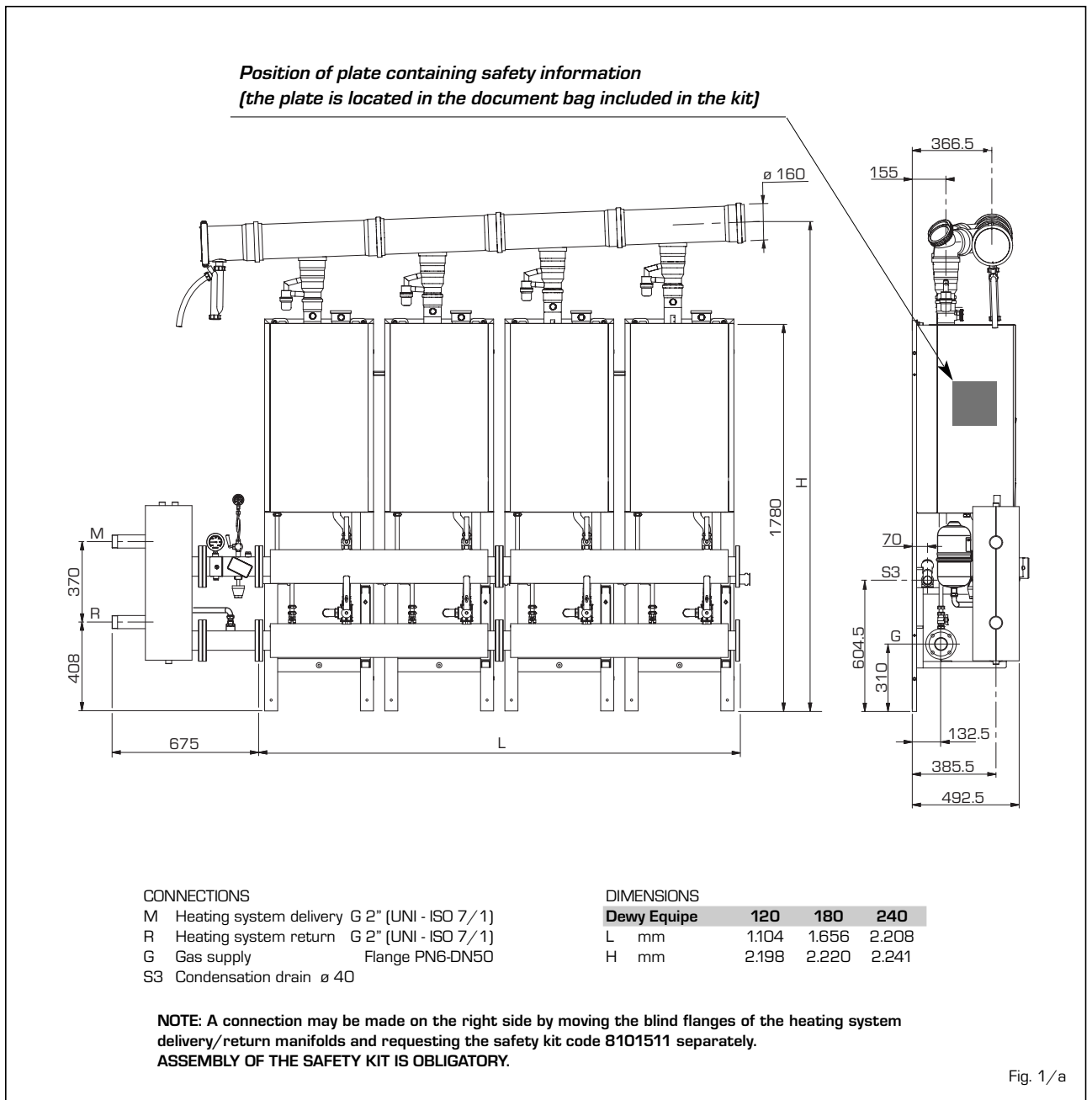

1.2.2 "DEWY EQUIPE 300-360"

*Position of plate containing safety information
(the plate is located in the document bag included in the kit)*

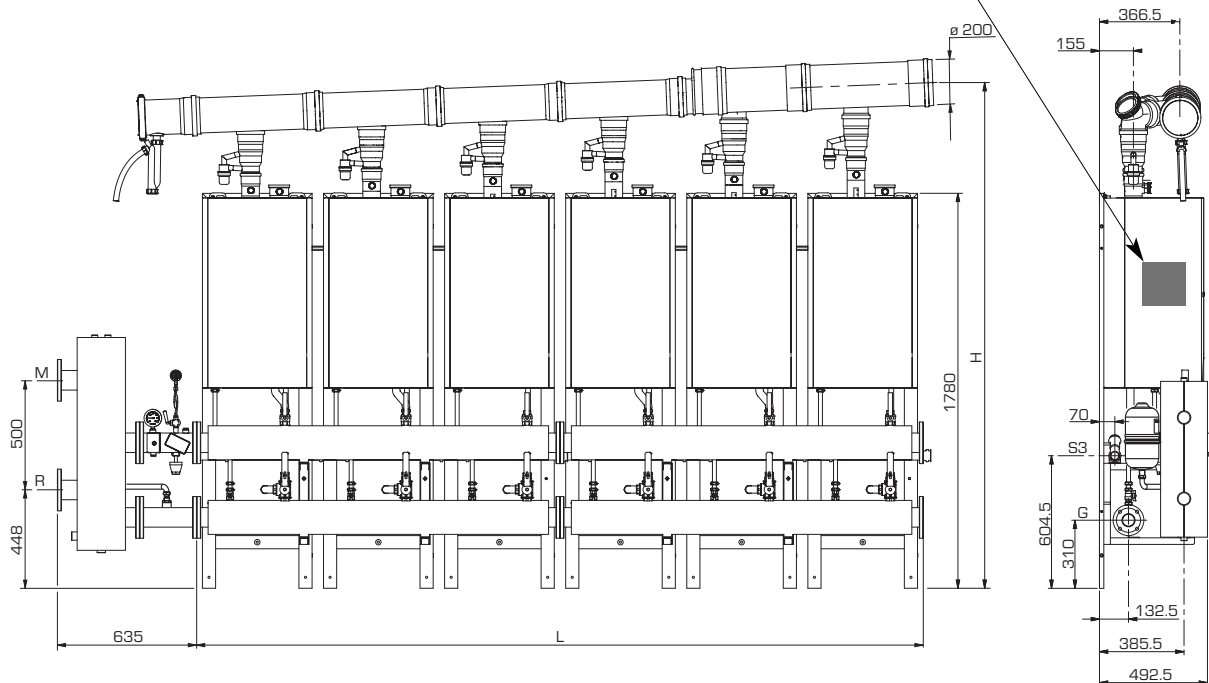

CONNECTIONS

M	Heating system delivery	Flange PNG-DN80
R	Heating system return	Flange PNG-DN80
G	Gas supply	Flange PNG-DN50
S3	Condensation drain	∅ 40

DIMENSIONS

Dewy Equipe	300	360
L	mm	2.760 3.312
H	mm	2.284 2.305

NOTE: A connection may be made on the right side by moving the blind flanges of the heating system delivery/return manifolds and requesting the safety kit code 8101511 and the additional safety kit code 8103825 separately. ASSEMBLY OF THE SAFETY KIT IS OBLIGATORY.

Fig. 1/b

IT

ES

GB

FR

BE

1.3 TECHNICAL DATA

DEWY EQUIPE		120	180	240	300	360
Nominal thermal power (80-60°C)	kW	113,9	170,9	227,8	284,8	341,7
	kcal/h	98.000	146.900	196.000	244.900	293.900
Nominal thermal power (50-30°C)	kW	124,5	186,7	248,9	311,2	373,4
	kcal/h	107.000	160.600	214.000	267.600	321.100
Min. thermal power G20 (80-60°C)	kW	16,8	16,8	16,8	16,8	16,8
	kcal/h	14.400	14.400	14.400	14.400	14.400
Min. thermal power G20 (50-30°C)	kW	18,2	18,2	18,2	18,2	18,2
	kcal/h	15.700	15.700	15.700	15.700	15.700
Min. thermal power G31 (80-60°C)	kW	22,4	22,4	22,4	22,4	22,4
	kcal/h	19.200	19.200	19.200	19.200	19.200
Min. thermal power G31 (50-30°C)	kW	24,3	24,3	24,3	24,3	24,3
	kcal/h	20.900	20.900	20.900	20.900	20.900
Nominal thermal capacity	kW	116,0	174,0	232,0	290,0	348,0
	kcal/h	99.800	149.600	199.500	249.400	299.300
Minimum thermal capacity G20	kW	17,4	17,4	17,4	17,4	17,4
	kcal/h	15.000	15.000	15.000	15.000	15.000
Minimum thermal capacity G31	kW	23,2	23,2	23,2	23,2	23,2
	kcal/h	19.900	19.900	19.900	19.900	19.900
Min-max useable yield (80-60°C)	%	96,4-98,2	96,4-98,2	96,4-98,2	96,4-98,2	96,4-98,2
Min-max useable yield (50-30°C)	%	104,7-107,3	104,7-107,3	104,7-107,3	104,7-107,3	104,7-107,3
Useful yield at 30% (50-30°C)	%	106,4	106,4	106,4	106,4	106,4
Energy performance marking (EEC 92/42)		★★★★	★★★★	★★★★	★★★★	★★★★
Heating units	n°	2	3	4	5	6
NOx class		5	5	5	5	5
Flue gas temperature at Nominal Q. (80-60°C)	°C	68	68	68	68	68
Flue gas temperature at Minimum Q. (80-60°C)	°C	58	58	58	58	58
Flue gas temperature at Nominal Q. (50-30°C)	°C	49	49	49	49	49
Flue gas temperature at Minimum Q. (50-30°C)	°C	42	42	42	42	42
Maximum rate of flow of flue gases	kg/h	190,5	285,7	380,9	476,2	571,4
CO ₂ at Nominal/Minimum Q. G20	%	9,0/9,0	9,0/9,0	9,0/9,0	9,0/9,0	9,0/9,0
CO ₂ at Nominal/Minimum Q. G31	%	10,0/10,0	10,0/10,0	10,0/10,0	10,0/10,0	10,0/10,0
Max. pressure at flue gas release manifold	Pa	100	100	100	100	100
Electrical power absorbed	W	396	594	792	990	1188
Degree of electric protection		IPX4D	IPX4D	IPX4D	IPX4D	IPX4D
EC certification	n°	1312BP4142	1312BP4142	1312BP4142	1312BP4142	1312BP4142
Category		II2H3P	II2H3P	II2H3P	II2H3P	II2H3P
Category in France/Belgium		II2Er/II2ES)B	II2Er/II2ES)B	II2Er/II2ES)B	II2Er/II2ES)B	II2Er/II2ES)B
Type		B23-53	B23-53	B23-53	B23-53	B23-53
HEATING						
Max. operating pressure	bar	4	4	4	4	4
Max. operating temperature	°C	85	85	85	85	85
Water content of modules	l	30,5	42,0	51,5	76,4	86,0
Temperature control individual module	°C	20/80	20/80	20/80	20/80	20/80
GAS AND NOZZLE PRESSURE						
Feed pressure G20/G25	mbar	20/25	20/25	20/25	20/25	20/25
Feed pressure G31	mbar	37	37	37	37	37
Number of nozzles	n°	2	3	4	5	6
Nozzle diameter G20/G25	ø	9,3	9,3	9,3	9,3	9,3
Nozzle diameter G31	ø	6,7	6,7	6,7	6,7	6,7
Consumption at nominal/min. power G20	m ³ /h	12,27/1,84	18,41/1,84	24,54/1,84	30,68/1,84	36,81/1,84
Consumption at nominal/min. power G31	kg/h	9,01/1,80	13,52/1,80	18,02/1,80	22,53/1,80	27,03/1,80
WEIGHT	kg	122	183	244	305	366

COMPOSITION: The "DEWY EQUIPE" modular unit is composed of 2 - 3 - 4 - 5 or 6 "PLANET DEWY 60 BFR" boilers, the technical features and dimensions of which are given in the instruction manual supplied with each boiler.

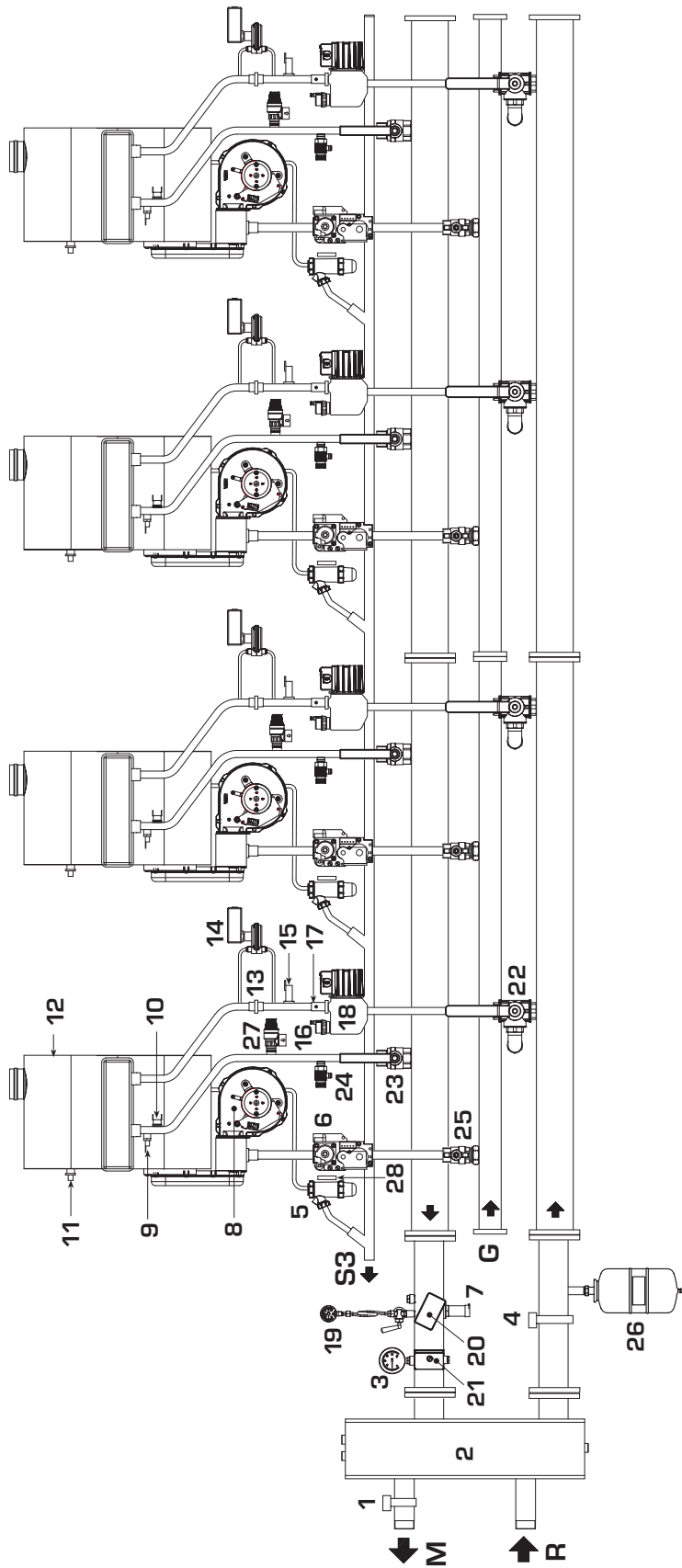

- LEGEND
- 1 Cascade delivery probe
 - 2 Hydraulic compensator
 - 3 Thermometer
 - 4 Cascade return probe
 - 5 Condensation drain trap
 - 6 Gas valve
 - 7 3.5 BAR safety valve
 - 8 Fan
 - 9 Heating probe (SM)
 - 10 95°C safety thermostat
 - 11 Flue gas thermostat
 - 12 Primary exchanger
 - 13 Diaphragm
 - 14 Differential pressure switch
 - 15 Water pressure transducer
 - 16 Air bleed valve
 - 17 Check valve
 - 18 Circulator
 - 19 0-6 BAR manometer with cock
 - 20 4 BAR water pressure switch
 - 21 100°C safety thermostat
 - 22 Three-way drain cock
 - 23 Heating system delivery cock
 - 24 Single boiler drain
 - 25 Gas cock
 - 26 8 litre expansion tank
 - 27 4 BAR safety valve
 - 28 Drain trap anti-freeze probe (BOX versions only)
- CONNECTIONS
- M Heating system delivery
 - R Heating system return
 - G Gas
 - S3 Condensation drain

Fig. 2

IT

ES

GB

FR

BE

1.5 LOAD LOSS IN HYDRAULIC SEPARATOR

DEWY EQUIPE 120 - 180 - 240

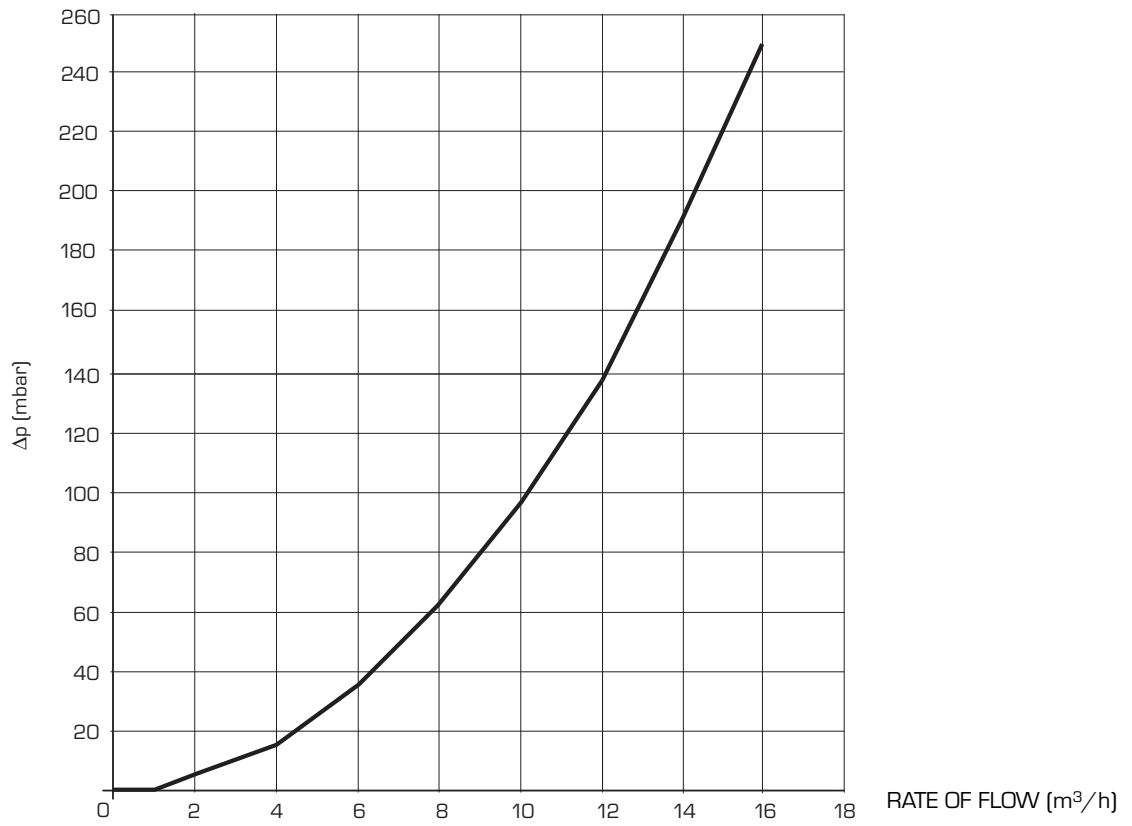

DEWY EQUIPE 300 - 360

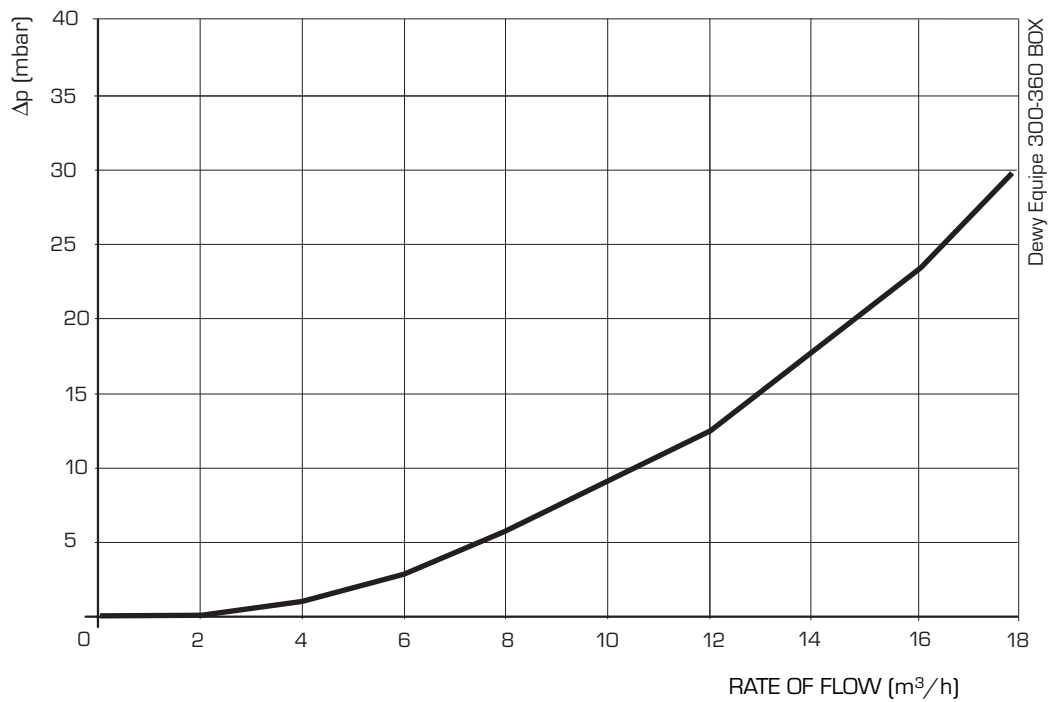
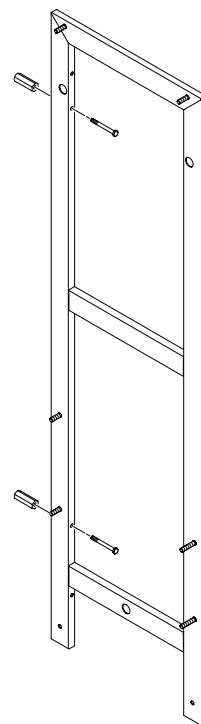

Fig. 3

1.6 CONTENTS OF KIT code 8102460 for "DEWY EQUIPE 120" - code 8102465 for "DEWY EQUIPE 180" - code 8102470 for "DEWY EQUIPE 240" - code 8102475 for "DEWY EQUIPE 300" - code 8102480 for "DEWY EQUIPE 360"

- N° 2 frame kit code 8103805 for "DEWY EQUIPE 120"
- N° 3 frame kit code 8103805 for "DEWY EQUIPE 180"
- N° 4 frame kit code 8103805 for "DEWY EQUIPE 240"
- N° 5 frame kit code 8103805 for "DEWY EQUIPE 300"
- N° 6 frame kit code 8103805 for "DEWY EQUIPE 360"



- N° 1 shelf kit code 8103810 per "DEWY EQUIPE 120-180"
- N° 2 shelf kit code 8103810 per "DEWY EQUIPE 240-300-360"

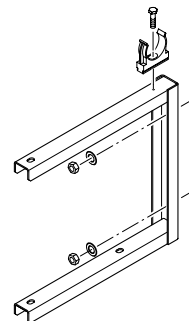

- N° 1 delivery/return and gas manifold kit code 8103815 coated in polyurethane with seal and M12 fixing screws for "DEWY EQUIPE 120"
- N° 1 delivery/return and gas manifold kit code 8103816 coated in polyurethane with seal and M12 fixing screws for "DEWY EQUIPE 180"
- N° 2 delivery/return and gas manifold kits code 8103815 for "DEWY EQUIPE 240"
- N° 1 delivery/return and gas manifold kit code 8103815 and N° 1 delivery/return and gas manifold kit code 8103816 per "DEWY EQUIPE 300"
- N° 2 delivery/return and gas manifold kits code 8103816 per "DEWY EQUIPE 360"

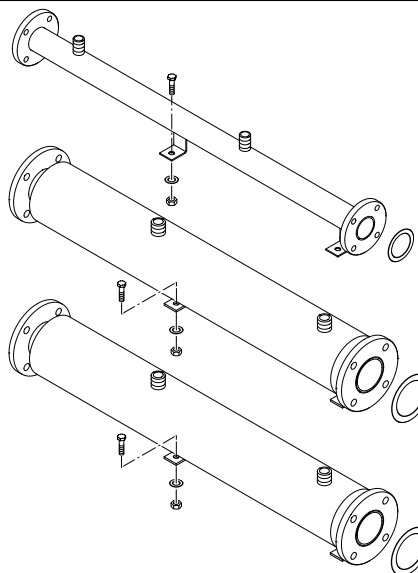

- N° 1 PN6 DN 50 and DN 80 blind flange kit code 8103820 with seals and fixing screws

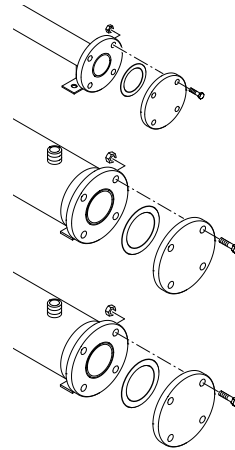

- N° 2 condensation drain manifold kits code 8103700 for "DEWY EQUIPE 120"
- N° 3 condensation drain manifold kits code 8103700 for "DEWY EQUIPE 180"
- N° 4 condensation drain manifold kits code 8103700 for "DEWY EQUIPE 240"
- N° 5 condensation drain manifold kits code 8103700 for "DEWY EQUIPE 300"
- N° 6 condensation drain manifold kits code 8103700 for "DEWY EQUIPE 360"

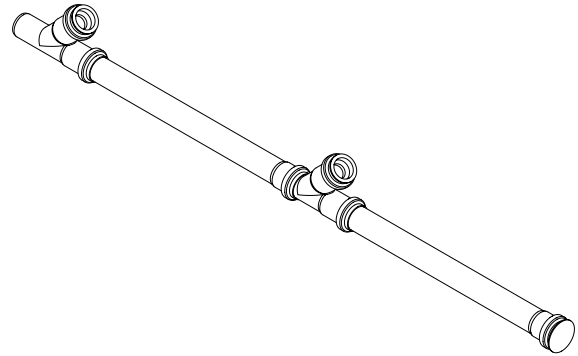

- N° 2 three-way delivery/return and gas cock kits code 8103800 with connecting pipes, 1" nipple and seals for "DEWY EQUIPE 120"
- N° 3 three-way delivery/return and gas cock kits code 8103800 with connecting pipes, 1" nipple and seals for "DEWY EQUIPE 180"
- N° 4 three-way delivery/return and gas cock kits code 8103800 with connecting pipes, 1" nipple and seals for "DEWY EQUIPE 240"
- N° 5 three-way delivery/return and gas cock kits code 8103800 with connecting pipes, 1" nipple and seals for "DEWY EQUIPE 300"
- N° 6 three-way delivery/return and gas cock kits code 8103800 with connecting pipes, 1" nipple and seals for "DEWY EQUIPE 360"

CAUTION: Before assembling three-way drain cocks, orient the ball regulation shaft as shown in the figure.

M Heating system delivery
R Heating system return
G Gas supply

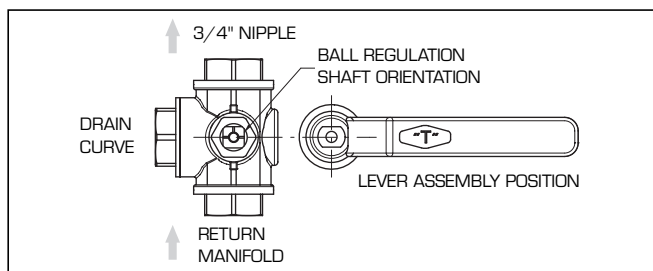
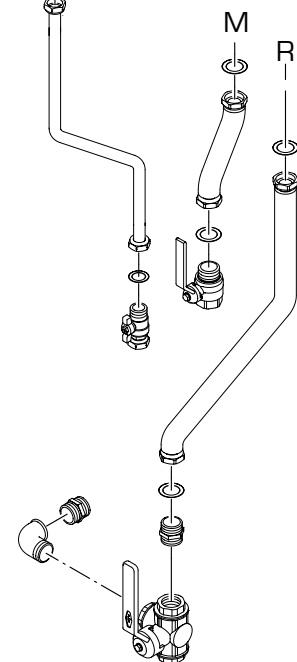

- N° 1 hydraulic compensator code 6216310 with seals, nuts and M12 fixing screws for "DEWY EQUIPE 120-180-240".

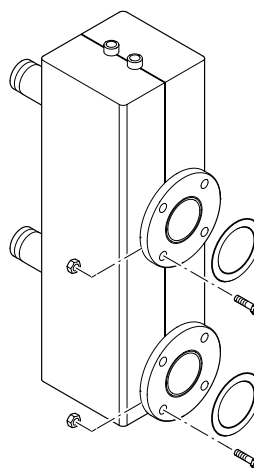

- N° 1 hydraulic compensator code 6216311 with seals, nuts and M12 fixing screws for "DEWY EQUIPE 300-360".

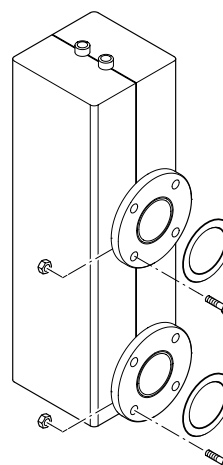

- N° 1 sequence/cascade kit RVA 47 code 8096311 for "DEWY EQUIPE 120-180-240" with instructions for assembly and electrical connection of boilers in cascade.
- N° 2 sequence/cascade kits RVA 47 code 8096311 for "DEWY EQUIPE 300-360" with instructions for assembly and electrical connection of boilers in cascade.

The kit is supplied complete with pull box, external probe QAC31, delivery/return cascade contact probes QAD21 and an immersion probe for use with an optional external hot water tank QAZ21.

CAUTION: To ensure correct functioning of the system, change the parameter configuration settings shown in the manual supplied with controller RVA 47.

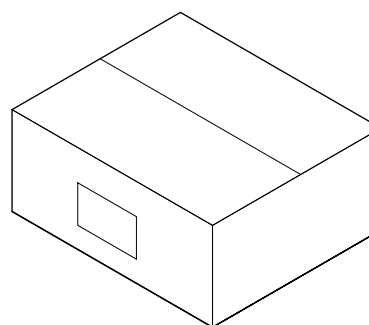

- Flue manifold for "DEWY EQUIPE 120-180-240"

FLUE MANIFOLD \varnothing 160
(kit A + B + B)

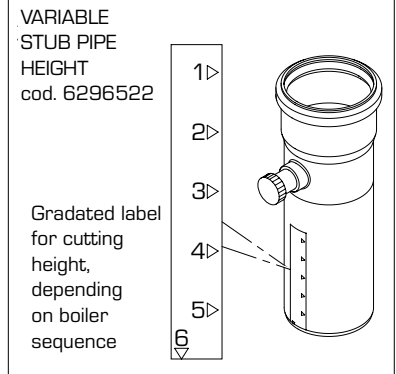
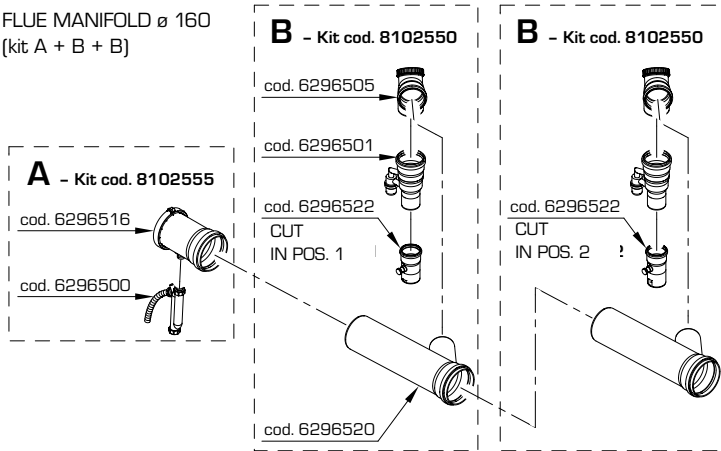

FLUE MANIFOLD \varnothing 160
(kit A + B + B + B)

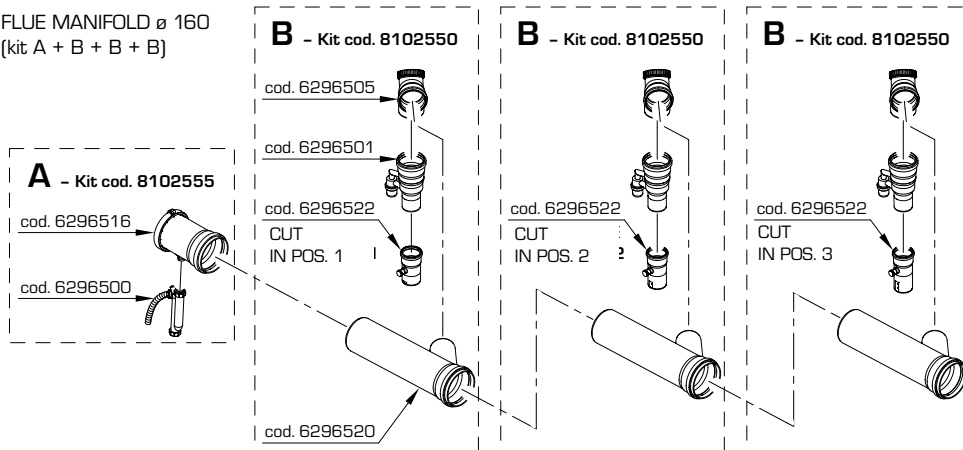

FLUE MANIFOLD \varnothing 160
(kit A + B + B + B + B)

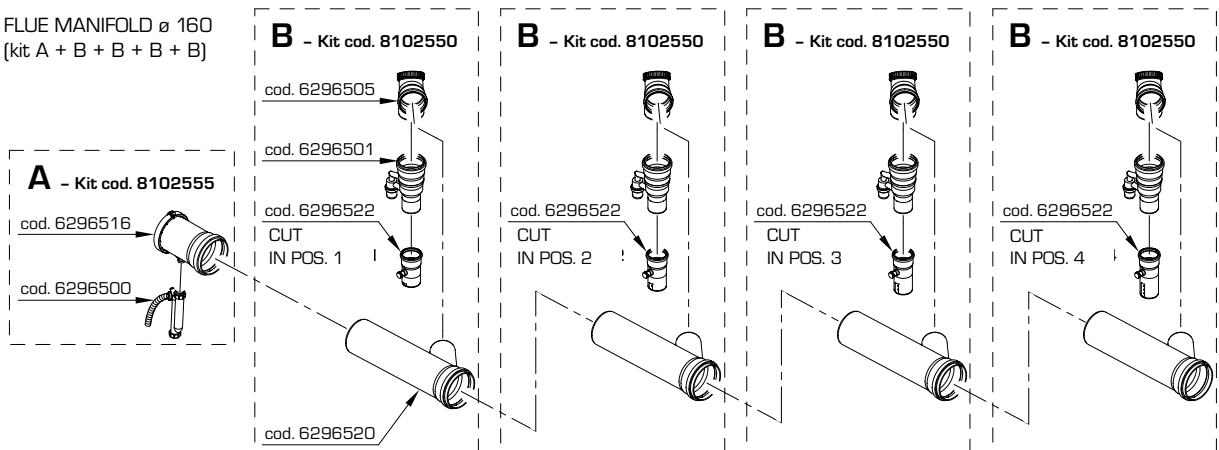

CAUTION:

- For easy connection of the elements making up the kit, apply the content of the tube supplied to the seals.
- Be careful to assemble the stub pipes of variable height (code 6296522) in the right order, depending on whether the manifold outlet is on the left or right side.

- Flue manifold for "DEWY EQUIPE 300-360"

FLUE MANIFOLD \varnothing 160/200
(kit A + B + B + B + B + C + D)

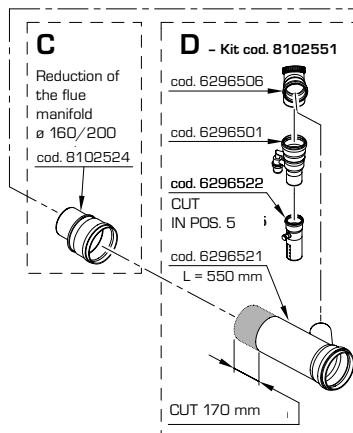
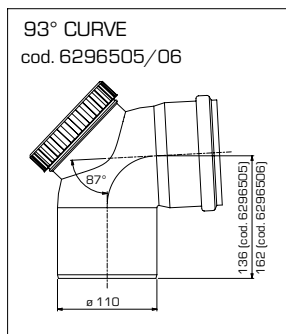
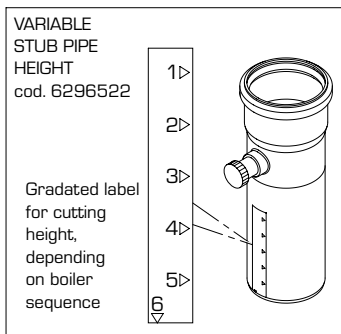
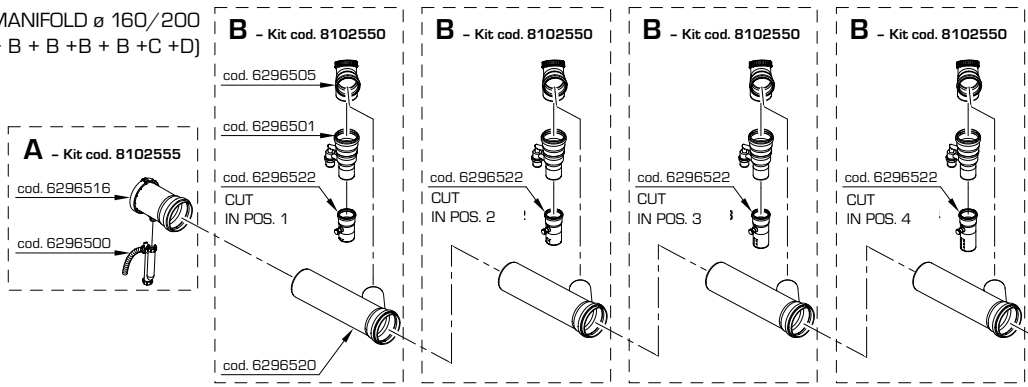

FLUE MANIFOLD \varnothing 160/200
(kit A + B + B + B + B + C + D + D)

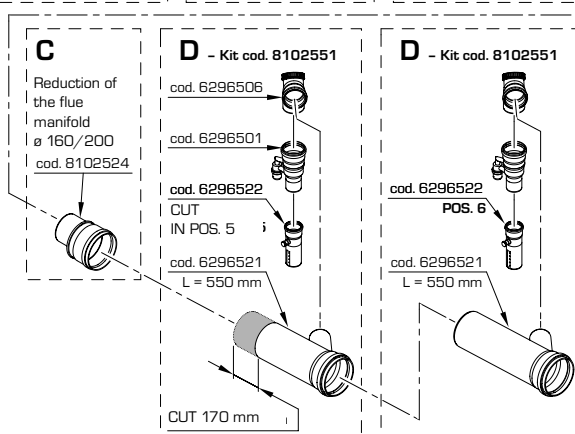
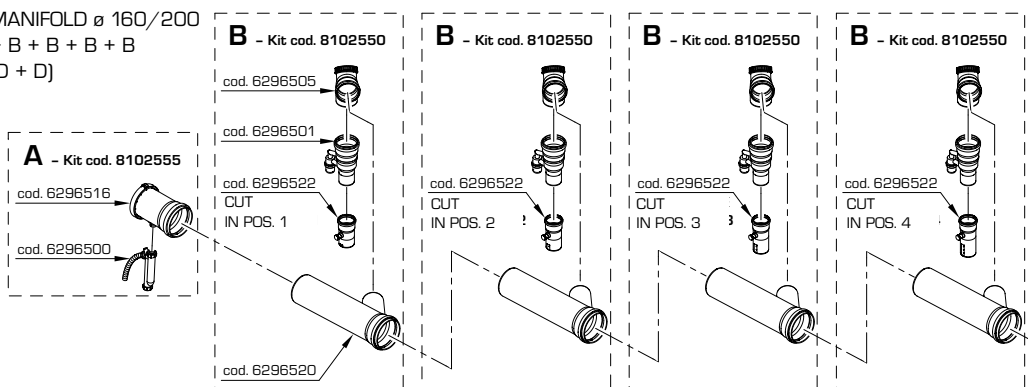

CAUTION:

- For easy connection of the elements making up the kit, apply the content of the tube supplied to the seals.
- Be careful to assemble the stub pipes of variable height (code 6296522) in the right order, depending on whether the manifold outlet is on the left or right side.

IT

ES

GB

FR

BE

1.7 DESCRIPTION OF SAFETY KIT (to be requested separately as appropriate to the layout of the connections)

- N° 2 flanged heating system delivery/return stub pipes complete with:
 - M16 seals, nuts and fixing screws
 - 0-120°C 1/2" thermometer code 6146004
 - 3.5 BAR safety valve code 6042203 and drain funnel code 6269402
 - 100°C safety thermometer with manual reset code 6001409
 - 4 BAR 1/4" water pressure switch code 6037550
 - 0-6 BAR 1/4" manometer code 6217050, cock code 6216606 and loop cod. 6216650
 - Expansion vessel, 8 liters, code 6245108, connection pipe, code 6227661, gaskets and nipple.

CAUTION:

Request kit code 8101511 for installations with connections on the right side.

Request kit code 8101510 for installations with connections on the left side.

For "DEWY EQUIPE 300-360" versions, request the safety valve kit code 8103825 complete with safety valve code 6242205 and drain funnel code 6269403 for use in place of safety valve code 6042203 and drain funnel code 6269402, which are included in the safety kit.

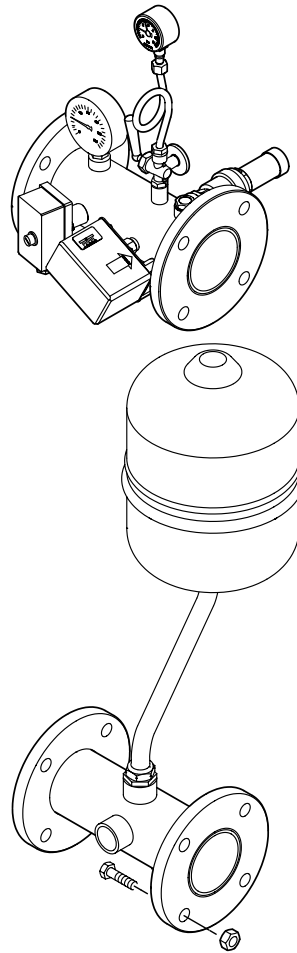

ASSEMBLY OF THE ISPEL SAFETY KIT IS OBLIGATORY

2 ASSEMBLING THE BOILER SUPPORT FRAME

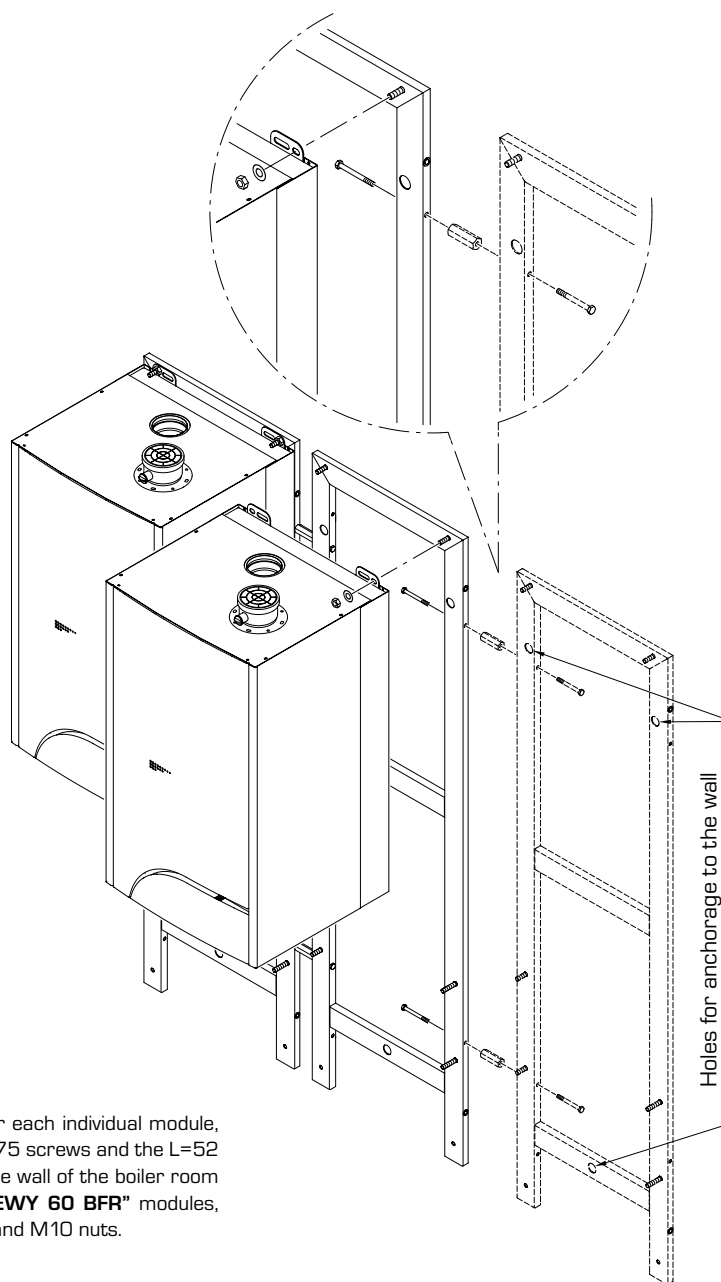

- 1 Position the supporting elements for each individual module, locking them together with TE M8 x 75 screws and the L=52 spacer. Fix the entire structure to the wall of the boiler room and hook up individual "PLANET DEWY 60 BFR" modules, locking them in place with washers and M10 nuts.

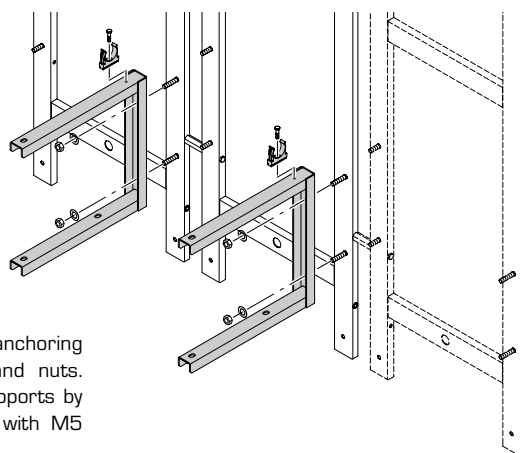

- 2 Assemble the manifold support brackets, anchoring them to the frame using M10 washers and nuts. Assemble the condensation drain manifold supports by anchoring them to the supporting brackets with M5 screws.

3 CONNECTING UP CONNECTIONS AND CONDENSATION DRAIN

IT

ES

GB

FR

BE

- 1 Insert the condensation drain manifold in its supports.
Connect the condensation drain from each boiler to the manifold.

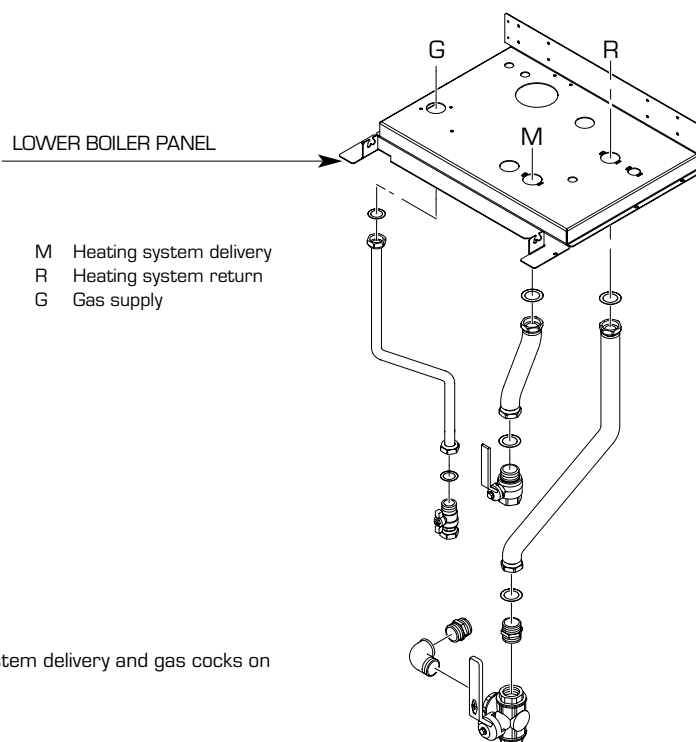
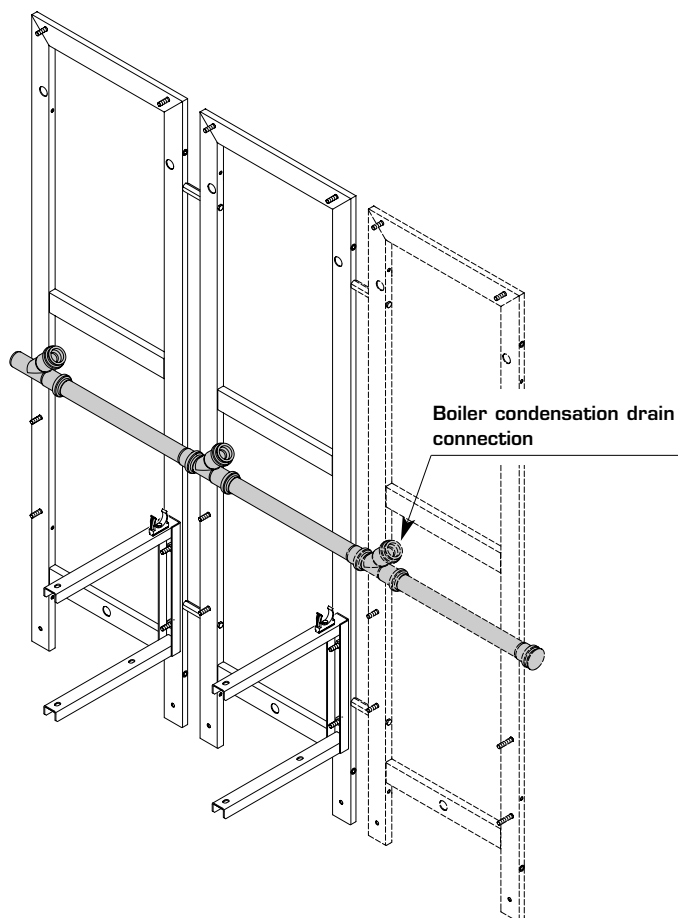

- 2 Assemble the set of heating system delivery and gas cocks on each boiler.

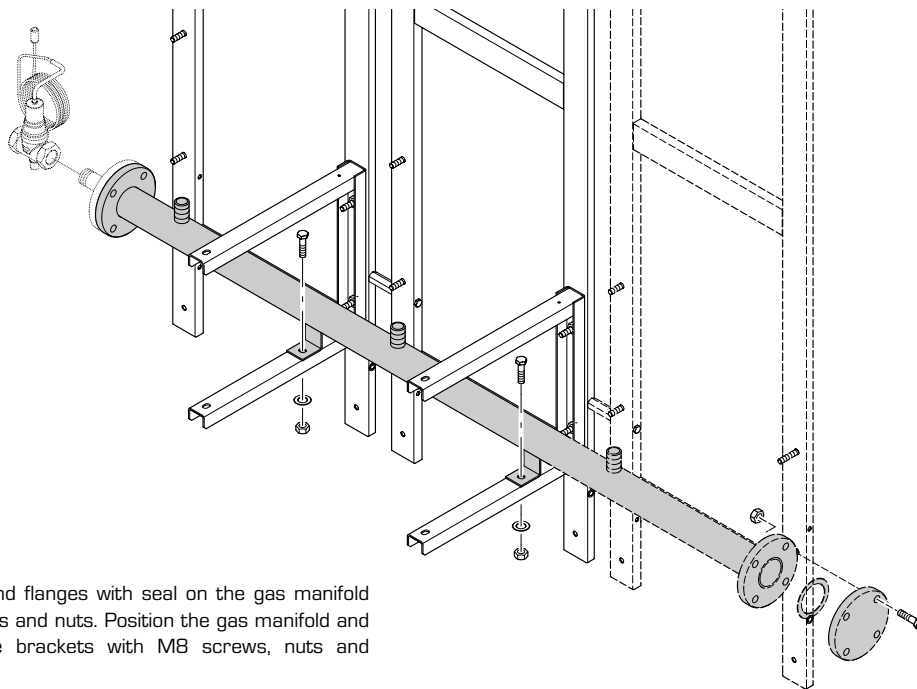

- 3** Assemble the blind flanges with seal on the gas manifold using M12 screws and nuts. Position the gas manifold and anchor it to the brackets with M8 screws, nuts and washers.

CAUTION: The qualified fuel on/off valve calibrated to 98°C is not supplied.

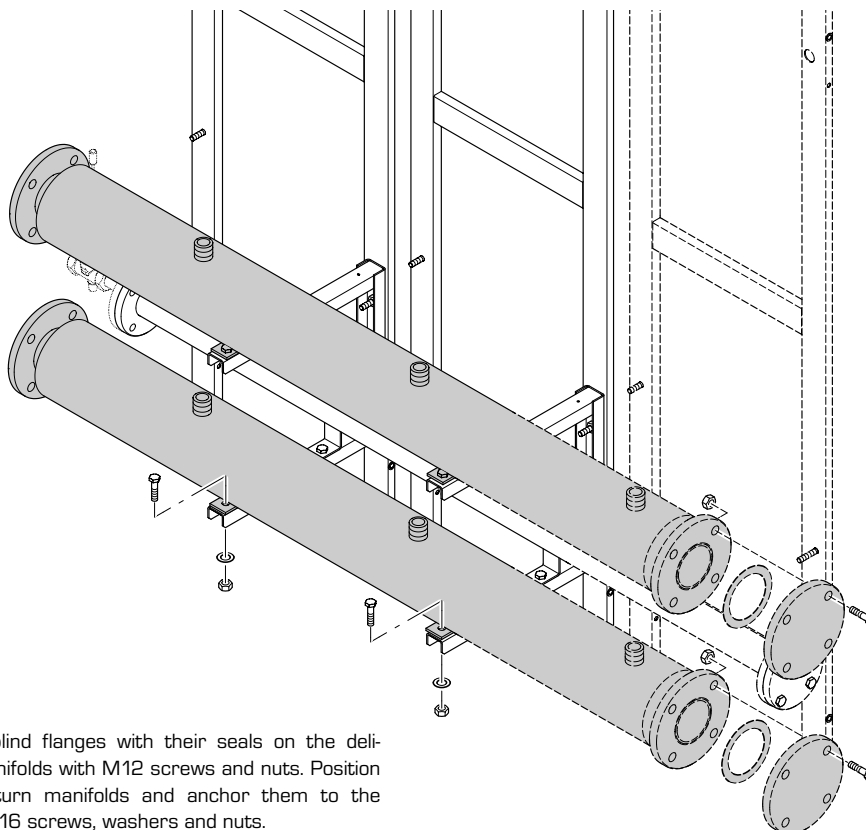

- 4** Assemble the blind flanges with their seals on the delivery/return manifolds with M12 screws and nuts. Position the delivery/return manifolds and anchor them to the brackets with M16 screws, washers and nuts.

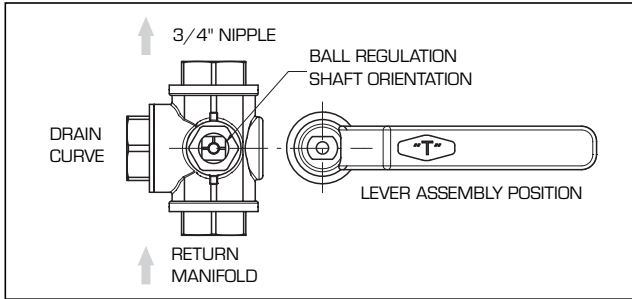
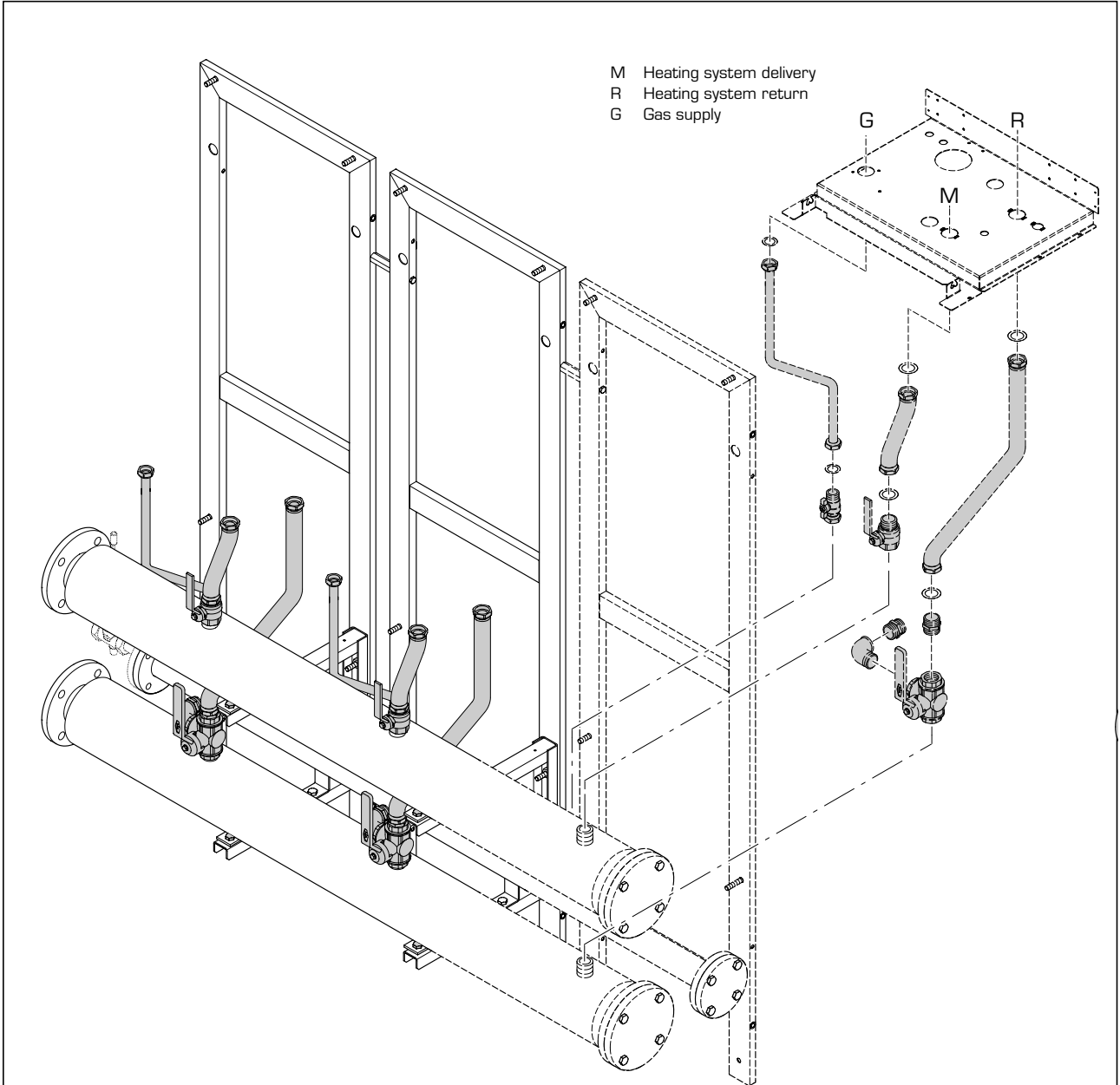

5 Assemble the series of three-way drain cocks and heating system delivery/gas cocks to the corresponding manifolds and connect up the pipes to the boiler connections with their seals.

CAUTION: Before assembling the three-way drain cocks, orient the ball regulation shaft as shown in the figure.

- 6** Connect up the safety kit supplied on request as appropriate for the position of the connections, on the left or right side. Assemble with seals and M12 fixing screws and nuts. Assemble the capillary of the fuel on/off valve qualified and calibrated to 98°C, not supplied, as shown in the figure.

ELECTRICAL CONNECTION

Serially connect the safety thermostat and the water pressure switch to the unit's electrical supply, as shown in the diagram on page 13.

CAUTION:

In "DEWY EQUIPE 300-360" versions, you must replace the safety valve and drain funnel with those supplied in kit code 8103825.

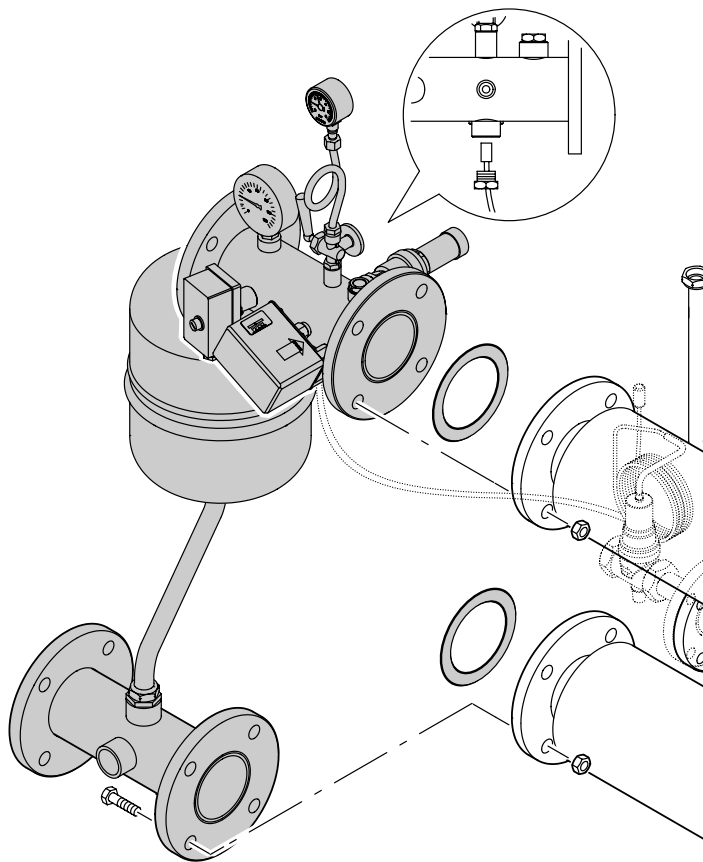

- 7** Assemble the hydraulic compensator: Use seals and anchor to stub pipes with M12 screws and nuts.

CAUTION: Assemble a 1/2" L. 50 sheath, a bleed valve and a drain cock, not supplied, on the hydraulic compensator in the positions shown in the figure.

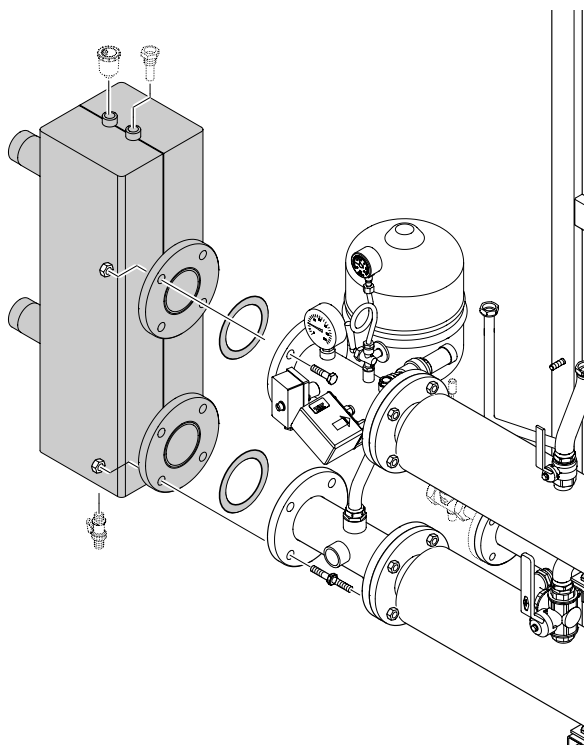

4 FLUE AND SEQUENCE/CASCADE UNIT

IT

ES

GB

FR

BE

- 1 Assemble the flue assembly. For easy coupling of the elements in the assembly, apply the contents of the tube supplied to the seals.
Be careful to assemble the stub pipes of variable height (code 6296522) in the right order, depending on whether the manifold outlet is on the left or right side.
Put the assembled flue assembly in position.
You may position the flue outlet on the left side if you turn the manifold by 180° and change the arrangement of the stub pipes of variable height (code 6296522).

CAUTION: The flue circuit must be scaled appropriately to ensure that the maximum pressure applied at the flue manifold outlet does not exceed 100 Pa.

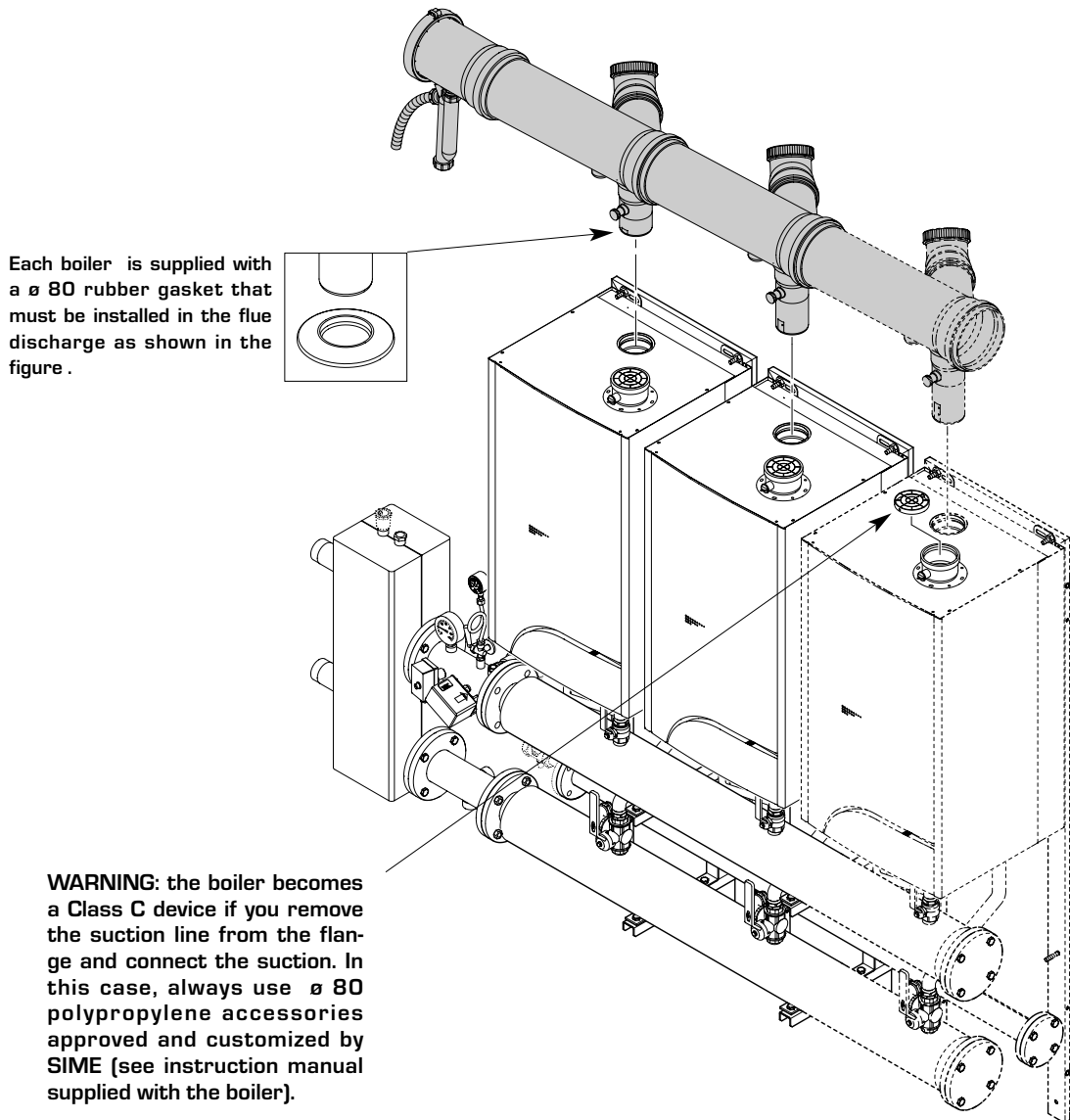

- 2 Complete the modular unit with installation and wiring of the sequence/cascade controller RVA 47. The controller is positioned inside a pull box, to be mounted on a wall in the boiler room. Instructions for assembly and use of the controller may be found in the kit code 8096311.

CAUTION: To ensure proper functioning of the system, adjust the configuration of the settings shown in the manual supplied with the sequence/cascade controller RVA 47.

5 ELECTRICAL CONNECTION OF BOILERS AND SAFETY KITS



1 Connect up the “DEWY EQUIPE 120-180-240” boilers, the water pressure switch (PA) and the safety thermostat (TS) assembled on the delivery stub pipe.

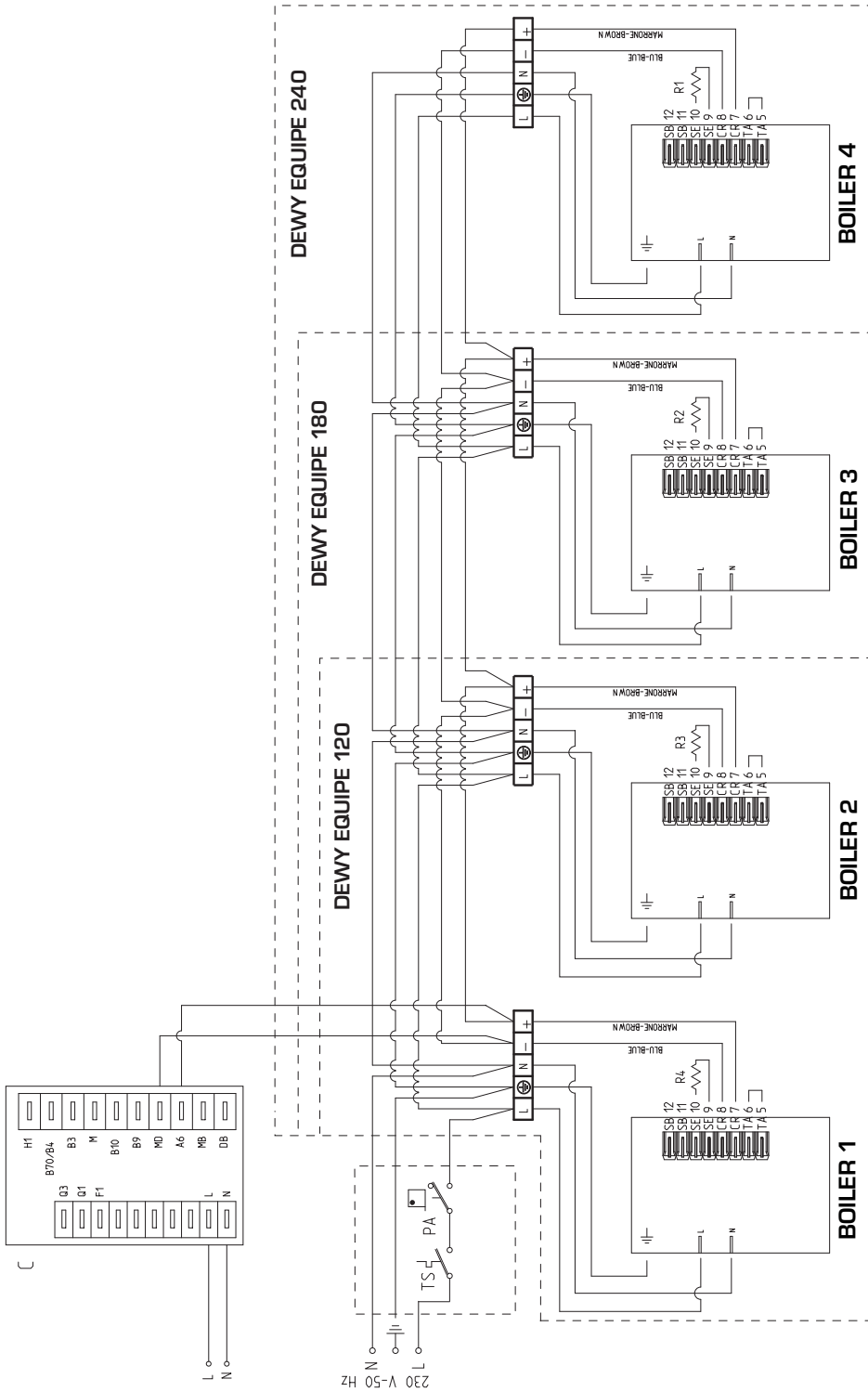

LEGEND
 L Line
 N Neutral
 TS 100°C Safety thermostat
 PA Water pressure switch
 C Controller RVA 47 with pull box
 R1 536 Ohm Heating element (1)
 R2 562 Ohm Heating element (1)
 R3 604 Ohm Heating element (1)
 R4 649 Ohm Heating element (1)
 (1) Heating elements are supplied in sequence/cascade kit RVA 47 code 8096311.

NOTE: When connecting other accessories to the controller RVA 47 (heating system pump, external temperature probe, cascade delivery probe, etc.), refer to the instruction manual supplied in the kit code 8096311.

2

Connect up the "DEWY EQUIPE 300-360" boilers, the water pressure switch (PA) and the safety thermostat (TS) assembled on the delivery stub pipe.

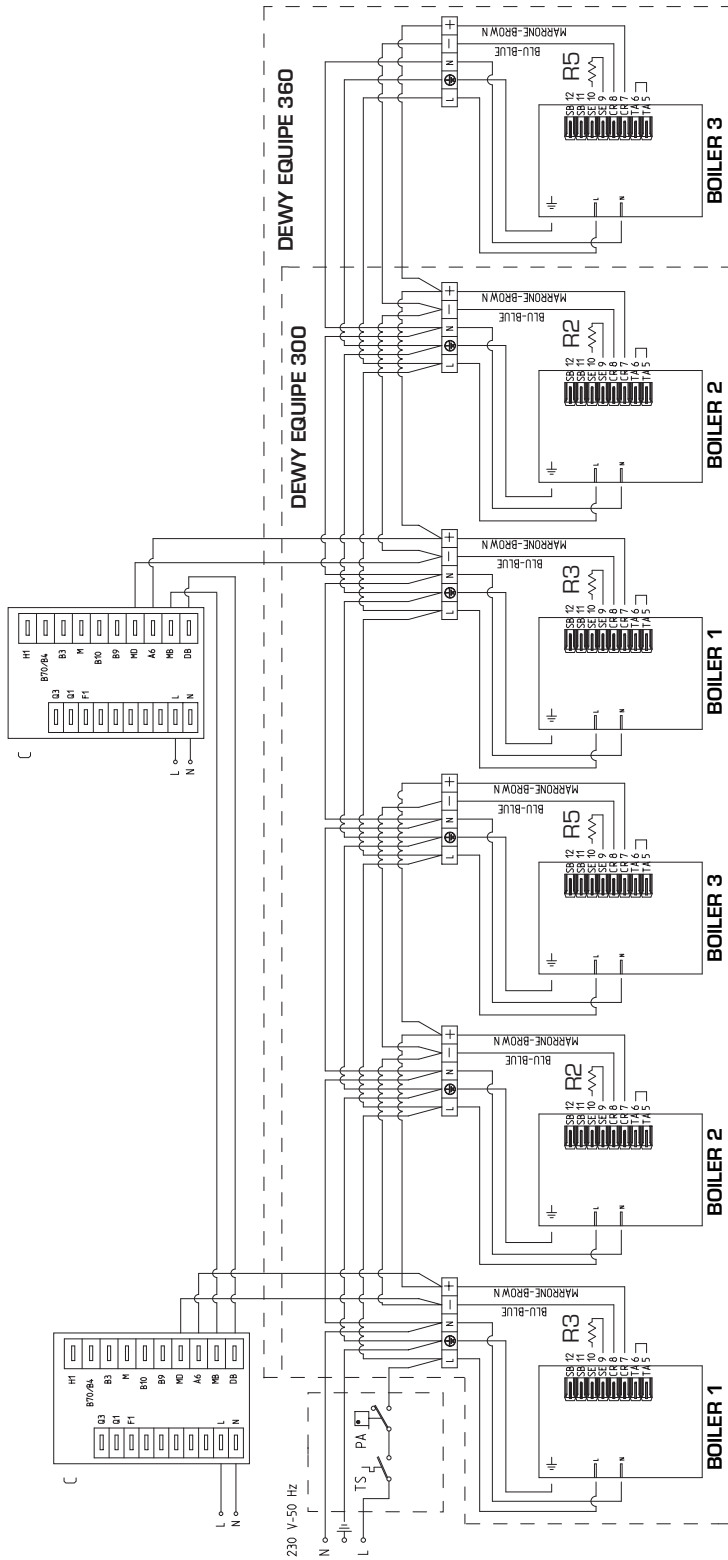

LEGEND
 L Line
 N Neutral
 TS 100°C safety thermostat
 PA Water pressure switch
 C RVA 47 controller with pull box
 R2 562 Ohm heating element (1)
 R3 604 Ohm heating element (1)
 R5 576 Ohm heating element (1)
 (1) Heating elements are supplied in the sequence/cascade kit RVA 47 code 8096311.

NOTE: When connecting other accessories to the controller RVA 47 (heating system pump, external temperature probe, cascade delivery probe, etc.), refer to the instruction manual supplied in the kit code 8096311.