



The Boiler People

INSTALLATION & SERVICING MANUAL FOR

50/70

**WALL MOUNTED BOILER
(INTERNAL)**

&

50/70

**WALL MOUNTED BOILER
(EXTERNAL)**

LEAVE THESE INSTRUCTIONS WITH THE END USER



BS 5750 PART 2
ISO 9002



CERT. No. FM 29884





The Boiler People

COMMISSIONING

***THIS APPLIANCE MUST
BE COMMISSIONED**

After commissioning ensure that the pre-paid warranty registration card is filled in and returned.

SERVICING

To ensure continued reliable operation and fuel economy it is recommended that the boiler is serviced annually.

Warmflow Engineering Service division provides an excellent back-up service, operating a team of Oftec trained engineers who can meet all the servicing, commissioning and breakdown requirements for your appliance.

Simply telephone

TEL: (028) 9262 0852

FAX: (028) 9262 2827

E-MAIL: service@warmflow.co.uk

*Failure to commission the boiler may invalidate warranty

Contents	Page
1.0 User Instructions	
1.1 Thermostat Control	2
1.2 Mains Indicator	2
1.3 Lock Out	2
1.4 Servicing	2
1.5 User Instructions – Wall Mounted (Internal)	3
1.6 User Instructions – Wall Mounted (External)	4
1.7.1 Components – Wall Mounted Boiler (Internal)	5
1.7.2 Components – Wall Mounted Boiler (External)	6
2.0 Introduction	
2.1 General Requirements	7
3.0 Dimensions	
3.1 50/70 Wall Mounted Boiler (Internal)	8
3.2 50/70 Wall Mounted Boiler (External)	8
3.3 Easy Fit Low Level Conventional Flue (LLF-R)	9
4.0 Installation Requirements	
4.1.1 Service Access for WM Boiler (Internal)	9
4.1.2 Servicing	9
4.1.3 Heating System	9
4.2 Sealed Systems	10
4.2.1 Air Vents	10
4.2.2 Drain Cock	10
4.2.3 Expansion Vessels	10
4.2.4 System Filling	10
4.2.5 Pressure Relief Valve	10
4.2.6 Low Pressure Switch	10
5.0 Boiler Installation	
5.1 Heat Exchanger Installation	11
5.2 Internal Boiler Casing Installation	12
5.3 External Boiler Casing Installation	13
5.4 Baffles	14
6.0 Electricity Supply	
6.1 RDB Burner Control Box	14
6.2.1 Control Panel Wiring (Wall Mounted Boilers – Internal)	15
6.2.2 Control Panel Wiring (Wall Mounted Boilers – External)	16
7.0 Technical Data	17
8.0 Air Supply	
8.1 Open Flue Boilers	18
8.2 Balanced Flue/Room Sealed Boilers	18
9.0 Flues	
9.1 Conventional Flues	19
9.2 Low Level Conventional Flue Positions	19
9.3 Low Level Conventional Flue Installation	21
9.4 Installation of Air Intake Duct	22
9.5 Wall Mounted Boiler (External) Flue Adaptor Installation	23
9.5.1 Option A	23
9.5.2 Option B	23
10.0 Oil Supply	
10.1 One Pipe System	24
10.2 Two Pipe System	25
10.3 De-aerator System	25
10.4 One Pipe Lift System	26
11.0 RDB Burner	
11.1 Components	27
11.2 Oil Pump	27
11.3 Air Damper Adjustment	28
11.4 Electrode Setting	28
11.5 Start-Up Cycle	28
12.0 Servicing & Commissioning	
12.1 Commissioning	29
12.2 Servicing	29
12.2.1 General Requirements	29
12.2.2 External Wall Mounted Boilers	29
13.0 Fault Finding	30
14.0 Spares	
14.1 Burner Spares	31
14.2 Short Parts List (Boiler)	32

User Instructions

All our domestic appliances have been independently tested and accredited as exceeding the minimum SEDBUK efficiency levels required for its type, in compliance with the Building Regulations Approved Document L1 2001 for England and Wales and the Building Standards (Scotland) Regulations 2001 Part J.

1.1 Thermostat Control

The recommended minimum thermostat is 65°C. Below this 'cold water corrosion' is likely to occur which can reduce the life of the heat exchanger and is not covered by the boiler warranty. The boiler thermostat is adjustable from 54°C to 84°C.

1.2 Mains Indicator

The green mains lamp will be lit when there is power to the control and limit thermostats.

The yellow high limit reset lamp will be lit when the boiler has overheated and tripped the high limit thermostat, which then needs to be manually reset. If the high limit thermostat continues to trip, contact Warmflow or your service engineer/technician. The manual reset thermostat has a cut out point of 110°C.

1.3 Lock Out

The red lock out lamp will be lit when the burner has failed to fire and can be reset by pressing the illuminated red reset button on the burner control box.

Note: On the external wall mounted boiler the thermostat control indication lamps and high limit reset button are located behind the lockable plastic cover.

1.4 Servicing

It is recommended that the boiler is serviced annually by an OFTEC registered engineer.

1.5 User Instructions – Wall Mounted (Internal)

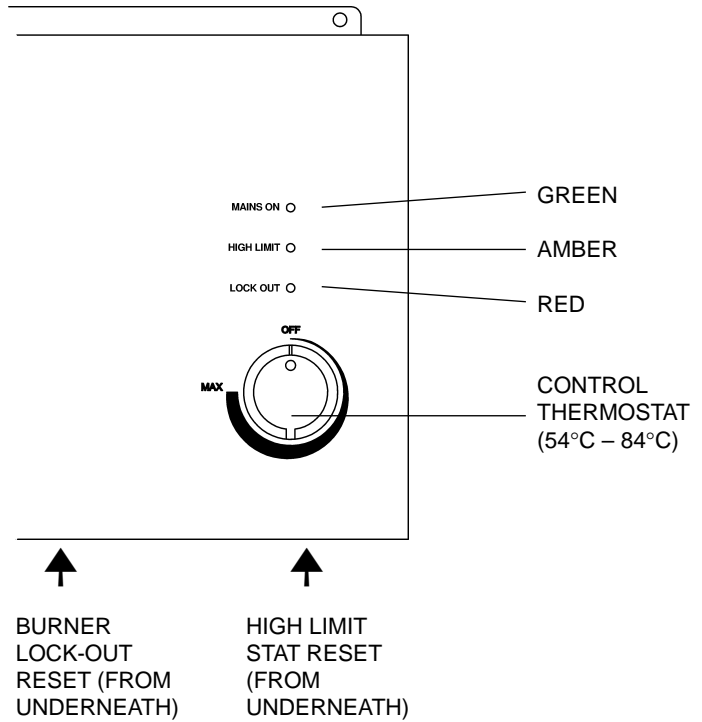
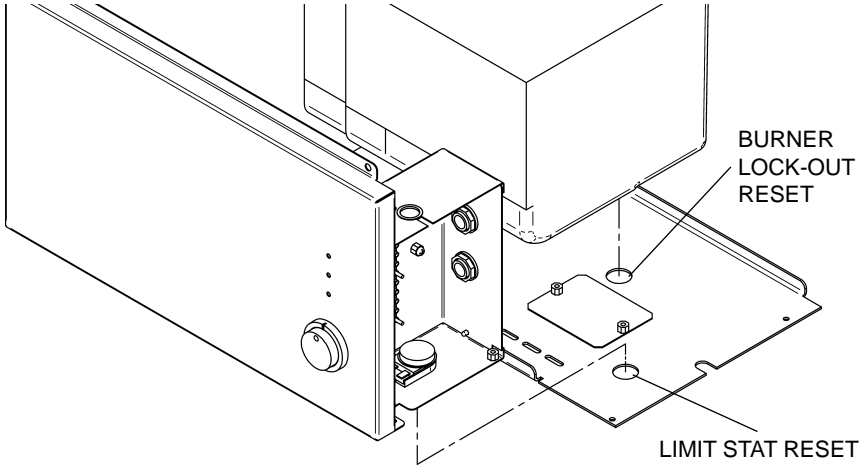

1.6 User Instructions – Wall Mounted (External)

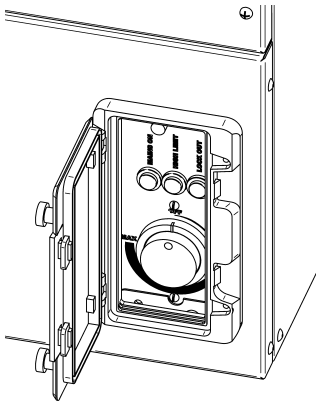
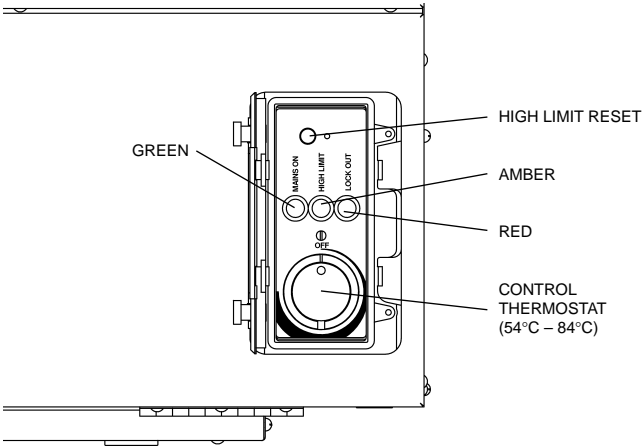
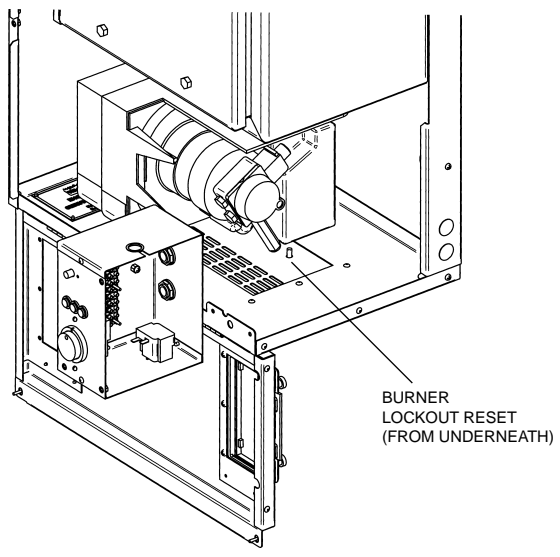

BURNER LOCKOUT RESET (FROM UNDERNEATH)

1.7 Components

1.7.1 Components – Wall Mounted Boiler (Internal)

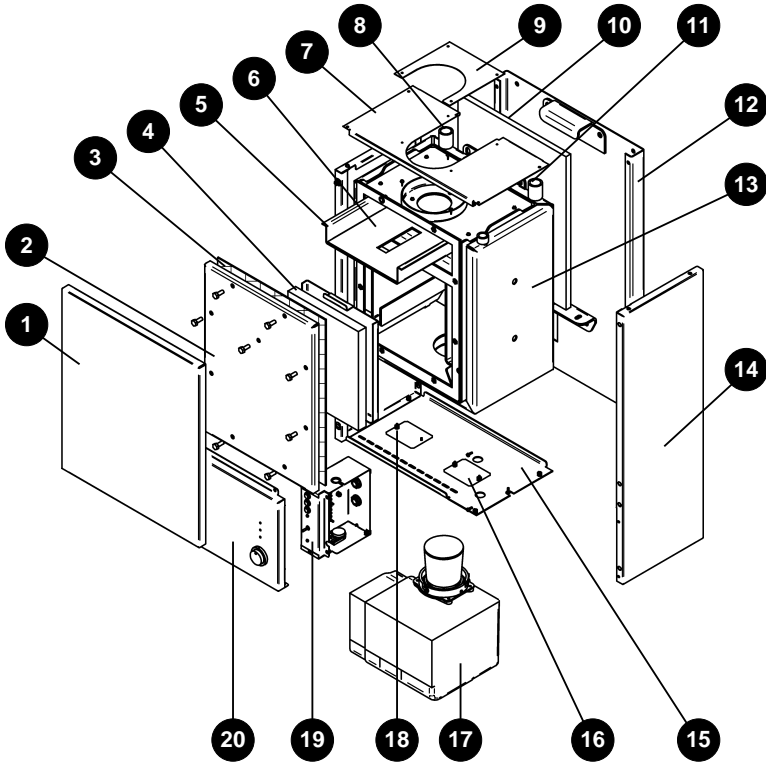

- | | | | |
|-----|-------------------------------------|-----|---------------------------------------|
| 1. | Front Casing | 11. | $\frac{3}{4}$ " BSP Return Connection |
| 2. | Combustion Chamber Door | 12. | Mounting Plate |
| 3. | Door Gasket | 13. | Heat Exchanger |
| 4. | Door Insulation | 14. | Side Casing |
| 5. | Top Baffle Support | 15. | Bottom Casing |
| 6. | Top Baffle | 16. | Oil Pump Access Plate |
| 7. | Top Casing & Insulation | 17. | Burner |
| 8. | $\frac{3}{4}$ " BSP Flow Connection | 18. | Air Damper Access Plate |
| 9. | Flue Closing Plate | 19. | Control Panel |
| 10. | Mounting Plate Insulation | 20. | Control Panel Casing |

1.7.2 Components – Wall Mounted Boiler (External)

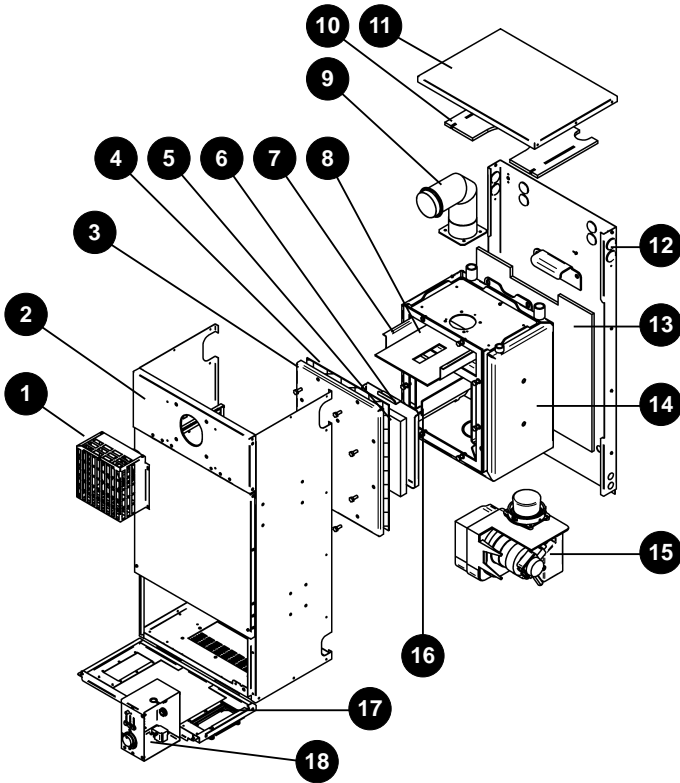

- | | | | |
|----|-------------------------|-----|---------------------------|
| 1. | Flue Terminal Guard | 10. | Top Insulation |
| 2. | Main Casing Assembly | 11. | Top Casing |
| 3. | Combustion Chamber Door | 12. | Mounting Plate |
| 4. | Door Gasket | 13. | Mounting Plate Insulation |
| 5. | Door Insulation | 14. | Heat Exchanger |
| 6. | Insulation Heat Shield | 15. | Burner |
| 7. | Top Baffle Support | 16. | Bottom Baffles |
| 8. | Top Baffle | 17. | Controls Inspection Flap |
| 9. | Flue Elbow | 18. | Control Panel |

2.0 Introduction

The boilers are fired by a pressure jet oil burner which is covered by the manufacturer's parts and labour warranty valid for one year (from boiler date stamp). Optional extended guarantees covering parts and labour are also available (although not applicable to the Republic of Ireland).

The Warmflow wall mounted oil fired boilers are designed to burn 28 second redwood No 1 (Kerosene Class C2) fuel.

The boiler shells are fabricated from the best quality mild steel plate electrically welded and pressure tested to 4.5 bar (65 PSIG) making them suitable for either open or pressurised systems (max working pressure 1.5 bar). They incorporate one flow and return connection on the top of the boiler for combined connection to the central heating and domestic hot water systems. Each shell is covered by the manufacturer's warranty of 5 years (effective from date stamped on warranty label) but does not include burner, labour, handling or shipping.

The manufacturer's guarantees are void if the appliance is not installed and commissioned and serviced in accordance with the recommendations made herein.

2.1 General Requirements

The installation of the boiler must be in accordance with the following regulations.

BS5410 : PART 1 : 1997 Code of Practice for oil firing.

BS5410 : PART 2 : 1997

BS5449 : PART 1 : 1977 Forced Circulation Hot Water Systems.

BS7593 : 1992 Treatment of water in domestic hot water central heating systems.

Current Building Regulations: Part J England and Wales
Part F Section III Scotland
Part L Northern Ireland

Current IEE Wiring Regulations:

The heating system should be installed by a competent installer in accordance with the recommendations laid down by HVCA and a sound engineering practice.

In order to comply with GB building regulations OFTEC Form CD10 for installations and CD11 for commissioning should be left with the customer.

3.0 Dimensions

3.1 50/70 Wall Mounted Boiler (Internal)

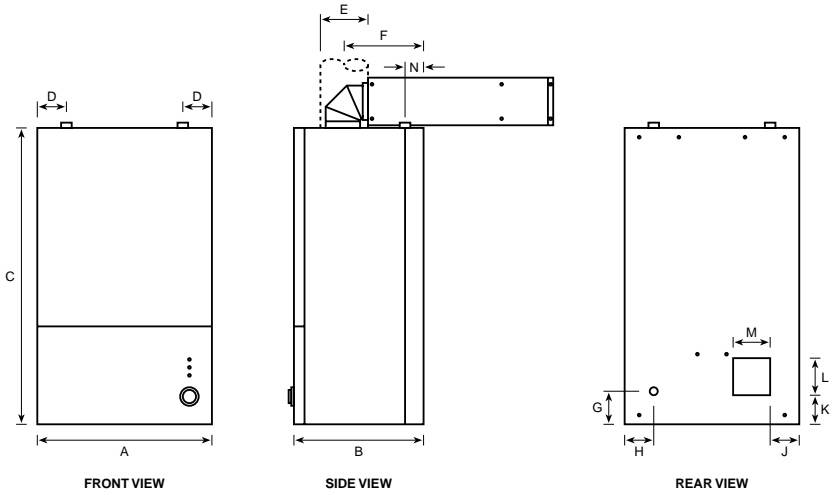

MODEL	A	B	C	D	E	F	G	H	J	K	L	M	N
50-70 WM	450	330	762	79	100	207	86	73	77	77	90	90	22

3.2 50/70 Wall Mounted Boiler (External)

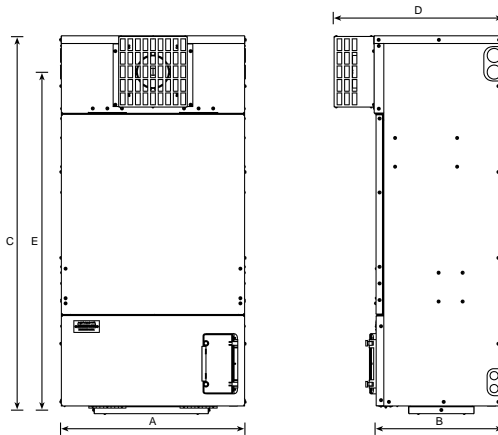

MODEL	A	B	C	D	E
50-70 WME	502	349	1023	465	926

It is recommended that the system is further treated with a corrosion inhibitor. These products should be used strictly in accordance with the manufacturer's instructions. In areas of hard water a suitable water softener would also be recommended.

4.2 Sealed Systems

All Warmflow boilers are suitable for use on a sealed heating system. It is recommended that a CE approved pressure relief valve (PRV) set at 3 bar is fitted to the system.

4.2.1 Air Vents

It is recommended that an air vent is fitted at the highest point in the system. However where the pipework comes off the boiler and drops down an automatic air vent should be fitted to the top of the boiler.

4.2.2 Drain Cock

Drain cock(s) should be fitted to the lowest points in the system to enable the system to be fully drained. A drain cock has been fitted to the boiler heat exchanger.

4.2.3 Expansion Vessels

Refer to BS 7074: part 1 or BS 5449 for details of the pressure vessel sizing. The values given in the table are for a total system values which includes the primary water capacity.

4.2.4 System Filling

Water loss from a sealed system, as indicated by a reduction in pressure on the pressure gauge, may be made up through a filling loop.

After filling, vent all air from the system. Ensure the caps on the automatic air vents are loose, bleed the circulating pump and disconnect the temporary filling loop. A system pressure, when cold, of 1 bar is recommended.

4.2.5 Pressure Relief Valve

The pressure relief discharge shall be positioned away from any electrical components. No other valves should be positioned between the relief valve and the discharge, and the discharge pipes should not be used for any other purposes. The discharge pipe must be plumbed to an external drain in a position where the discharge can be seen but cannot cause any injury or damage.

4.2.6 Low Pressure Switch

Where there is a catastrophic loss of water from the system the boiler thermostats may fail to operate which would result in serious damage to the appliance. To prevent this it is recommended that a low pressure cut out switch set at 0.2 bar is fitted to the system and wired in series with the boiler thermostats.

5.0 Boiler Installation

5.1 Heat Exchanger Installation

1. Make sure the wall chosen for the installation is flat level and able to support the filled weight of the appliance (128kg) and that the anchor bolts are appropriate for the wall.
2. Place the installation template on the wall making sure it is correctly positioned using a level. Once positioned drill the holes. Alternatively use the boiler mounting plate to locate the holes.
3. Fit the 4 No 6mm rawl plugs (not supplied) and using screws and washers fix the mounting frame to the wall. Insert the 2 lower anchor bolts (not supplied) and secure.
4. Fit the mounting plate insulation then insert the stripped down heat exchanger onto the mounting frame top first, up and under the retaining bracket (see Fig A below).

Note: Wall mounting of the boiler heat exchanger should only be carried out by two competent personnel.

5. With the heat exchanger in place fit the final 2 anchor bolts (not supplied) (see Fig B below) and secure the bottom bracket to the mounting frame using the 2 M8 nuts and bolts supplied (see Fig C below).
6. Connect the pipe work to the boiler and fit the flue.
7. The front door, baffles, burner, casings and control panel may now be fitted.
8. The power and oil supply can now be connected to the boiler.
9. Finish fitting the system making sure there are no leaks and all air has been bled from the system.
10. The boiler should now be commissioned.

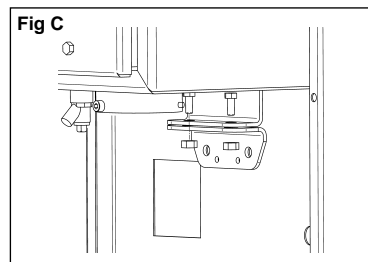
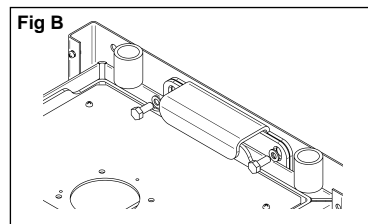
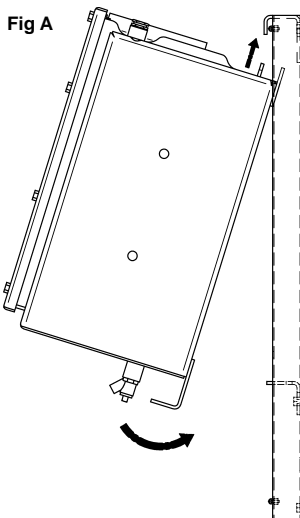

5.2 Internal Boiler Casing Installation

STAGE 1

Once the heat exchanger has been mounted on wall correctly a flue can be fitted. Insert 4 no M5 x 10 pozi head screws into the appropriate hank nuts on the wall bracket. Once in place attach the left and right hand casings using the keyhole slot on the rear of the panels and tighten screws to fix in place.

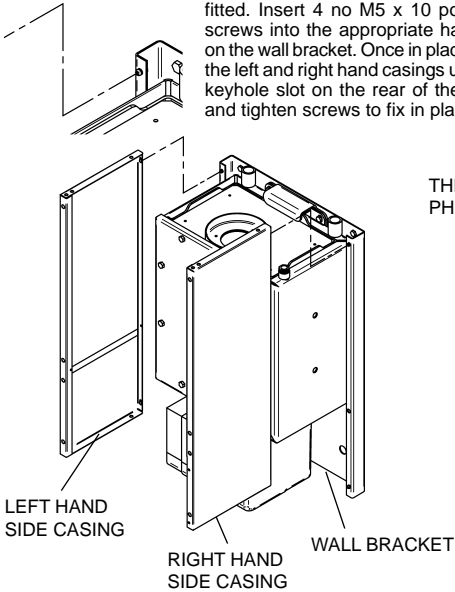

STAGE 2

Attach the control panel to the inside of the right hand side casing and fix in place using 3 no M5 x 10 pozi head screws. Ensure that the 2 no thermostat phials are inserted into the stat pocket on top of the boiler.

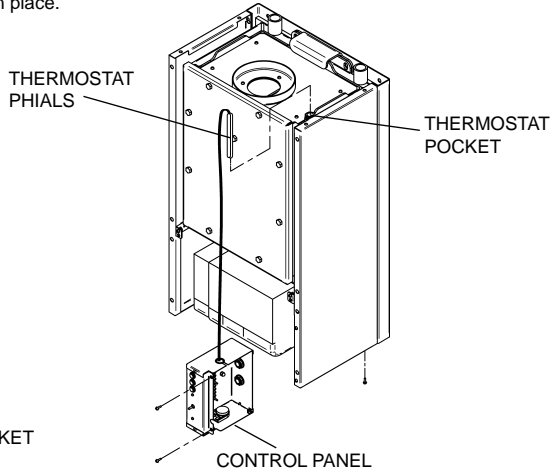

STAGE 3

Place the hood insulation on the top of boiler in appropriate position. Attach the top and bottom casings to the side casings using 8 no M5 x 10 pozi head screws. Attach the flue cover plate to the top casing using 4 no self tappers.

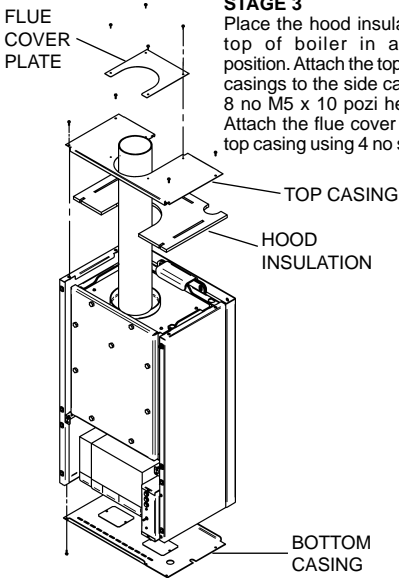

STAGE 4

Attach the control panel casing to the side casings and fix to the appropriate brackets using 4 no M5 x 10 pozi head screws. Attach the control stat dial to the spindle protruding the control panel casing. Attach the front casing to the side casings to complete the casing assembly.

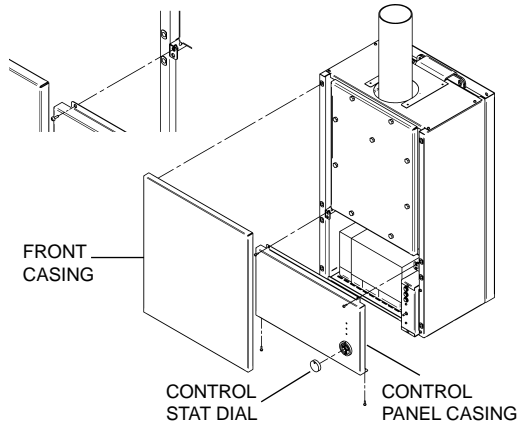

5.3 Wall Mounted Boiler (External) Casing Installation

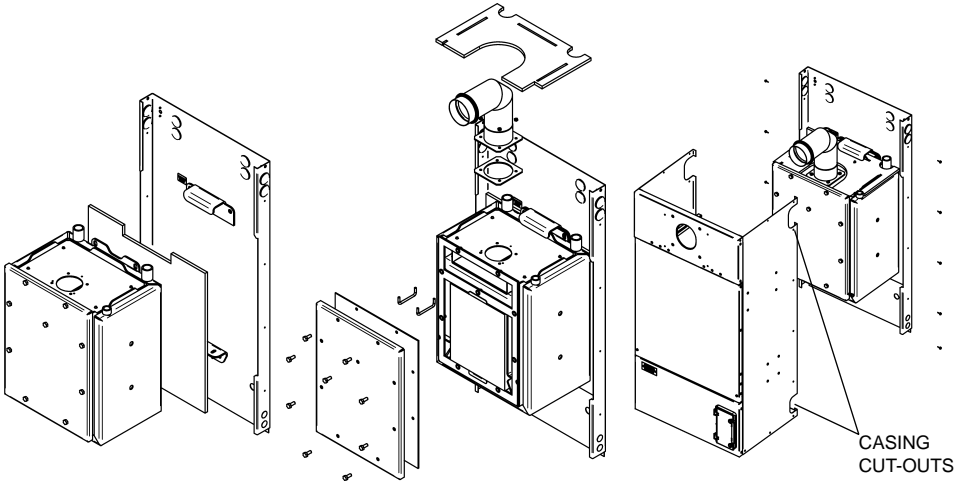

STAGE 1

Fit the wall-plate, boiler and flue as per internal wall mounted boiler instructions. The wall-plate for the external boiler can be used as a template.

STAGE 2

Fit the assembled casing onto the wall-plate using self tapping screws, ensuring the folds on the side panels hook in behind the wall-plate. Also ensure that the edges of the casing cut-outs have been sealed with silicone.

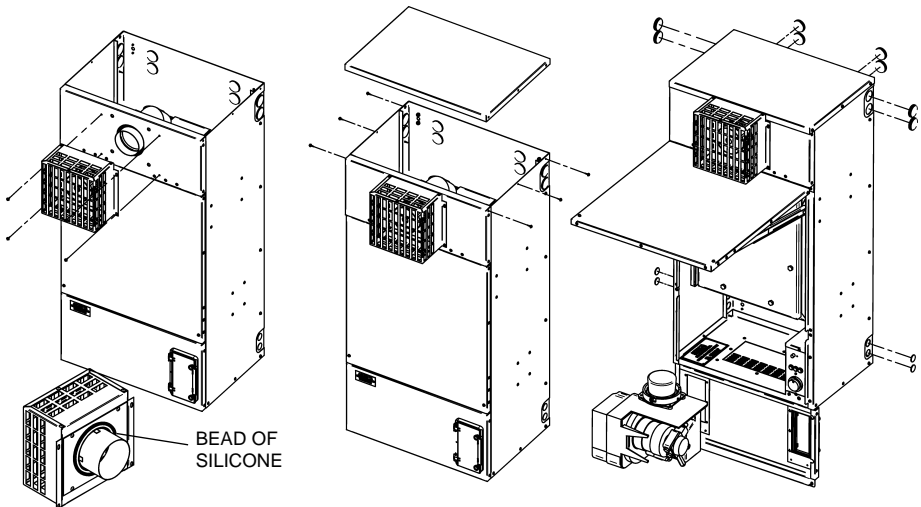

STAGE 3

Apply a bead of silicone to the flue terminal before fixing to the casing using 4 no self tapper screws. Fix the top casing panel to assembly using 6 no self tapping screws.

STAGE 4

Before fitting the burner to the boiler attach the 4 core cable to the burner control box. Finally insert the grommets into their appropriate holes on the wall-plate as shown above.

5.4 Baffles – Wall Mounted Boiler

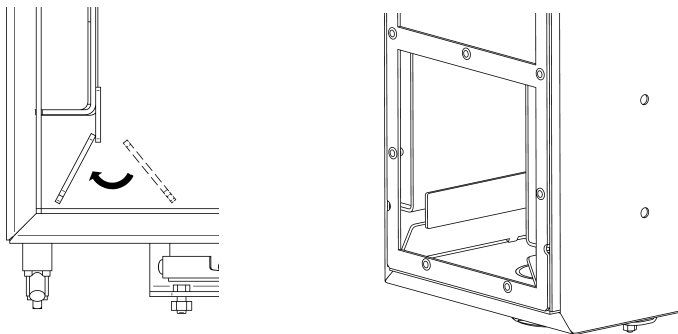

6.0 Electricity Supply

220 – 240V. 1PH, 50 Hz

The boiler should be wired via a fused double pole isolating switch which should be fitted with a 5 amp fuse. Additionally the external wall mounted boiler should be protected by a CE approved RCD. The external boiler requires a permanent live supply for the frost stat to operate.

It is the responsibility of the installer to ensure that the appliance has been properly earthed.

6.1 RDB Burner Control Box

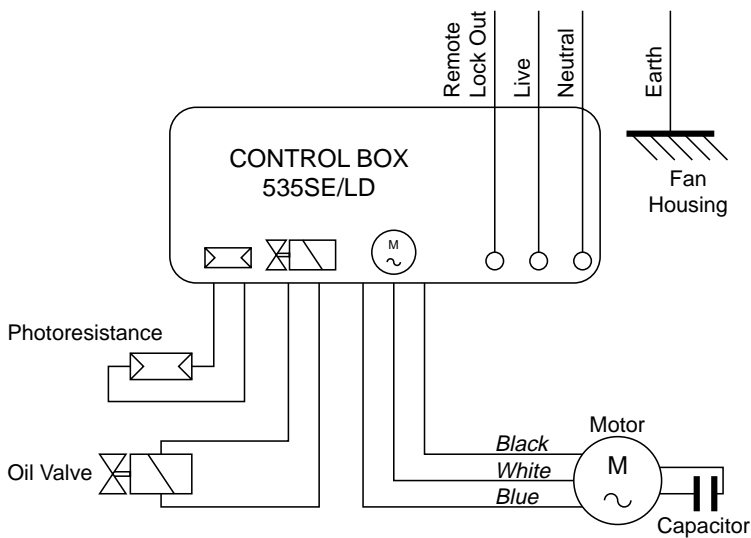

6.2.1 Control Panel Wiring (Wall Mounted Boilers – Internal)

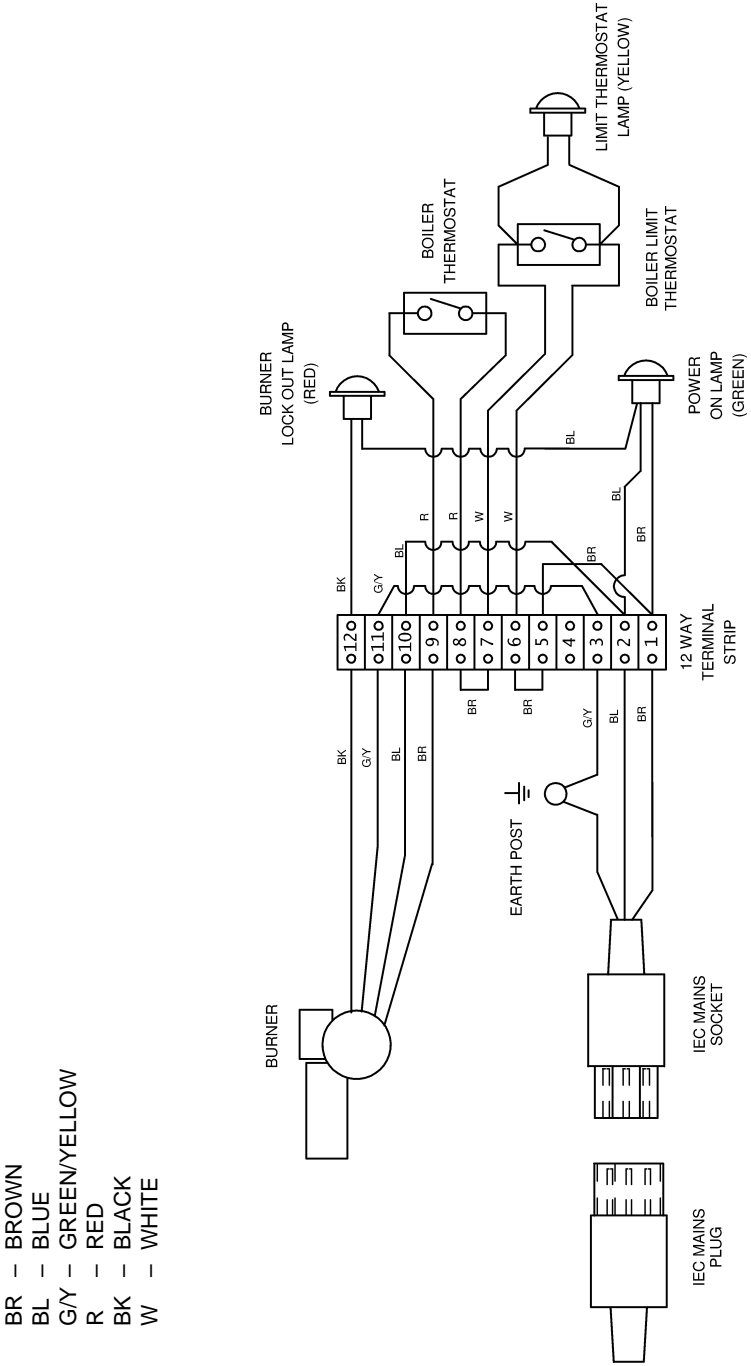

6.2.2 Control Panel Wiring (Wall Mounted Boilers – External)

Note: For normal operation the servicing switch should be in the off position otherwise the boiler will run continuously independently of the time clock.

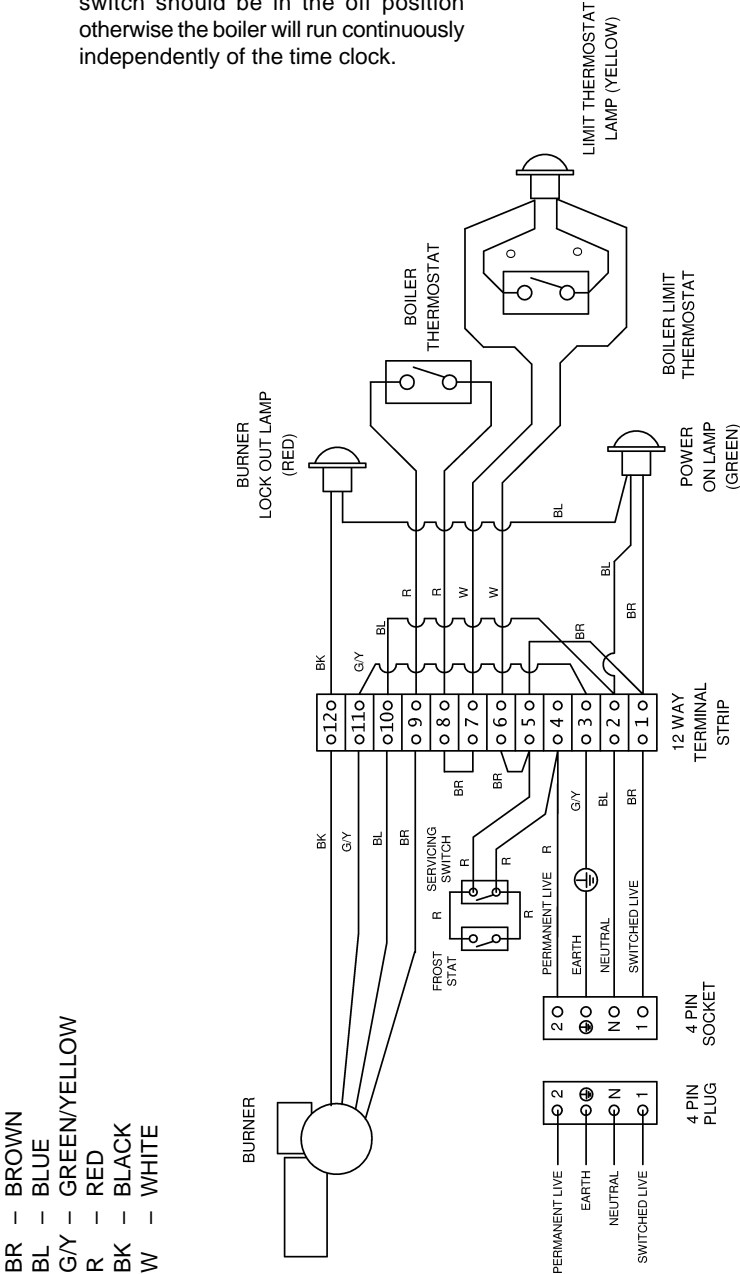

7.0 Technical Data

MODEL		50/70 WM & WM-E	
Output Range	kW	14.6 – 20.5	
RANGE SETTING		max	mid
Nominal Heat	kW	23.3	20.0
Input	Btu	79,600	68,200
Nominal Heat	kW	20.5	17.6
Output	Btu	70,000	60,000
Burner		RDB1	
Head		T2 Short	
Flue Size	mm	100 or 127	
Dia	in	4 or 5	
NFGT (max output)	°C	185	170
CO ₂		11.5	
Smoke	Bacarach	0 – 1	
Nozzle	make	Danfoss 60°S LE	
(Kerosine)	size	0.6	0.5
Pump	bar	8	8
Pressure	psi	116	116
Approx Fuel	L/h	2.4	2
Flow Rate	gals/h	0.53	0.44
Water Connections		2 x 3/4" BSP	
Water	litres	17.8	
Content	gallons	3.92	
Max Water	mbar	3.1	
resistance at 20°C T			
Max Water	mbar	21.0	
resistance at 10°C T			
Weight (empty)	kg	110	
Weight (full)	kg	128	
Sedbuk Band		C	C

8.0 Air supply for combustion and ventilation (see BS 5410)

8.1 Open Flue Boilers

When the boiler is sited in a cellar where the only access for combustion and ventilation air is at high level then the combustion air should be ducted to low level.

Combustion Air Supply

Boiler in Room

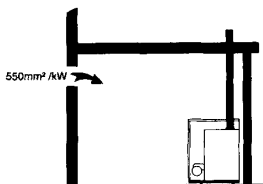

OPEN FLUE

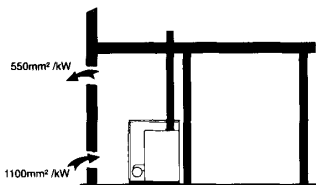

OPEN FLUE
COMPARTMENT
VENTILATED FROM OUTSIDE

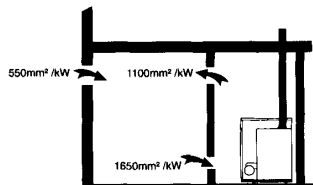

OPEN FLUE
COMPARTMENT
VENTILATED FROM ROOM

8.2

Balanced Flue/Room Sealed Boilers

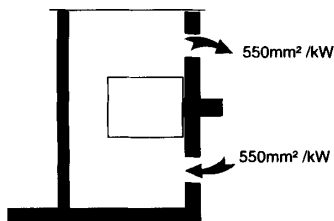

VENTED FROM OUTSIDE

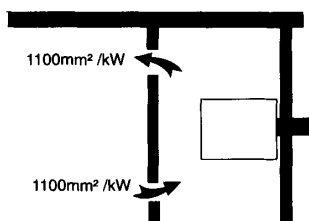

VENTED FROM ROOM

Air Supply for Ventilation

9.0 Flues

9.1 Conventional Flues

The flue should be designed in accordance with the local bye-laws and the Clean Air Act. Draught stabilisers are not recommended for oil fired boilers. Sharp bends or horizontal runs should be avoided and the flue should terminate 2 feet (600 mm) above the ridge of the dwelling. Terminals which restrict the discharge or allow ingress of water should be avoided.

It is recommended that when connecting to an existing masonry chimney a flexible stainless steel liner should be used. The annular space must be sealed top and bottom and loosely filled with insulation.

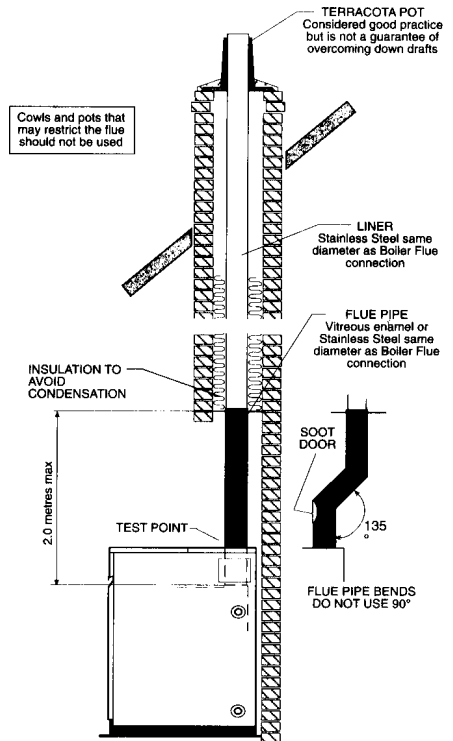

Typical Conventional Flue with Brick Chimney

9.2 Low Level Conventional Flue Positions

Attention should be given to the position of the flue discharge; we recommend the following guidelines be adopted.

1. The flue should not discharge beneath opening windows or within 2 metres of other accesses to the building.
2. The flue should not discharge near internal/external corners of the building where turbulent wind conditions could occur.
3. The terminal should not discharge over property boundaries.
4. Discharge into narrow passageways should be avoided.
5. In positioning the flue the wind direction should be considered.
6. The actual siting of the flue should be determined by the installer after consultation with the householder.

INSTALLATION IN EXPOSED POSITIONS IS NOT RECOMMENDED

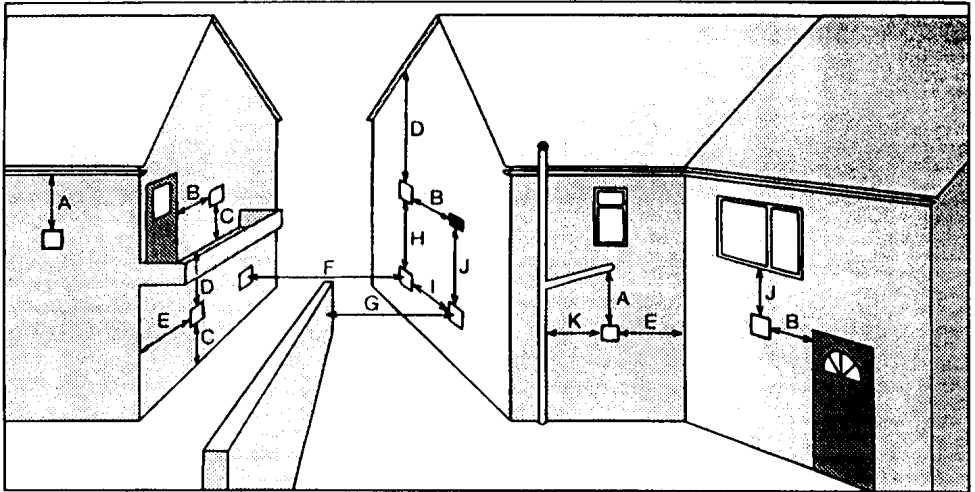

Terminal Position	Min Distance	
A	Below gutters, soil pipes or drain pipes	1,000
B	From a door, window or air vent	600
C	Above ground, flat roof or balcony level	600
D	Below eaves or balconies	1,000
E	From an internal or external corner	600
F	From a terminal facing the terminal	600
G	From a surface facing the terminal	600
H	Vertically from a terminal on the same wall	1,500
I	Horizontally from the terminal on the same wall	600
J	Directly below an opening, air brick, window, etc.	600
K	From a vertical drain pipe or soil pipe	1,000
L	From a vertical structure on the side of the terminal	750

These are minimum dimensions and are only quoted as a guideline but they will satisfy the requirements of all UK Building regulations.

Where the flue terminal is within 1 metre of any plastic material, such material should be shielded from the effects of the combustion products of the flue.

9.3 Installation of a Low Level Conventional Flue (LLF-R)

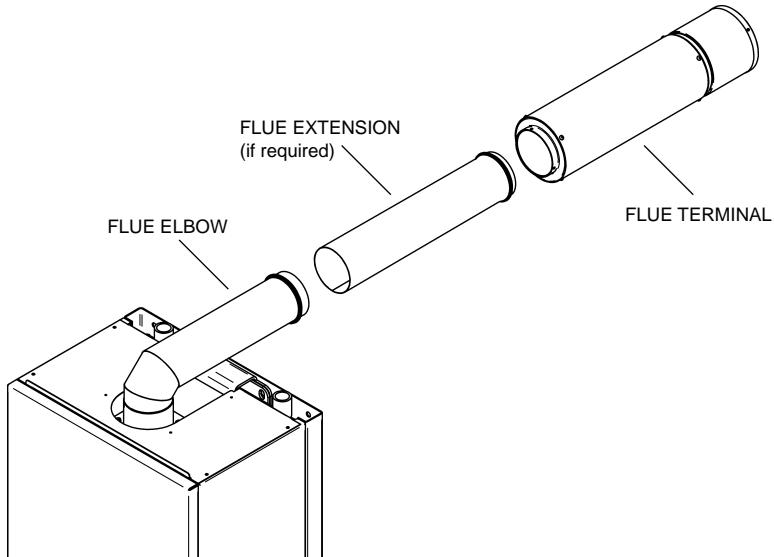

1. Make a suitable sized hole in the wall for the flue kit. Using the paper template provided. The cavities must be sealed from the hole.
2. Remove the top panel (kitchen and utility models) and the combustion chamber lid.
3. Remove the flue ring from the top of the boiler (3 screws) ensuring that any remaining silicone sealant has been cleaned away.
4. Carefully fit the inner seal to the flue elbow.
5. Slide on the extension piece (if required) ensuring that the seal has been fitted to the end of the extension. Only one extension piece may be utilised.

Note: After fitting the seal to the flue smear them with soap or any lubricant which does not react with the silicone rubber.

6. Place the gasket correctly on the boiler and locate the flue elbow over this, fixing it in position using the nuts and bolts provided.
7. Slide the flue terminal into position with a twisting movement ensuring that it protrudes through the wall by a minimum of 155mm and a maximum of 225mm.
8. Seal the gap between the flue and the wall both inside and out after which the protective basket may be fitted to the wall over the flue terminal.

9.4 Installation of Air Intake Duct (Internal Boiler Only)

The wall mounted boiler when fitted with a conventional flue or low level conventional flue can be made room sealed by fitting an air intake duct (rear outlet only).

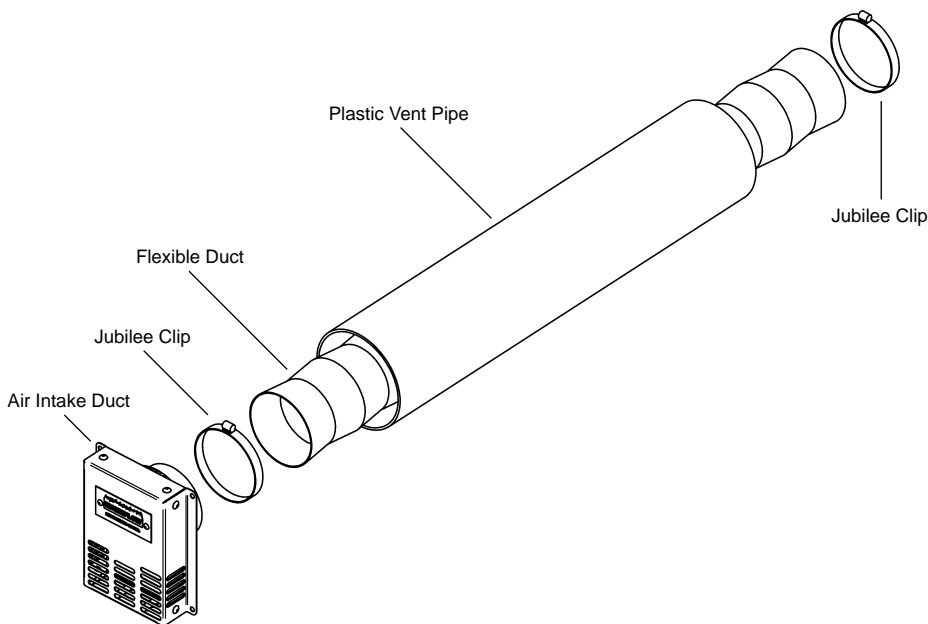

1. Using the template supplied cut a 4" hole through the wall, minimum 300mm above the ground.
2. Cut plastic vent tube to suit wall thickness and insert into the hole in the wall.
3. Remove plastic air inlet cover on the burner. Attach the air intake gasket and adapter to the burner using the screws supplied.
4. Attach one end of the flexible duct to the burner air intake adapter using 1 no 3" jubilee clip as supplied.
5. Feed the flexible duct through the plastic vent tube to the outside of wall and fix to the air intake duct using the remaining jubilee clip, cut the flexible duct to a suitable length ensuring adequate length for rotation of burner during removal.
6. Once flexible duct is attached to the air intake duct, insert into the vent tube and fix it to the wall using appropriate fixings. Ensure the perforated side of the air intake duct is facing downwards.

9.5 Wall Mounted Boiler (External) Flue Adaptors

9.5.1 Fitting Vertical Flue Adaptor (Option A)

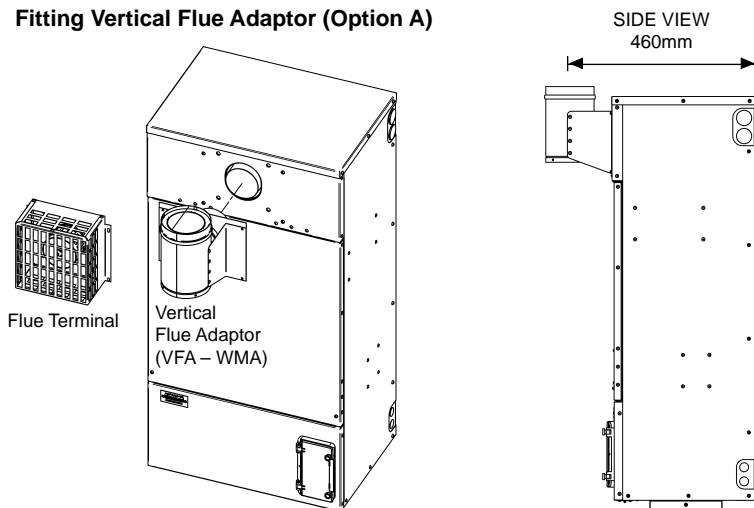

Remove the flue terminal (4 screws) and fit the vertical flue adaptor as shown (4 screws).

9.5.2 Fitting Vertical Flue Adaptor (Option B)

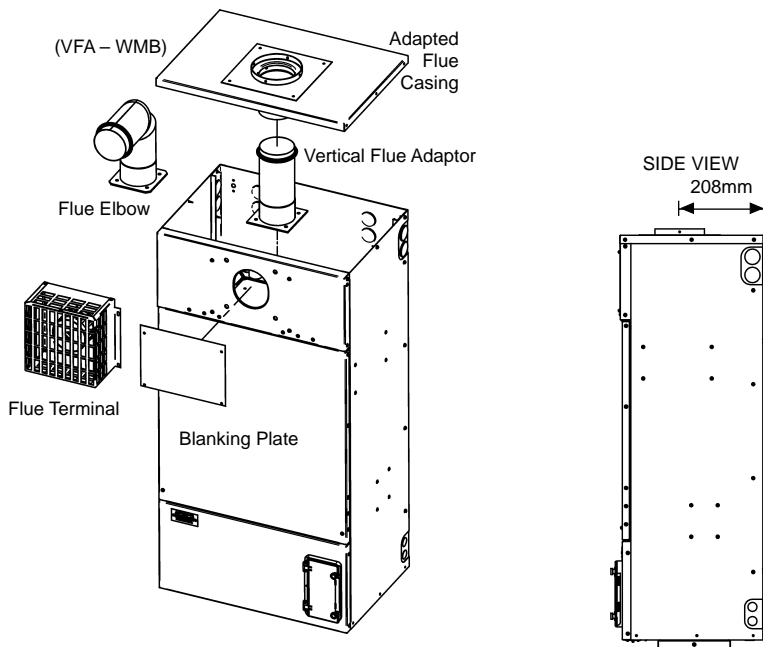

Remove the flue terminal and cover the hole with the blanking plate (4 screws). Remove the top casing. Remove the flue elbow and fit the vertical flue adaptor and adapted flue casing.

10.0 Oil Supply

1. Oil Tank

Steel tanks constructed to BS 799 Part 5 1987 should be painted on the outside only and mounted on piers to prevent corrosion. Plastic oil tanks are also available and can be suitable for installation at ground level. However, kerosene should never be stored in translucent plastic containers.

- The pipe from the oil tank to the burner should be run in copper, steel or aluminium pipework. Galvanised pipe and fittings should not be used. The pipework should terminate close to the boiler and be fitted with an isolating valve and filter. It is also recommended that a remote sensing fire valve should be fitted to the oil line where the oil line enters the building (BS5410).

The fire valve can be connected to the warranty label bracket on Deluxe and Whitebird boilers using 2 cable ties or by attaching a clip to the boiler casing on Bluebird models.

Depending on the position of the tank a two pipe system may be required. One and two pipe oil systems are shown below. As an alternative to a two pipe system a Tigerloop or other approved de-aerator may be used.

10.1 One Pipe System

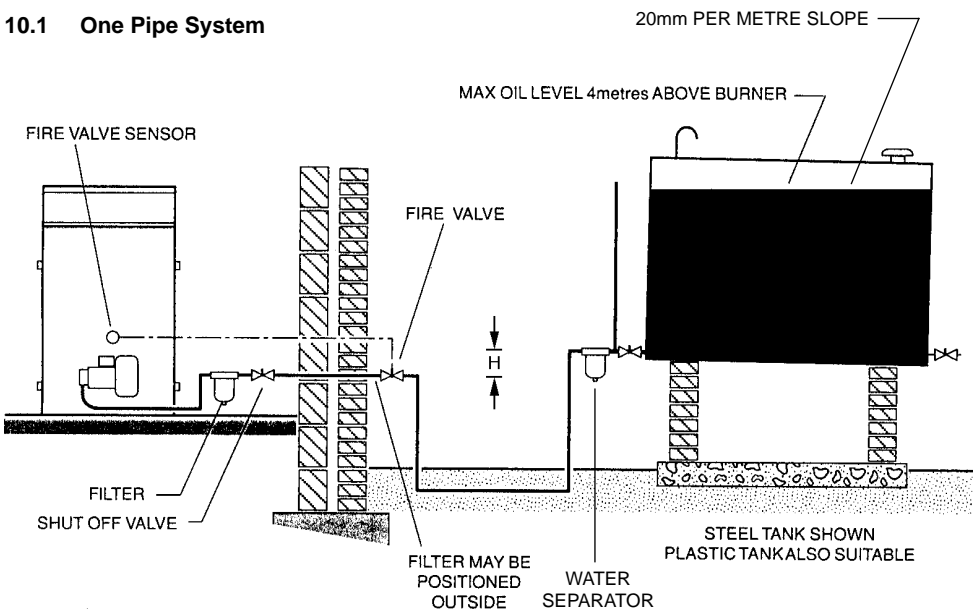

Total Maximum Pipe Length (m)

Head $H_{(m)}$	0.5	1	1.5	2
I.D. 8 mm	10	20	40	60
I.D. 10 mm	20	40	80	100

Note: Plastic oil level gauges may shrink when exposed to kerosene thus allowing the ingress of water. Pump failures due to water contamination are not covered under the warranty.

10.2 Two Pipe System

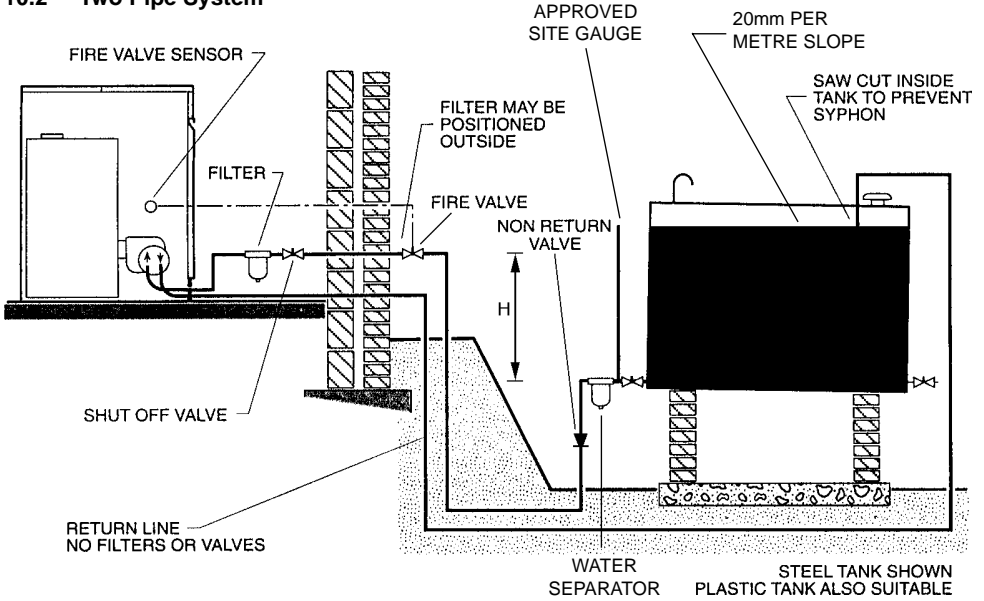

Total Maximum Pipe Length (m)

Lift H _(m)	0.5	0.5	1	1.5	2	3	3.5
I.D. 8 mm	35	30	25	20	15	8	6
I.D. 10 mm	100	100	100	90	70	30	20

10.3 De-aerator System

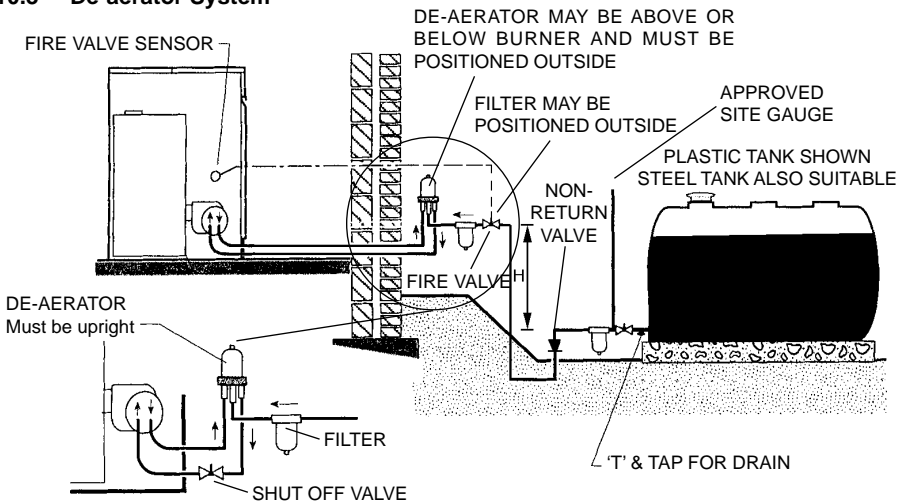

For maximum pipe length and lift contact de-aerator manufacturer.

10.4 One Pipe Lift System

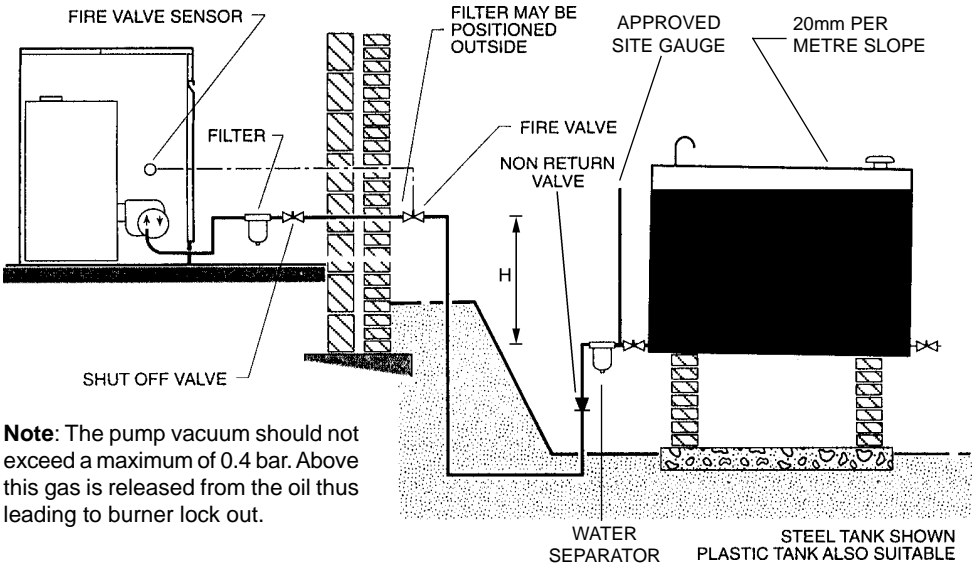

Total Maximum Pipe Length (m)

Lift H _(m)	0.5	0.5	1	1.5	2	3	3.5
ID 8mm	35	30	25	20	15	8	6
ID 10mm	100	100	100	90	70	30	20

11.0 RDB Burner

11.1 Components

The burner is fitted with the correct nozzle and the pressure set. All that is further required before commissioning, is to connect the oil and electricity supply.

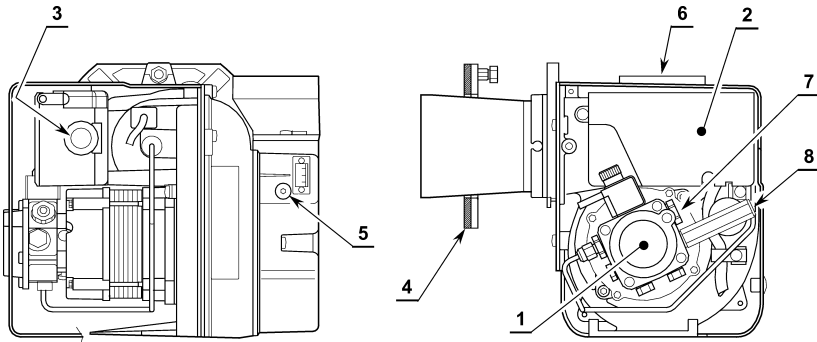

1. Pump
2. Control box
3. Reset button with lock-out lamp
4. Flange with insulating gasket

5. Air damper adjustment screw
6. Air tube connection (B/F) or inlet cover
7. Pump pressure adjustment screw
8. Pressure gauge port

11.2 Oil Pumps

The burner is supplied for use with a one pipe system. For use on a two pipe system, it is necessary to remove the return port plug and fit a small by-pass plug as shown.

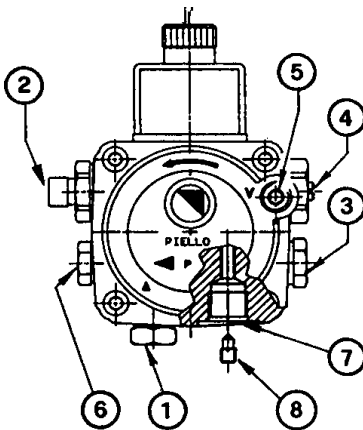

1. Suction port
2. To nozzle
3. Pressure gauge port/air bleed
4. Pump pressure adjustment
5. Vacuum port
6. To hydraulic ram (if fitted)
7. Return port
8. By-pass plug

Note: When the burner locks out due to oil starvation it will be necessary to bleed air from the oil pump whenever the oil supply has been re-established. All call-outs and component failures due to oil starvation are not covered under the warranty and are therefore chargeable.

11.3 Air Damper Adjustment

The setting is purely indicative.

Each installation however, has its own unpredictable working conditions: actual nozzle output; positive or negative pressure in the combustion chamber, the need of excess air, etc.

All these conditions may require a different air-damper setting.

11.4 Electrode Setting

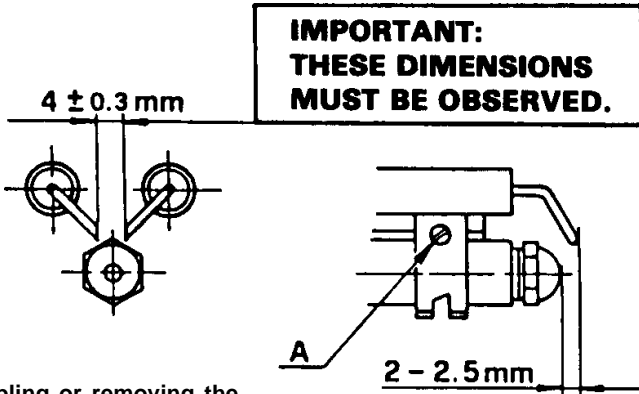

Attention

Before assembling or removing the nozzle, loosen the screw (A) and move the electrodes away from the nozzle.

11.5 Burner Start-up Cycle



12.0 Servicing & Commissioning

12.1 Commissioning

Note: IT IS RECOMMENDED THAT AN OFTEC TRAINED AND REGISTERED TECHNICIAN BE USED.

IT IS THE RESPONSIBILITY OF THE INSTALLER TO ENSURE THAT THE BOILER IS PROPERLY COMMISSIONED. SEE BS 5410. FAILURE TO DO SO MAY INVALIDATE THE WARRANTY.

Combustion tests must be carried out using a combustion analyser.

The pump pressure can be checked by fitting a manifold and a pressure gauge to the oil pump. Before firing ensure that all the baffles are in place as they may have been displaced during transit as shown on page 3 (baffles).

Setting the boiler control to 80°C switch on, ensuring all controls are calling for heat.

Typical burner settings and test data are shown in section 7.1.

Check the smoke reading, CO₂ content and flue gas temperature with the boiler up to temperature. Testing while the boiler is still relatively cold gives inaccurate results and leads to incorrect adjustments being made.

The commissioning details should be included in form OFTEC CD11 and left with the householder.

12.2 Servicing

12.2.1 General Requirements

It is recommended that the appliance is serviced annually by an OFTEC registered service technician in accordance with the recommendations laid out in OFTEC's technical information book 2 – 'Pressure Jet Appliances – Commissioning Requirements for Technicians'.

Additionally when servicing special attention should be paid to the condition of the oil nozzle, flexible oil line, fuel filter and base insulation all of which will need to be replaced on a regular basis.

Note: **Second year or other extended warranties will be invalidated if the appliance is not serviced annually.**

12.2.2 External Wall Mounted Boilers

1. The boiler must be provided with a suitable well drained hard standing area to prevent the formation of pools of water in order to eliminate any risk to the service engineer or end user.
2. The boiler must not be serviced or the panels removed where there is a risk of the ingress of water.

Note: **After servicing ensure that the servicing switch is in the off position otherwise the boiler will run continuously independently of the time clock.**

13.0 Fault Finding

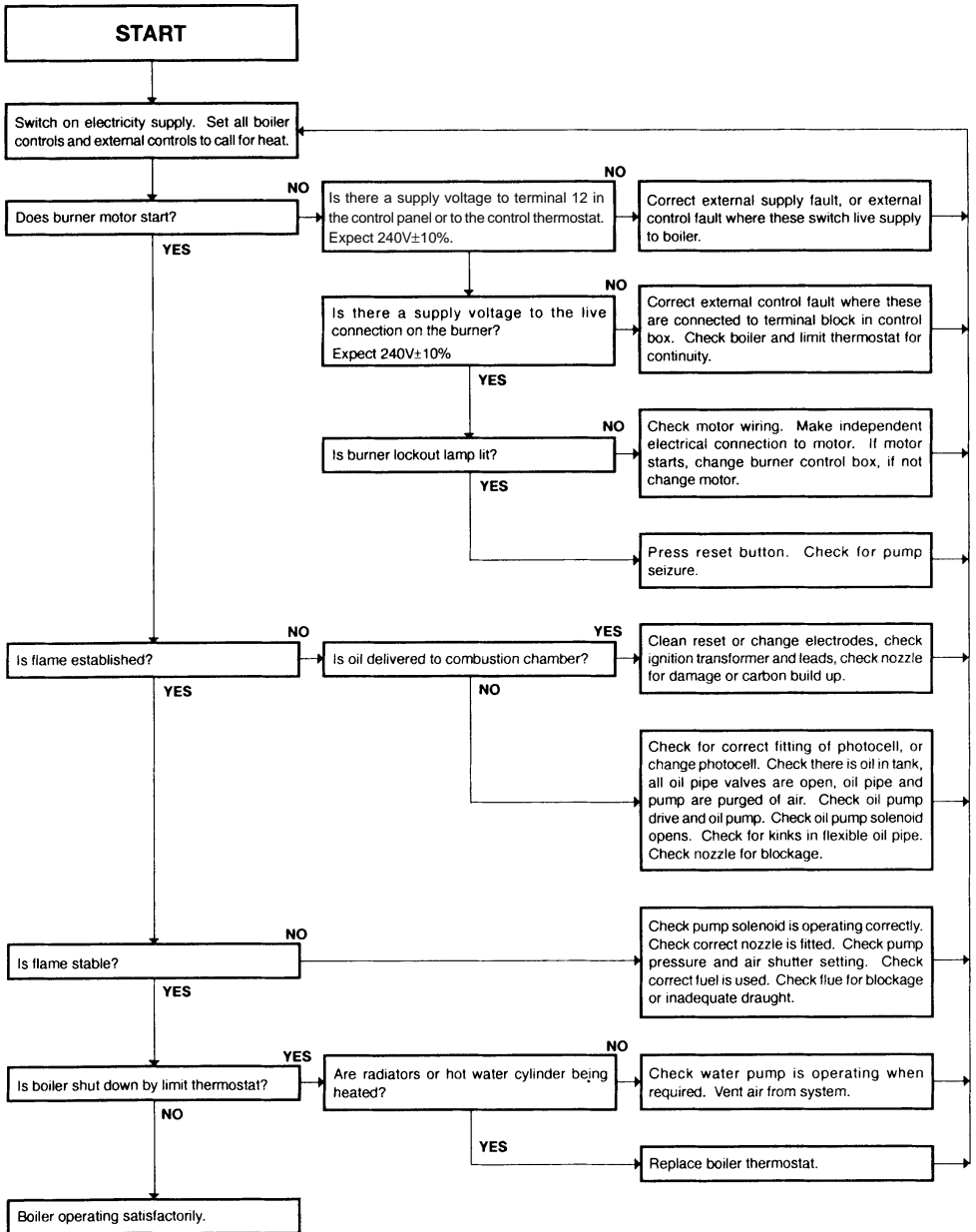

14.0 Spares

14.1 RDB 1 WM Burner Spares

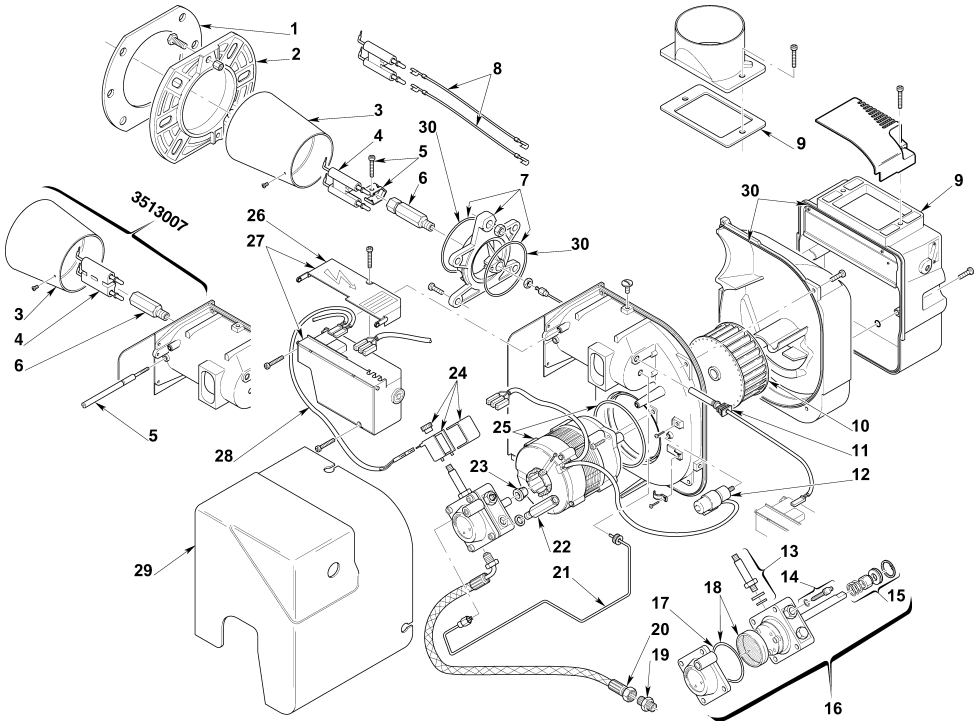

NO	CODE	3513007	DESCRIPTION
1	3005787	•	Gasket
2	3006384	•	Flange
3	3001079	•	Cup-shaped Head
4	3008860	•	Electrode Assembly
5	3008875	•	Screw
6	3008861	•	Nozzle Holder
7	3008862	•	Collar
8	3008794	•	High Voltage Lead
9	3008647	•	Air Damper Assembly
10	3005708	•	Fan
11	3008646	•	PE Cell
12	3007479	•	Capacitor 4 μ F
12	3002837	•	Capacitor 4 $\frac{1}{2}$ μ F
13	3007582	•	Needle Valve
14	3008651	•	Regulator
15	3000439	•	Pump Seal

NO	CODE	3513007	DESCRIPTION
16	3008654	•	Pump
17	3007162	•	'O' Ring
18	3008653	•	Filter 'O' Ring
19	3003602	•	Connector
20	3005720	•	Flexible Oil Line
21	3008644	•	Tube
22	3008876	•	Pressure Gauge
23	3000443	•	Joint
24	3008648	•	Coil – Shell and Knob
25	3008650	•	Motor
25	3002836	•	Motor
26	3008649	•	Protection
27	3008652	•	Control Box 535 RSE/LD
28	3008851	•	Lead Coil
29	3008879	•	Cover
30	3008878	•	Kit Seals

Note: The 4 $\frac{1}{2}$ μ f capacitor is only suitable for use with the 3002836 motor and the 4 μ f capacitor is only suitable for use with the 3008650 motor.

14.2 Short Parts List (Boiler)	Code
Boiler Control Thermostat	2131
Boiler Limit Thermostat	281
Drain Cock	618
Top Baffle	2428
Top Baffle Holder	2448
Baffle	2361
Boiler Cleaning Brush	2470
Door Gasket	2457
Door Insulation	2456
Door Insulation Shield	2440
Vertical Flue Adaptor A	VFA – WM A
Vertical Flue Adaptor B	VFA – WM B
Air Intake Duct	AID
LLF-R Flue Extension	LE 300

When ordering replacement white casing panels it should be noted that due to the painting process there may be some variation in colour.



The Boiler People

Lisburn

Lissue Industrial Estate, Moira Road,
Lisburn, Co Antrim, N Ireland, BT28 2RF
Tel: (028) 9262 1515 Fax: (028) 9262 0869
E-mail: sales@warmflow.co.uk

Manchester

144 Bradford Road,
Manchester, M40 7AS
Tel: (0161) 205 4202
Fax: (0161) 205 4818
E-mail: sales@warmflow.co.uk

Dublin

Balbriggan Industrial Estate,
Dublin
Tel: (01) 841 6158
Fax: (01) 841 6614

**FOR PARTS, SERVICE &
WARRANTY CONTACT**

TEL: (028) 9262 0852

FAX: (028) 9262 2827

E-MAIL: service@warmflow.co.uk

N IRELAND

TEL: (DUBLIN) 8416158

FAX: (DUBLIN) 8416614

REP OF IRELAND

TEL: (0161) 205 4202

FAX: (0161) 205 4818

**ENGLAND,
SCOTLAND & WALES**

**FOR TECHNICAL ASSISTANCE
CONTACT WARMFLOW ON**

TEL: (028) 9262 1515

E-MAIL: technical@warmflow.co.uk

This manual is accurate at the date of printing (E&OE) but will be superseded and should be disregarded if specifications and/or appearances are changed in the interests of continued product improvement.